

J O G KIRCHNER

**INVESTIGATION INTO THE CONTRIBUTION OF GROUND
WATER TO THE SALT LOAD OF THE BREEDE RIVER,
USING NATURAL ISOTOPES AND CHEMICAL TRACERS**

**Report to the
WATER RESEARCH COMMISSION
by the
INSTITUTE FOR GROUNDWATER STUDIES
UNIVERSITY OF THE ORANGE FREE STATE**

WRC Report No 344/1/95

Disclaimer

This report emanates from a project financed by the Water Research Commission (WRC) and is approved for publication. Approval does not signify that the contents necessarily reflects the views and policies of the WRC or the members of the project's steering committee.

Vrywaring

Hierdie verslag spruit voort uit 'n navorsingsprojek wat deur die Waternavorsingskommissie (WNK) gefinansier is en goedgekeur is vir publikasie. Goedkeuring beteken nie noodwendig dat die inhoud die siening en beleid van die WNK of die lede van die projek-loodskomitee weerspieël nie.

J O G KIRCHNER

**INVESTIGATION INTO THE CONTRIBUTION OF
GROUND WATER TO THE SALT LOAD OF THE
BREEDE RIVER, USING NATURAL ISOTOPES
AND CHEMICAL TRACERS**

Final Report to the

WATER RESEARCH COMMISSION

by the

**INSTITUTE FOR GROUNDWATER STUDIES
UNIVERSITY OF THE ORANGE FREE STATE**

**WRC Report No. 344/1/95
ISBN No. 1 86845 142 9**

Obtainable from:

Water Research Commission
P O Box 824
PRETORIA
0001

IGS

**INSTITUTE FOR
GROUND-WATER
STUDIES**

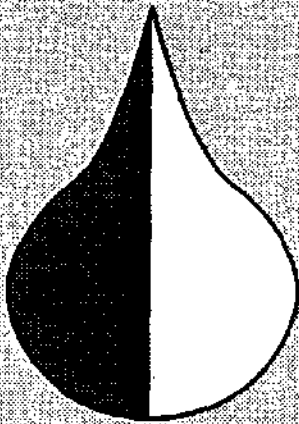

**University of the
Orange Free State
P O Box 339
Bloemfontein 9300
Republic of South
Africa**

**Investigation into the
Contribution of
Ground Water to the
Salt Load of the
Breede River, using
Natural Isotopes and
Chemical Tracers**

by

JURGEN KIRCHNER

April 1994

ABBREVIATIONS and ACRONYMS

ANOVA	Analysis of variance
BRSRP	Breede River Salination Research Program
CCWR	Computing Centre for Water Research
CSIR	Council for Scientific Research
DD22	Example of abbreviation for Site Id No. „3319DD00022”
DWA	Department of Water Affairs and Forestry
EC	Electrical conductivity [mS/m]
G-number	Number of borehole selected by the Directorate of Geohydrology (DWA) or the Geological Survey, e.g. „G 33591”
H5M004	Example of weir number of the DWA
HRI	Hydrological Research Institute
IGS	Institute for Ground-water Studies
MBB	Murray Biesenbach and Badenhorst Inc.
NGDB	National Ground-water Data Base
SMOW	Standard mean ocean water
TMS	Table Mountain Sandstone
Tvl	Transvaal
WRC	Water Research Commission

CONTENTS

List of Figures	iii
List of Tables	v
Acknowledgements	vi
Executive Summary	viii
1. Introduction	1
1.1 The present project	1
1.1.1 Background	2
1.1.2 Objectives of the present study	4
1.1.3 Approach	5
1.1.4 Method	6
1.1.5 Report layout	7
2. Study area	9
2.1 Geography	9
2.2 Geology	10
2.3 Geohydrology	12
2.3.1 Flow regime	12
2.3.2 Surveys	14
2.3.3 Quality	14
2.3.4 Yield	16
2.4 Irrigation in the Breede River	16
3. Salinity research in the Breede River	19
3.1 Review of earlier salinity investigations	19
3.1.1 Surface water	21
3.1.2 Unsaturated zone	23
3.1.3 Irrigation return flow	23
3.1.4 Ground water	26
3.2. The present investigations	31
3.2.1 Sampling network	31
3.2.2 Rainfall	41
3.2.3 Ground water	45
3.2.4 Chemical analyses	50
3.2.5 Isotopes	59
4. Pumping tests	73
4.1 Poesjesnels River	73
4.2 Breede and Vink River areas	74
4.3 Discussion	75
5. Synthesis	77

6. Summary	87
6.1 Objectives	88
6.2 Conclusions	89
6.3 Recommendations	90
7. References	91

Appendix¹

1. List of Sites, Site names and Site types
2. Exploration holes: Borehole logs
3. Exploration holes: Pumping test results
4. Exploration holes: EC- and water-level graphs
5. Chemical analyses : Macro elements
6. Chemical analyses : Micro elements
7. Hydrochemical graphs: Malmesbury Group
8. Hydrochemical graphs: Table Mountain Group
9. Hydrochemical graphs: Bokkeveld Group
10. Hydrochemical graphs: Witteberg Group
11. Hydrochemical graphs: Enon Formation
12. Hydrochemical graphs: Surface water
13. Isotopes analyses: ²H and ¹⁸O
14. One factor ANOVAs for 12 chemical parameters
15. One factor ANOVAs of ²H and ¹⁸O
16. Description of Piper-, Durov-, Schoeller-, SAR- and expanded Durov diagrams

¹ Water-level and EC graphs of the gauging station and dam-release graphs are not included as they are available in the HRI reports. Water-level and EC graphs of the exploration boreholes are not included because the data contain systematic errors.

LIST OF FIGURES

Figure 2.1:	Locality map showing the upper, middle and lower part of the Breede River catchment and the study area	9
Figure 2.2:	Rainfall distribution over the Breede River Valley	10
Figure 2.3:	Upper and Middle part of the Breede River catchment with Measuring Stations and canals (after Kienzle 1990)	11
Figure 2.4:	Generalised cross-section through the Breede River Valley viewing downstream and showing the northerly dip of Table Mountain and Bokkeveld Groups (not to scale)	12
Figure 2.5:	Geological map of the area around Robertson (after Jolly 1990)	13
Figure 2.6:	Main irrigation canals in the middle Breede River catchment	17
Figure 3.1:	Conductivity profile of the Breede River taken in March 1986 (after Howard)	22
Figure 3.2:	Mean daily flow and conductivity measured at H4M017 between May 1990 and April 1991	35
Figure 3.3:	Mean daily flow and conductivity measured at H4M018 between May 1990 and April 1991	36
Figure 3.4:	Mean daily flow and conductivity measured at H4M019 between May 1990 and April 1991	37
Figure 3.5:	Mean daily flow and conductivity measured at H4H011 between May 1990 and April 1991	38
Figure 3.6:	Mean daily flow and conductivity measured at H3H011 between May 1990 and April 1991	39
Figure 3.7:	Mean daily flow and conductivity measured at H5M004 between May 1990 and April 1991	40
Figure 3.8:	Monthly rainfall for three rainfall stations for the period May 1990 to April 1991	41
Figure 3.9:	Rainfall recorded at the Robertson Rainfall Station for the period May 1990 to April 1991	42
Figure 3.10:	Rainfall recorded at the McGregor Rainfall Station for the period May 1990 to April 1991	43
Figure 3.11:	Rainfall recorded at the Worcester Rainfall Station for the period May 1990 to April 1991	44
Figure 3.12:	Mean water level of all monitored G-numbered holes in the Vink- and Robertson area (moving average; a third order polynomial is fitted to the data)	45
Figure 3.13:	Sample of wrongly calibrated data. Mean conductivity determined in all monitored G-numbered holes in the Vink- and Robertson area (moving average)	48

Figure 3.14: Electrical conductivity measurements in standard solutions A, B, C, D and Dx during the period 3 May 1990 to 22 April 1991	49
Figure 3.15: Mean fluoride and barium concentrations of the different sources	56
Figure 3.16: Variations of $\delta^{18}\text{O}$ and $\delta^2\text{H}$ between October 1988 and March 1991 for the two weirs in the Breede River at the upper and lower end of the area of investigation and for the two major tributaries, the Vink- and Kogmanskloof Rivers	66
Figure 3.17: Correlation between mean isotope ratios and the mean conductivity of the Breede River and its tributaries	67
Figure 3.18: Strontium isotope ratios for four river samples, eight irrigation-related samples and seven ground-water samples	70

LIST OF TABLES

Table 2.1:	TDS values for the geological formations found between H4M017 and H5M004 (after Jolly 1990)	15
Table 3.1:	Irrigation return flow data from the report by Lautner (1989)	24
Table 3.2:	Output of the IRRISS model (after Murray, Biesenbach & Badenhorst, 1989).....	25
Table 3.3:	Output of the DISA model for the period June 1985 to April 1986	26
Table 3.4:	Water-level and electrical conductivity statistics of exploration boreholes	47
Table 3.5:	Statistical evaluation of EC control measurements	49
Table 3.6:	Mean temperature and logarithmic mean, number of analyses and standard deviation of chemical variables of all analyses from the different sources	54
Table 3.7:	Mean temperature and logarithmic mean values of chemical variables of all analyses from the different sources	55
Table 3.8:	ANOVA results displaying the number of variables out of a maximum of 13 for which the F-tests between the different sources were significant at the 95% confidence level	58
Table 3.9:	Distribution of $\delta^{18}\text{O}$ and $\delta^2\text{H}$ values and mean electrical conductivities [mS/m] for 12 Malmesbury Group sites	62
Table 3.10:	Distribution of $\delta^{18}\text{O}$ and $\delta^2\text{H}$ values and mean electrical conductivities [mS/m] for 17 Table Mountain Sandstone sites	62
Table 3.11:	Distribution of $\delta^{18}\text{O}$ and $\delta^2\text{H}$ values and mean electrical conductivities [mS/m] for 15 Bokkeveld sites	63
Table 3.12:	Distribution of $\delta^{18}\text{O}$ and $\delta^2\text{H}$ values and mean electrical conductivities [mS/m] for four Witteberg sites	64
Table 3.13:	$\delta^{18}\text{O}$ ratios at different sites along the Breede River and its tributaries (lowest values for the respective sampling periods within the project area are printed in italics)	65
Table 3.14:	$\delta^2\text{H}$ ratios at different sites along the Breede River and its tributaries (lowest values for the respective sampling periods within the project area are printed in italics)	68
Table 3.15:	Strontium concentration and ratios in surface-, irrigation-, return flow- and ground water	70
Table 4.1:	Poesjesnels River Valley: Pumping test results (the first values given for the transmissivity [m^2/d] of this report refer to the pumping test and the second to the recovery test; mean storativities do not include the value for the pumped hole)	73
Table 5.1:	Estimated certainty of values for various water-balance factors	80
Table 5.2:	Flow-, concentration- and Sr-ratio data for 5/6 December 1990	82
Table 5.3:	Mean concentrations of ground-water components for five aquifers as a function of their mean strontium concentrations	84

ACKNOWLEDGEMENTS

The research described in this report resulted from a project funded by the Water Research Commission entitled

"An Investigation into the Contribution of Ground water to the Salt Load of the Breede River, using Natural Isotopes and other Tracers."

The Steering Committee responsible for this project consisted of the following persons:

Mr. H.M. du Plessis	Water Research Commission (Chairman)
Dr. D.B. Bredenkamp	Directorate of Geohydrology, Department of Water Affairs and Forestry
Mr. L. Bruwer	Murray, Biesenbach and Badenhorst
Mr. S. Forster	Directorate of Strategic Planning, Department of Water Affairs and Forestry
Dr. G.J. Greeff	University of Stellenbosch
Dr. A. Görgens	Ninham Shand Inc.
Prof. J.H. Moolman	University of Stellenbosch
Prof. H.J. Potgieter	University of the Orange Free State
Mr. A.G. Reynders	Water Research Commission
Mr. A.S. Talma	CSIR, Ematek
Dr. F. Walraven	Geological Survey
Mr. F.P. Marais	Water Research Commission (Secretary)

The financing of the project by the Water Research Commission and the contributions of the members of the Steering Committee are gratefully acknowledged.

Numerous other people and institutions have contributed significantly towards the completion of this project. The author takes this opportunity to thank all of them. Especially I want to thank:

- Numerous members of the Department of Water Affairs and Forestry, especially Messrs. Marais (for always providing assistance and supplying release data), Luttig (information on the Greater Brandvlei Dam) and Acker (for sample collection) from the Worcester Office; Messrs. Jolly and Bertram (for data supply and discussions) from the Directorate of Geohydrology in Cape Town; Messrs. Forster (for advice and literature) and Van der Merwe (for provision of hydrological data) from Head Office; Mr. Kienzle (for search of chemical, EC- and run-off data stored on the mainframe computer and for discussions) from HRI.
- Dr. Feodor Walraven from the Geological Survey for drawing the Steering Committee's attention to the strontium isotope analyses and carrying out the determinations at no charge.

-
- **Mr. Siep Talma for the deuterium and O-18 analyses (and the special arrangements made to provide the results fast).**
 - **Dr. Greeff (for data, maps and discussions) and Prof. Moolman (for discussion and collection of samples) from the University of Stellenbosch.**
 - **Dr. Görgens from Ninham Shand for DISA data and discussions.**
 - **The staff from Murray, Biesenbach and Badenhorst for sampling, field assistance and discussions.**
 - **The CCWR and the Department of Transport for provision of rainfall data.**
 - **The staff of the Institute for Ground-water Studies, especially Mmes Stevens and Van Schalkwyk for the chemical analyses; Messrs Lukas and Fourie for assistance with data import into and quality control of HydroCom data bases; Mrs Le Roux for draughting and Mmes Botha and Hoffmann for typing and proof-reading.**
 - **Not to be forgotten are the farmers of the study area who frequently went out of their way to assist with survey and sampling.**
-

EXECUTIVE SUMMARY

INTRODUCTION

The Breede River catchment is one of South Africa's primary vine and deciduous fruit growing areas. The greater portion of the irrigated lands, comprising some 45 000 ha, is situated in the middle part of the Breede River Valley between Worcester and Bonnievale.

The Department of Water Affairs and Forestry (DWA) is committed to supply water of a specified quality to the farming community along the Breede River as far downstream as the Bonnievale agricultural area. Salinity levels in the Breede River rose sharply in the 1960's and 1970's. Investigations into the salinisation of the Breede River commenced when increasing amounts of water had to be released from the Greater Brandvlei Dam to freshen the water in the river.

During the past decade, various research projects dealt with different aspects of and factors possibly contributing to the growing salt load in the river. The Water Research Commission (WRC) took a very active role in the co-ordination and funding of these projects which aimed at the better understanding and quantification of the salinisation processes in the Breede River.

Ground water encountered in some of the formations adjacent to the Breede River is brackish or saline. One of the factors influencing the salinity of the water in the Breede River might therefore be a contribution from these formations.

On the side of the DWA, the *Process Hydrology Group* of the Hydrological Research Institute (HRI) took the leading role in the investigations since 1987. This group was assisted by, amongst others, the Directorate of Geohydrology. This Directorate's Cape Town Branch carried out all geohydrological investigations.

The merits of launching a separate investigation to discern between different water sources through natural isotope concentrations were considered by the Institute for Ground-water Studies. If an isotope study could discern between the ground waters in the different geological formations occurring in the Breede River Valley and the various surface-water sources, a quantification of the ground-water contribution to the high salt load of the river seemed possible. After discussions with the WRC and the Directorate of Geohydrology, it was decided that a pilot study be carried out first, to ascertain whether identification of different aquifers contributing to the run-off through *fingerprinting* of ground- and surface waters was possible.

When encouraging results were obtained, the Institute for Ground-water Studies (IGS) proposed a three-year project to the WRC. Before the proposal was accepted, however, the

DWA decided that their *Breede River Salination Research Project* would be terminated in March 1990. Amongst the data collected during that project were electrical conductivity (EC) and water-level measurements. The present project required these data, together with the samples for isotope determination. Because EC- and water-level measurements were also needed for the calibration of a management model of the Breede River resources, the WRC decided to fund (scaled down) data collection for one further year. Consequently, the IGS project had also to be scaled down and shortened.

AIMS

The stated objectives of this project were to:

1. Determine whether part of the salt load in the Breede River is derived from ground water discharging from underlying and adjoining aquifers of the Nama Group, the Cape Supergroup and possibly the Karoo Sequence, by means of an investigation into the spatial distribution and concentration of natural isotopes and chemical tracers in aquifers beneath and along the Breede River.
2. Determine applicability and feasibility of using chemical tracers for pollution- and water balance studies.

The first objectives have been interpreted as aiming at a quantitative rather than a qualitative measure of the ground-water contribution to the salinisation of the Breede River.

APPROACH

To assess the contribution of ground water to the system and especially to the salt balance, two approaches appear possible:

- a) compiling a salt- and water balance from measurements and calculations of the contributions of the various components and
- b) fingerprinting of ground water by means of identifying certain chemical or isotopic properties unique to the ground water in the area that can then be determined and quantified within the river water to obtain a measure of its contribution to the composition (and supposedly also the quantity) of the river water.

Water- and salt-balance calculations require that the main constituents of the system be determined rather accurately. This has proved to be difficult in the present study, partly because of problems in calibrating weirs and partly because of the great number of abstraction points, but also because of the inherent difficulties in determining (representative) rainfall and evapotranspiration figures for larger areas. Quantifying the ground-water component is even more difficult: How can the ground-water recharge, the

flow velocity or the quantity of the return flow be properly assessed? How can a representative salt concentration be ascertained?

Fingerprinting allows the quantitative tracing of a single component in a system if the tracer is unique to this component. If we have components with discernible differences in the concentration of a certain tracer, then qualitative statements about the presence of certain components may be possible. If the number of different tracers with discernible differences and the number of independent measurements exceed the number of the components, it may be possible to obtain (semi-)quantitative answers. Water- and salt-balance calculations may further improve the answers obtained from fingerprinting.

METHODOLOGY

Based on findings of the Pilot project, available funds and time constraints, it was decided that this investigation should be based on chemical analyses from approximately 20 surface-water sites and about 55 ground-water sites sampled four times at quarterly intervals. These sites were chosen from \pm 100 sites sampled during the initial survey because of (i) their representativeness of the various ground-water sources, (ii) their geographical distribution over the area of investigation and (iii) their chemical composition.

Four sampling trips were undertaken during the project. During the first trip, 87 ground-water and 11 surface-water samples were taken for chemical analyses. Based on chemistry, geological formation and areal distribution, the sites were later reduced to 55 ground-water and nine surface-water sites. Samples for $\delta^2\text{H}$ and $\delta^{18}\text{O}$ determinations were first collected from 48 ground-water and 13 surface-water sites. The sampling sites were reduced to 40 and 10 respectively during subsequent sampling trips.

Besides samples and analyses generated as part of this project, the following data were also available: (i) EC- and water-level recorder measurements from six gauging weirs of the DWA, (ii) weekly EC- and water-level measurements of 56 test boreholes, as well as monthly EC measurements at nine additional surface-water sites captured by Murray, Biesenbach & Badenhorst (MBB) as subcontractors of the scaled down WRC funded data collection project. (iii) Rainfall measurements for three stations in the area were obtained from the Computing Centre for Water Research (CCWR).

All the available data as well as historical data from the mainframe computer, the National Ground-water Data Base (NGDB) and from relevant reports were stored in a HydroCom data base for further processing.

Strontium-ratio analyses had not been conceived as a method to provide information about the question of ground-water contribution to river run-off and salinisation and had, therefore, not been budgeted for. Dr. Walraven from the Geological Survey drew the attention of the Steering Committee to this method. After a few samples were taken for

strontium analyses in December 1990, they showed consistent differences in the $^{87}\text{Sr}/^{86}\text{Sr}$ ratios of ground- and river water and in subsequent sampling irrigation and return flow samples were also collected.

Concurrently with sampling analysis and evaluation of the collected data, a review of relevant previous research in the area was undertaken. Some of the earlier data were re-evaluated.

RESULTS AND DISCUSSION

A large number of individual components determine the resulting flow and salt load at the lower end of the research area. The chemical- and stable isotope inputs and outputs are variable in space and time. They are influenced by processes such as rainfall, evapotranspiration and activities of man, for instance, the development of irrigated land, irrigation methods and practices applied or the construction of drains.

ISOTOPE STUDIES

Quantification of the river recharge through ground water by means of ^2H and ^{18}O balance methods transpired to be not feasible because of the following reasons:

- i) From other evidence the ground-water component in the river water seems relatively small. On the other hand, error margins of some of the remaining variables in the system, for instance (a) return flow- and run-off volumes or (b) representative salinities of return flow- and ground water are comparatively large. It would thus not be feasible to calculate ground-water seepage (recharge) to the river with an acceptable degree of confidence.
- ii) Evapotranspiration influences the ^2H and ^{18}O isotope ratios of the water used for irrigation. However, the degree varies to which the ratio is affected, depending on the relative rate of evapotranspiration versus leaching. A representative isotope ratio of the return flow can thus not be established with the necessary accuracy. When flows are low in the Breede River, i.e., during the summer months, return flow constitutes a large proportion of the total flow at the lower end of the study area. As the isotope ratio of one major flow component is not known with sufficient accuracy, ^2H and ^{18}O balancing cannot yield quantitative answers.

Strontium isotope ratios carry the signature of the geological formations with which they were in contact. They are not influenced by the factors that change the ^2H and ^{18}O isotope ratios.

Consequently strontium-ratio analyses proved to be a good indicator of the origin of the water found in the system: Ground water has a noticeable higher ratio than surface water and processes at the surface and in the alluvium do not seem not to alter the ratio found in the applied irrigation water.

By using strontium isotope ratio analyses, it was possible to quantify the ground-water contribution to the run-off in the Breede River. A relatively big difference was found between the strontium isotope ratios of river and ground-water samples, while the ratios for irrigation water and agricultural drains, were practically the same. A small increase between the strontium ratios in river water from the top end of the scheme (at Le Chasseur) and those from the bottom (at Secunda) would be explained by ground water contributing approximately 6,7% of the total strontium flowing past Secunda (as calculated for the sampling period in December 1990). Because the strontium concentration found in ground water from different geological formations varies considerably, the ground-water contribution to the total flow at Secunda could vary between 3% (for Bokkeveld shale) and 34% (for Table Mountain Sandstone) of the flow at the lowermost weir at Secunda (where the flow was $\approx 58000 \text{ m}^3/\text{d}$).

From these calculations it can thus be concluded that either:

- i) a significant proportion ($\approx 80\,000 \text{ m}^3/\text{d}$) of the water that leaves the system (i.e. flow in the Breede River at the Secunda and the canal exports of the Angora and Zanddrift canals) is of Table Mountain Sandstone (TMS) origin which, because of its low salt (17 mg/l) content, would have a freshening effect on the water in the Breede River, or
- ii) a very small percentage ($\approx 6\,500 \text{ m}^3/\text{d}$) of the flow in the Breede River at Secunda and the canal exports is derived mainly from high salinity (1 996 mg/l) Bokkeveld water.

Either way, it can be concluded that ground water cannot be a significant source for the salt load of the Breede River.

GROUND-WATER FLOW RATE

Pumping tests carried out previously by Greeff in the Poesjesnels River Valley and by Jolly near Robertson were re-assessed in order to obtain an independent evaluation of the quantity of in-flowing ground water. When the results of these evaluations are extrapolated for the whole length of the Breede River between Le Chasseur and Secunda, the likely ground-water contribution is in the order of $\approx 4000 \text{ m}^3/\text{d}$, excluding inflow from deep-seated faults or fracture zones. This figure agrees favourably with the $6\,500 \text{ m}^3/\text{d}$ calculated above for inflow from Bokkeveld shale.

For the calculation of the ground-water flow rate, use was made of weekly water-level measurements in test holes drilled by the DWA along the Breede and Vink Rivers. These

water levels showed hardly any fluctuations. A rather constant flow rate throughout the year could therefore be assumed.

CHEMICAL DIFFERENCES BETWEEN WATERS FROM DIFFERENT SOURCES

Over 600 ground-water and surface-water samples were analysed for 23 different variables. Analyses of variance (ANOVA) showed that 13 of these variables yielded F-test values which were significantly different from each other at a 95% confidence level. The few Enon and Witteberg samples prohibited that Enon water could be discerned from Witteberg and TMS, and Witteberg from Malmesbury. In all other cases, between two and 12 different variables allow to differentiate qualitatively between the different ground waters. Except for Enon and TMS, all ground water samples were also statistically different from the Breede River water.

Weekly EC measurements in the test holes and at a number of surface water sites were not usable because of instrument drift, insufficient calibration and possibly incorrect sampling procedures.

IRRIGATION RETURN FLOW

Maximum irrigation and consequently the highest volumes of irrigation return flow occur near the lower end of the study area; this is also the stretch of the Breede River where salinisation is increasing most rapidly. From the geological disposition, one would expect that the effect of in-flowing salty ground water should be more evenly spread. This strengthens the perception that ground water of a high salt content does not enter the Breede River in appreciable amounts.

EVALUATION

Both objectives have been met. It was determined that ground water inflow plays only a minor role in the salinisation of the Breede River.

Unique chemical tracers for the individual water balance components have not been found. Unless considerable simplification is tolerated, balancing by means of chemical and/or ^2H - and ^{18}O -ratios can also not yield answers with the required accuracy.

Independent from the strontium study, a relatively low ground-water flow rate of approximately $4\,000\text{ m}^3/\text{d}$ has been obtained from re-evaluated pumping tests.

Increased flows along major faults or fractures of relatively fresh ground water from the TMS seem, however, possible, although ^2H - and ^{18}O -ratios do not indicate this. Salt

dissolution along preferential pathways in the Bokkeveld is the only explanation why strong boreholes in this formation yield better water than low-yielding and so-called dry holes.

In general, ground waters occurring in the area are significantly different from one another and can be classified on the basis of their chemical composition. Likewise, the different aquifers exhibit typical deuterium and oxygen-18 characteristics which allow their qualitative distinction from each other and from surface waters.

Much effort went into improving weak data, although the envisaged mass balance calculation did not yield the expected results. Running this investigation concurrently with the Breede River Salination Research Program (BRSRP) of the HRI would have provided more data and better data control. A laudation of the Water Affairs BRSRP team who ran the program for three years, appears well suited. Good data control during data capturing is essential and their personnel proved to be qualified, experienced and dedicated.

RECOMMENDATIONS

1. The mean value of the strontium ratios from seven ground-water samples is considered to be representative. The calculated contribution of ground water to the flow in the Breede River is, however, also based on a comparatively small difference in the strontium ratio of two samples, one each from two gauging weirs in the Breede River. It seems advisable to collect further samples for strontium-ratio analyses at these two weirs during low-flow conditions. A better populated data base will assure a more representative figure for the calculated ground-water contribution.

A few more samples from inflow-, outflow- and return flow should be taken for strontium ratio determination during the dry season. This will ensure a more representative figure for the calculated ground-water contribution.

2. For the investigation of areas with similar problems, the strontium isotope ratio method seems superior to other approaches and should be further tested for its applicability.
3. Where water conductivity- and chemical quality surveys are carried out, parameter values should be determined from representative samples taken, e.g., after sufficiently long pumping of holes rather than from samples bailed, because stratification of water occurs in many boreholes.

1. INTRODUCTION

Following the Vaal, Orange and Olifants River (Tvl), the Breede River catchment is the fourth largest irrigation area in South Africa¹. It is one of South Africa's primary vine and deciduous fruit growing areas. The greater portion of the irrigated lands, comprising some 45 000 ha, is situated in the middle part of the Breede River Valley between Worcester and Bonnievale.

Irrigation in the valley began in the 18th century. As the valley lies in the winter rainfall region, most of the run-off occurs during the winter months, while water is mainly needed during the irrigation season between October and April. Winter run-off is therefore stored in dams. The Brandvlei Dam was built in 1922 to supply irrigation water for the middle part of the Breede River Valley. The dam had a capacity of $45,8 \cdot 10^6 \text{ m}^3$. In 1949, it was enlarged and could store almost twice that amount. A comparatively small dam of unknown capacity, later called the Kwaggaskloof Dam, was bought in 1972 from a certain David van der Merwe.

When the demand increased, the walls of the Brandvlei and Kwaggaskloof Dams were raised in 1983 to combine the two dams into the Greater Brandvlei Dam with full supply-level capacities of $303,8 \cdot 10^6 \text{ m}^3$ and $170,9 \cdot 10^6 \text{ m}^3$ respectively, i.e., a total of $474,7 \cdot 10^6 \text{ m}^3$. Apart from local run-off from the mountains surrounding the Greater Brandvlei Dam, water can be pumped from the Breede River into the dam at a rate of $5 \text{ m}^3/\text{s}$.

The Department of Water Affairs and Forestry (DWA) is committed to supply water of a specified quality to the farming community along the Breede River as far downstream as the Bonnievale agricultural area. The lowermost users are served by the Zanddrift Canal. Salinity levels in the Breede River rose sharply in the 1960's and 1970's (Greeff, 1990, p.2), particularly upstream of the Angora and Zanddrift Canals. Investigations into the salinisation of the Breede River began when increasing amounts of water had to be released from the Greater Brandvlei Dam to freshen the water in the river.

During the past decade, various research projects dealt with different aspects of and factors possibly contributing to the growing salt load in the river. The Water Research Commission (WRC) took a very active role in the co-ordination and funding of these projects which aimed at the better understanding and quantification of the salinisation processes in the Breede River.

¹ Approximately 100 000 ha are under irrigation in the Breede River Valley.

1.1 THE PRESENT PROJECT

Ground water encountered in some of the formations adjacent to the Breede River upstream of the Zanddrift and the Angora Canal off-takes is brackish or saline. One of the factors influencing the salinity of the water in the Breede River might therefore be a contribution from these formations.

On the side of the Department of Water Affairs and Forestry, the *Process Hydrology Group* of the Hydrological Research Institute (HRI) took the leading role in the investigations since 1987. This group was assisted by, amongst others, the Directorate of Geohydrology. The Directorate's Cape Town Branch carried out all geohydrological investigations.

The possibility of launching a separate investigation to discern between different water sources through natural isotope concentrations was soon considered by the Institute for Ground-water Studies. If an isotope study could discern between the ground waters in the different geological formations occurring in the Breede River Valley and the various surface-water sources, a quantification of the ground-water contribution to the high salt load of the river seemed possible. After discussions with the Water Research Commission and the Directorate of Geohydrology, it was decided that a pilot study be carried out first, to ascertain whether identification of different aquifers contributing to the run-off through *fingerprinting* of ground- and surface waters was possible.

When encouraging results were obtained, IGS proposed a three-year project to the Water Research Commission in May 1989. Before the proposal was accepted, however, the Department of Water Affairs and Forestry decided that their involvement in the investigations and funding of the Breede River research would cease in March 1990¹. Amongst the data collected by the DWA were measurements of the electrical conductivity (EC) and of water levels in test boreholes. The project proposed by IGS required these data, together with the samples for isotope determination. Because EC- and water-level measurements were also needed for the calibration of a management model of the Breede River resources, the WRC decided to fund scaled down data collection for one further year. Consequently, the original IGS project proposal had also to be reduced and shortened to one year.

¹ This decision had been taken in the light of efforts to reduce government spending. The fact that the development of a model for the management of the Breede River was well under way and personnel changes within the HRI may also have affected that decision.

1.1.1 BACKGROUND

The hydrological system of the middle stretches of the Breede River which was the target area of many studies is highly complex. The water balance of the system is influenced by the following:

GAINS OF THE SYSTEM

- a) flow in the Breede River above Le Chasseur which comprises run-off from the upper reaches of the river, releases from the Greater Brandvlei Dam, irrigation return-flow, rainfall and a ground-water component;
- b) subsurface inflow of ground water;
- c) inflow of the tributaries between Le Chasseur and Secunda (made up from the same components as listed under a) above);
- d) Le Chasseur- and Goree Canal imports used for irrigation, including canal seepage and rejects;
- e) ground-water recharge and
- f) precipitation onto the Breede River itself, including overland flow.

LOSSES OF THE SYSTEM

- a) surface-water outflow at Secunda;
- b) subsurface outflow of ground water;
- c) Zanddrift- and Angora Canal exports and
- d) evapotranspiration from the surface, riverine vegetation and from irrigated lands.

STORAGE CHANGES OF THE SYSTEM

- a) Because the system does not react instantaneously and steady-state conditions do not exist, change in the (surface- and subsurface-) storage must also be accounted for.

RECIRCULATION WITHIN THE SYSTEM

Recirculation of water occurs within the area surrounding the river. This consists of:

- a) diversion of river water into canals and direct pumping from the river for irrigation. Some of this water returns to the river as canal- and dam seepage and irrigation return flow;
- b) ground-water abstraction for irrigation also leads to (additional) irrigation return flow.

Factors contributing to an increase in the salt concentration of the river water can be summarised as follows:

- i) Concentration through evaporation of surface water.
- ii) Dissolution of salts in weathered soils by rain water.
- iii) Saline ground water flowing into the Breede River or its tributaries.
- iv) Return flow from irrigated areas or from leaking canals and dams (concentration through evapotranspiration, increased in areas where water levels have risen to near the surface; dissolution of salts in the soil; sodium salts released after gypsum application; over-fertilisation).
- v) Point-source pollution.

Factors i to iii are (mainly) natural processes and iv and v are the result of the agricultural and industrial activities respectively.

Previous investigations dealt with the determination of the size of the problem and the quantification of the effects of the various contributing elements [amongst others by Flügel¹, Kienzle, Howard, Volkmann and Lautner from the HRI; Greeff and Moolman from the University of Stellenbosch; Bertram and Jolly from the DWA as well as Murray, Biesenbach and Badenhorst Inc. (MBB)] and also the alleviation of the problem, including management strategies [cf. Forster from the DWA and Görgens from Ninham Shand].

The different aspects researched which contributed to clarify the importance of the individual processes regarding the salinisation of the Breede River were: Efficiency of the canal system, Isotopic composition of the water, Irrigation practices, Irrigation efficiency, Salinity of irrigation return flow, Processes in the soil and Soil salinisation, Salt occurrence in weathered soils, Ground-water quality, Ground-water levels and Aquifer parameters.

While trend analyses have been applied to assess the seriousness of the salinisation threat, water- and salt-balance calculations helped to identify the importance of the individual components. The use of hydrosalinity modelling techniques allowed a better assessment and provided a tool to manage the salt concentrations in the Breede River.

However, the ground-water contributions to the system are relatively small, as will be shown later. It is therefore difficult to calculate its contribution in an equation where major components such as the total in- and outflow and evapotranspiration (natural and induced by irrigation) cannot be assessed with the necessary accuracy.

1.1.2 OBJECTIVES OF PRESENT STUDY

Against this background the present study was undertaken with the following objectives:

- Determine whether part of the salt load in the Breede River is derived from ground water discharging from underlying and adjoining aquifers of the Nama Group, the Cape

¹ See Chapter 8 for detailed references to authors mentioned here.

Supergroup and possibly the Karoo Sequence, by means of an investigation into the spatial distribution and concentration of natural isotopes and chemical tracers in aquifers beneath and along the Breede River.

- Determine applicability and feasibility of using chemical tracers for pollution- and water-balance studies.

1.1.3 APPROACH

To assess the contribution of ground water to the system and especially to the salt balance, two approaches appear possible:

- a) compiling a salt- and water balance from measurements and calculations of the contributions of the various components and
- b) fingerprinting of ground water by means of identifying certain chemical or isotopic properties unique to the ground water in the area that can then be determined and quantified within the river water to obtain a measure of its contribution to the composition (and supposedly also the quantity) of the river water.

Water- and salt-balance calculations require that the main constituents of the system be determined rather accurately. This has proved to be difficult in the present study, partly because of problems in calibrating weirs and partly because of the great number of abstraction points, but also because of the inherent difficulties in determining (representative) rainfall and evapotranspiration figures for larger areas. Quantifying the ground-water component is even more difficult: How can the ground-water recharge, the flow velocity or the quantity of the return flow be properly assessed? How can a representative salt concentration be ascertained?

Fingerprinting allows the quantitative tracing of a single component in a system if the tracer is unique to this component. If we have components with discernible differences in the concentration of a certain tracer, then qualitative statements about the presence of certain components may be possible. If the number of different tracers with discernible differences and the number of independent measurements exceed the number of the components, it may be possible to obtain (semi-)quantitative answers. Water- and salt-balance calculations may further improve the answers obtained from fingerprinting.

Based on findings of the Pilot project, available funds and time constraints, it was decided that this investigation should be based on chemical analyses from approximately 20 surface-water sites and about 55 ground-water sites sampled four times at quarterly intervals. These sites were chosen from \pm 100 sites sampled during the initial survey because of (i) their representativeness of the various ground-water sources, (ii) their geographical distribution over the area of investigation and (iii) their chemical composition. Regular deuterium and

oxygen-18 analyses were carried out on samples from approximately 40 ground-water and 6 surface-water sites. EC- and water levels in exploration boreholes and at a network of surface-water measuring points were to be measured regularly by a third party and made available for this investigation.

Towards the end of the data acquisition phase, about 20 water samples from different sources were analysed for strontium isotopes to evaluate the potential of this technique to be used as unique tracer in ground- and surface-water studies.

1.1.4 METHOD

Because of budget constraints, not all boreholes, fountains, etc., in the study area could be sampled. Guided by areal distribution, accessibility and aquifer, approximately 100 ground-water sites were selected for initial sampling. In addition, surface-water samples from selected locations in the Breede River and its tributaries were collected during the initial visit in the beginning of June 1990. Furthermore, ± 50 samples were collected by Murray, Biesenbach and Badenhorst (MBB) from the test holes in the Vink River and Robertson areas as part of their routine sampling for the DISA hydrosalinity modelling project. All these samples were chemically analysed for a wide range of variables. For a selected number of these samples, ^2H and ^{18}O were also determined.

Thereafter, approximately 50 borehole samples representative of the four deeper-lying aquifers¹ in the area and ± 15 surface-water samples were collected for chemical analysis at quarterly intervals between early September 1990 and March 1991. Regular deuterium and ^{18}O analyses were carried out on a reduced number of these samples. In addition, supervision of the hourly monitoring of the run-off in the Breede River and its tributaries, as well as weekly water-level- and EC measurements, was taken care of by MBB.

Following a proposal of the Steering Committee, a selected number of ground- and surface-water samples were collected towards the end of the project and analysed for their $^{87}\text{Sr}/^{86}\text{Sr}$ -ratios.

A conductivity profile in the Breede River between Le Chasseur and Secunda aiming at the detection of in-flowing water of different quality was done by Howard in 1986. In March 1991, an only partially successful attempt was made to repeat this exercise at low water conditions to detect subsurface inflow.

As far as available, all relevant data already generated in Breede River salinisation research projects were collected. These and the new data were entered into HydroCom and processed.

¹ Malmesbury-, Table Mountain-, Bokkeveld- and Witteberg Group.

Re-evaluation of pumping tests carried out by Greeff (1990) and Jolly (1990) has been done. Some other previously published data were interpreted anew.

1.1.5 REPORT LAYOUT

The report is organised in the following way: the geographical position of the study area and its geology and geohydrology are described in Chapter 2. This is followed by an overview of the development of the irrigation in the Breede River Valley and today's problems facing the scheme.

Previous research in the valley regarding geohydrology and hydrochemistry is outlined in Chapter 3.1. In Chapter 3.2, the sampling network and the data available for this report are discussed first. The results of chemical analyses are described next. This is followed by an analysis of the stable isotope results and the findings of strontium ratio investigations. Analyses of variance regarding the significance of the chemical and isotope data conclude the chapter.

A re-evaluation of previously conducted pumping tests is done and ground-water discharge into the Breede River is estimated in Chapter 4.

In Chapter 5, the author has tried to synthesise the results of this study and the findings of previous ground-water research in the valley. A quantification of the recharge of the Breede River by ground water and the salt contribution of ground water to the flow is attempted.

Chapter 6 evaluates and summarises the results of this project and makes recommendations for further research.

Most of the data and tables are contained in an Appendix. Nearly all data are stored on a HydroCom data base.

2. STUDY AREA

2.1 GEOGRAPHY

The Breede River originates in the Ceres Valley, approximately 100 km NW of Cape Town, and flows in a south-easterly direction where it reaches the Indian Ocean after 320 km at Witsand/St. Sebastians Bay (see Figure 2.1). The catchment covers an area of 12 596 km² and the mean annual run-off is 1760·10⁶ m³. The area is situated in the central part of the Cape Fold Belt and falls within the winter rainfall area.

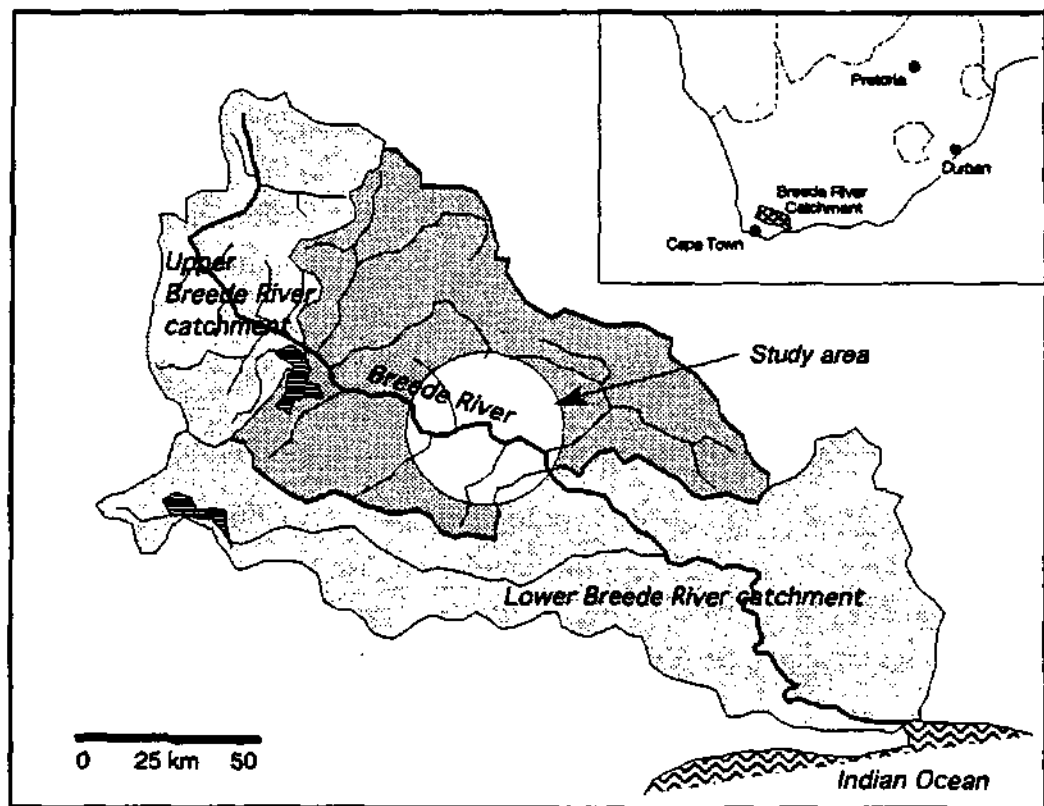

Figure 2.1: Locality map of the upper, middle and lower Breede River catchment and the study area.

The middle part of the valley lies between the Riviersonderend Mountains in the South and the Langeberg Mountains in the North. Both ranges reach maximum elevations of nearly 1700 m with a maximum mean annual precipitation of 1600 to 2000 mm (Beuster *et al.*, 1990; see Fig. 2.2). The valley in lee of the Riviersonderend Mountains is semi-arid. The mean annual rainfall measured in Robertson between 1966 and 1986 was 273 mm, while the A-pan evaporation reached about 1790 mm per year.

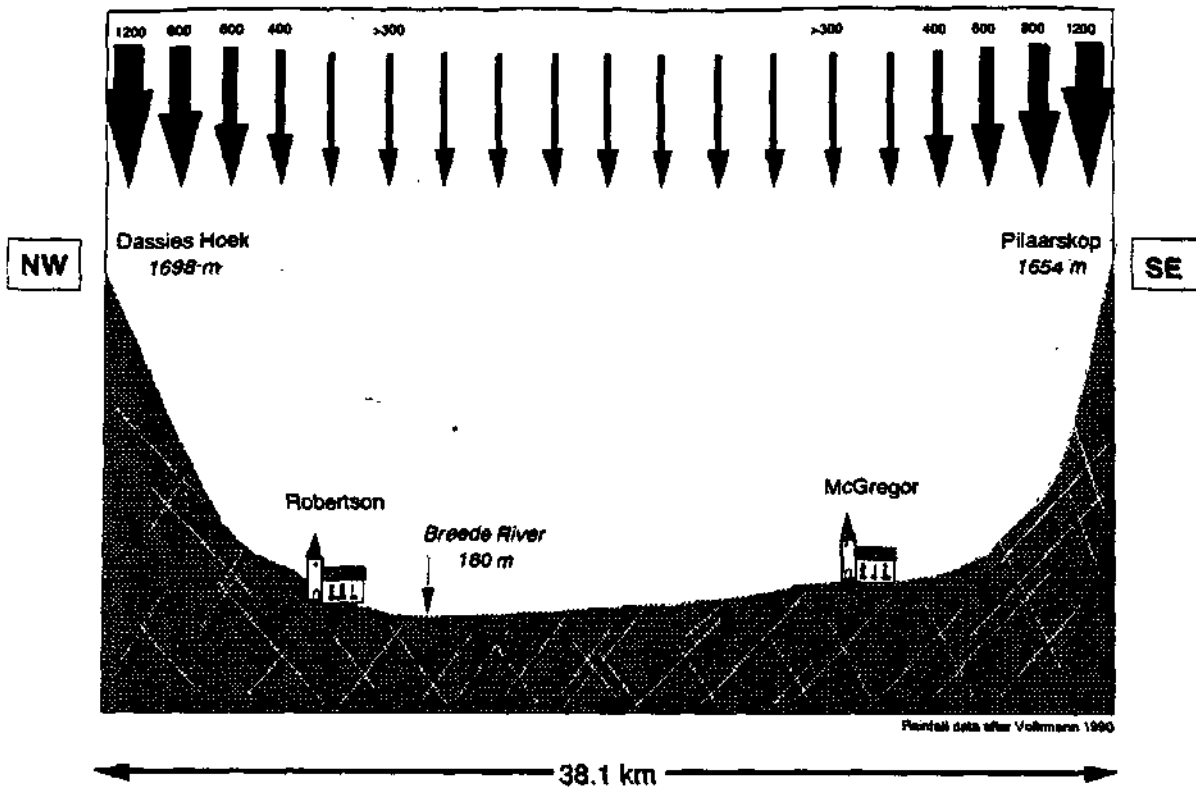

Figure 2.2: Rainfall distribution over the Breede River Valley (vertical scale 10 times horizontal scale).

The study area is situated in the middle part of the Breede River Valley and comprises that part of the valley which lies between the Le Chasseur Gauging Weir about halfway between the Greater Brandvlei Dam and Robertson and the Gauging Station H5M004 at Secunda, approximately three kilometres south of the Kogmanskloof River Mouth, i.e., about 16 km downstream of Robertson. The bounding mountain ranges are about 30 km apart from each other and the area in between is occupied by the Breede River and several tributaries: the Poesjesnels and the Keisers River Valleys on the southern right side as well as Vink-, Klaas Voogds-, Kogmanskloof- and a few smaller rivers on the northern side (see Fig. 2.3).

The upper and middle parts of the Breede River Valley are regions of high agricultural productivity. Viticulture is the main agricultural activity, with growing of fruits and vegetables taking second and third place.

2.2 GEOLOGY

Both mountain ranges on either side of the valley consist of formations of the Table Mountain Group.

Figure 2.3: Upper and Middle part of the Breede River catchment with Measuring Stations and canals (after Kienzle, 1990).

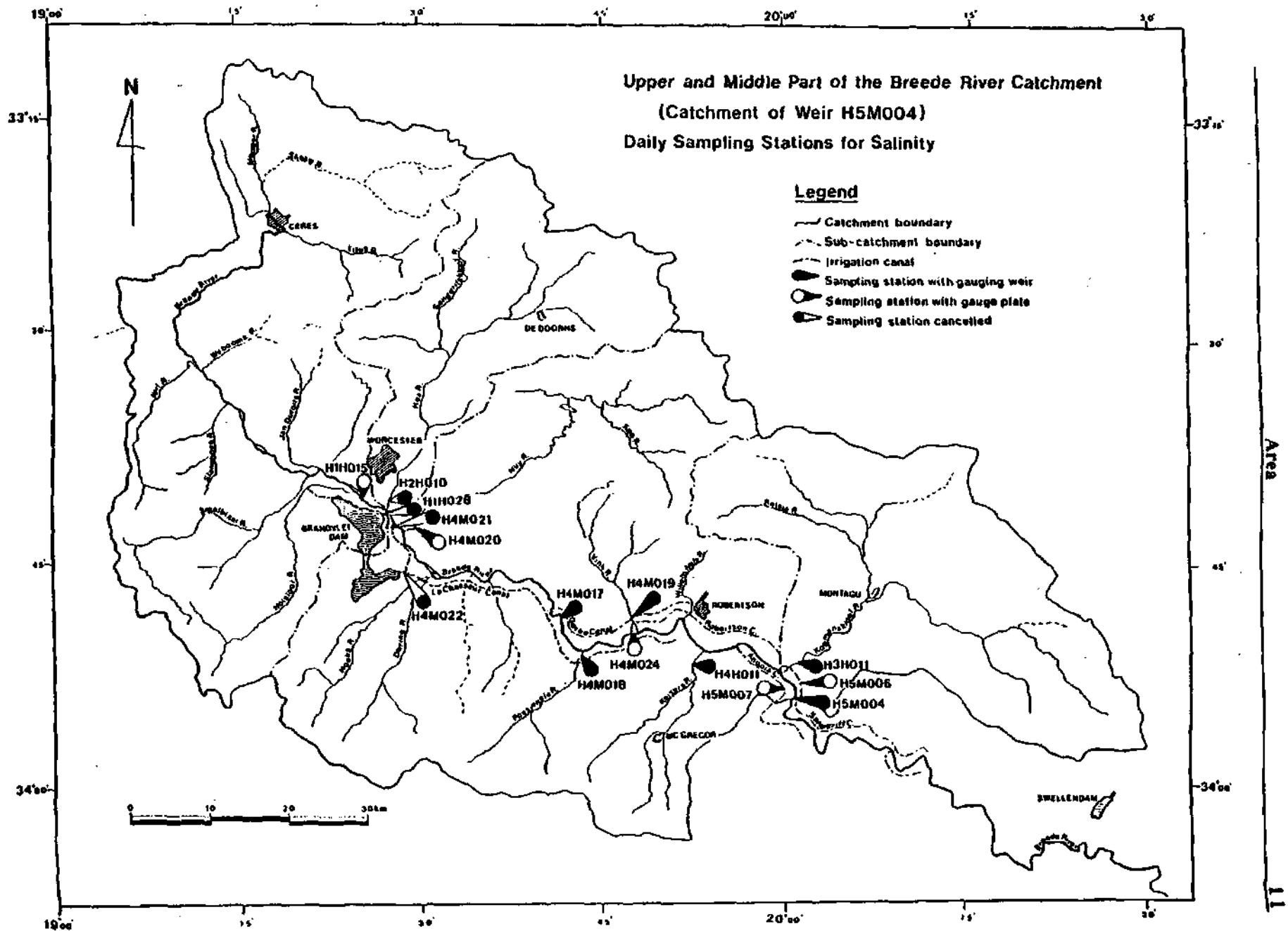

Generalising the geology, the dip of the formations is predominantly in a northerly direction (Fig. 2.4). Formations of the younger Bokkeveld and Witteberg Groups are therefore found south of the river, i.e., north of the Riviersonderend Range. Rocks of the Karoo Sequence (Dwyka and Ecca Formations) occur below the Kwaggaskloof Dam in the north-western part of the area and in a few patches south of the Worcester Fault. North of the fault, the Malmesbury Group is found, underlying the Table Mountain Group of the Langeberg Mountains. The Enon Formation occurs east of Robertson, between the Breede River and the Worcester Fault. Alluvial sediments are found in the plain of the Breede River and alongside its tributaries.

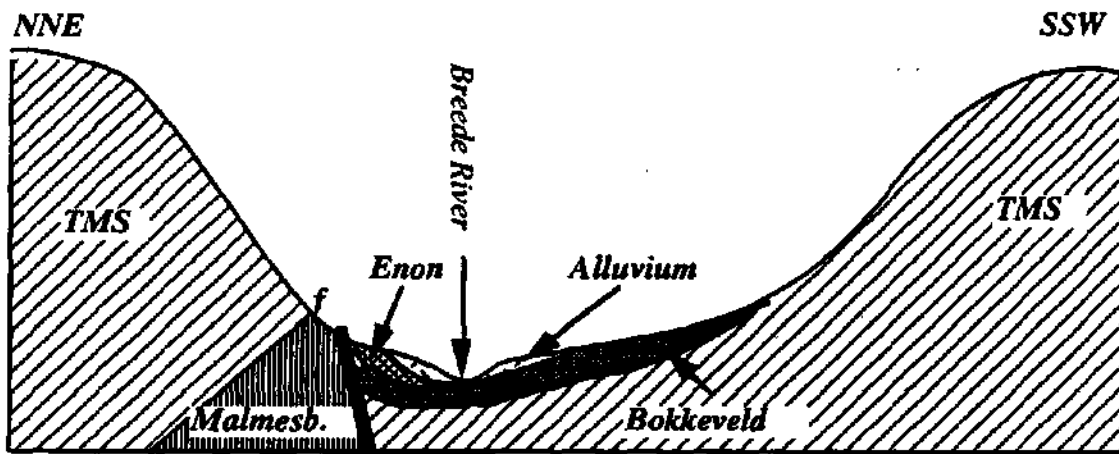

Figure 2.4: Generalised cross-section through the Breede River Valley viewing downstream and showing the northerly dip of Table Mountain and Bokkeveld Groups (not to scale).

The area has been mapped by the Geological Survey. A recent map has, however, not yet been published. The approximate distribution of the geological formations is shown in Figure 2.4 (after Jolly, 1990).

2.3 GEOHYDROLOGY

2.3.1 FLOW REGIME

Ground water is encountered in rocks of all geological ages. With the exception of the alluvium, all aquifers are secondary aquifers, i.e., the ground water moves primarily along faults, fractures and joints. Considerable quantities of water may, however, be stored in the matrix. The main recharge occurs in the mountainous areas on either side the Breede River Valley where the rainfall is high (cf. Figure 2.2). From the mountains, the ground-water flow is directed towards the tributaries and eventually towards the Breede River itself (cf. Fig. 9 in Greeff, 1990 and Figs. 6 and 7 in Jolly, 1990).

GEOLOGY OF THE BREEDE RIVER VALLEY











-  Alluvium
 -  Enon Conglomerate
 -  Ecca Group
 -  Dwyka Formation
 -  Witteberg Group
 -  Bokkeveld Group
 -  Table Mountain Group
 -  Foliated Biotite-Eucrite
 -  Coarse-grained Granite
 -  Malmesbury Group
 -  Fault
- } Karoo Supergroup
- } Cape Supergroup

Figure 2.5: Geological map of the area around Robertson (after Jolly, 1990).



2.3.2 SURVEYS

Various geohydrological aspects have been studied during the past two decades. Our knowledge of the geohydrology is based to a large degree on the investigations by:

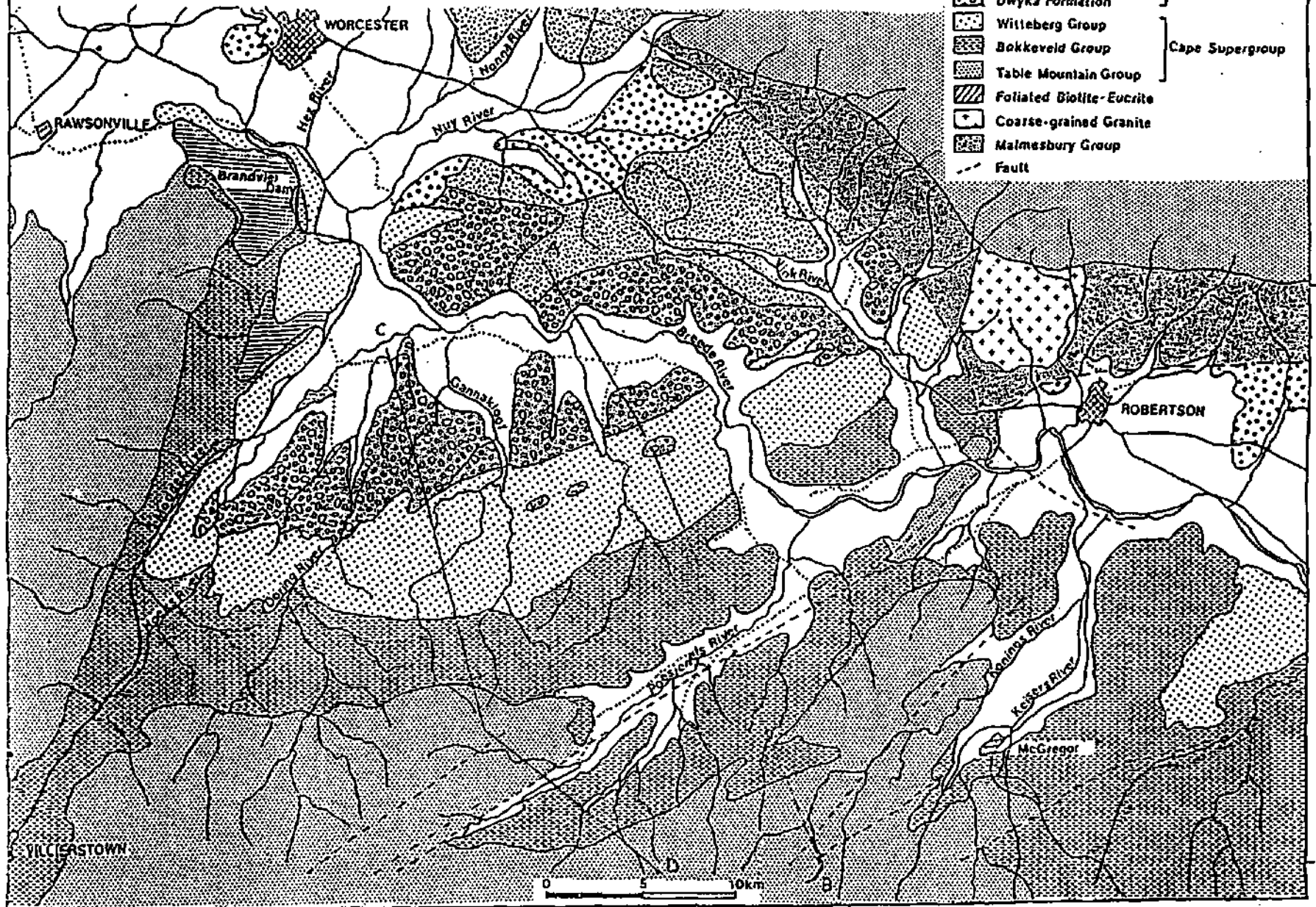
- (i) Wittingham (1976), who mapped the geology of the Worcester District, i.e., upstream of the Vink River. A table with borehole and water consumption data is included in his report.
- (ii) Greeff concentrated on the geological formations and the quality of the water encountered in the different aquifers between the Brandvlei Dam and Robertson (Greeff, 1978) and described tritium concentrations in ground water along a tributary of the Breede River, the Poesjesnells River Valley (Greeff, 1979).
- (iii) Bertram (1989) carried out a hydrocensus between the Greater Brandvlei Dam and the Zanddrift weir to gather information on the occurrence, quality, availability and use of ground water. The main aim was to investigate the correlation between quality, yield and the different geological formations. One-hundred and fifty-five holes used for irrigation were included in the survey. He determined that a total of $10,8 \cdot 10^6 \text{ m}^3$ of ground water was abstracted annually from the area. The average electrical conductivity of the ground water being used was 70 mS/m. However, there was a significant difference in the quality of the water from different geological formations. No significant correlation between yield and geological formation was found.
- (iv) Jolly (1990) collated the information of the previous surveys and added water-level and chemical results from the drilling program carried out by the Department of Water Affairs and Forestry during the 1988/89.

2.3.3 QUALITY

Table Mountain Sandstone (TMS) which forms the mountain ranges is an important - if not the most important - aquifer in the area. Because it consists of pure, fractured sandstone, TMS water has a low salt concentration and the aquifer has a comparatively high transmissivity. Where the aquifer is underlain by less permeable formations, fountains may be found. Where it is overlain by less permeable formations, it becomes confined and water may drain along joints, fractures and faults into overlying aquifers.

Over large areas, especially on the southern side of the Breede River Valley, TMS is overlain by sediments of the Bokkeveld Group which consist of four sandstone and four shale formations (Greeff, 1990). Especially, the shale contains considerable amounts of salt and in the immediate vicinity of the TMS boundary, a noticeable increase in the level of dissolved salts can already be detected. Depending on the degree of fracturing, low- to high-yielding boreholes occur. It seems that water circulating in the more fractured zones is less

mineralised, possibly because the available salts have already been leached from the walls of these preferred major pathways, while considerable quantities of salt may still be trapped in the pore water of the matrix.

Within the area of investigation, rocks of the Witteberg Group occur along the Vink River near the Worcester - Robertson main road, where two sites were sampled. They were of a quality acceptable for human consumption.

Formations of the Karoo Sequence were not encountered within the study area.

Water in the Enon Formation is usually of very poor quality as evidenced by high EC values measured in a number of test holes drilled east of Robertson, where Enon Formation over Bokkeveld Group was observed (Jolly, 1990). Near the main recharge areas at the foot of the Langeberg Mountains, water of good quality (24 mS/m) was struck in a high-yielding borehole.

Water quality in the alluvium varies. Bertram reports conductivities between 10 and 87 mS/m in production boreholes used for irrigation. Flügel (1989c) measured between 100 and 600 mS/m in test boreholes, probably because most of them were near irrigated fields. The shallow ground water is often influenced by irrigation return flow and/or by evaporation from the near surface-water table.

Aquifers in the Malmesbury Formation are also mineralised. Similar to observations in the Enon aquifer, its salt concentration may be astonishingly low (± 5 mS/m) near the Worcester Fault where it is recharged from the adjoining TMS.

Jolly has summarised the quality information from Wittingham, Greeff and Bertram, together with his own data and presented the following mean TDS-values for the different aquifers:

Table 2.1: TDS-values for the geological formations found between H4M017 and H5M004 (after Jolly, 1990).

Formation	TDS [mg/l]
Alluvium	423
Ecca Group	892
Dwyka Group	1475
Witteberg Group	1753
Bokkeveld Group	586
Table Mountain Group	92
Malmesbury Group	688

It must be stressed that, with the exception of the TMS, the variability of the quality in the different aquifers is high. This is illustrated in Table 4 of the report by Jolly (1990) where mean values for Bokkeveld and Alluvium, east of Robertson, are nearly a factor 2 higher than in the Vink River area, and by the high standard deviations of the mean TDS cited in Appendix 1 of the report by Bertram (1990). The major factors influencing the quality within an aquifer seem to be: (i) the boreholes' position within the aquifer and relative to the recharge areas, (ii) the degree to which it is fed by major fractures and (iii) whether irrigation return flow occurs.

2.3.4 YIELD

The yield of boreholes depends mainly on the degree of jointing and fracturing of the formations encountered. Because of widespread fracturing of the TMS, high-yielding boreholes are easier to locate in this formation than in the other secondary aquifers. However, major faults and highly fractured zones cut through most formations. This can explain the observation by Bertram (1990, p.18) that from boreholes used for irrigation, the highest mean yields (10,5 to 10,8 l/s) are recorded for the Bokkeveld Group and the highest individual yield (28,3 l/s) for a hole in the Malmesbury Formation.

2.4 IRRIGATION IN THE BREEDE RIVER

Irrigation in the Breede River Valley started in the 18th century (Flügel, 1989b) and has expanded ever since. Today the greater portion of the irrigated lands, comprising some 45 000 ha, is situated between Worcester and Bonnievale (Beuster *et al.*, 1990).

According to R. Blake¹, the irrigation history in the middle Breede River Valley can be divided into four overlapping phases:

- (i) pre 1889: small-scale development of the tributary areas
- (ii) 1898 - 1918: development of the main river flood plain
- (iii) 1918 - 1970: intensification of the tributary irrigation
- (iv) since 1970: development of the Greater Brandvlei Dam

The maximum demand for irrigation water exists during the growing season in the spring- and summer months, while rainfall and the resulting run-off occur mainly in the winter. Storage facilities are, therefore, essential.

¹ In the middle eighties, R. Blake from the HRI has made an assessment of the then existing data base in the central Breede River Valley. In this internal report of the DWA, the development of the irrigation in the valley and the hydrology and salinity of the river are described. Further aspects of the study are: data availability, irrigation requirements from the Greater Brandvlei Dam, dam operation and mass balance calculations. The author concluded that monitoring was neither adequate for model verification nor for management of the scheme.

Farms in the upper reaches of the tributaries receive irrigation water from farm dams in which run-off from the tributaries is stored. These supplies are often augmented by water from fountains and boreholes. In the Poesjesnels River Valley, a few farms also receive water through a private pumping scheme out of the Le Chasseur Canal. Nearer to the Breede River, five canals provide irrigation water (see Fig. 2.6):

- The Le Chasseur Canal with an off-take into the Poesjesnels River Valley runs on the right side of the Breede River from the Greater Brandvlei Dam to Robertson.
- The Goree Canal diverts water from the Le Chasseur Canal and supplies water on the left side of the Breede River as far down as the Vink River.
- The Robertson Canal diverts water from the Breede River upstream of the Vink River mouth and ends near the Kogmanskloof River.
- The Angora Canal diverts water from the Breede River upstream of the Klaas Voogds River and provides water on the right valley side down to Bonnievale.
- The Zanddrift Canal begins upstream of the Kogmanskloof River mouth. It supplies the left side of the Breede River down to Bonnievale and further down on both sides.

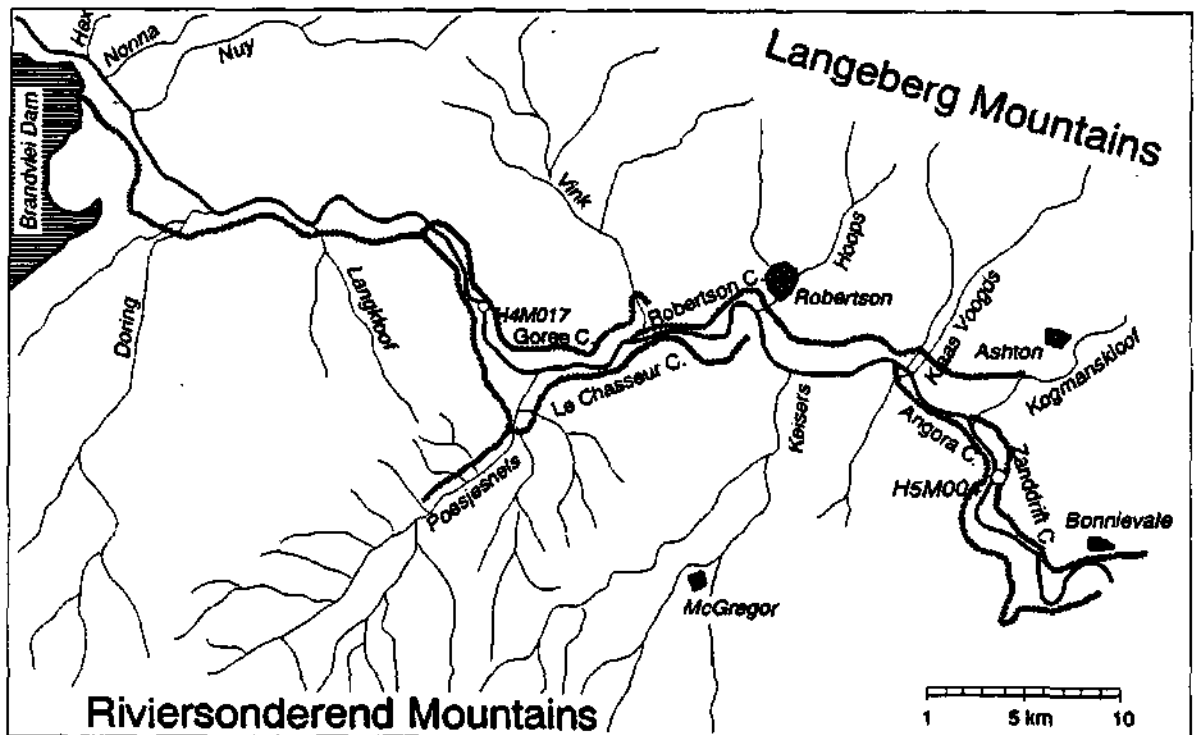

Figure 2.6: Main irrigation canals in the middle Breede River catchment.

Lastly, there are more than 20 pumps between the Le Chasseur weir H4M017 and the weir H5M004 at Secunda that withdraw water for pumping schemes and riparian owners.

The main dam in the catchment is the Brandvlei Dam which, together with the natural flow in the Breede River, supplies all the irrigation water for these canals and pumps.

The dam was built in 1922 as Lake Marais with a capacity of $45,8 \cdot 10^6 \text{ m}^3$. In 1950, it was enlarged to $95,3 \cdot 10^6 \text{ m}^3$. After the construction of the Kwaggaskloof Dam, which began in 1968 and after raising the wall of the Brandvlei Dam, it was named the Greater Brandvlei Dam. Since 1983, it has a full supply-level capacity of $474,7 \cdot 10^6 \text{ m}^3$ (Anon., 1986) and 15 irrigation schemes depend on it (Flügel & Howard, 1987b). The dam is an off-channel storage dam which receives most of its inflow from its own catchment and feeder canals from the Breede River. At the Papenkuil pump station, additional water can be pumped from the Breede River into the dam.

The Breede River is not only the main supply channel for irrigation water, but moreover receives all irrigation return flow. Over the years, this has resulted in an increasing deterioration during times of low flow. Water from the dam is, therefore, not only released for (i) irrigation, but also (ii) for dilution of the river water if the salt concentration exceeds $\pm 70 \text{ mS/m}$ at the Zanddrift Canal off-take.

The build-up of salts in the system has one or more of the following consequences:

- it reduces the yield and/or value of the crops;
- it raises input costs because of the necessary alleviating measures (chemicals and/or additional water are required and/or more expensive irrigation practices must be introduced and operated);
- it limits the area that could still be developed for irrigation farming because some of the limited water available must be used for dilution;
- it requires construction works which separate the irrigation water from the return flow in the Breede River by means of irrigation canal- and pumping schemes or canals for the capture and removal of saline irrigation return flow and
- it necessitates construction works that store and/or convey additional irrigation water to the area.

3. SALINITY RESEARCH IN THE BREEDE RIVER

3.1 REVIEW OF EARLIER SALINITY INVESTIGATIONS

Deterioration of water quality in rivers of the Western Cape due to extensive irrigation practice is a well-known fact (Fourie, 1976). Braune (1988) from the Hydrological Research Institute (DWA) summarised the situation at the end of the Eighties: Due to uncontrolled inflow of saline sources from irrigation return flow and ground-water seepage into the tributaries and the main river, the water quality between H4M017 and H5M004 deteriorates more than five times. Continuous blending with water from the Brandvlei Dam is required during the irrigation season.

The salinisation trend in the Poesjesnels, Kogmanskloof and Vink Rivers has increased significantly: The salinity of the Vink River has more than doubled within the last eight years, while the EC values of the Poesjesnels have increased from a mean of 260 mS/m in 1977 to 380 mS/m in 1987.

The Department of Water Affairs and Forestry is responsible to maintain a water quality below the maximum salt limit for salt sensitive vine of 68 mS/m for 50% and 116 mS/m for 20% of the time, as set by the Department of Agriculture. To keep the water quality in the Breede River at the lowermost canal intake, i.e., the Zanddrift Canal, below these limits, continuous blending with water from the Brandvlei Dam during the irrigation season is necessary.

A dilemma is developing because the water resources are limited, while more irrigation water is required because of the extension of the irrigated areas. At the same time, further water is needed to dilute the river water which deteriorates because of increased irrigation return flow and the additional salt release from newly developed lands. Remedial operational and planning alternatives have been outlined by Forster (1989). One of the options considered for the removal of saline irrigation return flow is a 4,5 km gravity pipeline between Robertson and the Kogmanskloof River where the severest deterioration occurs. This pipeline would allow the building of new canals to be postponed.

The salt that causes the problem stems from four major sources or processes:

- (i) it is contained in the rain, possibly concentrated by evaporation, running off as surface water;
- (ii) it is released from the soil and rock in the unsaturated zone due to natural processes of weathering and denudation;

- (iii) it is concentrated through evapotranspiration as irrigation return flow from irrigated areas and also derived from fertilisers and gypsum application and
- (iv) it is dissolved by ground water circulating in deeper lying formations.

Apart from these diffuse sources, point pollution also occurs in the area.

To some degree, it is possible to control the salt release and to relieve the effects of salinisation:

- The amount of salts dissolved, the degree of concentration and the timing of the salt release can, to some degree, be governed by the irrigation methods, by the time schedule and through the quantities applied.
- The choice of the area and timing of new land development also influence salt release.
- By means of drains, the concentration through evaporation can be reduced in areas with shallow water levels.
- Reduction of leakage from canals and dams helps to reduce evapotranspiration and makes a larger quantity of stored water available for irrigation.
- The effects of salinisation can be altered by optimising dilution practices through water release from the Brandvlei Dam and by separate conveyor systems for the (irrigation water) input and the (return flow) output.

Before considered alleviating actions can be taken, the relative importance of the various contributing sources or processes must be known. They have been investigated in a number of projects.

One of the first researchers who worked in the area was Greeff from the University of Stellenbosch who took water samples from boreholes in the various formations between the Brandvlei Dam and Robertson. He looked into the chemical composition of the ground water and calculated the quantities of salt produced from the various boreholes. Later he concentrated on salt content of Bokkeveld soils, salt release from newly developed land, ground-water flow and salt transport.

At the same time, Moolman, also from the University of Stellenbosch, started to investigate irrigation practices, processes in the soil and irrigation return flow.

By the middle of the eighties, Ninham Shand had started with modelling irrigation return flow in the area.

About the same time, the consulting engineers, Murray Biesenbach and Badenhorst, began to monitor the flow, abstraction, rejects and EC of the Robertson Canal, as well as farm dam storage and cropping patterns in the area served by this canal.

Around 1986, the Hydrological Research Institute of the Department of Water Affairs and Forestry became more involved in the Breede River and a Breede River Salinity Research Program was launched. This program concentrated on:

- (i) *Salinisation trends, water- and salt balances* based on collected daily, in places hourly, water-level and EC data at gauging stations along the Breede River (3 stations), its major tributaries (5), irrigation canals (4) and the Greater Brandvlei Dam (2 stations). Water samples were also taken, rainfall measured and irrigation monitored.
- (ii) *Soil- and river-water salinisation* based on tensiometer-, water-level-, EC- and rainfall data. Soil samples were also analysed.
- (iii) *Irrigation return flow* based on EC-, temperature and discharge measurements in 17 drains taken three times a week. Irrigation and crop data were also collected.
- (iv) *Mapping of irrigated land* in the catchment based on satellite imagery (Lourens *et al.*, 1987).

An exploration drilling program by the Directorate of Geohydrology started in 1987. It was followed by a borehole census (Bertram, 1989) which extended on previous surveys by Wittingham (1976) from the Geological Survey and Greeff (1978).

The Institute for Ground-water Studies began in 1988 to look into the isotopic composition of the ground- and surface water in the Breede River area.

Findings of these investigations are discussed according to the sources or processes responsible for the salt or its concentration as set out above.

3.1.1 SURFACE WATER

Howard (1986) from the HRI determined the electrical conductivity of the Breede River water in March 1986. Figure 3.1 shows that the fastest increase is observed between the Zanddrift Canal off-take, approximately 13 kilometres south-east of Robertson, and the weir H5M004 at Secunda. The deterioration is mainly ascribed to the uncontrolled inflow of saline sources, e.g., from irrigation return flow and ground-water seepage into the tributaries and the main river.

Kienzle and Flügel, also from the HRI, start their investigations by evaluation of collected surface-water data. In 1988, they report on the data captured and present preliminary results. They supply yearly tables, list daily EC and monthly means, other time series data and plot seasonal behaviour of TDS-levels, weighted salinity and discharge, as well as seasonal behaviour of EC with 95% confidence limits.

Their findings can be summed up as follows: The Middle Breede River deteriorates progressively, but increased releases from the Brandvlei Dam balance the salinity level. The salinity of three monitored tributaries increased significantly, probably as a result of

extension of irrigated areas and a change in irrigation technique. Fluctuations in the stream salinity are closely related to the irrigation season. The amplitude of the seasonal fluctuation increases in a downstream direction.

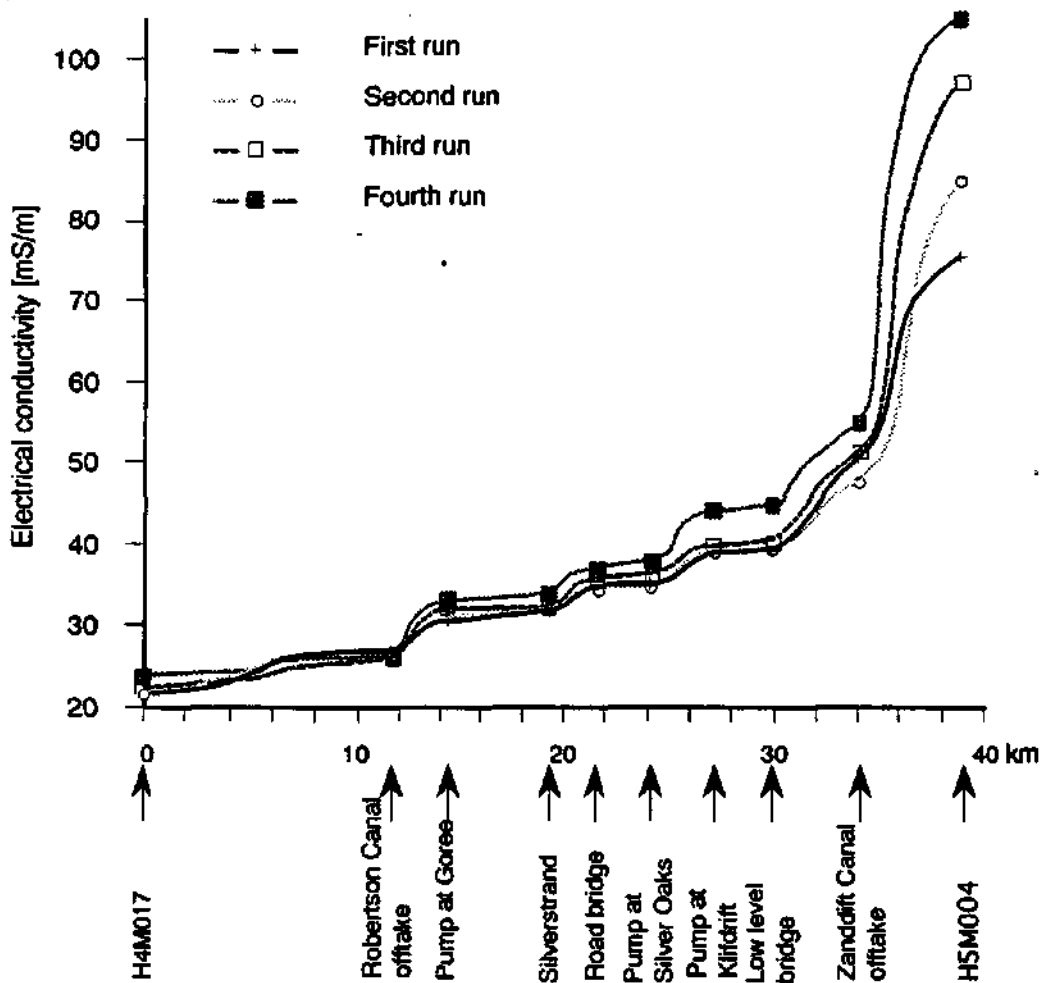

Figure 3.1: Conductivity profile of the Breede River taken in March 1986 (after Howard).

Kienzle (1989a) modified salt-load calculations and conducted a trend analysis. He comes to a number of conclusions regarding the dependence of the salt load in the Breede River. These are based on (i) summary statistics of monthly mean EC data; (ii) mean TDS-values during the irrigation season and annual cumulative releases from Brandvlei Dam; (iii) salt denudation rates for four sub-catchments over the last three years; (iv) crop water quality criteria and actual daily EC at H5M006 over the last four years; (v) yearly tables of daily EC values for the hydrological year 1987/88 and (vi) time series plots of TDS, salt load and discharge for weirs H1R01Y, H3H011, H4M017, H4M018 and H5M004, as well as weighted salinity and stage levels for the remaining stations.

In the following HRI report (Kienzle, 1990), the data for the hydrological year 1989 are presented. Kienzle concluded: The statistical methods applied, provide the means of

identifying data sets where significant monotone changes in the salinity levels are occurring and supply an estimate of the magnitude of the trend over the record period.

The hydrological year 1989 has produced relatively high discharges with corresponding low TDS, but high salt load outputs. Almost all trends calculated with 1989 data resulted in lower slopes.

Greeff (1990) reported the following conclusions from his research in the Poesjesnels River area: With a total size of the catchment of 1794 ha, the average irrigation water applied is $\pm 13 \cdot 10^6 \text{ m}^3$ annually during an eight-months' period. Input from the Le Chasseur Canal is $6,78 \cdot 10^6 \text{ m}^3/\text{a}$. The total input for the catchment is $90 \cdot 10^6 \text{ m}^3/\text{a}$ of which only one-tenth flows out.

Two tributaries of the Poesjesnels River carry return flow seepage with salinities of up to 3000 and 7000 mg/l respectively. The annual salt load passing the weir H4M018 in the Poesjesnels River is 7674 tons. According to model calculations, in-flowing ground water contributes $203\ 000 \text{ m}^3$ with 609 tons of salt. In the context of the present investigation, importance is attributed to the findings that ground water contributes less than 10 percent to the salt output of the investigated area.

3.1.2 UNSATURATED ZONE

One of the first researchers who worked in the area was Greeff (1978). He took water samples from boreholes in the various formations between the Brandvlei Dam and Robertson. He looked into the chemical composition of the ground water and calculated the quantities of salt produced from the various boreholes. Later he concentrated on salt content of Bokkeveld soils and weathered rock, salt release from newly developed land, ground-water flow and salt transport (Greeff, 1990). He found a maximum of 5658 mg/l of salt leached from one kilogram of source rock in one litre water. Especially, where irrigation land is newly developed, salts are leached mainly by interflow and transported to the river. By contrast less than 10 percent of the salt output from his investigation area was derived from ground-water sources.

3.1.3 IRRIGATION RETURN FLOW

In the late seventies, Moolman started to investigate irrigation practices, processes in the soil and irrigation return flow (cf. Moolman *et al.*, 1983 and Moolman, 1989).

Lautner (1989) from the HRI investigated the salt- and water balance of 17 drains in the area. She determined the average irrigation requirement as $34 \text{ m}^3/\text{ha}/\text{d}$ and regarded a leaching fraction of between 10 and 15% as representative. The data on which the deductions were made are summed up in Table 3.1.

Table 3.1: Irrigation return flow data from the report by Lautner (1989).

Station	Month	Return flow	Irrigation	Leaching	Supply	Return	Factor	Input	Output	Gain/Loss	Input	Output	Gain/Loss	Mean	Leaching	
		[m ³ /d]	[m ³ /d]	[fraction]	[EC]	[EC]		[l/r*Supp]	[Return*Flow]	[%]	[l/r*Supp]	[Return*Flow]	[%]		[fraction]	
60	November	1158	4900	23.6%	31.5	162	5.1	154350	187596	21.5	154350	187596	21.5		0.24	
	December	1218	4900	24.9%	24.7	187	7.6	121030	227766	88.2	121030	227766	88.2		0.25	
	January	544	4900	11.1%	22.6	162	7.2	110740	88128	-20.4	110740	88128	-20.4		0.11	
	February	475	4900	9.7%	19.0	164	8.6	93100	77900	-16.3	93100	77900	-16.3	18	0.10	
	50	November	172	8750	2.0%	31.5	278	8.8	275625	47810	-82.7		incomplete			
	December	199	8750	2.3%	24.7	377	15.3	216125	75023	-65.3		incomplete				
	January	112	8750	1.3%	22.6	434	19.2	197750	48008	-75.4		incomplete				
	February	43	8750	0.5%	19.0	458	24.1	166250	19694	-88.2		incomplete				
	27	November	1987	13300	14.9%	31.5	189	6.0	418950	375543	-10.4	418950	375543	-10.4		0.15
	December	1676	13300	12.6%	24.7	231	9.4	328510	387156	17.9	328510	387156	17.9		0.13	
	January	1210	13300	9.1%	22.6	228	10.1	300580	275880	-8.2	300580	275880	-8.2		0.09	
	February	1132	13300	8.5%	19.0	243	12.8	252700	275076	8.9	252700	275076	8.9		0.09	
26	November	492	13650	3.6%	31.5	429	13.6	429975	211068	-50.9		incomplete		2		
	December	622	13650	4.6%	24.7	448	18.1	371155	278656	-17.4		incomplete				
	January	372	13650	2.7%	22.6	446	19.7	308490	165912	-46.2		incomplete				
	February	294	13650	2.2%	19.0	445	23.4	259350	130830	-49.6		incomplete				
	62	November	1866	8750	21.3%	31.5	111	3.5	275625	207126	-24.9	275625	207126	-24.9		0.21
	December	2799	8750	32.0%	24.7	121	4.9	216125	338679	56.7	216125	338679	56.7		0.32	
	January	2004	8750	22.9%	22.6	143	6.3	197750	286572	44.9	197750	286572	44.9		0.23	
	February	1426	8750	16.3%	19.0	136	7.2	166250	193936	16.7	166250	193936	16.7	46	0.16	
	61	November	786	3500	22.5%	31.5	199	6.3	110250	156414	41.9	110250	156414	41.9		0.22
	December	372	3500	10.6%	24.7	185	7.5	86450	68820	-20.4	86450	68820	-20.4		0.11	
	January	467	3500	13.3%	22.6	170	7.5	79100	79300	0.4	79100	79300	0.4		0.13	
	February	579	3500	16.5%	19.0	196	10.3	66500	113484	70.7	66500	113484	70.7	23	0.17	
9	November	899	15750	5.7%	31.5	288	9.1	496125	258912	-47.8		incomplete				
	December	2203	15750	14.0%	24.7	189	7.7	389025	416367	7.0		incomplete				
	January	1417	15750	9.0%	22.6	152	6.7	359950	215384	-39.3		incomplete				
	February	1788	15750	11.4%	19.0	193	10.2	299250	345084	15.3		incomplete				
	7	November	3473	45500	7.6%	31.5	465	14.8	1433250	1614945	12.7		incomplete			
	December	2730	45500	6.0%	24.7	546	22.1	1123850	1490580	32.6		incomplete				
	January	1607	45500	3.5%	22.6	647	28.6	1028300	1039729	1.1		incomplete				
	February	1305	45500	2.9%	19.0	506	26.6	864500	660330	-23.6		incomplete				
	19	November	172	1707	10.1%	31.5	578	18.3	53771	99416	84.9	53771	99416	84.9		0.10
	December	311	2019	15.4%	24.7	595	24.1	49869	185045	271.1	49869	185045	271.1		0.15	
	January	259	2475	10.5%	22.6	382	25.8	55935	150738	169.3	55935	150738	169.3		0.10	
	February	164	2019	8.1%	19.0	613	32.3	38361	100532	162.1	38361	100532	162.1	172	0.08	
46	November	1452	516	281.4%	31.5	552	17.3	16254	801504	4831.1		incomplete				
	December	1624	516	314.7%	24.7	570	23.1	12745	925680	7163.0		incomplete				
	January	1547	516	299.8%	22.6	566	25.0	11662	875802	7408.4		incomplete				
	February	1192	516	231.0%	19.0	570	30.0	9804	679440	6830.2		incomplete				
	47	November	181	430	42.1%	31.5	281	8.9	13543	50861	275.3	13543	50861	275.3		0.42
	December	138	430	32.1%	24.7	270	10.9	10621	37260	250.8	10621	37260	250.8		0.32	
	January	112	430	26.0%	22.6	230	11.1	9718	28000	188.1	9718	28000	188.1		0.26	
	February	69	430	16.0%	19.0	242	12.7	8170	16698	104.4	8170	16698	104.4	205	0.16	
	25A	November	95	2365	4.0%	31.5	202	6.4	74498	19190	-74.2	74498	19190	-74.2		0.04
	December	86	2365	3.6%	24.7	190	7.7	58416	16340	-72.0	58416	16340	-72.0		0.04	
	January	43	1650	2.6%	22.6	195	8.6	37290	8385	-77.5	37290	8385	-77.5		0.03	
	February	112	1650	6.8%	19.0	134	7.1	31350	15008	-52.1	31350	15008	-52.1	69	0.07	
25B	November	112	3010	3.7%	31.5	253	8.0	94815	28336	-70.1	94815	28336	-70.1		0.04	
	December	95	3010	3.2%	24.7	237	9.6	74347	22515	-69.7	74347	22515	-69.7		0.03	
	January	52	2100	2.5%	22.6	236	10.4	47460	12272	-74.1	47460	12272	-74.1		0.02	
	February	121	2100	5.8%	19.0	207	10.9	39900	25047	-37.2	39900	25047	-37.2	63	0.06	
	64	January	10	63	15.9%	22.6	1845	81.6	1424	18450	1195.8	1424	18450	1195.8		0.16
	February	9	63	14.3%	19.0	1811	95.3	1197	16299	1261.7	1197	16299	1261.7	1229	0.14	
63	January	484	1115	43.4%	22.6	499	22.1	25199	241516	858.4	25199	241516	858.4		0.43	
	February	302	1115	27.1%	19.0	500	26.3	21185	151000	612.8	21185	151000	612.8	736	0.27	
	65	January	52	3634	1.4%	22.6	2079	92.0	82128	108108	31.6		incomplete			
	February	86	3634	2.4%	19.0	1560	82.1	69046	134160	94.3		incomplete				
	66	January	233	2350	9.9%	22.6	793	35.1	53110	184769	247.9	53110	184769	247.9		0.10
	February	242	2290	10.6%	19.0	767	40.4	43510	185614	326.6	43510	185614	326.6		0.11	
17 Sms	SUM	46782	500918			1437.8	26305	1171.8	12204309	15496189		3821700	4952757			
	MEAN	779.7	8348.63	9.3%	24	436	20	203405	258270	27.0	100571	130336	29.6	230	0.15	

Murray Biesenbach and Badenhorst (1989) monitored the flow, abstraction, rejects and EC of the Robertson Canal, as well as farm dam storage and cropping patterns in the area served by this canal. Some deductions are based on long-term observations of an unexplained gain of the Breede River System in the order of 3 - 4 m³/s between the

Brandvlei Dam and the Zanddrift Canal (L. Bruwer, personal communication). With the help of the IRRISS model, developed by S.F. Forster from the Department of Water Affairs and Forestry, water- and salt-balance calculations were conducted. Most of their findings are summarised in a print-out of the IRRISS model in Table 3.2.

Table 3.2: Output of the IRRISS model (after Murray, Biesenbach and Badenhorst, 1989).

DESCRIPTION	[1000 m ³]	[% TOTAL INTAKE]
Diversion into canal	21 763	-
Canal export	- 9 406	-
Supply from the canal (WSI)	12 357	90,44
Supply from water source 2	1 306	9,56
TOTAL WATER SCHEME INTAKE	13 663	100,00
Canal evaporation	- 48	0,35
Canal seepage loss	- 3 200	23,42
Canal reject	- 1 257	9,20
Farm dam evaporation	- 27	0,20
Farm dam seepage loss	- 455	3,33
TOTAL LOSSES	- 4 987	36,50
Seepage lost to ground water	0	0,00
Return flow from seepage loss	3 655	26,75
Direct application	1 393	10,20
Farm dam releases	7 321	53,58
TOTAL WATER APPLIED	8 714	63,78
Crop water requirement	7 702	56,37
Crop water consumption	7 702	56,37
Crop water deficit	0	0,00
Percolation below root zone	1 541	11,28
Percolation lost to ground water	0	0,00
Average leaching fraction		20,11
Return flow from irrigated soil	1 541	11,28
TOTAL SCHEME RETURN FLOW	5 196	38,03

For an irrigated area of 1064 ha over a 200-day irrigation season, they found an irrigation return flow of 11,3% with a salinity of 2980 mg/l.

Since 1988 Ninham Shand has developed an operational hydrological Daily Hydrosalinity Model *DISA* for optimum operation of the Breede River system which allows a.o. to predict the influence of irrigation expansion on the salinity in the Breede River (Beuster *et al.*, 1990). The primary goal of much of the research in the Breede River is to supply the

necessary data for incorporation in such model(s). Results of a model run are shown in Table 3.3.

Table 3.3: Output of the DISA model for the period June 1985 to April 1986.

DISA	IN						OUT						Return flow	% Irrigation	
	Date	InitStor	U/S	Recharge	Can Rej	Rain	Gain	Evap	Can Abs	Pump Abs	D/S	StoRte			Loss
8506	2 095	148 257	1 415	4 169	685	156 621	607	8 865	1 193	144 370	3 871	158 906			
8507	3 871	231 411	1 415	4 358	1 581	242 636	425	9 160	1 193	230 623	4 079	245 480			
8508	4 079	206 001	1 415	4 339	509	216 343	709	9 160	1 193	203 690	4 406	219 158			
8509	4 406	74 320	1 415	4 157	275	84 573	981	8 865	1 193	71 779	4 219	87 037			
8510	4 219	39 541	1 415	1 436	763	47 374	1 179	9 160	3 024	29 093	6 937	49 393	604	6%	
8511	6 937	32 760	1 415	1 322	242	42 676	1 868	8 865	3 130	28 283	3 083	45 229	1 138	11%	
8512	3 083	27 757	1 415	1 408	269	33 932	2 180	9 160	3 169	20 101	2 627	37 237	1 890	17%	
8601	2 627	19 264	1 415	1 418	39	24 763	2 568	9 160	3 199	10 716	2 679	28 322	2 144	20%	
8602	2 679	15 912	1 415	1 155	157	21 318	2 102	8 274	3 215	8 595	2 401	24 587	1 854	18%	
8603	2 401	16 803	1 415	1 426	294	22 339	1 732	9 160	3 143	9 025	3 030	26 090	2 336	21%	
8604	3 030	35 537	1 415	1 340	165	41 487	1 109	8 812	3 025	30 219	2 152	45 317	2 415	23%	
All units in 1000 m ³ . - According to 1987 figures - 11600 ha above H4M17, 9100 ha between H4M17 and H5M04												MEAN:	16.5%		
InitStor	Start of month river channel storage						(Kogmans Irrigation area = 2000 ha)								
U/S	Inflow at H4M17 + Kogmanskloof inflow + Robertson point pollution inflow														
Recharge	Fractured bedrock contribution to flow in main river channel														
Can Rej	Le Chasseur & Robertson Canal rejects to main river channel														
Rain, Evap	Rain on, and evaporation from main river channel														
Can Abs	Robertson + Angora + Sanddrif Canals						Capacity(m ³ /sec):	Robertson Canal	1.70	40.00%					
Pump Abs	Pump abstraction from main river channel (incl. Kogmans)							Angora Canal	0.71	16.71%					
D/S	Outflow at H5M04							Sanddrif Canal	1.84	43.29%					
StoRte	End of month river channel storage							TOTAL	4.25	100.00%					
% Irrigation = (Return flow-Recharge)/(Can Abs + Pump Abs - Can Rej)															

A. Görgens from Ninham Shand (personal communication) stresses that monthly return flow figures are unrealistic because of lagging response of the alluvial aquifer. The seasonal total return flow of 16,5% in the table above does not include return flow from canal losses, etc. If they are included, the figure changes to 21,6%.

For early March 1982, they obtained an irrigation return flow value of 0,74 m³/s (i.e. 27% of the irrigation water applied) for early March 1982 and a salt-balance surplus of 18 kg/ha-d between H4M017 and H5M004.

3.1.4 GROUND WATER

At the end of the seventies Greeff (1978), had taken water samples from boreholes in the various formations between the Brandvlei Dam and Robertson. He looked into the chemical composition of the ground water and calculated the quantities of salt produced from the various boreholes.

Flügel has addressed ground-water related topics in a number of reports and publications. He reported a.o. on ground-water dynamics (1989b and 1989c) and on the ground-water contribution to the salinisation of the Breede River (1990). He based his findings on EC- and water-level observations in the test holes drilled in the area, on irrigation return flow measurements, as well as EC- and stage height measurements at gauging weirs. Flügel concluded that there were (i) a deep, artesian, saline aquifer; (ii) a shallow alluvial less salty aquifer and (iii) an aquifer in the sandy top layer of the "island" in the Breede River, south of Robertson, which responded to irrigation cycles. Mainly based on salt-balance calculations and assumed irrigation efficiencies, he concluded that "all tributaries show a dominant influence of groundwater seepage" (Flügel, 1989b) from the deep aquifer.

He found that in boreholes monitored by the HRI, the ground-water level under non-irrigated land is always deeper than 15 m and the EC is higher than 1500 mS/m, while under irrigated land, the level is less than 3 m deep and the conductivity between 250 and 600 mS/m (Flügel, 1989b). The shallow ground water is flowing towards the Breede River with gradients between 0,7 to 0,9%. It responds to irrigation, depending on the irrigation technique and its salinity varies between 0,4 and 6,4 g/l¹ (Flügel, 1989c).

In November, he reported to the Fourth South African National Hydrological Symposium (Flügel, 1989c): Ground water in the fractured bedrock is under artesian pressure. It is saline and has a TDS between 3 and 12 g/l. Its gradient is directed towards the Breede River, but is not corresponding to irrigation cycles. Ground-water inflow from the fractured bedrock contributed in 1988 about 7% of the total outflow at H5M004 and about 23% of the salt output. The ground-water gradient in the bedrock varies between 0,8 and 1,3%.

In the 4th BRSRP report (Flügel, 1990), water- and salt balances were calculated for the Breede River between H4M017 and H5M004 to estimate the saline ground-water seepage. Water- and salt input from the main tributaries and rainfall were accounted for. Inflow of irrigation return flow from the artificial drainage system was included. Inaccuracies remain because the minor tributaries were not included and because of limited weir calibration accuracy.

Flügel (1989b) also postulates that salt dissolution from fertilisers (including soil reactions with gypsum) and soil weathering are negligible. For 90% irrigation efficiency, i.e., 10% leachate, the EC of the return flow would be sufficiently high to explain the measured salinity of the tributaries. For more realistic efficiencies of 70 - 80 percent, the salinity of the tributaries would be too low. The salt deficit is ascribed to ground-water contributions.

Flügel and co-workers furthermore investigated processes in the unsaturated zone and irrigation return flow: Volkmann (1990) concentrated his research on soil salinisation on the

¹ These values do not quite agree with conductivities of between 250 and 600 cited above.

"island" south of Robertson. His findings, as far as they are regarded relevant to the ground-water aspect, are as follows: Water-level observations in deep boreholes G 33573, 84, 90, 91 and 92 do not suggest multiple ground-water horizons, although the occurrence of artesian water in G33591 may indicate separated aquifers. Considerable daily EC variations were observed (p. 99) which cannot be linked to water-level variations. A sudden increase in salinity was observed in most boreholes in January 1989.

It was mentioned earlier that the Breede River Salinity Research Program ended prematurely when the data collection activities were halted in March 1990. All scientific staff that worked on the project has since left the Department. Data evaluation and reporting have not been completed.

The Directorate of Geohydrology of the Department of Water Affairs and Forestry has assisted the HRI with studies on the ground water occurring in the area.

- (i) A first survey of borehole data and ground-water usage between Bains Kloof and the Vink River had been undertaken by Wittingham (1976).
- (ii) During 1987, 49 exploration boreholes were drilled on either side of the Breede River between Robertson and the Klaas Voogds River and 23 along the lower Vink River. These holes vary in depth between ± 20 m and 100 m¹. Pumping tests were carried out at three of the sites (Jolly, 1990).
- (iii) In 1989, a borehole survey of holes used for irrigation was carried out between the Greater Brandvlei Dam and the intake of the Zanddrift Canal. Information from 150 holes on depth of hole, yield, pumping rate, annual abstraction, conductivity and geological formation was collected. Data on irrigation type and quantities, as well as crops irrigated, were also included in the report (Bertram, 1989).

Jolly (1990) reported on the exploration drilling. The Vink River area was selected to ascertain the volume of ground-water seepage within a tributary valley of the Breede River.

Only summarised aquifer test results are given in his report. The reported transmissivities vary between 2,9 - 59 m²/d (alluvium) and 4,1 - 417 m²/d (bedrock) with storativities given as 0,00016 - 0,03333 and 0,00051 - 0,00023 respectively. Results of individual pumping tests were not reported.

Jolly comes to the conclusion that there are two aquifers. The ground-water contribution to the flow in the Breede River is 50 576 m³/d of which 96% is derived from fracture zones in the bedrock. The total salt contribution of the ground water is 14647 t/a. Also 96% of this

¹ Staff of the HRI measured water levels and electrical conductivity in these holes on a weekly basis until March 1990. Murray Biesenbach and Badenhorst continued with the data collection for a further year.

quantity stem from the fractured aquifer which has salt concentrations ranging from 92 to 1753 mg/l.

The Directorate of Geohydrology's hydrocensus covered boreholes used for irrigation in the area from the Greater Brandvlei Dam, Villiersdorp and Nuy down the Breede River Valley to the Zanddrift weir, including the tributaries Poesjesnels-, Vink-, Hoops- and Keisers Rivers. Information was gathered on the occurrence, quality, availability and use of ground water. One-hundred and fifty-five holes used for irrigation were included in this survey.

Bertram found that a total of 10,8 million cubic metres of ground water is abstracted annually from this area. The volumes being withdrawn increased since 1977. Much more water is abstracted from the southern river valleys than from the northern ones.

The average electrical conductivity of the ground water used for irrigation is 70 mS/m. There is a significant difference in the quality of the water from different geological formations, but it seems impossible to identify the origin of the water by macro element analysis. Where alluvium covers a specific formation, a negative influence on the quality of the ground water is noticeable.

No significant correlation between yield and geological formation was found, although the presence of an alluvial cover usually coincided with higher yields (Bertram, 1989).

At the request of the Hydrological Research Institute and on contract for the Water Research Commission, the Institute for Ground-water Studies has carried out a pilot study on the isotopic and chemical characterisation of ground- and surface water in the area between October 1988 and April 1989. The aim of this study was to establish whether sufficient chemical and isotopic characteristics exist that allow to discern between waters from the different sources in the area.

The results of the pilot study can be summarised as follows: Based on samples taken twice at 24 ground- and surface-water locations for chemical, ^2H and ^{18}O analyses, the chemical composition of ground-water samples indicated that the quality of water from the Malmesbury- and Table Mountain Sandstone Groups stays rather constant in individual boreholes, but quality variations within the aquifers occur. In general, this is also true for the Bokkeveld Group. No individual ions were detected that could be used to characterise aquifers.

The potential of ground water of the three formations mentioned to increase the salinity of the Breede River, appears limited because, in most cases, ground water is of a better quality than irrigation return flow. However, because of the geological situation, ground water from the TMS will have to rise through, e.g., the Bokkeveld and/or other younger formations, before it can discharge into the river. On its way through the Bokkeveld, etc., it may pick up additional salts and raise its TDS-value to the level of the ground water in these

formations. On the basis of the analyses done, the salinity of ground water discharging into the Breede River will probably not exceed 1000 to 2500 mg/l.

In contrast to the surface water, the isotopic composition of ground water in the different aquifers appears to be relatively stable. It could not be decided, at that stage, whether the small variations that were noticed indicated different aquifer response or random variations.

It seemed clear, however, that the use of isotopes alone would not allow to determine the contribution of individual aquifers to the run-off in the Breede River: deuterium and oxygen-18 are related to each other and could not be regarded as independent variables. If suitable sampling times are selected, i.e., especially during droughts, noticeable changes in the isotopic composition of the river water can be expected as it flows downstream. From this changing composition of inflow and outflow between, e.g., H4M017 and H5M004, it should be possible to determine the total contribution from ground water.

The present one-year project attempts to quantify the ground-water contribution to the flow in the Breede River.

3.2 THE PRESENT INVESTIGATIONS

During the project, data on the following aspects were collected which either affect (or reflect processes affecting) the water- and salt balance or indicate the origin of the water: chemical composition, isotope ratios of deuterium, oxygen-18 and strontium, electrical conductivities, rainfall, water levels and river flow rates.

3.2.1 SAMPLING NETWORK

Before the first field visit, all data on the National Ground-water Data Base (NGDB) available for the study area were downloaded to a HydroCom data base, i.e., information for quarter degree sheets 3319CB, 3319CD, 3319DA, 3319DB, 3319DC, 3319DD and 3320CC. On the basis of NGDB data, the data collected by Bertram (1989) and previously gained information, approximately 100 sites were selected for initial sampling. They included most of the sites monitored during the pilot study. Criteria for the selection were representativeness of the various geological formations and good areal coverage. Fountains and flowing boreholes obtained preference, because it was expected that they represent only one aquifer and are less likely to change in quality than holes that are pumped.

The study area was visited four times at quarterly intervals. During the first visit between 28 May and 9 June 1990, 87 boreholes (including one well and seven fountains) were sampled and EC, temperature and water level measured, where possible. Additional geohydrological information was also collected. Changes and/or additions to the pre-selected list occurred, when samples from certain sites could not be obtained or when additional sites were found which would probably improve the representativeness. Also sampled were 11 surface-water sites between the Brandvlei Dam and the weir H5M004 in the Breede River at Secunda. Attempts were made to obtain samples from all flowing tributaries between the weir H4M017 at Le Chasseur and H5M004. The positions of all sites are shown on the accompanying map at a scale of 1:100 000. A list of all Site-id-numbers in the data base, together with the Map numbers and Site descriptions, appears in the Appendix¹.

Based on the already available information and the electrical conductivity measured in the field, chemical analyses of 91 of the 97 samples were carried out². The results of the chemical analyses were used to reduce the number of samples to be analysed for deuterium

¹ A list of all Site-id-numbers in the data base, together with the Map-numbers and Site descriptions, appears in Appendix 1. The sites sampled and the sampling dates can be looked up in Appendices 5 and 6 for the chemical analyses and Appendix 13 for the ²H and ¹⁸O isotope analyses.

² Similar criteria were used for the samples from the exploration boreholes which were measured and sampled by Murray, Biesenbach & Badenhorst.

and oxygen-18, mainly by eliminating samples with similar chemical composition from nearby sites.

Once the aquifer-, chemical- and isotopic information were available, a final sampling network was chosen. During each of the following visits between 3 September to 7 September, 2 to 7 December 1990 and 26 February to 5 March 1991, approximately 55 ground-water and nine surface-water samples were collected for chemical analysis.

Besides the data collected by IGS, HRI's observation network of the Breede River Salination Program was operated on a reduced scale until May 1991 by the Consulting Agricultural and Civil Engineers, Murray, Biesenbach and Badenhorst Inc. (MBB), in Robertson. This task included the operation of recorders at weirs H4M017, H4M018, H4M019, H4H011, H3H011 and H5M004, weekly measurement of the electrical conductivity and temperature along the Le Chasseur, Robertson, Angora and Zanddrift Canals, and measurements of EC, temperature and water levels in the G-numbered observation holes in the *Robertson* and *Vink River areas*. Water samples were taken on a monthly basis at all these sites and at the tributaries Sand, Nels, Hoops and (two) Klaas Voogds Rivers on behalf of IGS.

IGS received copies of the recorder data from Ninham Shand¹, copies of the raw data of the weekly EC measurements, temperatures and water levels from MBB, and hourly flow data² for the mentioned weirs from the Directorate of Hydrology of the Department of Water Affairs and Forestry (DWA).

Copies of some of the data collected previously by the HRI have been received from the HRI, while others were directly downloaded from the DWA's mainframe computer³.

A large number of data has also been taken from reports, e.g., Greeff (1991), Jolly (1990) and Lautner (1989). Copies of the pumping test data from the Poesjesnels River area and from the exploration boreholes near Robertson have been obtained from G.J. Greeff and J.L. Jolly respectively. Brandvlei Dam release data were made available by the Worcester Branch of the DWA.

Rainfall data for stations in Worcester, McGregor and Robertson were abstracted from the Computing Centre for Water Research. The more recent data have been obtained from the Weather Bureau.

¹ Murray Biesenbach and Badenhorst Inc. has operated the network as subcontractors of Ninham Shand. Ninham Shand required the data for the DISA model.

² The hourly data were calculated from breakpoint data digitised from the recorder charts.

³ S. Kienzle supplied the data when he was with the HRI. Later he traced the remaining data on the mainframe and made downloading possible.

DATA BASE

All data that were generated or captured have been entered into a HydroCom data base. These data include all records that were available on the NGDB for Quarter degrees 3319CB, 3319CD, 3319DA, 3319DB, 3319DC, 3319DD and some for sheet 3320CC.

The HydroCom data base comprises the following number of records:

DATA BASE FILE	No of records	Additional records
Basic Information	369	
Penetration rate	11	
Aquifer	114	
Geology	625	
Construction	55	
Hole	94	
Casing	88	
Installation	0	
Discharge	315	
Water level	4527	
Water sample	0	
Field measurement	22	5829+ 6321(Eleccon)
Meter reading	260	
Pumping test	19	
Site selection	1	
Owner	193	
Other identifier	258	
Other data	0	
Site visits	0	
Special cases	0	
References	178	195 (Brefernc)
Search status	15	
Comments	397	421 (Bcomment)
Chemical analyses	1109	
Isotope analyses	274	
Rainfall	16073	
H3H011 (water level and/or EC)	31388	
H4H011 (water level and/or EC)	13581	
H4H017 (water level and/or EC)	30976	
H4H018 (water level and/or EC)	31438	
H4H019 (water level and/or EC)	31449	
H5H004 (water level and/or EC)	30424	
Dam release	1550	

DATA QUALITY

The data collected are generally of good quality. There are, however, a few shortcomings: certain data have apparently not been collected, e.g., pump abstractions from the Breede River and canal flow. Other data, like the seepage return flow recorded, appear suspicious because of the great variability of the leaching fraction (Lautner, 1989, Table 4). Any water-balance approach must take these deficiencies into account.

Other problems were noticed with the following data:

Recorders

Conductivity data recorded during the project period at the weirs are (i) not always reliable and (ii) not continuous. At H5M004¹, for example, an EC value of 115,0 mS/m was recorded for 13. 3. 1991 at 25h65, preceding values were about 10 mS/m and the following ones between ± 10 and 20 mS/m. On the same date, there also appear two readings for the time 0:01 of 8191 mS/m and 8,33 mS/m respectively. Figures 3.2 to 3.7 display flow- and EC data for the six weirs (see Fig. 2.3) and indicate the data quality obtained.

H4M017: Conductivity data corrupt between 1990/11/05 16:00 and 1900/11/27 10:00. Missing data are evident from the graph.

H4M018: Missing conductivity data are evident from the graph.

H4M019: Conductivity data corrupt between 1990/05/17 10:00 and 1990/06/26 11:00. Missing data are evident from the graph. Flow of 11000 recorded on 1990/10/31 at 13:00 (deleted on graph).

H4H011: No flow data.

H3H011: Missing conductivity data are evident from the graph.

H5M004: Conductivity data start 1990/06/21 at 10:00 and are interrupted in January 1991; no conductivity data before 1990/06/21 at 10:00. Flow data for the period 1990/04/18 to 1990/10/01 and after 1991/02/21 are missing.

Electrical conductivity

Conductivity data for all G-numbered holes measured during the project period show a decrease. This decrease by more than a factor 5 reflects a systematic fault, because it is independent of the formations encountered in the holes and their distance from the Breede River. This aspect is later discussed in more detail.

¹ The Department of Water Affairs has changed the codes of measuring stations in the area by adding a "0", e.g., H4M017 has become H4M017. Reference to these stations in the text is according to the codes shown in Fig. #3 or by name.

Figure 3.2: Mean daily flow and conductivity measured at H4H017 between May 1990 and April 1991.

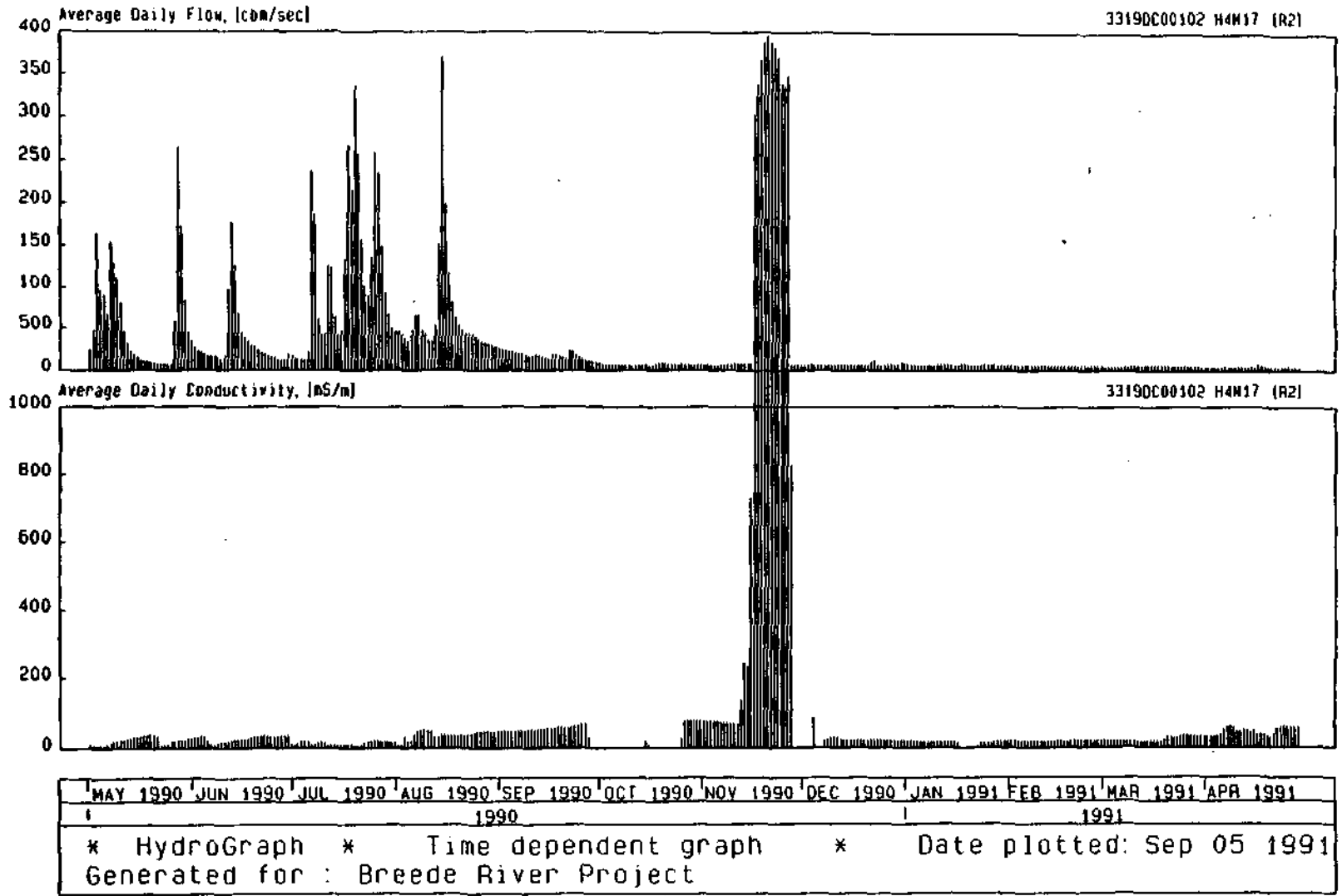

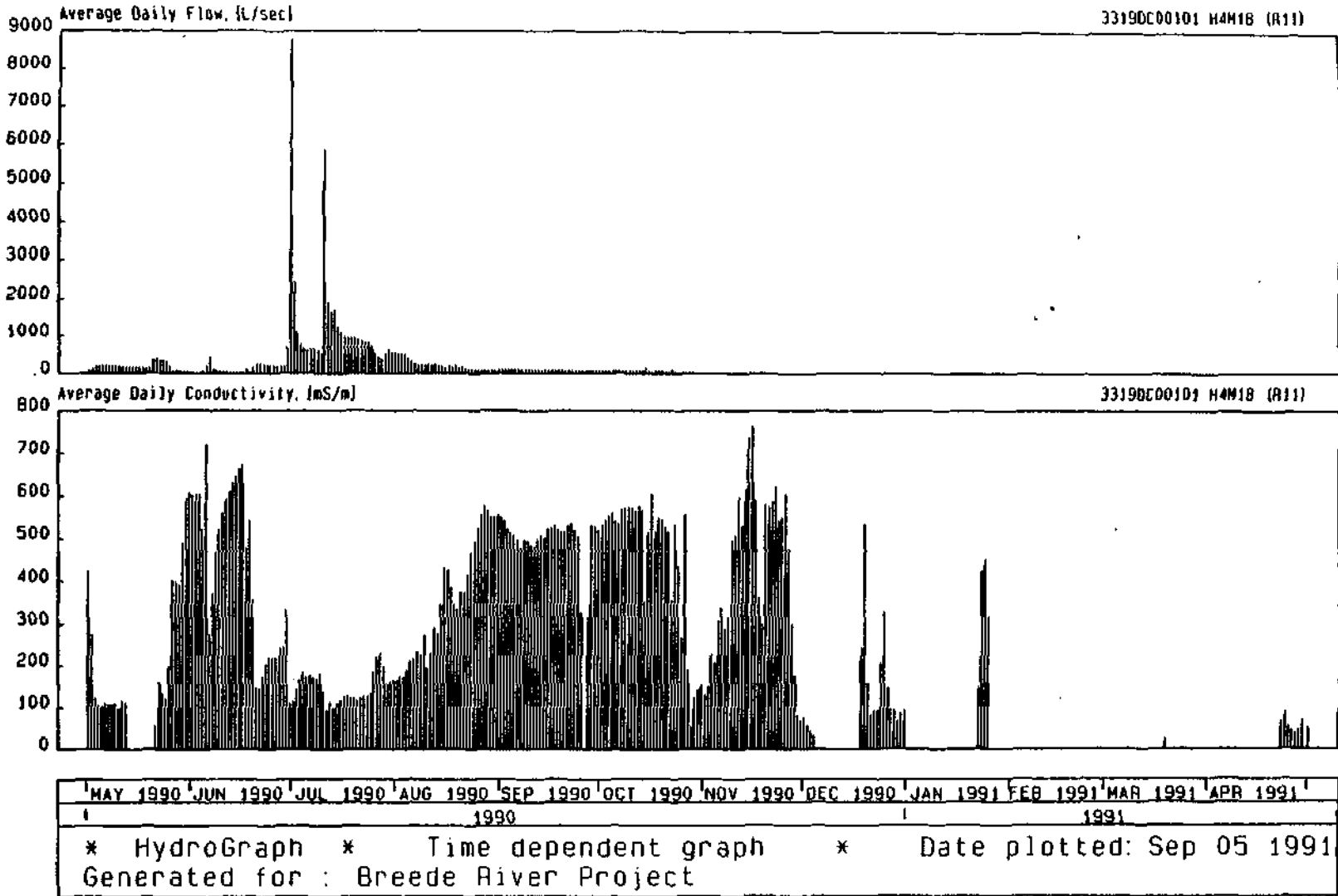
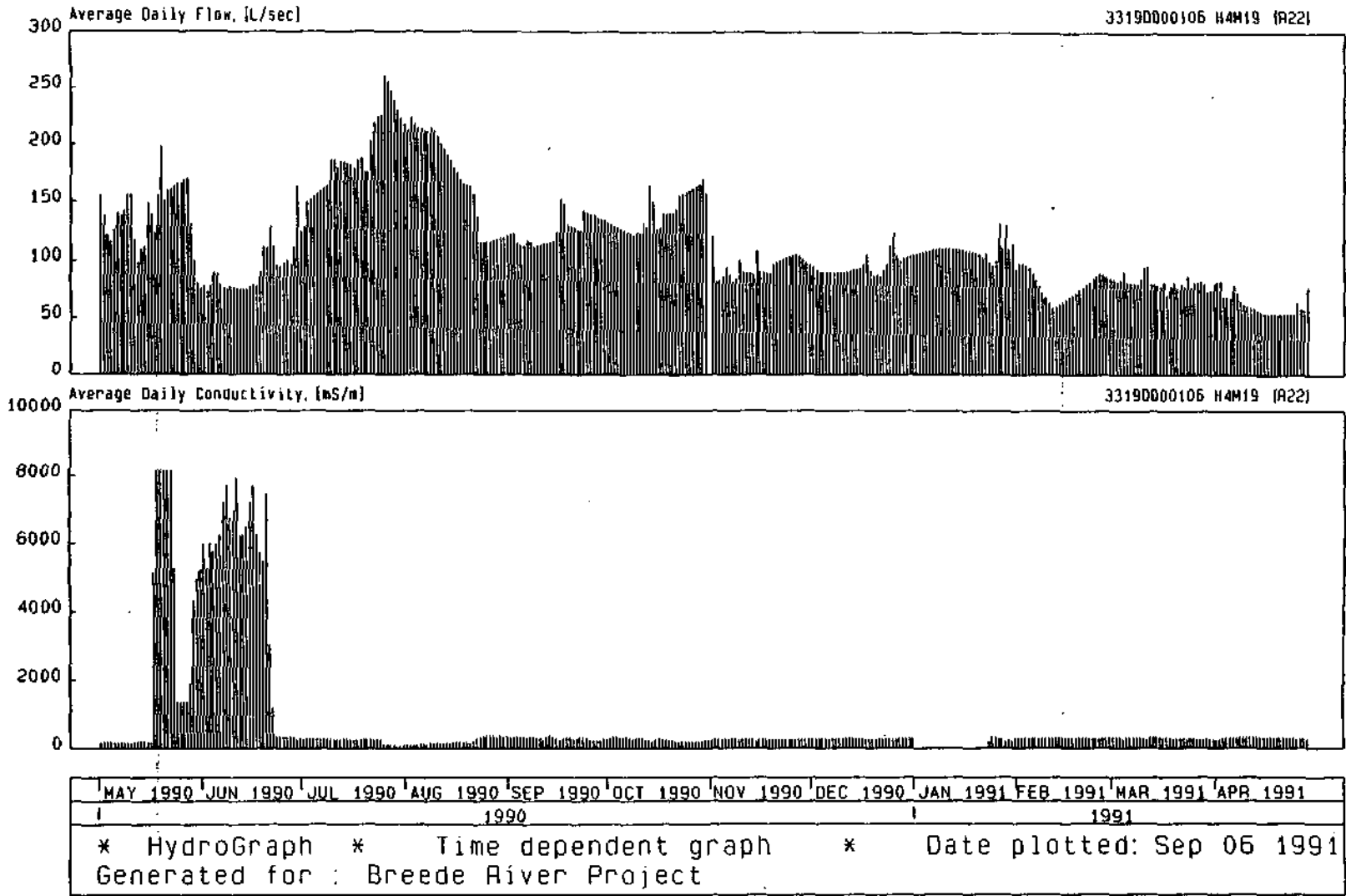

Figure 3.3: Mean daily flow and conductivity measured at H4H018 between May 1990 and April 1991.

Figure 3.4: Mean daily flow and conductivity measured at H4H019 between May 1990 and April 1991.



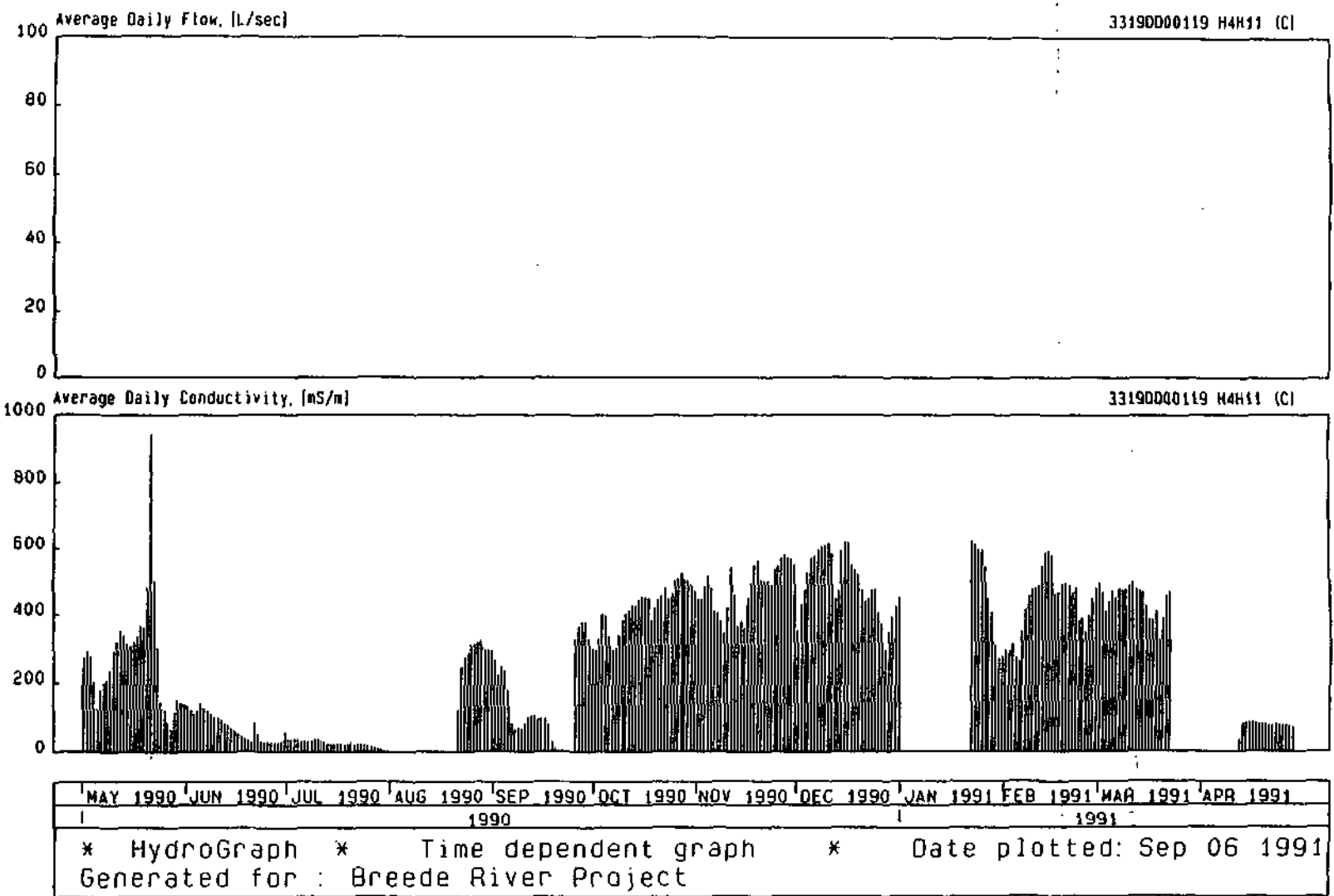
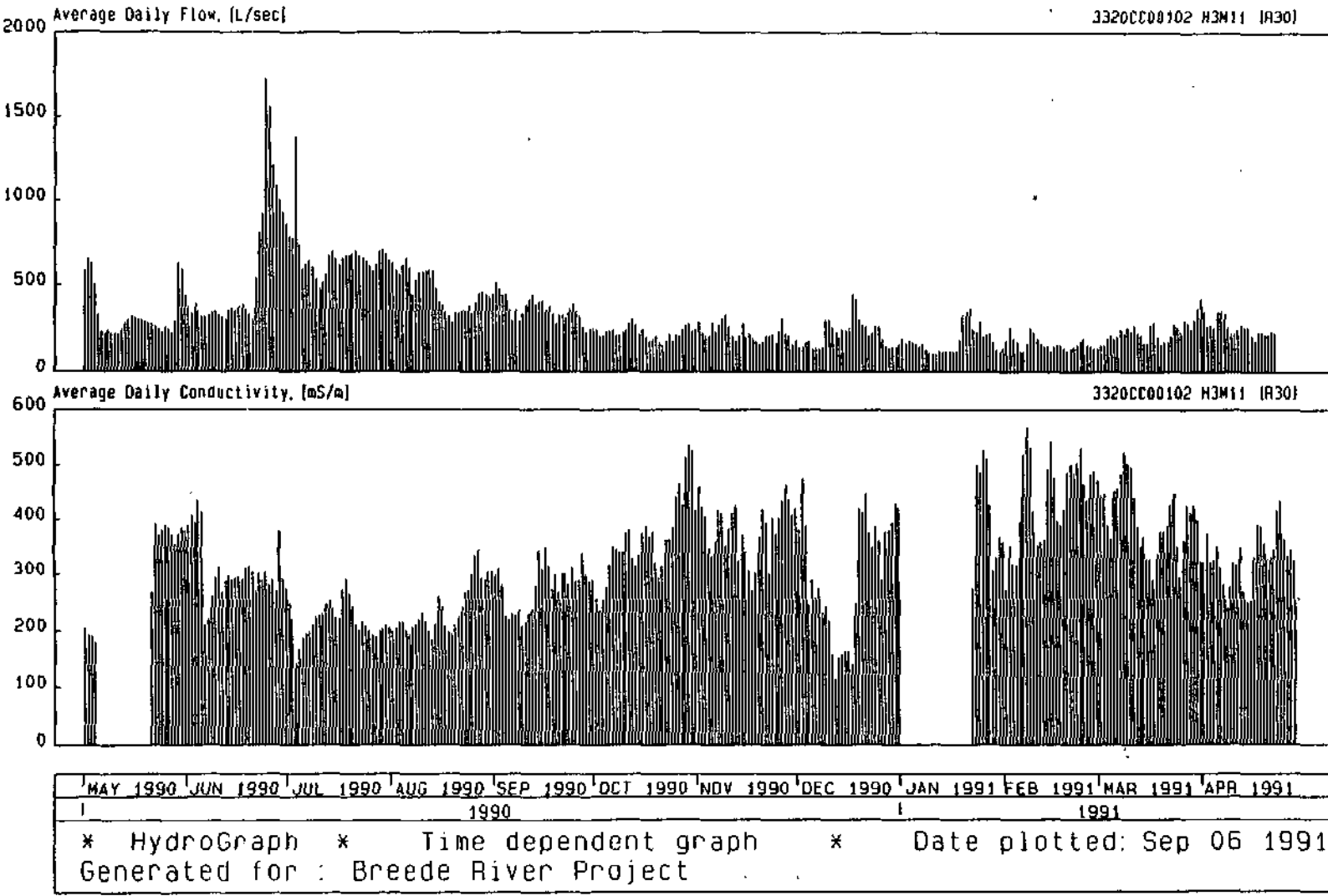

Figure 3.5: Mean daily flow and conductivity measured at H4H011 between May 1990 and April 1991.

Figure 3.6: Mean daily flow and conductivity measured at H3H011 between May 1990 and April 1991.



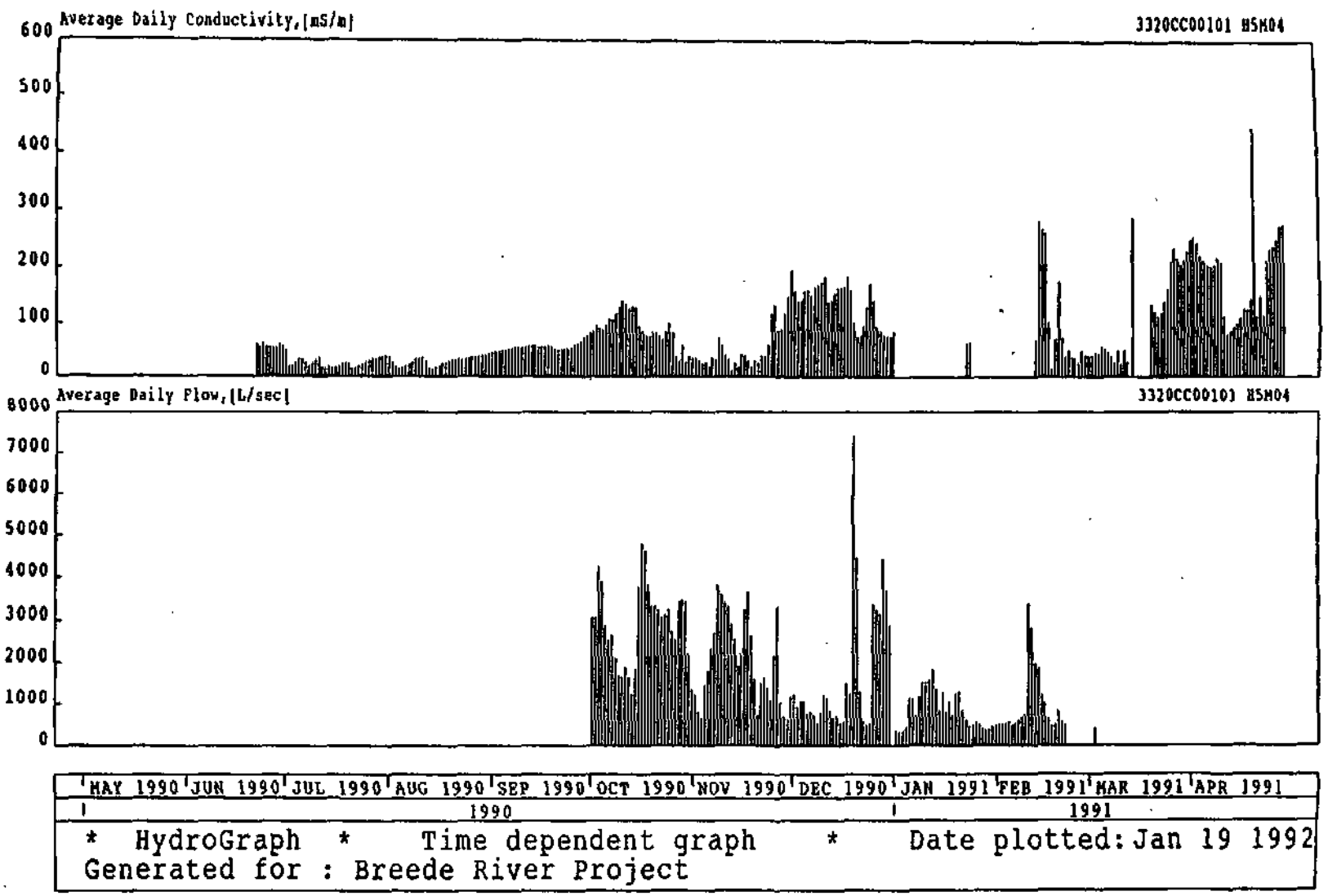

Figure 3.7: Mean daily flow and conductivity measured at H5H004 between May 1990 and April 1991.

3.2.2 RAINFALL

Rainfall data from two stations inside and one station outside the project area, are available for the period May 1990 to April 1991. The annual precipitation for the stations McGregor and Robertson is nearly identical, while Worcester had approximately 15% more rain. Monthly means for all three stations follow the same trend, but differences between stations within the area of up to approximately 30 mm in June, indicate that individual rainfall events can be quite localised.

**MONTHLY RAINFALL BETWEEN MAY 1990 AND APRIL 1991
at three stations in the
BREDE RIVER VALLEY**

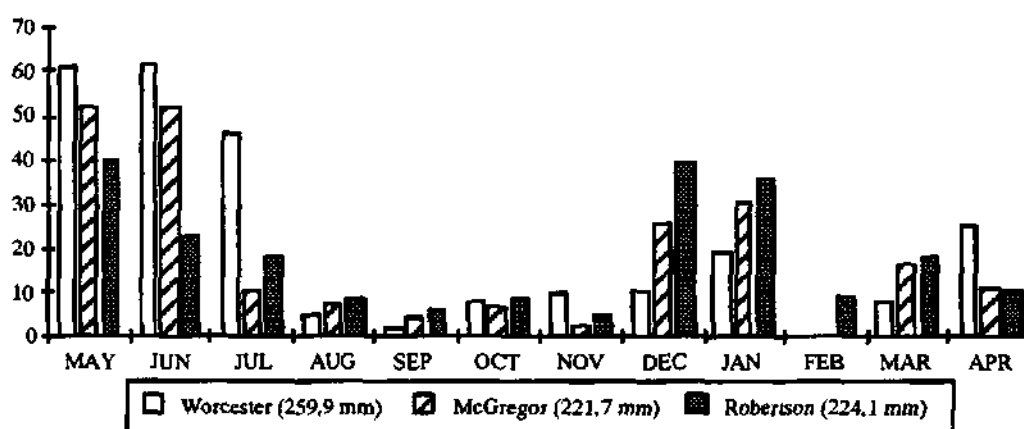

Figure 3.8: Monthly rainfall for three rainfall stations for the period May 1990 to April 1991.

Daily rainfall data for the three stations are displayed in Figures 3.9 to 3.11. During the period under consideration, maximum rainfall did not exceed 35 mm in Worcester and Robertson and 30 mm in McGregor. The number of days on which rainfall was recorded were 36, 64 and 42 respectively. During the same period, daily rainfall exceeded 10 mm on eight days in Worcester and McGregor and on six days in Robertson.

Rainfall is much higher in the mountains and run-off in the valleys is mainly caused by rainfall there. Generally, it can be assumed that major rainfall events in the mountains occur during the same period as in the valley. The size of floods, however, cannot necessarily be correlated with the amount of rain recorded at the rainfall stations.

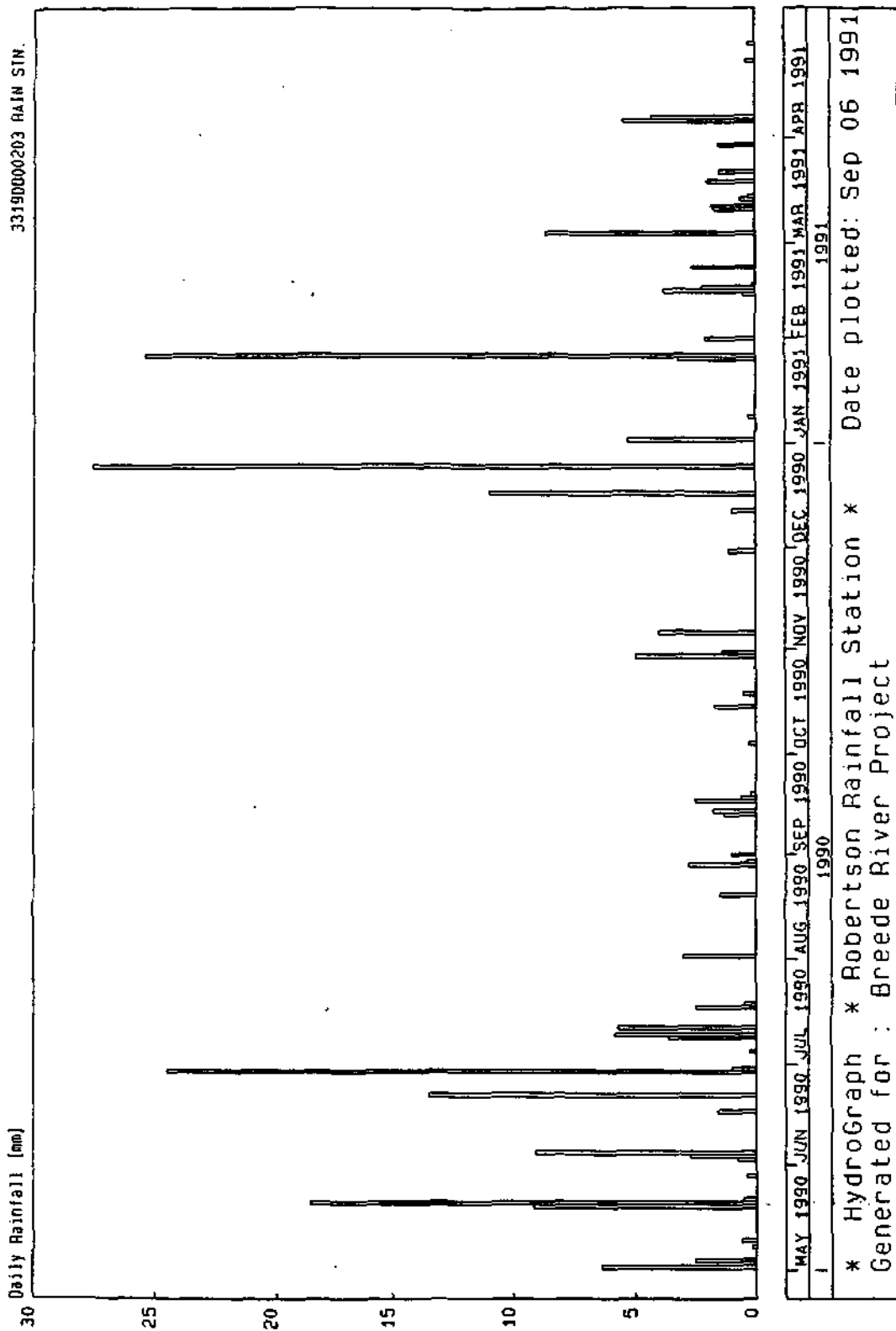

Figure 3.9: Rainfall recorded at the Robertson Rainfall Station for the period May 1990 to April 1991.

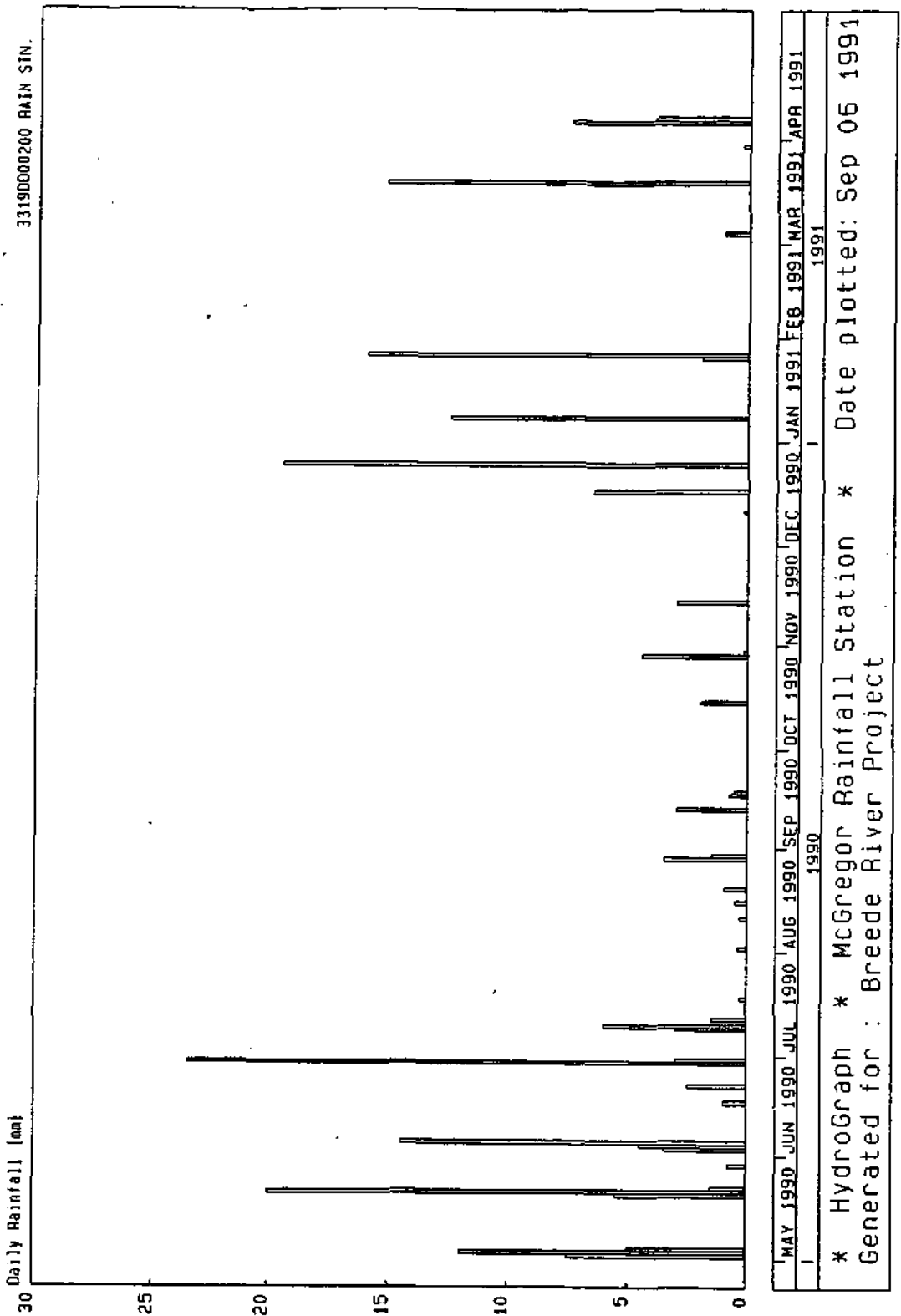

Figure 3.10: Rainfall recorded at the McGregor Rainfall Station for the period May 1990 to April 1991.

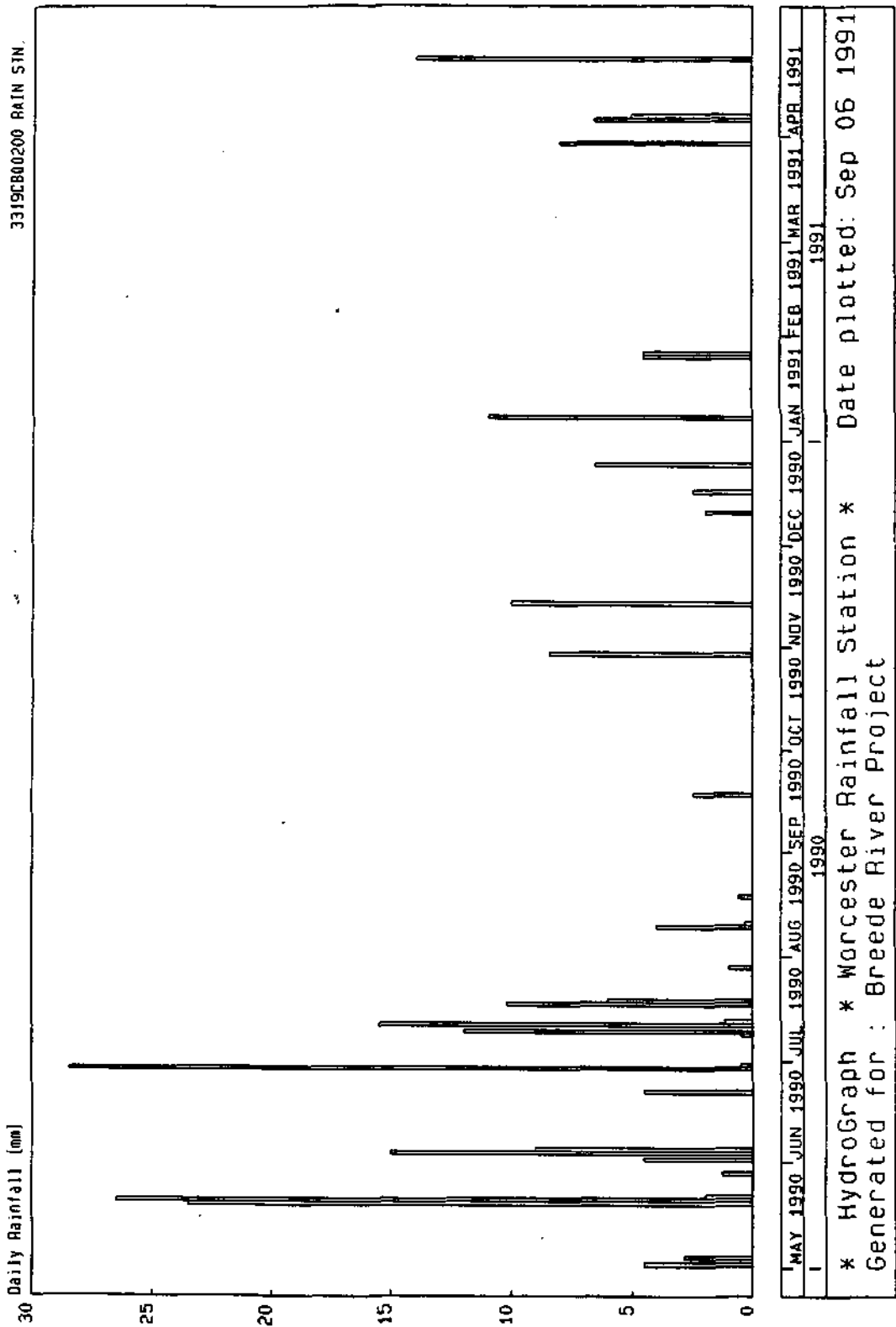

Figure 3.11: Rainfall recorded at the Worcester Rainfall Station for the period May 1990 to April 1991.

3.2.3 GROUND WATER

Seventy-three test boreholes were drilled in 1987 in the *Robertson and Vink River* areas (Jolly, 1990). They carry G-numbers between G33570 and G33611 allocated by the Directorate of Geohydrology. Their construction data are stored in the NGDB and are shown for some of the holes on graphs in Appendix 2.

Pumping tests were carried out in 1988 on three holes. These data are stored in the HydroCom data base. The pumping test evaluation is discussed later in the report.

Water levels, temperature and electrical conductivity were measured by HRI on a weekly basis since October 1988. From April 1990 onwards, 56 of the exploration holes were monitored by Murray, Biesenbach and Badenhorst.

WATER LEVELS

During the project period, the recorded water levels varied between 0,0 and 34,4 m with a mean depth to the water level of approximately 6 m. In the majority of the cases, maximum variations were about 1 m. Neither holes with a shallow nor those with a deep water level show a consistent trend. There is an indication that slightly deeper water levels occurred in the winter months of 1990 (see Figure 3.12) when the mean water levels were 0,25 to 0,30 m deeper than during the summer months.

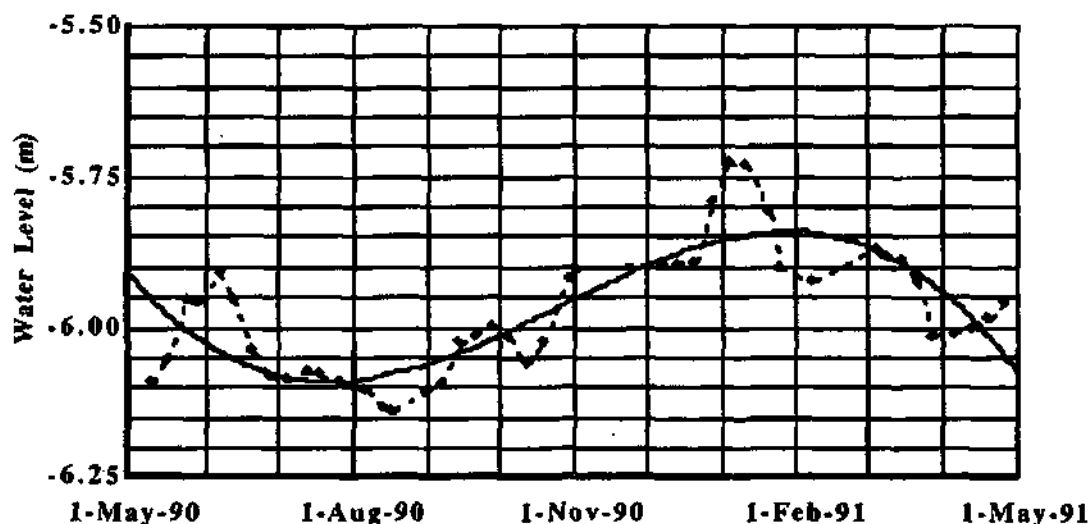

Figure 3.12: Mean water level of all monitored test holes in the Vink- and Robertson area (moving average; a third order polynomial is fitted to the data).

Water-level gradients in the two areas are about 1:70 to 1:120 (cf. Jolly, 1990, Figures 6 and 7). The estimated mean distance between the boreholes and the Breede River is more than 1 km. Changes in the gradient, caused by the water-level variations of about 0,3 m, are less than 2,0 to 3,5 percent.

Based on the observation that water-level variations in the individual test holes are in the order of 0,3 m, it is concluded that the water-level gradient between the holes and the Breede River does not change noticeably. The ground-water flow rate throughout the year can therefore be considered as comparatively constant.

ELECTRICAL CONDUCTIVITY

The electrical conductivity (EC) of water struck during drilling was measured by the Department of Water Affairs and Forestry and was reported by Jolly (Appendix B in Jolly, 1990). The EC has also been logged in a number of the exploration holes. These EC logs have been made available and are, with a few exceptions, included in the HydroCom data base. The logged EC values do not correspond with the measured EC data¹. The graphed data show, however, the relative changes of the conductivity of the ground water with depth and have, therefore, been included. They appear in Appendix 2. On the majority of the graphs, one can see that

- i) the conductivity of the water for the first metre or two² is, sometimes considerably, higher than below and
- ii) in about half of the cases the EC values vary considerably with depth.

The HRI has measured the electrical conductivity in the exploration holes on a weekly basis since 1987. As from April 1990, MBB has taken over that task. A WTW EC meter with automatic temperature correction was used for this purpose. The EC- and temperature readings of the instrument were checked in five different solutions³ before each measurement trip. Then the instrument was cleaned and checked again. Between April and October 1990, standard solutions prepared by the HRI were used. In October, a pharmacy in Robertson made up new standard solutions.

In the field, the samples for EC- and temperature measurement were bailed from just below the water level.

From the aforesaid, it is concluded that the EC values of samples taken from the water surface have a higher than mean conductivity. Apparently, there is a certain horizontal movement of the ground water. The flow velocity may, however, differ for the different strata. To obtain representative mean salt transport values, either the velocities of the flow in

¹ The formula $\text{mS/m} = 0,01 \text{ CPS}$ given by the manufacturer of the logger has been used to convert the data but there are apparently problems with this conversion.

² cf. Table 3.3 (min/mean/max WL & EC)

³ Solution A: 100 ml solution C/1000 ml H₂O (dist.), EC = 147 $\mu\text{S/cm}$ at 25°C
 Solution B: 500 mg NaCl/1000 ml H₂O (dist.), EC = 1015 $\mu\text{S/cm}$ at 25°C
 Solution C: 0,744 g KCl/1000 ml H₂O (dist.), EC = 1409 $\mu\text{S/cm}$ at 25°C
 Solution D: 7,4365 g KCl/1000 ml H₂O (dist.), EC = 12,86 mS/cm at 25°C
 Solution Dx: 3,7182 g KCl/1000 ml H₂O (dist.), EC = 6,43 mS/cm at 25°C.

Table 3.4: Water-level and electrical conductivity statistics of exploration boreholes. EC values are wrongly calibrated.

Map number	Recs	Min-WL	Max	Mean	Std.dev	Min.EC	Max.EC	Mean	Std.d.	St/M	Max/Min
G33607	51	4,01	4,49	4,22	0,13	60,0	142,0	124,2	24,4	0,20	2,4
G33573A	51	2,75	3,95	3,01	0,17	70,0	170,0	143,2	27,7	0,19	2,4
G33608	51	1,82	2,95	2,06	0,21	74,0	197,0	163,1	35,3	0,22	2,7
G33598	51	2,19	3,30	3,02	0,17	92,0	261,0	208,8	48,2	0,23	2,8
G33592A	51	2,01	2,65	2,16	0,12	24,0	66,0	51,8	11,6	0,22	2,8
G33572	51	1,49	2,71	2,00	0,24	105,0	310,0	246,6	58,6	0,24	3,0
G33578	51	7,32	8,85	7,86	0,36	73,0	220,0	135,8	33,2	0,24	3,0
G33592	51	2,03	5,50	2,43	0,47	33,0	98,0	71,2	17,3	0,24	3,0
G33606	51	2,07	3,02	2,66	0,16	60,0	178,0	138,9	33,4	0,24	3,0
G33575	33	3,02	4,07	3,65	0,34	156,0	515,0	382,3	122,7	0,32	3,3
G33580	51	6,72	8,08	7,43	0,39	87,0	283,0	216,2	54,1	0,25	3,3
G33602	51	4,06	6,30	4,60	0,42	195,0	640,0	484,0	128,3	0,27	3,3
G33609	50	2,06	2,89	2,64	0,20	95,0	314,0	241,5	58,0	0,24	3,3
G33610	51	2,06	3,10	2,56	0,24	93,0	310,0	209,6	55,7	0,27	3,3
G33576A	50	0,00	0,80	0,53	0,20	119,0	389,0	297,1	76,6	0,26	3,3
G33573	51	2,40	3,40	3,04	0,17	181,0	629,0	487,9	132,0	0,27	3,5
G33611	51	1,90	2,95	2,09	0,22	99,0	350,0	239,6	66,3	0,28	3,5
G33570	51	14,06	15,96	14,74	0,33	197,0	758,0	557,3	165,5	0,30	3,8
G33593	51	3,00	3,85	3,20	0,17	187,0	718,0	524,1	156,2	0,30	3,8
G33605	51	2,30	3,38	3,00	0,15	109,0	423,0	301,6	84,7	0,28	3,9
G33572A	51	1,05	2,42	1,75	0,27	151,0	589,0	439,7	130,4	0,30	3,9
G33584A	51	1,26	1,70	1,43	0,11	172,0	665,0	487,2	141,9	0,29	3,9
G33596A	51	0,61	2,57	1,04	0,26	170,0	671,0	501,5	152,6	0,30	3,9
G33584C	51	1,20	1,62	1,36	0,11	136,0	543,0	318,6	80,5	0,25	4,0
G33576	50	1,01	2,04	1,53	0,23	163,0	672,0	483,2	149,7	0,31	4,1
G33601	51	0,75	1,90	1,19	0,29	165,0	682,0	507,5	150,8	0,30	4,1
G33590A	51	2,07	3,82	3,05	0,42	20,0	82,0	64,2	16,0	0,25	4,1
G33591B	50	2,06	3,12	2,71	0,24	174,0	724,0	535,3	168,2	0,31	4,2
G33600	51	4,90	6,40	5,47	0,37	95,0	406,0	319,1	86,1	0,27	4,3
G33603	51	11,80	13,03	12,31	0,28	145,0	630,0	476,7	141,2	0,30	4,3
G33589	51	9,60	12,77	10,31	0,52	157,0	733,0	533,7	171,2	0,32	4,7
G33596	51	0,10	1,17	0,85	0,15	201,0	973,0	669,7	219,9	0,33	4,8
G33584	51	2,02	2,47	2,17	0,08	229,0	1181,0	817,0	287,2	0,35	5,2
G33583	51	5,20	10,57	9,77	0,78	273,0	1606,0	1062,8	405,5	0,38	5,9
G33574A	50	2,30	3,95	3,21	0,21	169,0	994,0	650,6	248,6	0,38	5,9
G33574	51	3,06	4,09	3,59	0,21	219,0	1345,0	868,2	345,7	0,40	6,1
G33595	51	2,04	3,30	2,80	0,30	220,0	1380,0	919,7	358,1	0,39	6,3
G33590	51	2,90	5,75	4,17	0,42	21,0	136,0	90,1	36,4	0,40	6,5
G33586	51	4,03	4,69	4,42	0,18	228,0	1520,0	975,9	394,3	0,40	6,7
G33577	50	6,79	7,95	7,16	0,20	209,0	1458,0	971,7	396,0	0,41	7,0
G33579	51	4,75	6,98	5,85	0,46	255,0	1886,0	1249,2	509,5	0,41	7,4
G33599	51	2,04	2,95	2,46	0,27	212,0	1654,0	873,2	396,4	0,45	7,8
G33594	51	6,03	9,60	9,08	0,49	181,0	1500,0	511,6	198,5	0,39	8,3
G33583A	51	6,02	10,80	9,57	1,03	241,0	2120,0	1261,0	585,3	0,46	8,8
G33571A	50	24,10	26,03	25,20	0,29	236,0	2370,0	1308,2	667,1	0,51	10,0
G33591A	50	2,05	3,00	2,68	0,25	28,0	281,0	111,9	65,3	0,58	10,0
G33588	51	9,85	13,02	11,79	0,83	197,0	2170,0	1109,6	501,8	0,45	11,0
G33597X	51	2,31	4,90	3,11	0,32	195,0	2140,0	1259,1	605,9	0,48	11,0
G33582	51	7,05	7,97	7,43	0,30	254,0	2890,0	1610,9	793,8	0,49	11,4
G33591	51	2,70	4,04	3,67	0,27	31,0	406,0	190,7	122,9	0,64	13,1
G33581	51	18,99	19,95	19,18	0,20	229,0	3260,0	1661,0	939,3	0,57	14,2
G33587	51	29,05	32,70	31,38	0,70	214,0	3120,0	1468,3	868,6	0,59	14,6
G33575A	33	2,06	3,49	3,04	0,37	10,0	225,0	32,5	51,0	1,57	22,5
G33600C	51	5,60	6,90	6,22	0,25	70,0	2160,0	256,2	275,8	1,08	30,9
G33585A	51	32,04	32,95	32,59	0,26	3,0	2240,0	1199,5	636,4	0,53	746,0
G33574C	51	2,65	3,10	2,79	0,10	1,0	768,0	523,6	195,6	0,37	768,0

RECORDS	MIN-WL	MAX	MEAN	STD.D.	MIN.EC	MAX.EC	MEAN	STD.D.	STD/M
2812	0,00	32,95	5,98	6,82	1,0	3260,0	567,8	542,0	0,96

the different strata must be determined⁴ or boreholes must be pumped for a sufficient time, i.e., until the EC of the pumped water stabilises, before a reading is taken.

A considerable variation in the conductivity of the water samples from the different holes was observed. Mean values for the individual holes varied between 33 mS/m (G33575A) and 1661 mS/m (G33581). Without exception, the values measured in April 1991 were lower than those observed one year earlier. In most holes, a relative minimum occurred in August and a relative maximum between October 1990 and January 1991. This is also evident from Figure 3.13 in which, similar to the water-level graph, moving averages of the mean conductivity measurements are plotted.

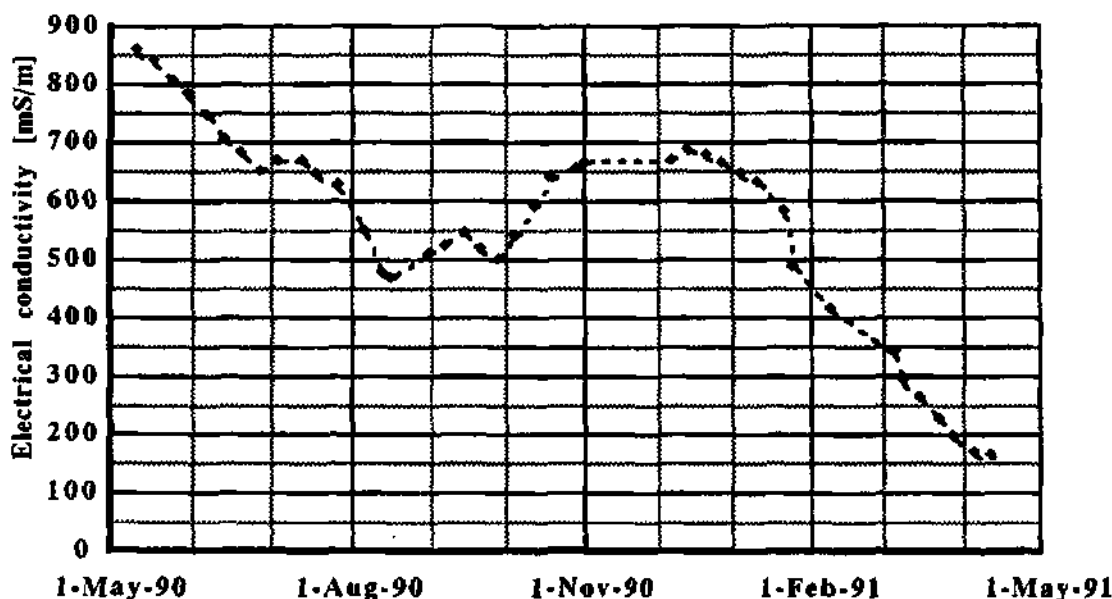

Figure 3.13: Sample of wrongly calibrated data. Mean conductivity determined in all monitored G-numbered holes in the Vink- and Robertson area (moving average).

The factor by which the measured electrical conductivities decreased during the year varied between 2,4 and approximately 20. A few higher Max/Min-ratios in Table 3.4 are attributed to faulty readings. The mean conductivity decreased by a factor of 5.

Figure 3.14 shows the variations of the instrument readings for the five different solutions. It is evident from this figure that there is a considerable drift of the measurements, generally from higher to lower values. The sudden change in October is ascribed to the use of a new standard solution. Statistical evaluation of the control measurements, shown in Table 3.5, reveals (i) noticeable deviations of the mean values from the standard values (cf. footnote on page 33) and (ii) a relation of the maximum vs. minimum measurements of between 2,1 and

⁴ Packer tests or tracer dilution techniques could be used for this purpose.

3,8 with an average of $\pm 2,9$. As the general trend of the control measurements is similar to the trend of the EC observations in the boreholes, it must be concluded that the measured decrease of the ground water can largely be attributed to a drift in the instrument reading.



Figure 3.14: Electrical conductivity measurements in standard solutions A, B, C, D and Dx during the period 3 May 1990 to 22 April 1991.

Table 3.5: Statistical evaluation of EC control measurements.

Electrical conductivity [$\mu\text{S}/\text{cm}$]	Solution A	Solution B	Solution C	Solution D	Solution Dx
Minimum value (after cleaning)	172	724	603	3880	2610
Maximum value (after cleaning)	474	1993	1491	13440	6940
Mean (after cleaning)	299	1255	1251	9540	5550
Max/Min (after cleaning)	2,8	2,8	2,5	3,4	2,7
Minimum value (before cleaning)	164	648	552	3560	2450
Maximum value (before cleaning)	462	1991	1477	13640	6810
Mean (before cleaning)	300	1210	1197	9040	5280
Max/Min (before cleaning)	2,8	3,1	2,7	3,8	2,8

Prof. J.H. Moolman¹ from the University of Stellenbosch investigated the matter and concluded that (i) field measurements taken with this EC meter are underestimating the real conductivity, readings can, however, be adjusted mathematically and that (ii) the sensitivity of the meter may have decreased with time. Earlier measurement may therefore be more accurate than later ones.

¹ Letter to Dr. A. Görgens of Ninham Shand, dated 15 January 1992.

Even if the readings are adjusted, it cannot be guaranteed that the corrected values reflect the true conductivity at the time of measurement. One has, furthermore, to remember that the true conductivities measured just below the water level of boreholes which were not pumped before the measurements were made, will most probably not reflect the mean conductivity of the water in the aquifer around the borehole.

No further attempt was therefore made to draw any conclusions from these EC data. It is essential that in any future investigations (i) instruments remain properly calibrated and measurements are verified on a regular basis and (ii) suitable sampling methods are applied to ensure that the measurements reflect as good as possible the property which is investigated.¹

3.2.4 CHEMICAL ANALYSES

Samples for chemical analysis of 250 ml were filtered immediately after collection to remove impurities which might change the chemical composition in the period between sampling and analysis. A 50 ml sample was acidified for analysis of cations. A separate filtered sample was collected for isotope analysis. The samples were analysed in the laboratory of the Institute for Ground-water Studies. For determination of cations, an ICP (Inductive Coupled Plasma) was used. Anions were determined with an IC (Ion Chromatography). A Specific Ion Electrode was used for fluoride and potentiometric titration for alkalinity determination.

In the beginning, complete scans were done to identify any trace elements that might be present. On the basis of these initial scans, it was decided to analyse quantitatively for the following ions: Na, K, Ca, Mg, alkalinity, Cl, SO₄, F, NO₃, NO₂, Al, Ba, B, Br, Cu, Fe, Mn, Si, Sr and Zn.

A total of 606 samples was analysed by IGS. These analyses (together with those done by the HRI) are listed in Appendix 5 and 6. In a few cases, analyses did not balance. Where the electrical conductivity was low, a difference of one mg/l can result in the anion/cation balance exceeding the 5% limit. Where this was not the case, analyses were repeated if there was a sufficient quantity of the sample left. In many cases, the analyses could be corrected. A number of analyses still exceeded the 5% limit.

GROUND WATER

A number of hydrochemical diagrams allow to display and classify water analyses. Five types of diagrams, the Piper-, Durov-, Schoeller-, SAR- and expanded Durov diagram have been used. These diagrams are explained in Appendix 16. The hydrochemical diagrams of

¹ Regarding the sampling of ground water the reader is referred to: J.M.C. Weaver: Groundwater sampling. WRC Project No 339, TT 54/92, Pretoria 1992

the different formations discussed are found in Appendices 7 to 12. These appendices also contain a list of the sites belonging to each group. A Piper-, a Durov-, a Schoeller- and a Sodium-adsorption diagram all show analyses of a group and separately for each sampling point. For each group, there is also an expanded Durov diagram included.

Malmesbury Group

Fifteen boreholes deemed to belong to the Malmesbury Group were sampled on a regular basis. The different geohydrochemical graphs are summarised as follows:

Piper diagram:

The majority of the analyses plot in the upper half of the quadrilinear diagram; VR01 being the major exception.

Durov diagram:

pH: 6- 8
EC: 4 - 300 mS/m

Sodium adsorption ratio diagram:

Irrigation classification: $C_1S_1 - C_3S_1$
with a few exceptions.

Schoeller diagram:

Calcium is often slightly higher than magnesium and chlorine the predominant anion.

Expanded Durov diagram:

Magnesium carbonate, -chloride and -sulphate prevail. (Na+K)Cl.

Table Mountain Group

Nineteen sites sampled on a regular basis were identified as Table Mountain Sandstone. The following deductions can be made from the geohydrochemical graphs:

Piper diagram:

The majority of the analyses have plotting positions near the sea-water point. Noticeable exceptions are ZN03, LE01, CD1A and AF. Their analyses plot near the recharge point. These sites are nearer to the middle of the valley and either a local recharge component or a mixture with water from other aquifers must be considered.

Durov diagram:

pH: 4 - 8
EC: 5 - 300 mS/m

Sodium adsorption ratio diagram:

Irrigation classification: $C_1S_1 - C_3S_2$
with the majority in classes C_1S_1 and C_1S_2 .

Schoeller diagram:

With a few exceptions Ca^{++} and HCO_3^- are least represented. The Ca/Mg relation is varying; $\text{Na} > \text{Mg}$ and $\text{Cl} > \text{SO}_4$; where SO_4 is high, HCO_3 is low and vice versa.

Expanded Durov diagram:

The predominant salts change from $\text{Mg}(\text{HCO}_3)_2$ or MgCO_3 to NaCl.

Bokkeveld Group

Water samples from 15 boreholes and from one fountain classified as Bokkeveld were taken at quarterly intervals. In addition, one or more chemical analyses are available from 27 of the exploration holes.

Piper diagram:

The majority of the points plot, like the TMS, near the sea-water point. However, there are also a number of analyses that plot nearer to the top of the quadrilinear area (DD125, DD1606) and others near the bottom corner (e.g. DD22 and DD24). Near the recharge area plots DD33.

Durov diagram:

pH (with one exception): 6 - 9
EC: 15 - 5 000 mS/m

Sodium adsorption ratio diagram:

Irrigation classification: $\text{C}_1\text{S}_1 - \gg \text{C}_4\text{S}_4$
with the majority in classes C_3S_2 and above.

Schoeller diagram:

Sodium and chloride are the predominant ions. Low TDS samples have very low sulphate concentrations. Calcium and magnesium are variable.

Expanded Durov diagram:

The predominant salt is NaCl.

Witteberg Group

Water samples from two boreholes, classified as Witteberg, were taken outside the study area at the beginning of the project and two samples from a borehole and a well within the area at quarterly intervals.

Piper diagram:

All analyses plot slightly left of and just above the centre of the quadrilinear diagram with little sulphate and approximately equal amounts of chloride and carbonate.

Durov diagram:

pH (approximately): 7 - 8
EC: 30 - 100 mS/m

Sodium adsorption ratio diagram:

Irrigation classification: C₂S₁
with one sample C₃S₁.

Schoeller diagram:

Sodium, chloride and bicarbonate are equally concentrated. Calcium and magnesium are lower, but also equal.

Enon Formation

Water samples from 17 boreholes were classified as Enon. One sample was taken at quarterly intervals. In addition, one or more chemical analyses are available from 16 of the exploration holes.

Piper diagram:

The majority of the points plot near the sea-water point. However, there are also a number of analyses that plot slightly further left.

Durov diagram:

pH (in a wide range): 3 - 9
EC (1 site about 25): 200 - 3 000 mS/m

Sodium adsorption ratio diagram:

Irrigation classification: C₁S₁ - » C₄S₄
with the majority in classes C₄S₄ and above.

Schoeller diagram:

Sodium and chloride are the predominant ions. Sulphate is scattered over a wide range. Calcium and magnesium are variable.

Expanded Durov diagram:

All samples plot in the NaCl field.

The results of the chemical analyses are consolidated in Table 3.6 which shows the number of analyses from each source and the mean and standard deviation for all parameters determined. The average values are repeated in Table 3.7. This table is sorted according to sources in the main channel and canals, the tributaries and the aquifers. The maximum values for each parameter and source are printed in bold and the minimum in italics.

Enon is obviously, on average, the highest mineralised source. It is closely followed by the samples from the Bokkeveld Group. However, the variation in these two aquifers is considerable: the standard deviation of the various parameters for Bokkeveld is of the same order as the mean, but for the Enon it is slightly lower. On the other hand, it has to be taken

	pH	EC	TDS	Na	K	Ca	Mg	M.A.M.S	SO ₄	F	NO ₃ -N	PO ₄ -N	Fe	Mn	PO ₄	Si	Zn	Temp.	Source									
		(mS/cm)	(mg/L)	(mg/L)	(mg/L)	(mg/L)	(mg/L)	(mg/L)	(mg/L)	(mg/L)	(mg/L)	(mg/L)	(mg/L)	(mg/L)	(mg/L)	(mg/L)	(mg/L)	(mg/L)	(°C)									
Average	7.2	740	4947	1344	38.7	77	140	205	2815	185	2.3	0.4	0.9	0.083	0.280	378	7.7175	0.208	4.970	1.4	1.0270	0.55	20.3	Enon				
Std. dev.	1.3	4	4	4.0	5	3	4	7	3.8	2.3	5.9	1.269	4575	275	4.022	981	14.4418	138	2.040	5.8	9.8756	847	7	Enon				
Number	49	49	49	49	49	49	49	44	49	49	49	49	49	49	49	49	49	49	49	49	49	49	49	49	Enon			
Average	7.2	81	454	75	0.9	39	19	114	111	35	0.3	0.7	0.0	0.083	0.210	340	0.305	0.020	4.970	1.4	0.3794	0.58	19.0	Witberg				
Std. dev.	1.1	1	1	1.7	1	1	1	1	1.2	1.5	5.3	1.003	4732	298	2.281	0.051	5.884	3.341	1.4	1.9122	357	1.6	4	Witberg				
Number	8	8	8	8	8	8	8	8	8	8	8	8	8	8	8	8	8	8	8	8	8	8	8	8	Witberg			
Average	7.5	232	1698	485	10.5	48	85	120	814	107	1.0	0.4	0.089	0.400	241	2.485	0.222	0.280	0.132	1.137	4.1	0.5893	0.63	21.1	Bokkeveld			
Std. dev.	1.1	3	3	3.3	3	3	3	2	4	2.8	2.6	4.0	1.819	3804	828	3.790	451	4.820	5.102	4.084	4.3	3.0252	942	2.9	Bokkeveld			
Number	222	222	222	222	222	222	222	221	222	222	221	222	221	222	222	222	222	222	222	222	222	222	222	222	222	Bokkeveld		
Average	6.1	17	130	24	3.7	7	4	19	36	10	0.4	0.1	0.089	0.370	0.14	0.131	0.021	0.188	0.087	0.048	10.9	0.0532	0.74	22.2	TMS			
Std. dev.	1.1	2	2	2.2	2	2	2	2	2	2	1.9	1.5	2.7	1.315	2871	292	2.918	2.022	3.581	4.750	2.889	1.6	3.3412	622	3.3	TMS		
Number	74	74	74	74	74	74	74	72	74	72	72	72	72	72	72	72	72	72	72	72	72	72	72	72	72	TMS		
Average	7.3	62	485	74	2.0	39	15	125	113	39	0.5	0.4	0.0	0.083	0.180	332	0.414	0.022	0.508	0.118	0.818	7.4	0.3528	0.98	16.0	Malmesbury		
Std. dev.	1.1	3	3	3.3	3	3	3	2	3	3	1.9	2.8	3.1	1.251	2172	371	2.941	513	4.987	3.140	71.525	1.8	4.9174	0.94	2.8	Malmesbury		
Number	59	59	59	59	59	59	59	57	59	57	59	57	59	57	59	57	59	57	59	57	59	57	59	57	59	Malmesbury		
Average	6.0	5	32	6	0.4	3	1	6	13	3	0.5	0.3	0	0.103	0.230	0.13	0.029	0.021	0.325	0.025	0.020	0.4	0.0235	0.05	16.0	River (B.V.-Dam)		
Std. dev.	1.1	1	1	1	2.6	1	1	1	1	2	2.3	1.1	1	1.259	8861	0.00	1.228	1.113	1.757	1.000	1	1.6	2.0552	3.98	1	River (B.V.-Dam)		
Number	6	6	6	6	6	6	6	6	6	6	6	6	6	6	6	6	6	6	6	6	6	6	6	6	6	River (B.V.-Dam)		
Average	6.3	15	88	18	1.1	7	5	18	30	12	0.3	0.5	0	0.089	0.130	0.13	0.083	0.029	0.457	0.041	0.000	1.2	0.0450	0.02	15.4	River: Braeds A		
Std. dev.	1.1	1	1	1.7	1	1	1	1	1	2	2.3	3.1	1	1.782	4881	0.00	1.508	0.049	1.434	2.340	1.9	1.4752	2.69	1	1	River: Braeds A		
Number	6	6	6	6	6	6	6	6	6	5	4	5	6	6	6	6	6	6	6	6	6	6	6	6	6	1	River: Braeds A	
Average	6.4	21	113	21	1.3	5	9	13	40	14	0.1	0.2	0.3	0.089	0.180	0.48	0.274	0.023	0.516	0.029	0.040	3.4	0.1418	0.04	16.3	River: La Chess		
Std. dev.	1.1	1	2	2	1.5	2	2	2	2	2	1.7	2.2	3.8	1.210	6812	0.03	2.941	2.59	1.606	1.355	1	2.1	2.8353	0.00	5.1	River: La Chess		
Number	117	117	117	117	117	117	117	117	117	117	98	77	2	12	14	13	10	12	12	12	12	1	115	14	12	103	River: La Chess	
Average	7.9	384	2343	592	12.0	89	170	229	1007	270	9.9	0.5	0.2	0.089	0.380	0.18	2.504	0.020	0.119	0.046	29.000	4.8	1.1988	4.08	17.0	River: Poos		
Std. dev.	1.1	2	2	2.0	2	2	2	2	2	2	2.0	2.3	2.0	1.000	8983	0.95	2.718	0.015	3.548	2.428	1	1.7	2.2362	1.78	4	River: Poos		
Number	119	119	119	119	119	119	119	119	119	119	119	119	119	119	119	119	119	119	119	119	119	119	119	119	119	119	119	River: Poos
Average	7.2	277	1501	391	3.8	117	84	195	789	230	1.1	0.4	0.3	0.083	0.250	0.13	2.125	0.020	0.088	0.030	0.020	5.8	0.9505	0.05	18.8	River: Vink		
Std. dev.	1.4	1	1	1	1.3	1	1	1	1	1	2.1	3.9	5.8	1.000	8783	0.80	2.345	0.041	2.523	1.753	1	1.3	2.2302	2.01	3.5	River: Vink		
Number	16	16	16	16	16	16	16	15	16	15	15	3	3	17	14	12	14	12	12	12	12	1	14	14	12	4	River: Vink	
Average	8.0	118	948	215	6.8	40	24	303	214	54	1.5	0.4	3.3	0.089	0.410	0.57	0.970	0.045	0.082	0.023	1.270	14.8	0.3855	0.60	10.8	River: Sand		
Std. dev.	1.0	2	2	2	2.2	2	2	2	2	2	2.0	1.4	1	1.138	4822	0.52	3.357	1.50	3.083	1.000	1	1.6	3.5822	5.42	8	River: Sand		
Number	10	10	10	10	10	10	10	10	10	10	10	10	10	10	10	10	10	10	10	10	10	10	10	10	10	10	River: Sand	
Average	7.3	35.2	265.6	48.1	1.5	24.1	9.9	83.4	84.8	25.5	0.4	0.4	0.5	0.1	0.0	0.3	0.0	0.1	0.0	0.1	0.0	5.1	0.2	0.0	18.0	River: Nels		
Std. dev.	1.1	1.9	1.7	1.5	1.9	1.7	1.7	1.7	1.7	1.9	1.5	1.8	1.8	1	1.0	1.8	2.3	2.4	1.1	4.2	2.1	1.3	2.3	1.5	1	1	River: Nels	
Number	6	6	6	6	6	6	6	6	6	6	6	6	6	6	6	6	6	6	6	6	6	6	6	6	6	6	1	River: Nels
Average	7.9	219	1789	438	7.5	103	82	350	827	145	1.4	0.3	0	0.083	0.380	0.18	2.085	0.023	0.061	0.078	1.540	13.1	0.9346	0.00	17.0	River: Hoops		
Std. dev.	1.0	1	1	1	1.2	1	1	1	1	1	2.2	2.4	1	1.000	2771	0.87	1.351	3.42	3.800	3.809	1	1.1	1.1272	4.80	4	4	River: Hoops	
Number	6	6	6	6	6	6	6	6	6	6	6	6	6	6	6	6	6	6	6	6	6	6	6	6	6	6	4	River: Hoops
Average	8.2	429	3371	877	14.3	101	128	350	1204	440	1.6	0.5	0.2	0.089	0.480	0.24	3.448	0.020	0.181	0.051	3	3.8	1.1859	0.08	22.7	River: Kalsans		
Std. dev.	1.0	2	2	1	1.3	1	1	1	1	1	1.9	1.6	1.2	1.330	2211	0.21	1.513	0.882	4.173	2.580	1	1.6	1.3584	5.72	9.5	2	River: Kalsans	
Number	13	13	13	13	13	13	13	13	13	13	12	2	2	11	11	11	11	11	11	11	11	11	11	11	11	11	2	River: Kalsans
Average	7.9	238	1858	482	8.7	62	73	249	861	217	1.0	0.8	0.1	0.083	0.330	0.51	2.088	0.023	0.064	0.027	1.190	6.6	0.8055	0.08	19.8	River: Voogds		
Std. dev.	1.1	1	1	1	1.5	1	1	1	1	1	1.9	2.1	1	1.083	3811	0.63	1.474	3.80	2.818	1.218	1	1.3	1.4222	8.17	1	1	River: Voogds	
Number	20	20	20	20	20	20	20	20	20	20	20	20	20	20	20	20	20	20	20	20	20	20	20	20	20	20	1	River: Voogds
Average	8.1	328	2028	484	8.3	71	92	280	825	232	0.7	0.5	0.1	0.083	0.470	0.58	2.088	0.021	0.111	0.041	0.447	4.1	0.7934	0.27	19.3	River: Kogm.		
Std. dev.	1.0	1	1	1	1.4	1	1	1	1	1	1.6	1.7	2.8	1.000	4332	0.65	2.016	1.196	3.063	2.375	5.740	1.7	1.6212	0.80	5.7	1	River: Kogm.	
Number	116	116	116	116	116	116	116	116	116	116	115	2	2	12	14	12	13	12	12	12	2	114	14	12	100	1	1	River: Kogm.
Average	7.1	83	338	78	2.5	14	15	42	130	40	0.2	0.3	0.7	0.089	0.280	0.39	0.780	0.023	0.277	0.031	0.030	1.4	0.3823	0.39	19.4	River: Secunda		
Std. dev.	1.1	2	2	2	2.0	2	2	2	2	2	1.9	2.2	6.8	1.193	6892	0.83	4.527	4.24	2.277	1.841	1	1.8	2.6551	4.39	5.8	1	River: Secunda	
Number	118	118	118	118	118	118	118	118	118	118	100	92	2	12	14	12	14	12	12	12	1	118	14	12	101	1	1	River: Secunda
Average	6.5	11	105	24	1.0	7	4	14	28	10	0.4	0.7	0	0.083	0.150	0.15	0.050	0.020	0.229	0.023	0.700	1.1	0.0898	0.63	19.0	River (Canal, LC)		
Std. dev.	1.1	2	2	2	2.1	2	2	2	2	2	3.1	2.4	1	1.278	5481	0.85	2.082	4.75	1.504	1.000	1	2.3	2.7703	1.48	4	1	River (Canal, LC)	
Number	11	11	11	11	11	11	11	11	11	11	10	11	1	9	9	8	4	8	9	9	9	9	9	9	9	9	1	River (Canal, LC)
Average	6.6	27	302	47	1.4	11	9	28	69	28	0.2	0.5	0.1	0.083	0.140	0.37	0.241	0.021	0.220	0.023	0.470	0.9	0.1059	0.48	19.0	River (Canal, RCB)		
Std. dev.	1.0	1	1	1	1.8	1	1	1	1	1	1.9	2.5	1	1.000	2121	0.21</												

Table 3.7: Mean temperature and logarithmic mean values of chemical variables of all analyses from the different sources.

pH	EC	TDS	Na	K	Ca	Mg	M.Alk	Cl	SO ₄	F	NO ₃ -N	NO ₂ -N	Al	Ba	S	Br	Cu	Fe	Mn	PO ₄	Si	Sr	Zn	Temp.	Ion-bal	Source
	mS/m	mg/L	mg/L	mg/L	mg/L	mg/L	mg/L	mg/L	mg/L	mg/L	mg/L	mg/L	mg/L	mg/L	mg/L	mg/L	mg/L	mg/L	mg/L	mg/L	mg/L	mg/L	mg/L	°C	%	
5,98	6	39	9	0,5	3	1	6	13	4	0,2	0,2	0,0	0,103	0,044	0,010	0,012	0,016	0,375	0,019	0,007	0,388	0,034	0,035	16,0	9,3	River (Dam)
6,27	16	100	20	1,2	7	5	16	31	13	0,3	0,5	0,0	0,048	0,014	0,009	0,065	0,014	0,480	0,027	0,030	1,400	0,048	0,028	15,4	3,8	River: Breede Dam
6,40	22	122	26	1,3	6	6	15	43	17	0,1	0,3	0,1	0,068	0,003	0,010	0,433	0,002	0,350	0,003	0,007	4,257	0,034	0,006	17,8	8,9	River: La Chass.
6,43	11	103	23	1,0	7	4	19	28	11	0,8	1,0	0,0	0,089	0,013	0,012	0,011	0,018	0,239	0,020	0,350	1,513	0,102	0,071		6,6	River (Canal LC)
6,79	28	206	49	1,7	11	10	29	68	27	0,2	0,7	0,0	0,080	0,011	0,031	0,121	0,016	0,227	0,019	0,235	1,167	0,081	0,045		5,2	River (Canal Rob)
6,94	42	296	68	1,9	15	13	40	105	40	0,2	0,6	0,0	0,080	0,017	0,062	0,251	0,024	0,299	0,026		1,963	0,151	0,035		2,3	River (Canal Ang.)
6,97	47	326	76	2,4	17	14	48	114	40	0,2	0,6	0,0	0,080	0,015	0,068	0,354	0,020	0,203	0,023	0,000	1,225	0,142	0,039	23,6	3,6	River (Canal Sand)
7,13	82	476	114	3,5	18	22	60	186	56	0,2	0,3	0,2	0,088	0,004	0,020	1,931	0,003	0,395	0,004	0,008	1,709	0,069	0,005	18,7	0,5	River: Secunda
7,48	295	1886	412	3,8	122	99	191	827	242	1,5	8,3	0,1	0,080	0,062	0,253	2,597	0,015	0,134	0,029	0,005	5,806	1,009	0,034	19,8	-1,2	River: Poesiesn.
7,91	447	2772	658	15,2	117	131	267	1198	319	0,8	0,7	0,0	0,080	0,008	0,044	3,275	0,002	0,216	0,006	5,800	5,393	0,160	0,006	16,6	-0,2	River: Vink
7,97	133	1070	247	10,7	43	27	366	238	61	1,9	0,5	0,3	0,086	0,035	0,516	3,451	0,368	0,100	0,020	0,635	15,638	1,609	0,021		0,4	River: Sand
7,29	41	315	53	1,8	27	11	94	74	28	0,4	0,5	0,1	0,080	0,022	0,058	0,383	0,021	0,393	0,049	0,000	5,263	0,298	0,033	18,0	1,0	River: Nels
7,92	232	1840	417	7,6	105	64	357	651	148	1,8	0,5	0,0	0,080	0,060	0,282	2,160	0,016	0,108	0,107	0,770	13,150	0,626	0,033		0,5	River: Hoops
8,22	437	3508	920	14,7	104	134	396	1390	458	1,9	0,5	0,0	0,102	0,041	0,847	3,702	0,017	0,303	0,083	0,000	3,346	1,026	0,035	22,7	-0,4	River: Kaisers
7,93	247	1913	505	8,6	64	76	254	716	224	1,3	1,1	0,0	0,082	0,055	0,381	2,215	0,019	0,100	0,022	0,295	6,788	0,682	0,030		1,8	River: Voogds
8,11	344	2158	528	8,8	75	99	260	885	237	0,8	0,6	0,0	0,080	0,007	0,040	2,272	0,002	0,191	0,007	0,334	4,681	0,104	0,003	19,3	-0,2	River: Kogmans.
6,15	21	157	30	4,4	8	5	27	48	14	0,5	0,4	0,0	0,088	0,286	0,014	0,138	0,020	0,437	0,294	0,014	12,304	0,109	0,113	22,2	1,0	TMS
7,32	88	645	108	6,6	57	21	159	175	65	0,6	2,0	0,0	0,082	0,040	0,041	0,467	0,023	1,629	0,184	11,696	8,419	0,587	0,233	18,0	0,1	Malmesbury
7,21	64	473	78	0,8	39	20	123	119	55	0,3	0,8	0,0	0,080	0,022	0,052	0,417	0,020	0,443	0,095	0,000	8,233	0,465	0,180	19,0	0,1	Witteberg
7,59	453	3078	862	16,4	71	114	204	1530	219	1,7	1,8	0,1	0,133	0,065	0,431	4,631	0,019	0,834	0,380	0,648	7,605	0,776	0,102	21,1	-0,2	Bolkeveld
7,42	1258	8798	2421	64,5	208	328	248	4981	482	5,0	0,5	0,4	0,086	0,036	1,068	14,450	0,028	6,321	0,967	1,510	3,395	3,160	0,407	20,3	-3,0	Enon

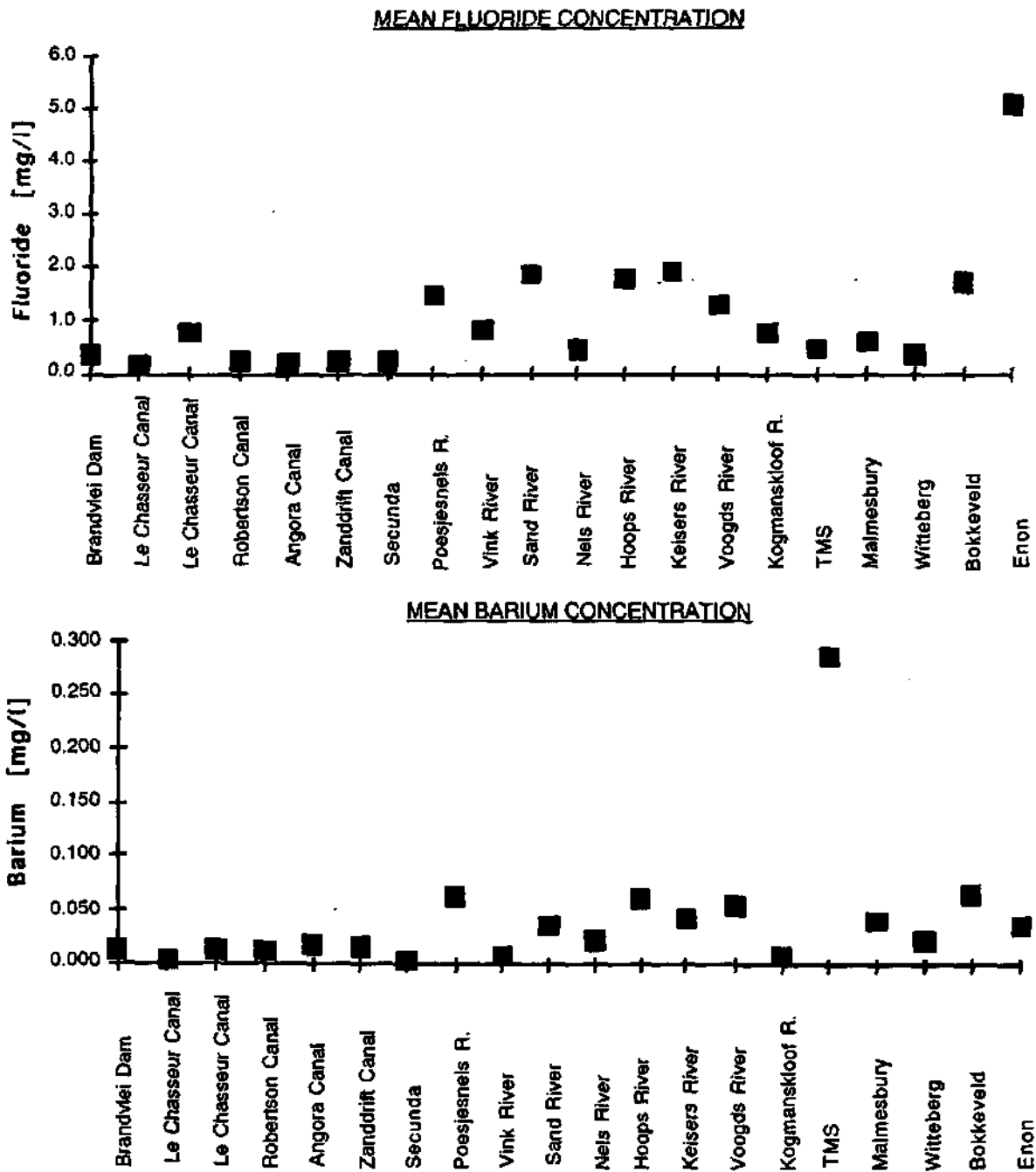

Figure 3.15: Mean fluoride and barium concentrations of the different sources.

Table Mountain Sandstone (see bottom Figure 3.15), where it is at least four times more abundant than in any other source.

SURFACE WATER

The water from the tributaries is the highest salinised surface water and, with the exception of the Nels River, much higher than the water in the main channel and the ground water of the Malmesbury-, Table Mountain- and Witteberg Groups. Iron and zinc concentrations in the tributaries are low, while strontium tends to be high.

Silica is low in analyses from the main channel.

ANALYSIS OF VARIANCE

Variable mean concentrations of individual ions in samples from the various water sources in the study area indicate that significant differences in the chemical composition of most of these populations exist (cf. pages 53 - 55). Similarly, the mean ratios of the ^{18}O and ^2H isotopes suggest different origins of ground-water and surface-water sources (cf. pages 57 - 63).

To test the significance of these observations, the variances between the different sources were determined for all variables analysed.

All ANOVAs were done under the assumption that the individual samples collected were independent from each other. It was also surmised that the chemical concentrations followed a log-normal distribution as many geological variables do¹. The results of the analyses of twelve chemical parameters that produced significant F-test values are shown in Appendix 14² (F-test values which were significant at 95%, i.e., >1.75 , are printed bold).

Out of 22 variables determined, 13 yielded significant F-test results. In the table below, these 13 variables are sorted according to the number of times they were significant. The ions Al, Ba, Cu, Fe, Mn, NO_2 , Si and Zn were never significant. No ANOVA was done for pH.

Alk	37
EC	36
Ca	35
Mg	32
Na	31
Cl	31
SO ₄	28
Sr	20
K	12
B	11
Br	10
F	5
NO ₃	2

The groups that were compared are shown in Table 3.8. This table is subdivided into surface-water sources: (a) upstream of the study area (H1R01Y to H4M017), (b) major tributaries of the Breede River in- and outflow from the study area (H4M018 to H5M004)

¹ Comparison of the normal and log normal distributions of the EC- and Na-samples indicated a log normal distribution of the chemical parameters for which the calculated F-test values were also considerably higher. This was not the case for the environmental isotopes ^{18}O and ^2H .

² Not included are the results for NO_3 , where significant values were only calculated for Vink River versus Bokkeveld (1.90) and versus TMS (1.84).

and (c) ground water from five different geological formations. It displays the number of variables (out of the maximum of 13) for which the F-test between the different sources was significant at the 95% confidence level.

As can be seen from Table 3.8, there is neither a significant difference between the intake sources nor between the three tributaries. Except for Enon¹ and Witteberg for which only a few samples were available, significant differences exist between the remaining ground-water sources.

Also worth mentioning is the observation that (except for Witteberg samples and the Vink River water) only Bokkeveld water is similar to the water in the main tributaries.

Table 3.8: ANOVA results displaying the number of variables out of a maximum of 13 for which the F-tests between the different sources were significant at the 95% confidence level (see the accompanying map for site positions).

	H1R01Y	Dam	H4R04U	H4H017	H4M18	H4H019	H5H004	H3H011	Enon	Witteberg	Bokkeveld	TMS	Malmesbury
	Input			Tributaries and Output					Ground water				
H1R04Y	-												
Dam		-											
H4R04U			-										
H4M017				-									
H4M018	8	9	9	9	-								
H4M019	8	7	8	8		-							
H5M004			3		3	1	-						
H3H011	8	7	8	8				-					
Enon					7	8		6	-				
Witteberg		1	3	1	4			1		-			
Bokkeveld	10	8	9	10		1	3		8	6	-		
TMS					11	12	10	10		4	12	-	
Malmesbury	3	3	4	2	7	2		6	2		8	6	-

Chemically, Bokkeveld-, Malmesbury and, to a lesser extent Witteberg waters differ significantly from the input water. This holds also true for water from the tributaries. The change which the water undergoes between H4M017 and H5M004 is not reflected in ANOVAs, because major changes in the chemistry occur only during a relatively short period of the year.

Water from the cited tributaries is similar in composition, but differs slightly from that at H5M004.

¹ NB: All 21 parameters were only available for samples from one Enon source. This source is not regarded as representative of ground water in the Enon Formation of the area.

TMS- and, to a lesser degree, Malmesbury water is significantly different from water in the tributaries which is rather similar to Bokkeveld.

For seven out of ten possible combinations, the sampled ground-water sources differ significantly from each other.

3.2.5 ISOTOPES

The use of environmental isotopes as natural tracers and indicators for hydrological processes can be very instructive to get insight into the operation of an aquifer system.

Environmental isotopes comprise the naturally occurring isotopic species of a wide range of elements of natural or anthropogenic origin. The isotopic ratios of these elements can be altered by fractionation processes, such as changes of phase, chemical exchange and radioactive decay. In this report, the isotopic characteristics of the water itself will be discussed with the emphasis on the stable isotopes oxygen-18 (^{18}O) and deuterium (^2H or D). The stable isotope content of water resources, being a conservative property of ground water, is considered a reliable tool for determining the origin of ground water and for distinguishing between possible recharge areas and processes.

Vapour rising from oceans and lakes is depleted in the heavy isotopes relative to the water surface by 12 - 15‰ in ^{18}O and 80 - 120‰ in deuterium. Because of continuous fall-out of the heavier isotopes during storm events, while air masses are moving inland, the isotopic composition of rain water becomes increasingly lighter further away from the coast (continent effect). Furthermore, the concentration of the heavy isotopes in rain water decreases during a single rainfall event: the more rain that falls during a particular storm, the lower the average concentration of oxygen-18 and deuterium will be (quantity effect). Finally, because of the temperature at which the condensation occurs, the heavy isotope content of rainfall depends on the rise of moist air mass (altitude effect).

For describing the isotope concentrations, it is customary to work with the isotopic δ -values rather than using absolute concentrations.

Delta notation:

The variations of the isotopic ratios D/H and $^{18}\text{O}/^{16}\text{O}$ in water samples are expressed as per mille differences ($\delta\text{‰}$), regarding the isotopic composition of mean ocean water, which is the reference standard SMOW:

$$\delta\text{‰} = \left(\frac{R_{\text{sample}}}{R_{\text{SMOW}}} - 1 \right) \times 1\,000$$

where R is the isotope ratio D/H or $^{18}\text{O}/^{16}\text{O}$. Thus a sample which has $\delta^{18}\text{O} = -5$ has an ^{18}O content 5 ‰ lower than that of the mean ocean water. The abundance of the three main isotopic species of water in SMOW is H_2^{16}O 99,73 percent, HD^{16}O 0,031 percent and

H_2^{18}O 0,199 percent. The usual accuracy in $\delta\text{‰}$ determination is 1‰ for D/H and 0,1‰ for $^{18}\text{O}/^{16}\text{O}$. Because of the fact that in natural waters the relative variations of the D/H ratios are generally five to eight times higher than those of $^{18}\text{O}/^{16}\text{O}$, the accuracy for both hydrogen and oxygen is in practice comparable.

The isotopic nature of water is controlled by fractionation processes which can be summarised as follows:

- i) Water in the liquid phase is being enriched in heavy isotopes during evaporation, while water vapour is being depleted in heavy isotopes during condensation.
- ii) Fractionation of isotopes with changes of phase increase with decreasing temperature. This phenomenon produces seasonal isotope variations with winter precipitation depleted in heavy isotopes, latitude variations and altitude variations (Friedman *et al.*, 1964 and Moser & Stichler, 1970).

The last effect is important in regional geohydrological studies when differentiation of (ground) water derived from different altitudes may be made. The altitude effect may change regionally, but in general it is about 0,3‰ decrease in ^{18}O content and 2,5‰ decrease in D content for 100 m increase in elevation.

- iii) The ratio of δ_{18} to δ_{D} is affected during the change of phase by thermodynamic processes. Especially, when water evaporates, then the liquid phase will be enriched in oxygen-18 relative to deuterium (the lighter HD^{16}O molecules can leave the liquid surface easier than the heavier H_2^{18}O molecules).

Variations of deuterium and oxygen-18 content in precipitation are linearly correlated (Craig, 1961). The relation

$$\delta\text{D}\text{‰} = 10 + 8 \cdot \delta^{18}\text{O}$$

best fits the points representing the isotopic composition of rainfall samples all over the world, at least for negative values relative to SMOW. Although the intercept may vary in some places, the slope of 8 is generally preserved.

Individual rain events show widely scattered isotopic composition, the average (annual) rainfall tends to be rather constant within 0,5 - 2‰ $\delta^{18}\text{O}$ (Gat & Tzur, 1967).

Evaporation line:

Precipitation which has undergone significant evaporation during its fall does not obey the above relation. Heavy isotopes are enriched in different proportions (Craig, 1961a, Ehhalt *et al.*, 1963 and Woodcock & Friedman, 1963).

In a ($\delta^{18}\text{O}$, δD) diagram, a line of the equation:

$$\delta\text{D}\text{‰} = a \cdot \delta^{18}\text{O}\text{‰} + b$$

with $4 < a < 8$ and $b < 10$, can usually be fitted to the main points which represent the isotopic composition of waters with the same initial isotopic composition, but which have undergone different degrees of free surface evaporation under similar environmental conditions.

The composition of ground water may differ from the mean composition of the rainfall, because not all the precipitation may infiltrate at the same rate: spring and summer precipitation may evaporate in part or total before infiltration occurs.

Within the aquifer, the isotopic composition does not change unless exchange oxygen with the host rock takes place. Except in the case of thermal waters, this exchange is very slow and does not normally occur (Craig, 1963).

Rainfall in South Africa shows a strong dependence on the season and rain water displays a very large scatter in deuterium. A considerable portion of the samples is heavier than ocean water. It is assumed that the high deuterium contents are the result of evaporation of the raindrops during their fall to the ground. The largest enrichment occurs in light showers which fall on hot dry days. Enduring rain with high total precipitation tends to be lighter.

Ground water throughout South Africa contains considerably less deuterium than rain- or river water (in average -3,8%). It can therefore be concluded that ground water is replenished not continuously, but mainly from occasional heavy downpours (Vogel *et al.*, 1963).

DEUTERIUM AND OXYGEN-18

Malmesbury

Rocks of the Malmesbury Group occur only on the eastern side of the valley. Twenty-three sites, identified as "Malmesbury", were sampled during the project. Stable isotopes were determined for 17 of these sites. Three of them lie just downstream of the Worcester Fault that separates the Malmesbury from the Table Mountain Sandstone. Chemically, and in their isotopic composition, there is no difference between these samples from the Malmesbury and the TMS nearby. These holes are therefore not included in Table 3.9.

There is a general trend for conductivities to increase towards the Breede River Valley. Regarding the isotopic composition, the holes between the farms Vink River (VR) and Kruispad (KD) show similar, slightly lower ratios with $\delta^{18}\text{O} < -5$ and $\delta^2\text{H} < -28$. The remaining holes, with the exception of the one sample from DP08, have higher ratios.

Table 3.9: Distribution of $\delta^{18}\text{O}$ and $\delta^2\text{H}$ values and mean electrical conductivities in mS/m for 12 Malmesbury Group sites.

Number	n	^{18}O					^2H					EC
		Min	Max	Mean	Std-d.	Var.	Min	Max	Mean	Std-d.	Var.	Mean
DP04	3	-5.1	-4.7	-4.90	0.16	0.03	-25	-22	-23.3	1.2	1.6	32
DP06	4	-4.8	-4.5	-4.73	0.13	0.02	-26	-21	-23.5	2.1	4.3	72
DP08	1	-5.6	-5.6	-5.60	0.00	0.00	-34	-34	-34.0	0.0	0.0	152
DP09	6	-5.1	-4.5	-4.82	0.20	0.04	-27	-22	-24.7	1.6	2.6	141
KD01	4	-5.1	-5.0	-5.05	0.05	0.00	-32	-27	-28.8	1.9	3.7	127
KD03	4	-5.4	-5.2	-5.33	0.08	0.01	-34	-27	-30.3	2.9	8.2	75
NE01	3	-4.9	-4.8	-4.87	0.05	0.00	-28	-22	-25.0	2.4	6.0	129
NE02	4	-4.9	-4.2	-4.58	0.26	0.07	-28	-17	-24.3	4.3	18.2	52
NE03	4	-5.0	-4.3	-4.70	0.27	0.07	-29	-23	-25.3	2.3	5.2	130
NE08	4	-6.2	-6.0	-6.08	0.08	0.01	-37	-34	-35.5	1.1	1.3	71
RE01	6	-5.5	-3.0	-4.60	0.85	0.72	-28	-13	-21.8	5.1	26.5	105
VR01	4	-7.2	-6.7	-6.98	0.18	0.03	-42	-42	-42.0	0.0	0.0	130
	47	-7.2	-3.0	-5.13	0.78	0.60	-42	-13	-27.6	6.5	42.0	100.7

Table Mountain Group

Water samples from 25 boreholes and fountains sampled were originally classified as belonging to the Table Mountain Group (TMS). Seventeen of these sites were analysed for isotopes. Because of their relatively high isotope ratios, two sites (F1 and RL01) are not included in the statistical analysis in the table below.

Table 3.10: Distribution of $\delta^{18}\text{O}$ and $\delta^2\text{H}$ values and mean electrical conductivities in mS/m for 17 Table Mountain Sandstone sites.

Number	n	^{18}O					^2H					EC
		Min	Max	Mean	Std-d.	Var.	Min	Max	Mean	Std-d.	Var.	Mean
AF	4	-6.2	-6.0	-6.07	0.08	0.01	-38	-30	-33.8	3.0	9.2	15
B7	1	-6.6	-6.6	-6.60	0.00	0.00	-38	-38	-38.0	0.0	0.0	47
DN06	5	-6.9	-6.8	-6.86	0.05	0.00	-44	-30	-37.8	4.5	20.2	17
NG04	3	-7.1	-6.8	-6.97	0.12	0.02	-42	-40	-41.0	0.8	0.7	5
NG05	4	-7.2	-6.1	-6.83	0.43	0.18	-41	-37	-39.8	1.6	2.7	4
NG06	1	-7.0	-7.0	-7.00	0.00	0.00	-42	-42	-42.0	0.0	0.0	4
PR18	4	-6.9	-6.6	-6.73	0.13	0.02	-42	-38	-39.0	1.7	3.0	10
PY01	4	-7.6	-6.5	-6.88	0.43	0.18	-47	-36	-40.5	4.4	19.3	20
RY01	4	-6.3	-6.2	-6.23	0.04	0.00	-38	-34	-35.8	1.5	2.2	32
RY04	3	-6.5	-6.2	-6.33	0.12	0.02	-38	-37	-37.3	0.5	0.2	54
TY01	4	-6.8	-5.6	-6.48	0.51	0.26	-40	-32	-37.3	3.3	10.7	22
TY02	4	-7.0	-6.6	-6.75	0.15	0.02	-40	-39	-39.5	0.5	0.3	32
TY04	4	-6.8	-6.4	-6.60	0.20	0.04	-41	-39	-39.8	0.8	0.7	20
U	4	-6.7	-6.3	-6.55	0.15	0.02	-40	-37	-38.8	1.1	1.2	14
Y	4	-6.4	-6.2	-6.30	0.07	0.01	-38	-34	-35.8	1.5	2.2	40
ZN01	4	-6.2	-6.0	-6.08	0.08	0.01	-36	-32	-33.8	1.5	2.2	20
ZN03	6	-6.4	-6.1	-6.25	0.11	0.01	-35	-27	-33.0	2.8	7.7	13
	63	-7.6	-5.6	-6.53	0.37	0.14	-47	-27	-37.4	3.5	12.5	20.7

The June sample, "RY04", had an unacceptably high $\delta^{18}\text{O}$ value of -2,20 and is also excluded from the table. Included in the table below were, however, "ZN01", identified by Bertram as TMS plus Bokkeveld because of its close agreement with "ZN03" nearby and borehole "AF" along the Konings River which, according to the surface geology, was drilled in Bokkeveld but displays chemically and isotopically a TMS character. Their water is probably derived from TMS that underlies the Bokkeveld.

From the samples listed, "TY01" taken in June 1990, has a high $\delta^{18}\text{O}$ value. Regarding the site "Y", a weak borehole next to a dam, the possibility exists that it is not a pure TMS source. Apart from these exceptions, there is little variation around the mean values, especially the $\delta^{18}\text{O}$ ratios are rather constant. Furthermore, there seems to be a tendency of lower $\delta^{18}\text{O}$ values for sites near the higher mountain ranges. The electrical conductivity of samples taken throughout the year does, in general, show little variation. Conductivities above ≈ 30 mS/m occur in holes near TMS boundaries. The extremely low values of 5 mS/m and less are restricted to sites within the Langeberg Mountains. The latter are also isotopically the lowest due to the altitude effect.

Bokkeveld Group

Rocks of the Bokkeveld Group occur on either side of the Breede River. Sampling sites are, therefore, rather well distributed throughout the area. Eighteen sites, classified as Bokkeveld, were sampled on a regular basis. Two of these have now been grouped under TMS, while one of the original TMS sites (RL01) is now included under Bokkeveld.

Table 3.11: Distribution of $\delta^{18}\text{O}$ and $\delta^2\text{H}$ values and mean electrical conductivities in mS/m for 15 Bokkeveld sites.

Number	n	^{18}O					^2H					EC Mean
		Min	Max	Mean	Std-d.	Var.	Min	Max	Mean	Std-d.	Var.	
AB	4	-6.5	-6.2	-6.27	0.13	0.02	-41	-37	-39.3	1.5	2.2	544
B5	5	-5.8	-5.4	-5.58	0.18	0.03	-39	-31	-33.2	2.9	8.6	250
DN08	3	-3.7	-3.5	-3.63	0.09	0.01	-25	-23	-24.0	0.8	0.7	155
G33570	1	-5.1	-5.1	-5.10	0.00	0.00	-34	-34	-34.0	0.0	0.0	682
GE01	3	-6.0	-5.5	-5.83	0.24	0.06	-33	-32	-32.7	0.5	0.2	32
MD07	5	-4.7	-4.3	-4.52	0.13	0.02	-25	-24	-24.4	0.5	0.2	145
MD08	3	-5.1	-4.7	-4.93	0.17	0.03	-31	-25	-28.3	2.5	6.2	139
PR01	4	-5.0	-4.0	-4.48	0.43	0.19	-31	-24	-26.8	2.7	7.2	76
RL01	4	-6.2	-5.6	-5.93	0.28	0.08	-34	-30	-32.5	1.5	2.3	128
RY08	1	-3.5	-3.5	-3.50	0.00	0.00	-25	-25	-25.0	0.0	0.0	237
RY10	2	-5.9	-5.7	-5.80	0.10	0.01	-34	-33	-33.5	0.5	0.3	85
VD02	4	-5.6	-3.8	-4.65	0.77	0.59	-30	-22	-26.5	3.2	10.3	87
VD03	4	-5.9	-5.1	-5.63	0.31	0.10	-30	-27	-29.3	1.3	1.7	57
VD04	4	-3.5	-2.5	-3.18	0.40	0.16	-20	-14	-17.8	2.3	5.2	260
ZN02	4	-5.9	-3.3	-4.78	1.01	1.03	-34	-23	-28.0	4.3	18.5	318
	56	-6.5	-2.5	-5.10	1.03	1.05	-41	-14	-29.6	6.1	37.1	191.8

If the summarised information in Table 3.10 is compared with Table 3.11, it is obvious that the variation of the isotope ratios in between the samples and within the group is considerably higher amongst the Bokkeveld. Yet there is little overlap between the two groups. The isotope ratio range and distribution of the Bokkeveld are, however, similar to that of the Malmesbury, but the latter contains considerably fewer salts as shown by the conductivity values.

There may be some reason to include site "GE01" in the TMS group: the isotopic ratios and the conductivities are similar, the hole is strong and may be connected with the fountain on the northern slope of Skurwekop, approximately 1,5 km south.

Anomalies evident in Table 3.11 are the high standard deviation for "ZN02" and "VD02" caused by comparatively high isotope ratios in September 1990.

Witteberg Group

In the Robertson area, rocks of the Witteberg Group occur in the surroundings of the main road bridge over the Vink River. They are exposed in a three kilometre wide belt with a north-easterly trend which ends at the Worcester fault. A well and a fountain along the Noree road were sampled regularly. Two other sites, "JF01" and "JF02", situated along the Worcester-Villiersdorp road, were visited at the beginning of the project, only to broaden the Witteberg data base.

Samples from the two areas compare well, although there is a tendency of slightly lesser isotope ratios and conductivities in the "JF" samples. Mean values for the Vink River area are -4,56 and -24,6 for the isotope ratios respectively and 69,4 for the conductivity. The samples showed only small variations throughout the year.

Table 3.12: Distribution of $\delta^{18}\text{O}$ and $\delta^2\text{H}$ values and mean electrical conductivities in mS/m for four Witteberg sites.

Number	n	^{18}O					^2H					EC Mean
		Min	Max	Mean	Std-d.	Var.	Min	Max	Mean	Std-d.	Var.	
AA	3	-4.9	-4.4	-4.67	0.21	0.04	-27	-23	-25.3	1.7	2.9	62
JF01	1	-4.4	-4.4	-4.40	0.00	0.00	-30	-30	-30.0	0.0	0.0	55
JF02	1	-5.5	-5.5	-5.50	0.00	0.00	-30	-30	-30.0	0.0	0.0	34
Z	4	-4.8	-4.3	-4.48	0.20	0.04	-26	-23	-24.0	1.2	1.5	75
	9	-5.5	-4.3	-4.64	0.37	0.13	-30	-23	-25.8	2.7	7.1	63.9

Isotope ratios of samples from the Witteberg Group are, in general, noticeably higher than those of the other groups discussed so far.

Surface water

Figure 3.16 shows the variations of $\delta^{18}\text{O}$ and $\delta^2\text{H}$ between October 1988 and March 1991 for the two weirs in the Brede River at the upper and lower end of the area of investigation

and for the two major tributaries, the Vink- and Kogmanskloof Rivers. The following deductions can be made from this graph:

- The density of measurements is not sufficient, as shown by the drastic changes in September 1990, when two samples each were analysed for the Vink- and Kogmanskloof Rivers.
- There is an indication of low isotopic ratios during the winter months, i.e., between approximately April and August and high ratios during the summer.

While there is a 99,5% correlation between the mean ratios (cf. Figure 3.17) there is also a high correlation between these isotope ratios and the mean conductivity of 91% and 94% respectively.

It is remarkable that the June- and September isotope ratios are lower at H5M004 than at H4M017 or that of the water released into the Le Chasseur canal (H1R01Y).

While the low values measured at H5M004 in June can be attributed to a major rainfall event which occurred before the measurements at this weir but after sampling of the other measuring points higher up, no such explanation can be given for the September measurements when all tributaries showed higher $\delta^{18}\text{O}$ ratios.

The rise of the $\delta^2\text{H}$ ratio in December 1990 from -13 at H4M017 to -10 at H5M004, in spite of smaller ratios in all but one of the tributaries, indicates predominant evaporation and/or irrigation return flow. The $\delta^{18}\text{O}$ ratios follow the same trend.

Table 3.13: $\delta^{18}\text{O}$ ratios at different sites along the Breede River and its tributaries (lowest values for the respective sampling periods are printed in italics).

	Oct 1988	Apr 1989	Jun 1990	Sep 1990	Dec 1990	Mar 1991
H1R01Y			-4,5	-4,2		+1,7
Breede R1	-3,6	-5,9				
H4R04U	-0,2	+1,5	-0,4	-1,6	-1,9	-0,6
Canal C2		-5,8				
H4M17	-3,4	-5,9	-4,4	-4,1	-2,0	-0,5
H4M18	-2,3	-4,1	-2,5	-3,6	-2,6	-2,1
H4M19	-2,7	-5,5	-3,4	-3,8	-3,2	-2,2
Nels River			-4,4	-4,0	-2,8	-2,5
Hoops River			-3,8	-3,9	-2,6	-2,4
H4H16	-3,3	-5,5				
H4H11			-3,3		-1,0	-1,8
H3M11	-2,6	-4,5	-4,3	-3,4	-1,9	-1,0
H5M04	-3,2	-5,6	-6,1	-4,8	-1,6	-0,6

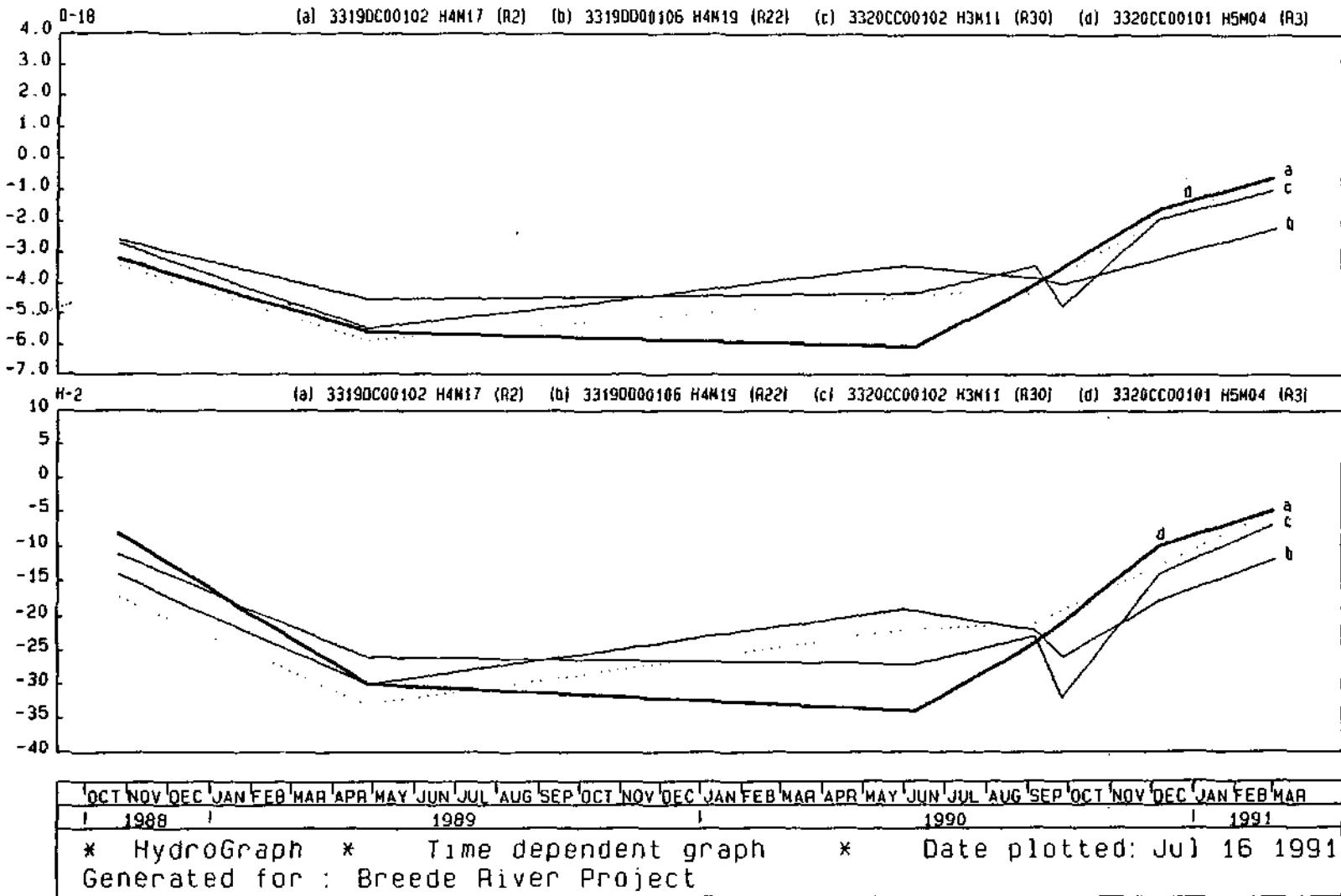
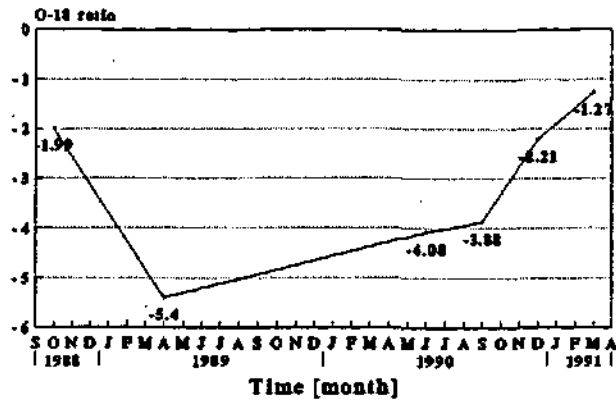
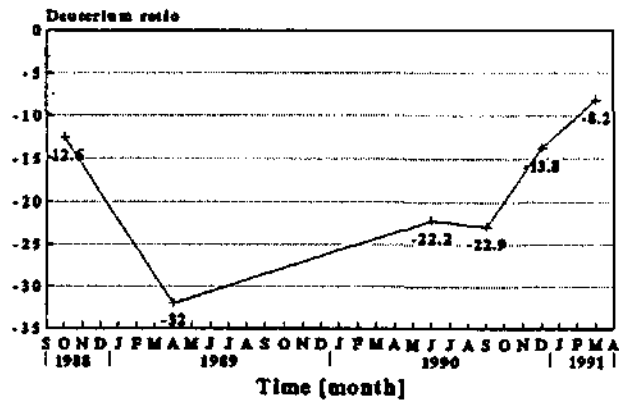

Figure 3.16: Variations of $\delta^{18}O$ and δ^2H between October 1988 and March 1991 for the two weirs in the Breede River at the upper and lower end of the area of investigation and for the two major tributaries, the Vink- and Kogmanskloof Rivers.

BREDE RIVER and TRIBUTARIES
Mean O-18 ratio



BREDE RIVER and TRIBUTARIES
Mean Deuterium ratio



BREDE RIVER and TRIBUTARIES
Mean conductivities

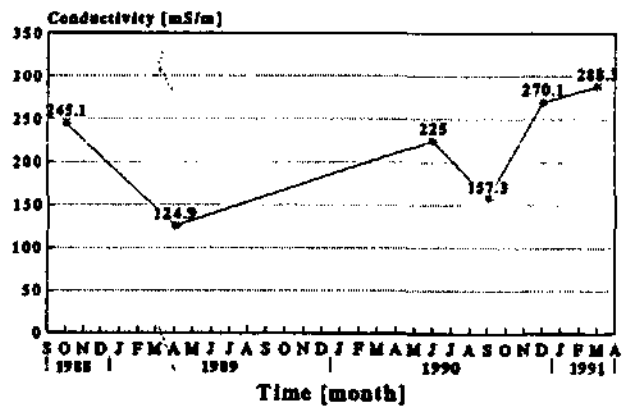

Figure 3.17: Correlation between mean isotope ratios and the mean conductivity of the Brede River and its tributaries.

Table 3.14: $\delta^2\text{H}$ ratios at different sites along the Breede River and its tributaries (lowest values for the respective sampling periods within the project area are printed in italics).

	Oct 1988	Apr 1989	Jun 1990	Sep 1990	Dec 1990	Mar 1991
H1R01Y			-24	-25		+6
Breede R1	-16	-33				
H4R04U	-2	+7	-4	-10	-12	-5
Canal C2		-34				
H4M17	-17	-33	-22	-21	-13	-5
H4M18	-12	-35	-17	-25	-14	-15
H4M19	-14	-30	-19	-22	-18	-12
Nels River			-22	-21	-14	-11
Hoops River			-21	-22	-16	-13
H4H16	-10	-30				
H4H11			-14		-11	-12
H3M11	-11	-26	-27	-23	-14	-7
H5M04	-8	-30	-34	-24	-10	-5

Analyses of variance for oxygen-18 and deuterium (see Appendix 15) show significant differences between dam water as well as TMS and practically all other components. Unexpected and difficult to explain is the observation that ^{18}O of Bokkeveld and Malmesbury differ significantly from run-off in the Poesjesnels River, but that no further significant differences occur. It may be due to the slightly higher mean concentrations of these groups relative to the TMS for which there are also 25% more samples.

STRONTIUM ISOTOPE RATIOS

Traditionally, the application of isotopes to studies of the environment has been restricted to the light elements, e.g., hydrogen/deuterium, carbon, oxygen, nitrogen and sulphur. These are some of the so-called "stable isotopes" of which the isotopic composition is not affected by radioactive decay, be it of the element itself or of a parent nucleus. However, the isotopic composition of such elements is affected by fractionation due to various processes. These may be atmospheric (evaporation, precipitation) or biogenic (take-up in organisms and plants) in nature. Thus the study of changes in the isotopic compositions of the lighter "stable" isotopes has proved to be extremely useful in studies of systems involving the environment, plants, organisms, etc.

Another group of isotopes consists of the "radiogenic" elements which are characterised by having one or more isotopes that, through time, receive contributions from the decay of radioactive parent isotopes. Quite a large number of elements falls in this category, but not all are routinely studied. Examples of radiogenic isotopes that are commonly studied in geological applications (for age determination and isotope geochemical investigations) are strontium, lead and neodymium. In general, such elements are heavier than the stable

isotopes and, as a result, are significantly less affected by fractionation due to biogenic or atmospheric processes - or even geological processes for that matter. A second point of significance is that, although the isotopic composition of such elements changes with geological time, the rates of change are so slow that in studies of modern environments, the changes are too small to be detected and such elements can, for practical purposes, be regarded as "stable" elements.

As a result of these attributes, the isotopic compositions of elements such as strontium can "look through" certain modern processes and can be used to "fingerprint" the original source of the materials being studied. The isotopic compositions found in any particular material will reflect the original source of the element plus any components that may or may not have been added from other sources. Processes such as evaporation, biogenic uptake, etc., will not affect the isotopic compositions to any discernible degree.

An example of the application of "radiogenic" isotopic compositions is to trace the sources of ivory and rhinoceros horn. The isotopic compositions found in these materials accurately reflect the geological nature of the region from where the animals originated.

It is clear from the foregoing that the study of the "radiogenic" isotopes can provide very useful information which can be complementary to the information obtained from the lighter "stable" isotopes.

Following a recommendation of the Steering Committee, samples for determination of strontium isotopes were collected in December 1990 from the Breede River and its major tributaries and from a few boreholes in various parts of the area which tap different aquifers. F. Walraven from the Geological Survey has analysed the samples and first reported on the results in April 1991.

Except for river water, the only other important source contributing to the run-off in the Breede River is irrigation return flow. On 25 June 1991, Mr. M. Acker from the Worcester Office of the Department of Water Affairs and Forestry kindly collected two irrigation return flow samples (St 65 and St 66) from drains on the farm Zandvliet CRO117. These drains had previously been monitored by the Department. The $^{87}\text{Sr}/^{86}\text{Sr}$ -ratios of these samples were analysed in December and showed ratios comparable to the river water. Samples 1 to 6 were collected on the farm Goedemoed CRO 128 by Prof. J. H. Moolman from the University of Stellenbosch in May 1992 and originate from a research area which lies between the Klaas Voogds Rivers, the Robertson-Bonnievale Road in the south and the railway line in the north. The last-mentioned samples were analysed in August 1992 and also gave ratios similar to river samples.

Table 3.15: Strontium concentration and ratios in surface-, irrigation-, return flow- and ground water¹.

	Sr [mg/l]	⁸⁷ Sr/ ⁸⁶ Sr	Std. Error	⁸⁶ Sr [µg/l]	Flow [m ³ /d]	⁸⁶ Sr [kg/d]	Source
H4H017	0,083	0,716595	0,000016	34,648	593 053	20,548	Brede
H4H018	1,724				97		Poesjesneis
H4H019	1,428	0,717803	0,000016	596,706	7 776	4,640	Vink
H4H011	1,333	0,716881	0,000023	556,592	?		Keisers
H3H011	0,880				147		Kogmanskl.
H5H004	0,394	0,717141	0,000014	164,549	69 842	11,49	Brede
St. 65		0,715248	0,000008				Return flow
St. 66		0,718114	0,000014				Return flow
1		0,716505	0,000058				Canal water
2		0,716189	0,000013				Dam water
3		0,716704	0,000037				Drain water
4		0,716972	0,000049				Klaasvoogds
5		0,716134	0,000040				drip vinyard
6		0,716154	0,000056				drip adjacent
ZN03	0,050	0,724769	0,000020	21,011			TMS
DN06	0,033	0,729259	0,000014	13,917			TMS
PY01	0,041	0,724181	0,000019	17,221			TMS
TY02	0,035	0,725654	0,000019	14,718			TMS
VR01	1,320	0,726278	0,000013	555,349			Malmesbury
NE01	1,366	0,722871	0,000014	573,137			Malmesbury
N	0,694	0,724166	0,000035	291,487			

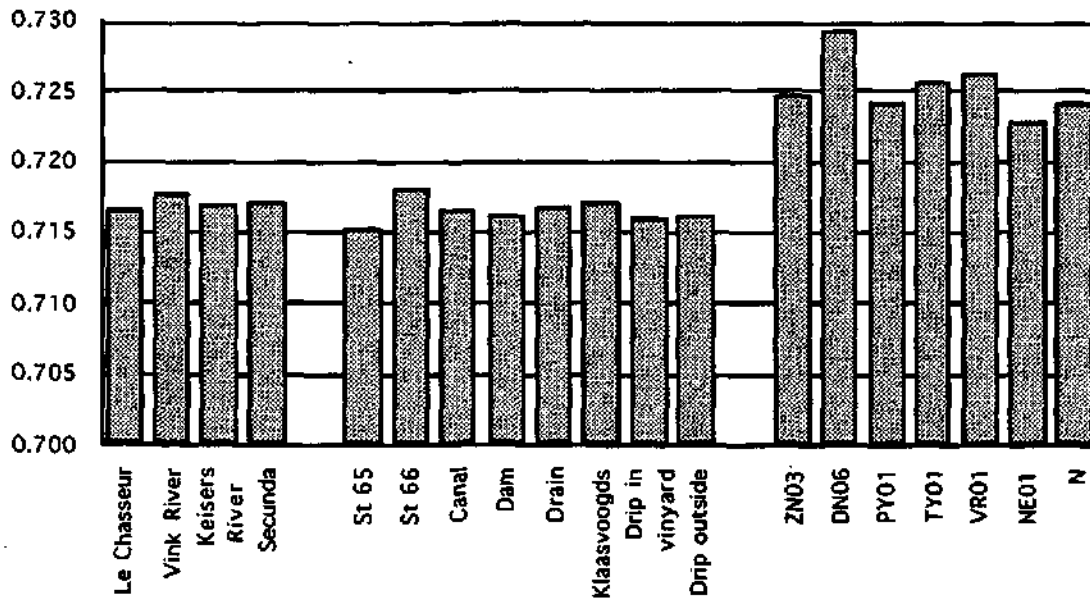

Figure 3.18: Strontium isotope ratios for four river samples, eight irrigation-related samples and seven ground-water samples.

¹ The return flow samples ST 65 and ST66 were taken after the irrigation season 1990/91, samples 1 to 6 after the irrigation season 1991/92 and the others in December 1990.

	River water	Irrigation	Ground water
Mean Sr-ratio	0,71710	0,71645	0,72533
Standard deviation	0,00051	0,00035	0,00203

As can be seen from Figure 3.18, there is a remarkable difference in the isotope ratios of the river- and the ground-water samples. The values for mean ratios and the standard deviations for the three groups quantify the observed differences. The strontium ratio of the irrigation water seems to undergo no important change, e.g., through dissolution of fertiliser, gypsum or salts in the soil. This observation indicates that the river water at H5M004 may contain unspecified quantities of irrigation return flow, but only small amounts of ground water.

There may be a small increase in the strontium ratio of the river water between H4M017 and H5M004. The slightly higher strontium ratios of the tributaries (see Table 3.14) can hardly be responsible for this increase in the Sr-ratio of the Breede River, if one considers the volumes of the tributaries involved. To raise the strontium ratio at H5M004 from an input level at H4M017 (if no input strontium is lost) by adding ground water to the level observed at H5M004, the following relation applies:

$$(1 \cdot 0,716595) + (x \cdot 0,72533) = (1 + x) \cdot 0,717141$$

This would indicate that approximately 6,7% of the strontium that passed H5M004, at the sampling time may have been derived from ground water.

The following mean Sr-concentrations were observed in the samples taken in December 1990:

Witteberg	0,347 mg/l
Bokkeveld	0,963 mg/l
TMS	0,080 mg/l
Malmesbury	0,623 mg/l
Le Chasseur	0,078 mg/l
Secunda	0,406 mg/l

As can be expected, the TMS water had very low Sr-concentrations (see Table 3.15). The concentration in the Breede River at Le Chasseur was the second lowest. It increased more than five-fold between Le Chasseur and Secunda. Water samples from the remaining formations have the next highest concentrations, while the tributaries (except Kogmanskloof) exhibit the highest values. Their concentrations are between ≈ 2 and 4,4 times higher than that of the Breede River at Secunda.

If one uses the above calculated relation of 6,7%, then the volume(s) of ground water necessary to raise the strontium ratio to the levels observed, depend on the strontium concentration(s) chosen: for TMS it would be $0,067 \cdot \frac{0,406}{0,080}$ or $\pm 34\%$ of the run-off (at

H5M004 plus the exports of the Angora and Zanddrift Canals); the corresponding value for Bokkeveld would be less than 3%.

This observation leaves us with two scenarios:

- i) a significant proportion of the water in the Breede River at Secunda is of TMS origin which has a freshening effect on the water in the Breede River or
- ii) a very small percentage of the flow in the Breede River at Secunda is derived from mainly Bokkeveld water; the quantity of salt originating from in-flowing ground water is of minor importance.

In both cases, ground water cannot be a significant source for the salt load of the Breede River.

4. PUMPING TESTS

Greeff (1990) and Jolly (1990) have conducted and evaluated pumping tests in an attempt to establish ground-water flow rates. To obtain a regional estimate for transmissivities, these pumping tests were re-evaluated. Dry and weak boreholes were also considered for a representative regional transmissivity estimate.

POESJESNELS RIVER

Test- and observation holes had been drilled along six sections in the Poesjesnels River area for investigations carried out by Greeff (1990). These test holes were drilled to depths of up to 100 m, while the observation holes varied in depth between ± 15 and 35 m. The reported

Table 4.1: Poesjesnels River Valley: Pumping test results (the first values given for the transmissivity [m^2/d] of this report refer to the pumping test and the second to the recovery test; mean storativities do not include the value for the pumped hole).

Test hole	Observation hole	Results			
		Greeff 1990		This report	
		Transmissivity	Storativity	Transmissivity	Storativity
A1	A1	15,5		8,8 - 14	0,02
	A1a			13 - 15	0,0015
	A1d	15,8	0,0013	8 - 17	0,00005
	A1e			8,8 - 20	0,00037
	A1f			8,1 - 16	0,00069
	MEAN		15,65	0,0013	9,34 - 16,4
B2	B2			34 - 64	0,013
	B2c			37 - 71	0,0059
	B2e			32 - 60	0,012
MEAN				34,33 - 65,0	0,0090
C2b	C2b	8,0			
	MEAN	8,0			
D1a	D1a			13	0,028
	D1			16 - 13	0,000028
	D1e	15,0		15 - 14	0,000075
	D1f			15 - 13	0,000057
	MEAN	15,0		15,33 - 13,3	0,000053
D1d	D1d	27,0		25 - 13	0,0097
	D1b			17 - 13	0,000083
	D1			15 - 13	0,000014
	MEAN	27,0		19,00 - 13,0	0,000032
Ele		145 (T_s)		(- 80 - 100)	
Overall MEAN		42,13 m^2/d	0,0013	19,5 - 26,9	0,003267

yields of the holes varied between $>0,01$ and 23,5 l/s (with a mean of 10,14 and a standard deviation of 7 l/s). Most of the observation holes were drilled very near to the test holes.

This fact and the different water-level response to pumping at the various test sites made the evaluation of some of the tests difficult and/or unreliable. Table 4.1 summarises and compares the results reported by Greeff, as well as the evaluation of this report. The agreement between the values is good.

Borehole E1 could not be properly evaluated. The transmissivity at this site is definitely higher than at the other sites. However, the representative transmissivity for the aquifer, i.e., the mean transmissivity in the cone of depression around all holes of the group seems to be between 80 and 100 m²/d and is slightly lower than the 145 m²/d reported by Greeff. The mean transmissivity at the four sites analysed in this report is ~23 m²/d. Including a value of 8 m²/d for site C2b and 90 m²/d for E1, an overall mean of ~32 m²/d is obtained¹.

BREDE AND VINK RIVER AREAS

Twenty-six deep holes varying between 71 and 100 m in depth and 23 shallower holes with depths between 9 and 44 m were drilled in the Robertson area. Along the Vink River, there are 12 holes, 50 to 80 m deep, and 11 holes between 10 and 18 m deep. Water struck in these holes varied between 0 and 30 l/s. Most of the holes in the Robertson area had low yields as can be deduced from the table below which shows the mean yields:

Area	Deep holes	Observation holes
Robertson	0,3 l/s	0,9 l/s
Vink River	8,7 l/s	8,7 l/s

Three pumping tests were carried out on G-numbered holes that struck water in the deeper lying aquifers, i.e., in Bokkeveld formation (Jolly, 1990). One hole (G 33591) is situated on the left bank of the Breede River below Robertson and the other two along the lower Vink River. Only summarised aquifer test data were given in the report. The reported transmissivities vary between 2,9 - 59 m²/d (alluvium) and 4,1 - 417 m²/d (bedrock) with storativities given as 0,00016 - 0,03333 and 0,00051 - 0,00023 respectively.

The pumping tests of the deep holes in the Breede and Vink River areas were also re-evaluated. The graphs appear in Appendix 3. The calculated yields of the tested holes and the approximate mean transmissivities of the test- and observation holes are as follows:

Borehole No.	Yield	Transmissivity
G 33591	5,5 l/s	~7,5 m ² /d
G 33602	30 l/s	~110 m ² /d

¹ The mean value of 62 m²/d given by Greeff was not determined correctly.

G33603	15 l/s	~115 m ² /d
--------	--------	------------------------

There must be some relationship between the maximum yield of a borehole and the transmissivity. As the maximum yield of a hole approaches zero, the transmissivity will also approach zero. Assuming for the moment that there is a linear relationship between the reported yields and the transmissivities, one finds that the mean transmissivity is ~ 6 times the mean reported maximum yield. One arrives at values shown in the table below if a factor of six is used to estimate the mean transmissivity of all exploration boreholes for the Robertson and the Vink River area.

Area	Deep holes	Observation holes
Robertson	1,8 m ² /d	5,4 m ² /d
Vink River	52,2 m ² /d	52,2 m ² /d

DISCUSSION

The transmissivities in the Vink River area are approximately an order greater than those in the Robertson area. This is probably due to local differences in fracture density and/or fracture permeability. The differences in the mean yield of shallow and deep holes in the Robertson area must be regarded as accidental, although the possibility exists that (some of) the shallow water struck in the deep holes was cut off by the casing. Transmissivity values of the test holes in the Poesjesnels River Valley are slightly lower than those along the Vink River.

The assumption of a linear relation between maximum yield and transmissivity is a simplification that does not account for the effects of aquifer- and well loss. For excessive drawdowns, well losses will lower the yield of a hole, i.e., the yield will increase at a slower rate than the transmissivity. However, the effect this will have on *low*-yielding holes is regarded as *comparatively small*.

Logan (1964) using Thiem's method arrived at an approximation for the transmissivity of

$$T = \frac{1.22 Q}{s_{\max}}$$

assuming that the log ratio of the radius of the depression cone vs. the radius of the pumped borehole equals a constant 3,33. Transmissivities of between 0,5 m²/d to 4,8 m²/d for the Robertson area and 15 m²/d to 45 m²/d for the Vink River area are obtained for the deep and observation holes respectively, if mean yields of 0,3 and 0,9 for the Robertson- and 8,7 l/s for the Vink River area are assumed to be representative and drawdowns of $s_{\max} = 60$ m for deep holes and $s_{\max} = 20$ m for observation holes are used.

Based on the re-evaluation of pumping test data of the exploration holes drilled downstream of Robertson and in the Poesjesnels- and Vink River Valleys, representative transmissivities for the three areas are approximately as follows:

Robertson	Poesjesnels	Vink River
~ 3,5 m ² /d	~ 30 m ² /d	~ 50 m ² /d

5. SYNTHESIS

It seems appropriate to recapitulate the aims of studies carried out in the Breede River area and to review some previous research findings before further evaluations and deductions are made.

At present, the Breede River fulfils a double function as supplier of irrigation water and as drainage system for (irrigation) return flow. The Greater Brandvlei Dam is operated to serve three major purposes:

- (i) Storing of water pumped from the Breede River during the winter season.
- (ii) Release of water for irrigation supply during the summer irrigation season between October and April.
- (iii) Release of water for dilution of river water to balance the salinity level during the irrigation season.

As irrigation extends, the amounts of water required to keep the quality in the Breede River at acceptable levels will rise. At some time in the future, it will become uneconomical to use the dam water for this purpose.

The ultimate aim of all long-term options for the middle Breede River is the abolition of the main river channel as conveyor of water and the replacement of the existing canal system because of its condition and capacity. There are the following alternatives:

- (i) a high-level canal;
- (ii) low-level canal with pump schemes and
- (iii) phased canal and pump schemes.

The hydrological system of that part of the drainage area which was the target area of most studies is highly complex. Gains of the system consist of:

- Ia) run-off in the Breede River above Le Chasseur which is made up by run-off strictly speaking, release from the Greater Brandvlei Dam, irrigation return flow, rainfall and a ground-water component;
- Ib) subsurface inflow of ground water;
- Ic) run-off of the tributaries between Le Chasseur and Secunda;
- Id) Le Chasseur- and Goree Canal imports used for irrigation, including canal seepage and rejects;
- Ie) ground-water recharge and
- If) precipitation onto the Breede River itself, including overland flow.

The losses comprise:

- IIa) run-off at Secunda;

- I**b**) subsurface outflow of ground water;
- I**c**) Zanddrift- and Angora Canal exports and
- I**d**) evapotranspiration.

Because the system does not react instantaneously

- III) changes in the (surface- and subsurface-) storage must also be accounted for.

Within the area, recirculation occurs because of:

- IVa) diversion of river water into canals and direct pumping from the river for irrigation. This leads to canal rejects, canal- and dam seepage, (additional) evapotranspiration and irrigation return flow and, to a much lesser extent, because of
- IVb) ground-water abstraction causing reduced subsurface outflow and/or recharge of the Breede River. Ground-water abstraction also leads to increased evapotranspiration and irrigation return flow.

The above listing comprises all components that must be reasonably well-known when a water balance or a salt balance (which requires additional parameters) is drawn up and also when a management model is developed. All previous studies have dealt with one or the other of these aspects.

Processes that influence the balance can be divided into those that take place in the air, at the surface and underground. As a rule, the processes at the surface are best to be determined, while the other two do not lend themselves to easy and representative measurements and generalisations have often to be made: rainfall and evapotranspiration for an area are deduced from time series measured at a few points. Similarly, processes that take place in the soil or in the saturated zone are construed from a number of point measurements.

Fortunately, it seems, the quantitatively most important processes take place at the surface.

Previous projects carried out in the study area and resulted in the following findings which have an influence on the ground-water component that may contribute to salinisation of the Breede River:

AQUIFER PARAMETERS: Greeff (1990) reported a representative transmissivity value of $62 \text{ m}^2/\text{d}$ and a storativity of $1,3 \cdot 10^{-3}$. Evaluation of the data collected by him in this report produced a somewhat lower transmissivity of $23 \text{ m}^2/\text{d}$ and a storativity of $3,3 \cdot 10^{-3}$.

Re-evaluation of Jolly's pumping tests of bedrock aquifers during the present study yielded transmissivities of $\approx 7,5 \text{ m}^2/\text{d}$ for the Robertson and $110 - 115 \text{ m}^2/\text{d}$ for the Vink River area (cf. p. 28). If, however, the majority of the holes (with yields too small for conducting pumping tests) are also considered when assessing representative transmissivities for these two areas, values of $3,5$ and $50 \text{ m}^2/\text{d}$ respectively are obtained. Jolly (1990) used a transmissivity of $62,2 \text{ m}^2/\text{d}$ in his calculation of the ground-water contribution. A reduction

of this value to 3,5 m²/d for the major part of the stretch between Le Chasseur and Secunda will not only reduce the total inflow, but also the relation between the contribution of the alluvial aquifer and the bedrock aquifers. Jolly (1990, p. 22) calculated the total contribution of ground water to the Breede River as 3500 + 47000 = 50500 m³/d with a minimum salt load of 14 647 t/a¹.

SALINITY: Greeff (1990) gave the average salinity of irrigation water as 312,2 mg/l and that of seepage return flow as 2965,6 mg/l.

Flügel (1989b) reasoned that irrigation was applied by farmers at an efficiency rate of between 80 and 90 percent and the salt contribution of the soil or from gypsum and fertilisers, etc., was not important (cf. p. 26). Under these premises, the resulting salinities in the tributaries should have been lower. He ascribes the difference to the ground-water contribution.

As the work by Greeff has shown that substantial quantities of salt occur in the weathered zone above Bokkeveld sediments, Flügel's disregard of the non-ground-water sources seems not realistic.

In the 4th BRSRP report (Flügel, 1990), water- and salt-balances were calculated for the Breede River between H4M017 and H5M004 to estimate the saline ground-water seepage. Flügel comes to the conclusion that the positive water balance between December 87 and February 88 indicates little ground-water contributions. He states that the salt balance reveals additional highly saline input. Unfortunately, many of the data referred to, e.g., pumping figures, canal flow or evaporation, have not been reported and can, therefore, not be verified or re-evaluated.

In March 1986 Howard (1986), also from the HRI, carried out continuous conductivity measurements in the Breede River between weirs H4M017 and H5M004. He showed that increasing salinity in the Breede River is associated with the entry of tributaries into the Breede River. The EC measurements also revealed evidence of significant diffuse seepage inflow in the lower regions of this part of the river. The EC rise can possibly be related to the increasing area under irrigation bordering the Breede River. The depicted 2-3 mS/m increase in salinity along a ± 5 km stretch of the Breede River between the Goree pumping station and the McGregor Road bridge (Howard, Figure 3) does not indicate saline ground-water inflow².

¹ See discussion on p. 80.

² The author measured at no-flow conditions in March 1990 an increase of 1 mS/m between a weir upstream of Silverstroom and the McGregor bridge. This distance is about 2,5 km.

If we return to the list of in- and output of the water balance on pages 63 and 64, we find that the different items have been determined *sufficiently accurate, with shortcomings or not sufficient* (see Table 5.1).

Table 5.1: Estimated certainty of values for various water-balance factors.

	Sufficiently	Shortcomings	Insufficiently
Inputs	H4M017	Run-off in Tributaries	G-W inflow
		G-W recharge	Rainfall & sheet flow
		Canal imports	
Outputs	H5M004	Canal exports	G-W outflow
		Evapotranspiration	
Storage	River and dam?		
Recirculation		Abstractions	Canal & dam seepage
			Irrigation return flow

Not included in this table are the salt concentrations of the various components. The surface-water salinity is in general sufficiently well-known. However, a representative salinity value for the various ground-water components has only partly been established.

In an attempt to explain the observed differences in the salt in- and output, Flügel and Jolly have drawn up water balances. Flügel has based his approach (1989b) on supposed irrigation efficiencies in the Vink River catchment (and elsewhere in the study area), assuming that salt dissolution and soil weathering were negligible and all salt passing H4M018 was derived from irrigation water or saline ground water. This is in contradiction with Greeff's findings. In his 1989c paper, Flügel used results from permeability tests in the alluvial aquifers near Robertson to calculate a ground-water flow rate for a shallow aquifer. The relatively small salt input from this aquifer cannot explain the salt deficit in the salt balance for the study area. This deficit is allocated to the deep ground water. In his final report (Flügel, 1990), the ground-water contribution is deduced from a positive water balance (in essence) during the irrigation season. The difference is attributed to the not gauged tributaries and to ground water. The salt balance was positive for all months of the year. After subtraction of the calculated contributions of the *alluvial-* and the *gravel aquifers*, the excess salt is again allocated to the *deep ground water*.

Jolly (1990) bases his ground-water contribution on an average transmissivity determined in those holes of the shallow and deep aquifers that were tested. According to Flügel's findings, it seems that the contributions of the shallow aquifers can be separately assessed.

Therefore, a representative transmissivity value for the deeper aquifer is required. A transmissivity range for this deeper aquifer is determined in Chapter 4, Pumping tests, which takes all exploration holes in the Robertson-, Vink- and Poesjesnels area into account. If a ground-water contribution of the deeper aquifer, i.e., up to 100 m, is calculated using a value of $T = 5 \text{ m}^2/\text{d}^1$, approximately $4\,000 \text{ m}^3/\text{d}$ enter the Breede River. Slightly higher flow rates are possible but it is doubtful whether this inflow can be ten times higher. Not included is ground water from deep-lying aquifers, i.e., TMS, which may drain along faults and major fractures into the river-bed.

Representative values for the salinity of the deeper aquifer are difficult to assess. The EC measurements of the G-numbered holes appear unreliable. In addition, there is a stratification in most of the holes evidenced by the borehole logs. As the different layers may have, and probably will have, different permeabilities, representative salinity values can only be determined by abstracting, say twice the volume of the hole, from the individual holes before the electrical conductivity is measured.

The problems mentioned, refer to the representative salinity of any individual borehole. Jolly has discussed ground-water quality and pointed out that mean EC values of the hydrocensus (Bertram, 1989) are lower than the mean value for all boreholes, because only holes suitable for irrigation were included in the survey. While this is certainly so, the different transmissivities must also be considered: all the suitable holes have obviously high transmissivities and most of the unsuitable holes have low ones. This observation can be ascribed to natural flushing of the salts. Greeff (1990) describes improving qualities of high yielding new exploration holes during pumping.

The best way of determining the representative salinity EC_{mean} of the ground water seems to weigh the salinities EC_i measured in the individual boreholes according to their transmissivity or, alternatively, their maximum pumping yield Q_i :

$$EC_{mean} = \sum (Q_i \cdot EC_i) / \sum Q_i.$$

In my opinion, the two *shallow* aquifers and the *deep* aquifer are not the only aquifers discharging into the Breede River. If one looks at highly permeable zones, e.g., between the farms Laughing Waters at the southern end of the Sandberg and La Colline (east of the junction of the Goree- and the main road), good quality (TMS) water in large quantities occurs under considerable pressure. If, as it seems, the water of the fountain at La Colline has its origin in the South, its water must have passed beneath the Breede River. Even if its water is not derived from the southern side of the valley, the fact remains that there are

¹ The value of $3,5 \text{ m}^2/\text{d}$ is not regarded as representative for the whole length of the Breede River Valley. However, the ten times higher values for the Vink- and Poesjesnels Rivers are probably caused by increased local fracturing. The length of the section between H4M017 and H5M004 was taken as 40 km and the ground-water gradient as 1 : 100.

highly permeable aquifers under artesian pressure near the river. It appears unthinkable that (some) water from this (and other) aquifer(s) which carries water of good quality, should not seep into the river.

There are a number of indications that ground water is contributing towards the flow in the river. The strontium isotope ratios show it¹, the oxygen-18 and deuterium suggest it and (unexplained) gains in the river flow noticed (Bruwer, personal communication) and found by Flügel in his balance calculations, also indicate it.

In the proposal for this project, it was suggested that the unknown variables in water-, salt- and isotope balances can be eliminated if balances are drawn up for a sufficient number of times.

Table 5.2: Flow-, concentration- and Sr-ratio data for 5./6. December 1990.

INFLOW	Flow [cbm/d]	TDS [mg/l]	TDS [t/d]	Sr [mg/l]	Sr [kg/d]	Sr-87/Sr86	Sr-86 [mg/l]	Sr-86 [kg/d]	Sr-87 [kg/d]	Cl [mg/l]	Cl [kg/d]
LEC01		66		0.036	0.00					22	
H4M017	593 046	163	96.67	0.083	49.22	0.716595	0.04835	28.67	20.55	56	33 211
H4M018	104	2954	0.31	1.724	0.18					1 173	122
H4M019	3 602	2255	8.12	1.428	5.14	0.717803	0.83129	2.99	2.15	952	3 429
H4H011	100	4023	0.40	1.333	0.13	0.716881	0.77641	0.08	0.06	1 693	169
H3H011	19 562	2182	42.68	0.880	17.21					920	17 997
				Mean:	0.717093						
Total	616 414		148.18		71.89		1.65605	31.75	22.75		54 928
OUTFLOW											
Angora C.	49 375	285	14.07	0.149	7.36	0.717141	0.08677	4.28	3.07	107	5 283
Sanddrift	127 914	358	45.79	0.188	24.05	0.717141	0.10948	14.00	10.04	121	15 478
H5M004	57 622	1002	57.74	0.394	22.70	0.717141	0.22945	13.22	9.48	389	22 415
LOSS	381 503		30.58		17.79	0.659178		0.24	0.16		98 104
%	61.89%		20.64%		24.74%			0.74%	0.68%		178.60%
*) values in italics are estimates											

It seems that there are so many unknown or inaccurate parameters, that this is not possible. Balance calculations for different variables (in the example in Table 5.2 for December 1990) show variations in the loss percentage between 20,64% for TDS and 24,74% for Sr. Although the calculated percentages still agree closely, the difference of 4,1% corresponds to a volume of over 25 000 m³/d for the total inflow. The resulting strontium ratio signals that considerable errors must be hidden in the input values.

¹ Walraven has found that Sr-ratios of surface- and ground water are different and that irrigation return flow has retained its surface water ratio. The question remains whether return flow has still the same ratio by the time it reaches the river. If return flow does not adopt the strontium signature of the soil/aquifer it travels through, then why does the rain water which recharges the aquifers attain the TMS- or Bokkeveld ratio of the aquifer? Has a new equilibrium be established along the return flow paths?

Flügel has not published the values he used for the different parameters in his balance calculations or their source. He finds water losses in the months where the total flow is at its lowest (Flügel, 1990, Tab. 1), but where the influence of ground-water inflow should be most evident and vice versa. This indicates that other more important factors have not been fully taken into account for. Before salt denudation has not been accounted for, it seems not correct to ascribe the gains in the salt balance to saline ground water.

The figures reported by Flügel for the hydrological year 1987/88 (Flügel, 1990, Tab. 1) indicate a mean daily gain of 135583 m³ water and 54814 kg salt. This corresponds to a concentration of 404 mg/l and does not support the deduction of saline ground-water inflow.

Irrigation return flow is one of the components about which there is still much uncertainty. Petra Lautner (1989) has investigated irrigation return flow near Robertson between November 1988 and February 1989. The 17 drains monitored (cf. Table 3.1) received return flow from lands under different crops and were irrigated by different techniques.

At one station (46), water from a different source was probably found and at five other stations (7, 9, 26, 50 and 65) only part of the return flow was collected. If the data from these six drains are disregarded, the salt output is 29,6% higher than the input. The average salt gain for the different stations varies between -77% and +1229% with a mean gain of 230% for the 11 stations. The great variability of the data causes considerable doubt regarding the representativeness of the results.

The leaching fraction, i.e., the percentage of irrigated water appearing as return flow, was determined at 9,6% for all 17 drains and at 15,0% without the above six drains.

If Lautner's assumptions are correct, the daily water requirements for the area are $\approx 3572 \text{ ha} \cdot 34 \text{ m}^3/\text{d}/\text{ha}$, i.e., 121 448 m³/d which produce $\approx 10\%$ irrigation return flow, i.e., 12 145 m³/d.

Murray, Biesenbach and Badenhorst (1989) investigated land use, crops, irrigation methods and water- and salt movement in an area along the Robertson Canal. They used the IRRISS model to determine the various components in a water- and salt balance for a 260-day period in the irrigation period 1986/87. They found the return flow from canal- and dam-seepage losses for the area served by the Robertson Canal to be 26,75%. Irrigation return flow alone amounted to 11,28% (cf. Table 3.3).

Return flow salinities were of the same order as those expected. This has been achieved by introducing a quantity *Salt flux in the delivery zone* (item 18 in Table 17 of that report) which accounts for 2/3 of the *Return load from irrigated soil*. However, calibration is necessary, because flow paths and interaction with ground water are unknown and because the modelling depends largely on the chosen input parameters.

From the foregoing, it is evident that the processes which contribute to the salinisation are well-understood, but that it is still difficult to quantify the amounts of salt derived from the different sources.

From a run of the DISA model for the period June 1985 to April 1986, irrigation return flow can be calculated as between 57 330 000 m³/season without or 74 991 000 m³/season including canal losses (cf. Table 3.3). This is equivalent to a mean return flow of 16,5 to 21,6%.

The DISA model has overcome some of the problems of IRRISS, but it requires water- and salt contribution of the ground water as input.

Table 5.3: Mean concentrations of ground-water components for five aquifers as a function of their mean strontium concentrations.

Source	Enon	Witteberg	Bokkeveld	TMS	Malmesbury	B'vid./TMS	MEAN	Std. dev.	%
EC	398	137	584	189	128	3.1	377	0.53	
TDS	2785	1017	3965	1439	940	2.8	2630	0.50	
Na	766	167	1111	274	158	4.1	700	0.61	
K	20.4	1.9	23.7	40.8	9.6	0.6	19.0	0.78	
Ca	66	83	91	77	83	1.2	77	0.13	
Mg	104	43	147	43	31	3.4	98	0.51	
M.Aik	79	264	263	244	232	1.1	152	0.51	
Cl	1576	255	1971	444	255	4.4	1371	0.59	
SO ₄	153	118	282	124	94	2.3	167	0.45	
F	1.6	0.7	2.2	4.3	0.8	0.5	1.6	0.90	
NO ₃ -N	0.2	1.6	2.3	3.9	2.9	0.6	1.1	1.27	
NO ₂ -N	0.1	0.1	0.2	0.2	0.0	1.1	0.1	0.55	
Al	0.027	0.172	0.171	0.807	0.119	0.2	0.094	3.33	
Ba	0.011	0.047	0.084	2.624	0.059	0.0	0.090	12.82	
B	0.338	0.112	0.555	0.124	0.059	4.5	0.321	0.64	
Br	4.573	0.896	5.966	1.269	0.681	4.7	4.021	0.60	
Cu	0.009	0.044	0.024	0.180	0.034	0.1	0.022	3.14	
Fe	2.064	0.953	1.074	4.016	2.371	0.3	1.973	0.63	
Mn	0.306	0.204	0.489	2.699	0.268	0.2	0.384	2.79	
PO ₄	0.478	0.000	0.835	0.127	17.028	6.6	2.773	2.69	
Si	1.074	17.702	9.798	113.021	12.258	0.1	7.991	5.80	
Sr	1	1	1	1	1	1.0	1	0.00	
Zn	0.129	0.388	0.132	1.040	0.339	0.1	0.207	1.81	

The strontium isotope investigation of the present study has indicated that the outflow observed at H5M004 in December 1990 consists of approximately one part of strontium, with the mean strontium ratio of ground water and 14 parts with the ratio determined for run-off at H4M017. It was shown that this one part is equivalent to about 34% of TMS- or less than 3% of Bokkeveld water. This represents a contribution of about 19 500 m³/d from the Table Mountain Sandstone Aquifer or less than 1 600 m³/d of Bokkeveld water. So far, canal exports have not been taken into account. If export occurred at full canal capacity of 2,55 l/s (see Table 3.3), the total ground-water contributions change to ~ 80 000 m³/d from TMS or ~ 6 500 m³/d from Bokkeveld.

Depending on the chosen strontium concentration, ground-water flow volumes vary greatly. The imported corresponding salt mass changes to a much lesser degree. In Table 5.3, the mean concentrations of the various components as given in Table 3.6 are divided by the respective strontium concentrations. While the mean strontium ratios for all samples of TMS and Bokkeveld vary by a factor of ≈ 7 , the corresponding salt concentrations vary less, often by a factor not greater than 2,5 (NB: A factor of ≈ 12 determined for the December 1990 samples was used for the calculations of the ground-water flow volumes). The relation of TDS for Bokkeveld and TMS, for instance, is $3965/1439 = 2,8$ and for alkalinity $263/244 = 1,1$. An estimate of the total salt load from in-flowing ground water is, therefore, more accurate than the calculated flow itself.

On the basis of the re-evaluation of pumping test data and the resulting transmissivity $T \approx 5 \text{ m}^2/\text{d}$, a ground-water flow rate of $4\,000 \text{ m}^3/\text{d}$ was obtained. This quantity did not include TMS ground water circulating on deep-seated faults and fractures.

Analyses of ^2H - and ^{18}O -ratios of surface-water samples taken in December 1990 show an enrichment of both ratios between H4M017 and H5M004 from -2.0 to -1.6 and from -13 to -10 respectively. This is despite the fact that water of the tributaries has lower ratios than the Breede River at H4M017 (see Tables 3.9 and 3.10). Any lowering of the stable isotope ratios due to the inflow of ground water has therefore been masked by evapotranspiration which is very high at this time of the year. However, any substantial inflow of ground water with its considerably lower isotope rates, i.e., in the order of 34% of the flow at H5M004, appears unlikely.

6. SUMMARY

Research on salinisation problems in the Middle Breede River Valley carried out over the last two decades has investigated a large number of variables that (may) contribute to the salt load of the river. Often the same aspects have been looked at in a different context, at different localities or different times and by different researchers and it has become difficult to keep track with all the results obtained.

The original approach to this study was to balance the various variables. It was therefore necessary to consider all sources and phenomena that may affect the salt load of the Breede River. For this purpose, it was deemed necessary to consolidate all geohydrology related aspects.

Inherent problems with the sufficiently accurate quantification of various components in the water balance and salt balance have led to the abortion of this approach.

Ground water is mainly recharged in the mountains where the rainfall is up to a factor eight higher than in the valley. It flows mainly along faults, joints and fractures towards the Breede River. The aquifer is effluent. Water-level gradients change little during the year and ground-water flow towards the river is relatively constant.

Salt present, *inter alia* in the Bokkeveld formations, is dissolved. Salinisation of ground water may be high in the matrix and in small fissures, but is small along highly permeable pathways where the salt has already been removed from the walls. Water from high yielding holes in salt-bearing formations is generally of a much better quality than from weak or "dry" ones.

Other processes producing saline water are:

- (i) Irrigation return flow appears to be the most important source. Quantities of between ≈ 5 and $11 \text{ m}^3/\text{ha}\cdot\text{d}$ with a leaching rate about 15 to 18 $\text{kg}/\text{ha}\cdot\text{d}$ are reported.
- (ii) Gypsum and fertiliser application.
- (iii) Dissolution of salt from newly developed fields. Up to 0,58‰ salt has been found in Bokkeveld rocks.
- (iv) Concentration of salts through evaporation ($\approx 1700 \text{ mm/a}$).

The investigation was aimed at the ground-water contribution to the salt load in the Breede River.

6.1 OBJECTIVES

1. Determine whether part of the salt load in the Breede River is derived from ground water discharging from underlying and adjoining aquifers of the Nama Group, the Cape Supergroup and possibly the Karoo Sequence, by means of an investigation into the spatial distribution and concentration of natural isotopes and chemical tracers in aquifers beneath and along the Breede River.
2. Determine applicability and feasibility of using chemical tracers for pollution- and water-balance studies.

The first of the stated objectives has been interpreted as aiming at the quantitative rather than the qualitative answer to the problem of salinisation of the Breede River.

Quantification of the river recharge through ground water by means of ^2H and ^{18}O balance methods appears no longer feasible because of the following reasons:

- i) The ground-water component in the river water appears relatively small. Error margins of the other components in the system, for instance (a) return flow- and run-off volumes or (b) representative salinities of return flow- and ground water are comparatively large.
- ii) Changes in the ^2H and ^{18}O isotope ratios of return flow caused by evapotranspiration and the effect this has on the run-off in the Breede River are not quantifiable.

A large number of individual components determine the resulting flow and salt load at the lower end of the research area. These chemical- and stable isotope in- and outputs are not only variable in space and time, but they are also influenced by processes such as variable evapotranspiration and activities of man, e.g., gypsum- and fertiliser application or development of new irrigation areas. Unique chemical tracers for the individual components (which do not interact with each other) have not been found. Unless considerable simplification is tolerated, balancing by means of chemical and/or ^2H - and ^{18}O -ratios can also not yield answers with the required accuracy.

Strontium-ratio analyses had not been conceived as a method to provide information about the question of ground-water contribution to river run-off and salinisation and had, of course, not been budgeted for. It was the merit of Dr. Walraven not only to draw the attention of the Steering Committee to this method, but also to carry out a number of these work-intensive analyses.

Strontium-ratio analyses proved to be a good indicator of the origin of the water: ground water had a noticeable higher ratio than surface water and processes at the surface and in the alluvium seemed not to alter the ratio of the applied irrigation water.

By using these analyses, it was possible to quantify the ground-water contribution to the run-off in the Breede River. Re-evaluation of pumping test data seems to confirm the answers obtained from the strontium-ratio analyses.

The answers to the two objectives are:

1. Approximately 6% of 11,5 kg strontium contained in the run-off at Secunda on 6 December 1990 was derived from ground water. This represents slightly less than 2% or $\pm 2000 \text{ m}^3/\text{d}$ of water with a strontium concentration typical for Bokkeveld (or 34% of Table Mountain Sandstone water). Assuming maximum canal exports, the total ground-water inflow is approximately $6500 \text{ m}^3/\text{d}$ of Bokkeveld- or $80000 \text{ m}^3/\text{d}$ of Table Mountain Sandstone water.

Pumping test analyses indicated a ground-water flow rate of $\pm 4000 \text{ m}^3/\text{d}$, excluding TMS water rising along deep faults or fractures.

Deuterium analyses indicated small, not quantifiable contributions from ground water.

2. Strontium isotope ratios can be used for balance studies, if the input waters are sufficiently different and are not submitted along their flow paths to the influence of strontium with different isotope ratios.

6.2 CONCLUSIONS

It is felt that the mean value of the strontium ratios from seven ground-water samples is rather representative. The contribution of ground water to the flow in the Breede River is, however, also based on the comparatively small difference in the strontium ratio of one sample each from H4M017 and H5M004. It seems advisable to collect further samples for strontium-ratio analyses at these two weirs during low-flow conditions. A better populated data base will assure a more representative figure for the calculated ground-water contribution. Based on the strontium ratios, a relation between ground water and run-off at H5M004 equal to $\frac{1}{15}$ was calculated in this study.

Independent from the strontium study, a relatively low ground-water flow rate of approximately $4000 \text{ m}^3/\text{d}$ has been obtained after pumping tests carried out under Greeff and Jolly were re-evaluated.

Maximum irrigation and consequently irrigation return flow occur near the lower end of the study area; this is also the stretch of the Breede River where salination is increasing most rapidly. From the geological disposition, one would expect that the effect of in-flowing salty ground water should be more evenly spread. This strengthens the conception that ground water of a high salt content does not enter the Breede River in appreciable amounts.

Increased flows along major faults or fractures of relatively fresh ground water from the TMS seem, however, possible, although ^2H - and ^{18}O -ratios do not indicate this. Salt dissolution along preferential pathways in the Bokkeveld is the only explanation why strong boreholes in this formation yield better water than low-yielding and dry holes. Freshening of new holes during pumping has been described by Greeff.

Observed water levels changed little during the year. This indicates a considerable residence time of the water in the aquifer before it reaches the vicinity of the Breede River. With distances of 10 to 30 km between the river and the main recharge areas, any observed water-level variations will rather reflect seasonal variations in the abstraction rate rather than a response to aquifer recharge.

In general, ground waters occurring in the area are significantly different from one another and can be classified through their chemical composition. Likewise, the different aquifers exhibit typical deuterium and oxygen-18 characteristics which allow their qualitative distinction from each other and from surface waters.

Much effort went into improving weak data, although the envisaged mass-balance calculation did not yield the expected results. Running this investigation concurrently with the Breede River Salination Research Program of the HRI would have provided more data and better data control. Praise of the Water Affairs BRSRP team who ran the program for three years, appears well suited. Good data control during data capturing is essential and their personnel proved to be qualified, experienced and dedicated.

6.3 RECOMMENDATIONS

One sample, each at H4M017 (inflow), H5M004 (outflow), irrigation water and return flow at the same site should be taken for strontium ratio determination once or twice during the dry season. This will ensure a more representative figure for the calculated ground-water contribution which is presently based on one set of samples only.

The strontium isotope ratio method is a new technique with considerable potential. For the investigation of areas with similar problems, it seems superior to other approaches and should be further tested for its applicability.

Where water conductivity- and chemical quality surveys are carried out, parameter values should be determined from representative samples taken, e.g., after sufficiently long pumping of holes rather than from samples bailed because stratification of water occurs in many boreholes. Adherence to the ground-water sampling guide by Weaver (1992) and concerning stratified aquifers, especially the adherence to the procedures of purging holes described in Chapter 12, are recommended.

REFERENCES

- Anonymous, undated.- The Feasibility of Determining the Contribution of Different Water Sources to the Salinization of the Breede River by Isotope- and Chemical Characterization. Report of the Institute for Ground-water Studies to the Water Research Commission in January 1991.
- Anonymous, 1986.- Water Resources of the Republic of South Africa. Department of Water Affairs.
- Bertram, E., 1989.- Die verband tussen geologie, grondwatergehalte en boorgatlewering in die Breederiviervallei tussen die Groter Brandvleidam en die Sanddrift-meetwal. Department of Water Affairs, Directorate Geohydrology, Technical Report No. GH 3651.
- Beuster, J., Görgens, A.H.M. & Greyling, A.J., 1990.- Breede River System: Development of a Daily Hydrosalinity Model (DISA). DWA Report No. H000/00/0790.
- Braune, E., 1988.- Progress Report 1987/1988. HRI, Department of Water Affairs.
- Craig, H., 1961.- Isotopic Variations in Meteoric Waters. *Science*, vol. 133, p. 1702 - 1703.
- Craig, H., 1963.- The isotopic geochemistry of water and carbon in geothermal areas. In *Nuclear geology in geothermal areas*. p. 17-53. Pisa, CNR - Laboratorio di Geologica Nucleare.
- Ehhalt, D., K. Knott, J.F. Nagel & J.C. Vogel, 1963.- Deuterium and oxygen-18 in rain water. *J. Geophys. Res.*, 68, p. 3775 - 3780.
- Flügel, W.A., 1989(b).- Groundwater dynamics influenced by irrigation and associated problems of river salination; Breede River, Western Cape Province, RSA.- Groundwater Contamination IAHS Publication No. 185, p. 137-145.
- Flügel, W.A., 1989(c).- Studies of Shallow Groundwater Dynamics for Salinity Research in the Breede River Valley, Western Cape Province, RSA. Fourth South African National Hydrological Symposium, Pretoria, p. 400 - 408.
- Flügel, W.A., 1990.- Breede River Salination Research Program. 4. Internal Report: Annual water and salt balances as a means to estimate the contribution of groundwater seepage to the Breede river salination. Dept. of Water Affairs, HRI Report NH00//GIQ0290.

- Flügel, W.A. & G. Howard, 1987(b).- Water balance, groundwater and return flow salinity of a semi-arid irrigation scheme in the Breede River Valley, Western Cape Province. HRI File N3/2020/04-GH, Department of Water Affairs.
- Forster, S.F., 1989.- Operational and planning alternatives. Unpublished Report in: Coordinating Committee for Salinity Research, Meeting on 24. 4. 1989.
- Fourie, J.M., 1976.- Mineralization of Western Cape Rivers. Ph.D.-thesis. Unpublished, 147 p.
- Friedman, I, A.C. Redfield, B. Schoen & J. Harris, 1964.-Deuterium Content of Natural Water and other Substances. *Geoch. et Cosmoch. Acta*, 4, p. 89 - 103.
- Gat, J.R., & Y. Tzur, 1967.- Modification of the isotopic composition of rainwater by processes which occur before groundwater recharge. In: *Isotopes in Hydrology*, p. 49 - 60, Vienna, IAEA.
- Greeff, G.J., 1978.- Geohidrologie van die Breëriviervallei tussen Brandvleidam en Robertson.- Tegnieuse Verslag No 2991, Departement van Waterwese, Pretoria.
- Greeff, G.J., 1979.- Geohidrologie van die Breëriviervallei tussen Brandvlei en Robertson. Vorderingsverslag No. 11: Verslag oor die Tritiuminhoud van die Grondwater, met Afleidings. Unpublished, 6 p.
- Greeff, G.J., 1990.- Detailed Geohydrological investigations in the Poesjesnels River Catchment in the Breede River Valley with Special Reference to Mineralization. Water Research Commission Report 120/1/90.
- Greeff, G.J., 1991.- The Geology of a typical catchment in the Cape Supergroup, Breë River Valley. Dissertation, University of Stellenbosch.
- Howard, G.J., 1986.- A Report on Initial Fieldwork Concerning the Salination of the Breede River. Report No, HRI 86/5, Hydrological Research Institute, Department of Water Affairs.
- Jolly, J.L., 1990.- The Groundwater contribution to the salt load and flow volume of the Breede River in the Robertson area. Department of Water Affairs, GH Report 3683.
- Kienzle, Stefan, 1989(a).- Breede River Salination Program. 3. Internal Report. Summary of daily data for the hydrological year 1987/88. HRI Report NH000//RIQ0589.
- Kienzle, Stefan, 1990.- Breede River Salination Program. 5. Internal Report. Summary of daily data for the hydrological year 1988/89. HRI Report NH000//RIQ0390.
- Kienzle, S. & Flügel, W.-A., 1988.- Breede River Salinity Research Program, 1. Internal Report : The Salinity of the Breede River and its Tributaries between Brandvlei

- Dam and H5M04 : Summary of Daily Data up to September 1987. HRI Report NH000//RIQ0888.
- Lautner, P., 1989.- Salt and Water Balance of 17 Drains and Tributaries of the Breede River. Unpubl. Report. Hydrological Research Institute, Department of Water Affairs, Pretoria.
- Logan, J., 1964.- Estimating Transmissibility from Routine Production Tests of Waterwells. *Groundwater*, 2:1, p. 35-37.
- Lourens, U., Brown, B. & Seed, A., 1987.- Mapping the Extent of Irrigated Land in the Breede River Catchment with the aid of satellite imagery. Department of Water Affairs, HRI Report No N/H000?00?RIH/0387.
- Moolman, J.H., P.C. van Royen & Weber, H.W., 1983.- The effect of irrigation practices in the Breë River Valley on the salt content of a small river. *Irrigation Science*, Vol. 4, p. 103-116.
- Moolman, J.H., 1989.- Modelling of Processes Operating in the Root Zone - Factors to consider. In: Coordinating Committee for Salinity Research, Meeting on 24. 4. 1989.
- Moser & Stichler, 1970.- Deuterium Measurements on Snow Samples from the Alps. In: *Isotope Hydrology 1970*, p. 43 - 57, Vienna, IAEA.
- Murray, Biesenbach & Badenhorst, 1989.- A Pilot Study of the Irrigated Areas Served by the Breede River (Robertson) Irrigation Canal. WRC Report No. 184/1/89.
- Ninham Shand, 1985.- Report on a Situation Study of Irrigation Return Flow Quantity and Quality in River Basins with Extensive Irrigation Development in South Africa. Report to the Water Research Commission No. 943/4061.
- Vogel, J.C., D. Ehhalt & W. Roether, 1963.- A Survey of the Natural Isotopes of Water in South Africa. In: Proceedings of the Symposium on the Application of Radioisotopes in Hydrology, Tokyo, 5 - 9 March 1963. International Atomic Energy Agency, Vienna.
- Volkman, S., 1990.- Probleme der Bodenversalzung in semi-ariden Klimaten - am Beispiel des Breede-Flusses, Westliche Kap-Provinz, Republik Südafrika. Dissertation Universität Bonn.
- Volkman, S. & W.-A. Flügel, 1988.- Breede River Salination Research Program. 2. Internal Report: Soil Salination and Associated Shallow Groundwater Dynamics of the Alluvial Robertson Irrigation Scheme, Breede River Valley, Western Cape Province. Dept. of Water Affairs, HRI Report N/H400//GIQ/1088.

- Wittingham, J.K., 1976.- Preliminary Geohydrological Survey in the Breede River Valley, Worcester District, C.P., GH 2883.
- Weaver, J.M.C, 1992.- Groundwater Sampling. Water Research Commission Project No. 339, TT 54/92, Pretoria.
- Woodcock, A.H. & I. Friedman, 1963.- The deuterium content of raindrops. *J. Geophys. Res.*, 68, p. 4477 - 4483.

Appendix 1

List of Sites, Site names and Site types

 Data from file BASICINF :

SITE_ID_NR	NR_ON_MAP	SITE_NAME	SITE_TYPE
3319CD00003	00003	ELANDIA	Borehole
3319CD00004	00004	GOEDENGED	Borehole
3319CD00005	00005	GOEDENGED	Borehole
3319CD00007	00007	LIBERTAS	Borehole
3319CD00012	00012	RADYN	Borehole
3319CD00013	00013		Borehole
3319CD00014	00014	VILLIERSDORP	Borehole
3319CD00015	00015	VILLIERSDORP	Borehole
3319CD00017	00017	VILLIERSDORP	Borehole
3319DD00112	AA	DE HEX RIVIER, opposite well	Fountain
3319DC00107	AB	GNOEM GNOEMS	Fountain
3319DD00115	AC	DE HOOP	Borehole
3319DD00116	AD	DE HOOP	Borehole
3319DD00114	AE	ROODE HOOGTE, drain opp. Swanepoels homestead	Tunnel, shaft or drain
3319DD00127	AF	VROLYKHEID, near Konings River.	Borehole
3319DD00117	AG	GOEDE MOED, at main road	River or stream
3319DD00131	ANG01	ANGORA CANAL	Canal or trench
3319DD00109	B5	DOORN KLOOF, Vrolijkheid Nature Reserve	Borehole
3319DC00104	B7	DE FONTEIN, 200 m NW of homestead Mr. Theart	Borehole
3319DD00028	BI01	BOVLEI	Borehole
3319DD00029	BI02	BOVLEI	Borehole
3319CB00101	BV	BRANDVLEI DAM, near pumping station	Fan or dam
3319CD00102	C2	RIVIERPLAAS, Canal below Kwaggaskloof Dam	Canal or trench
3319DD00030	CD01	CLARIS WOLD - LE CHASSEUR	Borehole
3319DD00124	CD1A	LAUGHING WATERS, (ca. 5 m E of switchboard).	Borehole
3319DD00031	DE01	DE GORREE - HIGHLANDS FARMS	Borehole
3319CD00023	DI01	DE RISJES VALLEI - HIGHLANDS	Borehole
3319CD00024	DI02	DE RISJES VALLEI - HIGHLANDS	Borehole
3319DC00009	DK01	DE HOEK: GOOD HOPE	Borehole
3319DC00001	DN01	DE FONTEIN	Borehole
3319DC00002	DN02	DE FONTEIN, 200 m S homestead of Mr. Jooste	Borehole
3319DC00003	DN03	DE FONTEIN	Borehole
3319DC00004	DN04	DE FONTEIN	Borehole
3319DC00005	DN05	DE FONTEIN	Borehole
3319DC00006	DN06	DE FONTEIN, +/- 400 m W Thearts homestead	Borehole
3319DC00112	DN06A	DE FONTEIN, 60 m downstream of DN06	Fountain
3319DC00007	DN07	DE FONTEIN, Agterkliphoopte Wynkelder	Borehole
3319DC00117	DN07A	DE FONTEIN, Agterkliphoopte, next reservoir	Borehole
3319DC00118	DN07B	DE FONTEIN, Agterkliphoopte, S of cellar	Borehole
3319DC00008	DN08	DE FONTEIN: BELLEVUE	Borehole
3319DB00001	DP01	KEURKLOOF	Borehole
3319DB00002	DP02	KEURKLOOF	Borehole
3319DB00003	DP03	KEURKLOOF	Borehole
3319DD00045	DP04	DE HOOP - KEURKLOOF	Borehole
3319DD00046	DP05	DE HOOP - KEURKLOOF	Borehole
3319DD00047	DP06	DE HOOP	Borehole
3319DD00048	DP07	DE HOOP	Borehole
3319DD00049	DP08	DE HOOP	Borehole
3319DD00050	DP09	DE HOOP, Mon Desir, Mr. Burger	Borehole
3319DD00032	DR01	DE HEX RIVIER - BLOEKOMHOF	Borehole
3319CD00020	DS01	DE DOORNS - HAMMANSHOF	Borehole
3319CD00018	DS02	DE DOORNS - MORESON	Borehole
3319CD00021	DS03	DE DOORNS - BELLEVUE	Borehole
3319CD00022	DS04	DE DOORNS - BELLEVUE	Borehole
3319CD00036	EN05	RATELFONTEIN - HELDERSTROOM	Borehole
3319DB00102	F1	NOREE, Fountain in Smitskloof	Fountain
3319CD00002	G10652	BELLEVUE	Borehole
3319CD00010	G17848	MISPA	Borehole
3319CD00006	G22204	LIBERTAS	Borehole
3319CD00011	G24398	MISPA	Borehole
3319CD00008	G28239	LIBERTAS	Borehole
3319CD00009	G28265	LIBERTAS	Borehole
3319CB00001	G30909	GLASGON	Borehole
3319CB00002	G30937	BOONTJIESRIVIER	Borehole
3319CB00003	G30955	DEMOND	Borehole
3319CB00004	G30956	DEGROOTVLAKTE	Borehole

3319CB00005	G30957	DE WAAIHOEK	Borehole
3319CB00006	G30957B	DE WAAIHOEK	Borehole
3319CB00007	G30958	WYSERDRIFT	Borehole
3319CB00008	G30958B	WYSERDRIFT	Borehole
3319CB00009	G30959	LILLEPLAAS	Borehole
3319CB00027	G30960	LILLEPLAAS	Borehole
3319CB00010	G30961	LILLEPLAAS	Borehole
3319CB00011	G30963	BORKEKRAAL	Borehole
3319CB00012	G30985	SERVEDE	Borehole
3319CB00013	G30986	HARTEBEESTRIVIER	Borehole
3319CB00014	G31000	HARTEBEESTRIVIER	Borehole
3319CB00015	G31008	ONDERPLAAS	Borehole
3319CB00016	G31009	WYSERDRIFT	Borehole
3319CB00017	G31009B	WYSERDRIFT	Borehole
3319CB00018	G31010	WYSERDRIFT	Borehole
3319CB00019	G31010B	WYSERDRIFT	Borehole
3319CB00020	G31010G	WYSERDRIFT	Borehole
3319CB00021	G31255	WYSERDRIFT	Borehole
3319CB00022	G31255B	WYSERDRIFT	Borehole
3319CB00023	G31255C	WYSERDRIFT	Borehole
3319CB00024	G31256	KENTUCKY	Borehole
3319CB00025	G31257	SWASTIKA	Borehole
3319CB00026	G31257B	SWASTIKA	Borehole
3319DD00001	G33570	OVER HET ROODEZAND 112	Borehole
3319DD00002	G33571	OVER HET ROODEZAND 112	Borehole
3319DD00003	G33571A	OVER HET ROODEZAND 112	Borehole
3319DD00004	G33572	GOEDE MOED 128	Borehole
3319DD02572	G33572A		Borehole
3319DD00005	G33573	OVER HET ROODEZAND 112	Borehole
3319DD02573	G33573A		Borehole
3319DD00006	G33574	GOEDE MOED 128	Borehole
3319DD02574	G33574A		Borehole
3319DD04574	G33574C		Borehole
3319DD00007	G33575	GOEDE MOED 128	Borehole
3319DD02575	G33575A		Borehole
3319DD00008	G33576	GOEDE MOED 128	Borehole
3319DD02576	G33576A		Borehole
3319DD00009	G33577	GOEDE MOED 128	Borehole
3319DD00010	G33578	GOEDE MOED 128	Borehole
3319DD00011	G33579	UITNOOD 129	Borehole
3319DD00012	G33580	UITNOOD 129	Borehole
3319DD00013	G33581	OVER HET ROODEZAND 112	Borehole
3319DD00014	G33582	OVER HET ROODEZAND 112	Borehole
3319DD00015	G33583	OVER HET ROODEZAND 112	Borehole
3319DD02583	G33583A		Borehole
3319DD00016	G33584	OVER HET ROODEZAND 112	Borehole
3319DD02584	G33584A		Borehole
3319DD04584	G33584C		Borehole
3319DD00017	G33585	RIET VALLEI 115	Borehole
3319DD02585	G33585A		Borehole
3319DD00018	G33586	GOEDE MOED 128	Borehole
3319DD00019	G33587	BAKENSHOOGTE 114	Borehole
3319DD00020	G33588	UITNOOD 129	Borehole
3319DD00021	G33589	GOEDE MOED 128	Borehole
3319DD00022	G33590	OVER HET ROODEZAND 112	Borehole
3319DD02590	G33590A		Borehole
3319DD00023	G33591	OVER HET ROODEZAND 112	Borehole
3319DD02591	G33591A		Borehole
3319DD03591	G33591B		Borehole
3319DD00024	G33592	OVER HET ROODEZAND 112	Borehole
3319DD02592	G33592A		Borehole
3319DD01593	G33593		Borehole
3319DD01594	G33594		Borehole
3319DD01595	G33595		Borehole
3319DD01596	G33596		Borehole
3319DD02596	G33596A		Borehole
3319DD02597	G33597X		Borehole
3319DD01598	G33598		Borehole
3319DD01599	G33599		Borehole
3319DD01600	G33600		Borehole
3319DD04600	G33600C		Borehole
3319DD01601	G33601		Borehole

3319DD01602	G33602	Borehole
3319DD01603	G33603	Borehole
3319DD01605	G33605	Borehole
3319DD01606	G33606	Borehole
3319DD01607	G33607	Borehole
3319DD01608	G33608	Borehole
3319DD01609	G33609	Borehole
3319DD01610	G33610	Borehole
3319DD01611	G33611	Borehole
3319DD00033	GE01	GOREE'S HOOGTE - MADEBA
3319DD00034	GE02	GOREE'S HOOGTE - MADEBA
3319DB00103	H	NOREE, Fountain in Knypkloof
3319CB00100	H1R01Y	BREEDERIVER, Nieuwedrifbrug
3320CC00102	H3M11	WEIR H3M11 in Kogmanskloof River
3319DD00119	H4M11	KEISERS RIVER, Uitnood, at road bridge
3319DD00108	H4M16	MCGREGOR, WEIR H4M16 in Keisers River
3319DC00102	H4M17	LE CHASSEUR, WEIR H4M17 in Breë River
3319DC00101	H4M18	CLARISWOLD, WEIR H4M18 in Poëjesnela River
3319DD00106	H4M19	DE GOREE, WEIR H4M19 in Vink River
3319CD00101	H4R04U	RIVIERPLAAS, Outlet Kwaggeskloof Dam
3320CC00101	H5M04	WOLVENDRIPT, WEIR H5M04 at Secunda
3319CD00025	HE01	HERMITAGE
3319DD000126	HOOPS	ROBERTSON, at railway bridge.
3319CD00026	JF01	JASONKLOOF
3319CD00027	JF02	JASONKLOOF
3319CD00028	JF03	JASONKLOOF
3319DB00104	K	LA RENA
3319DB00005	KD01	KRUISPAD
3319DB00006	KD02	KRUISPAD
3319DB00007	KD03	KRUISPAD
3319DB00107	KD2A	KRUISPAD, 50 m NE KD02
3319DD00026	KG01	KLIPBERG - KONINGSRIVIER
3319DA00001	KH01	KLOPPERSBOSCH - GLEN OAK
3319CD00029	KN01	KLEINFONTEIN
3319CD00030	KN02	KLEINFONTEIN
3319CD00031	KN03	KLEINFONTEIN
3319DD00035	KR01	KLAAS VOOGDS RIVIER - CONCORDIA
3319DB00105	L	LA RENA, "Volstruisnes", Langkloof
3319DD00118	LE01	LA COLLINE, fountain on Skurwekop
3319DC00113	LEC01	LE CHASSEUR CANAL, 1 km below off-take
3319DC00114	LEC02	LE CHASSEUR CANAL, at Clariswold
3319DB00106	M	LA RENA, 60m E "Volstruisnes".
3319DA00103	MCG	BOVEN KLOPPERBOSCH
3319DD00036	MD01	MC GREGOR TOEKENNINGSGBIED - HOUTBAAI
3319DD00037	MD02	MC GREGOR TOEKENNINGSGBIED -VOOR-DIE-BERG
3319DD00038	MD03	MC GREGOR TOEKENNINGSGBIED - PAYNESDALE
3319DD00039	MD04	MC GREGOR TOEKENNINGSGBIED - PAYNESDALE
3319DD00040	MD05	MC GREGOR TOEKENNINGSGBIED - PAYNESDALE
3319DD00041	MD06	MC GREGOR TOEKENNINGSGBIED - PAYNESDALE
3319DD00042	MD07	MCGREGOR, Uitvlug, on right bank of Hoekriver
3319DD00043	MD08	MC GREGOR TOEKENNINGSGBIED - RHEBOKSKRAAL
3319DD00025	MD09	MC GREGOR TOEKENNINGSGBIED - RHEBOKSKRAAL
3319DB00018	MG01	MIDDELBURG
3319DD00125	N	DIE GHWARRIES, ca. 30 m W of ruin.
3319DB00013	NE01	NOREE, Appelkoosboort
3319DB00012	NE02	NOREE, Huispomp
3319DB00011	NE03	NOREE, Volkshuis pomp
3319DB00010	NE04	NOREE
3319DB00009	NE05	NOREE
3319DB00004	NE06	NOREE
3319DB00008	NE07	NOREE
3319DB00016	NE08	BUITENSTEKLOOF
3319DB00014	NE09	BUITENSTEKLOOF
3319DB00015	NE10	BUITENSTEKLOOF
3319DB00017	NE11	LA RENA
3319DD00113	NELS	NELS RIVER, at main road bridge Robertson
3319DA00002	NG01	KLOPPERSBOSCH - NAUDES BERG
3319DA00003	NG02	NAUDES BERG - KLOPPERSBOSCH
3319DA00004	NG03	NAUDES BERG - KLOPPERSBOSCH
3319DA00005	NG04	NAUDES BERG - KLOPPERSBOSCH
3319DA00006	NG05	NAUDES BERG - KLOPPERSBOSCH
3319DA00007	NG06	NAUDES BERG - KLOPPERSBOSCH

3319DA00104	NGF	NAUDES BERG	Fountain
3319DC00115	O	POESJENELSRIVIER, Good Hope	Fountain
3319DD00120	P	ZAND BERG FONTEIN	Borehole
3319DC00010	PR01	POESJENELSRIVIER: GOODHOPE	Borehole
3319DC00011	PR02	POESJENELSRIVIER: DIE HOEK	Borehole
3319DC00012	PR03	POESJENELSRIVIER: DIE HOEK	Borehole
3319DC00013	PR04	POESJENELSRIVIER: DIE HOEK	Borehole
3319DC00014	PR05	POESJENELSRIVIER: DIE HOEK	Borehole
3319DC00015	PR06	POESJENELSRIVIER: DIE HOEK	Borehole
3319DC00016	PR07	POESJENELSRIVIER: DIE HOEK	Borehole
3319DC00017	PR08	POESJENELSRIVIER: DIE HOEK	Borehole
3319DC00018	PR09	POESJENELSRIVIER	Borehole
3319DC00019	PR10	POESJENELSRIVIER: MOUNTAIN VIEW	Borehole
3319DC00020	PR11	POESJENELSRIVIER: MOUNTAIN VIEW	Borehole
3319DC00021	PR12	POESJENELSRIVIER:MOUNTAIN VIEW	Borehole
3319DC00022	PR13	POESJENELSRIVIER:MOUNTAIN VIEW	Borehole
3319DC00023	PR14	POESJENELSRIVIER:VERGENOEG	Borehole
3319DC00024	PR15	POESJENELSRIVIER:SEWEFONTEIN	Borehole
3319DC00025	PR16	POESJENELSRIVIER:SEWEFONTEIN	Borehole
3319DC00026	PR17	POESJENELSRIVIER:SEWEFONTEIN	Borehole
3319DC00027	PR18	POESJENELSRIVIER:SEWEFONTEIN	Borehole
3319CD00019	PT01	PAULSGAT - HIGHLANDS	Borehole
3319DC00028	PY01	POESPAS VALLY:RETREAT	Borehole
3319DD00121	Q	Small holding of Mr. Lamprecht	Borehole
3319DD00122	R	Small holding of Mr. Lamprecht	Borehole
3319CB00102	R1	ONDER BRANDVLEI, Breë River at road bridge	River or stream
3319DD00105	R21	DE HEX RIVIER, Vink rivier at main road	River or stream
3319DA00101	R33	MIDDELBURG, Doringkloofspruit at road culvert	River or stream
3319DD00107	R35	NOREE, Dam 2 km upstream of Die Eike	Pan or dam
3319CB00200	RAIN STN.	WORCESTER, Rainfall Station 0022759 (TNK).	Meteorological station
3319DD00200	RAIN STN.	MCGREGOR, Rainfall Station 0023599 (Police).	Meteorological station
3319DD00201	RAIN STN.	ROBERTSON, Rainfall Station 0023678 (TNK).	Meteorological station
3319DD00202	RAIN STN.	ROBERTSON, Rainfall Station 0023678AW (SKL).	Meteorological station
3319DD00203	RAIN STN.	ROBERTSON, Rainfall Station 0023708X	Meteorological station
3319DD00051	RE01	DE HOOP, Croxley, above vineyard	Borehole
3319DD00052	RE02	DE HOOP, Croxley, BH below dam	Borehole
3319DD00053	RL01	RHEBOKSKRAAL	Borehole
3319DD00044	RL02	RHEBOKSKRAAL	Borehole
3319CD00032	RN01	RATELFONTEIN - EXELSIOR	Borehole
3319CD00033	RN02	RATELFONTEIN - THULAMANZI	Borehole
3319CD00034	RN03	RATELFONTEIN	Borehole
3319CD00035	RN04	RATELFONTEIN - HELDERSTROOM	Borehole
3319CD00037	RN06	RATELFONTEIN - LOUFONTEIN	Borehole
3319CD00038	RN07	RATELFONTEIN - LOUFONTEIN	Borehole
3319CD00039	RN08	RATELFONTEIN - LOUFONTEIN	Borehole
3319CD00040	RN09	RATELFONTEIN - EIKENHOF	Borehole
3319CD00041	RN10	RATELFONTEIN - MIDDELDRIJ	Borehole
3319CD00042	RN11	RATELFONTEIN - RATELFONTEIN-WES	Borehole
3319CD00043	RN12	RATELFONTEIN - RATELFONTEIN-WES	Borehole
3319CD00044	RN13	RATELFONTEIN - WAG- 'N-BIETJIE	Borehole
3319CD00045	RN14	RATELFONTEIN - WAG- 'N-BIETJIE	Borehole
3319CD00046	RN15	RATELFONTEIN - RIETSPRUIT	Borehole
3319CD00047	RN16	RATELFONTEIN - REANRA	Borehole
3319CD00048	RN17	RATELFONTEIN - GROENVLEI	Borehole
3319CD00049	RN18	RATELFONTEIN - GROENVLEI	Borehole
3319CD00050	RN19	RATELFONTEIN - DASBOS	Borehole
3319CD00051	RN20	RATELFONTEIN - DASBOS	Borehole
3319CD00052	RN21	RATELFONTEIN - FISMERSHOF	Borehole
3319CD00053	RN22	RATELFONTEIN - FISMERSHOF	Borehole
3319CD00054	RN23	RATELFONTEIN - UITSIG	Borehole
3319CD00055	RN24	RATELFONTEIN - UITSIG	Borehole
3319CD00056	RN25	RATELFONTEIN - WELTEVREDE	Borehole
3319CD00057	RN26	RATELFONTEIN - WELTEVREDE	Borehole
3319DD00128	ROB01	ROBERTSON CANAL	Canal or trench
3319DC00029	RV01	RIET VALLEY:KONINGSRIVIER	Borehole
3319DC00030	RY01	RIETVALLY:VREDENHOF	Borehole
3319DC00031	RY02	RIETVALLY:VREDENHOF	Borehole
3319DC00032	RY03	RIETVALLY:VREDENHOF	Borehole
3319DC00033	RY04	RIETVALLY:VREDENHOF	Borehole
3319DC00034	RY05	RIETVALLY:KASRA	Borehole
3319DC00035	RY06	RIETVALLY:KASRA	Borehole
3319DC00036	RY07	RIETVALLY:KASRA	Borehole

3319DC00037	RY08	RIETVALLY:WERK-EN-RUS	Borehole
3319DC00038	RY09	RIETVALLY:WERK-EN-RUS	Borehole
3319DC00039	RY10	RIETVALLY	Borehole
3319DC00040	RY11	RIETVALLY:WERK-EN-RUS	Borehole
3319DC00041	RY12	RIETVALLY:WERK-EN-RUS	Borehole
3319DC00042	RY13	RIETVALLY:WERK-EN-RUS	Borehole
3319DC00116	RY14	RIETVALLEY, Riviergat	Borehole
3319DD00123	S	Small holding of Mr. Lamprecht	Borehole
3319DD00132	SAN01	SANDRIF CANAL	Canal or trench
3319DD00133	SAND	SANDRIVER, at main road	River or stream
3319CD00058	SG01	SETTINS BERG - STETTYN	Borehole
3319DA00102	SMIT	BOVEN KLOPPERBOSCH	Borehole
3320CC00103	ST65	ZANDVLIET, drain from centre-pivot grain land	Tunnel, shaft or drain
3320CC00104	ST66	ZANDVLIET, drain from vines and peaches	Tunnel, shaft or drain
3319DC00109	T	DE FONTEIN, northern part below dam.	Borehole
3319DD00054	TY01	TAKKAPS VALLEY	Borehole
3319DD00055	TY02	TAKKAPS VALLEI	Borehole
3319DD00056	TY03	TAKKAPS VALLEI - TAKKAP	Borehole
3319DD00057	TY04	TAKKAPS VALLEI - TAKKAP	Borehole
3319DD00134	TY_SIG	TAKKAPS VALLEY, Seepage water in creek	Seepage pond
3319DC00108	U	DE FONTEIN, 300 m N of homestead	Borehole
3319DD00027	VD01	VROLYKHEID - THORNVILLA	Borehole
3319DD00058	VD02	VROLYKHEID - THORNVILLA	Borehole
3319DD00059	VD03	VROLYKHEID - THORNVILLA	Borehole
3319DD00060	VD04	VROLYKHEID - MC GREGOR WYNKELDER	Borehole
3319DD00061	VD05	VROLYKHEID - VOORUITSIG	Borehole
3319DD00062	VD06	VROLYKHEID - KONINGSRIVIER	Borehole
3319DD00063	VD07	VROLYKHEID - KONINGSRIVIER	Borehole
3319DD00064	VD08	VROLYKHEID - KONINGSRIVIER	Borehole
3319DD00065	VD09	VROLYKHEID - KONINGSRIVIER	Borehole
3319DD00130	VOOGDS_GROOT	GROOT KLAAS VOOGDS RIVER, at Riversdale road	River or stream
3319DD00129	VOOGDS_KLEIN	KLEIN KLAAS VOOGDS RIVER, at Riversdale road	River or stream
3319DA00008	VR01	VINKRIVIER - AMANDALIA	Borehole
3319DA00009	WF01	WAAIKLOOF - GLEN OAK	Borehole
3319DC00111	X	RIETVALLY	Borehole
3319DC00110	Y	POESFAS VALLY, just above dam	Borehole
3319DD00111	Z	DE HEX RIVIER, ca 50 m NW road junction	Dug well
3319DD00066	ZN01	ZAND BERG FONTEIN - SANDBERG	Borehole
3319DD00067	ZN02	ZAND BERG FONTEIN - SANDBERG	Borehole
3319DD00068	ZN03	ZAND BERG FONTEIN, Sandberg, NW of road	Borehole
3319CD00059	ZR01	ZANDRIVIER - KEERWEDER	Borehole

Appendix 2

Exploration boreholes: Borehole logs

Site-ID : 33190002572

Nr on Map : 633572A

* HydroGraph * Borehole log - Breede River Project

Coordinates : -88912.18 (E-W) 3746025.40 (N-S) 153.16 (Ground elevation)

Date Plotted: Oct 17 1991

Progressive yield (l/s)

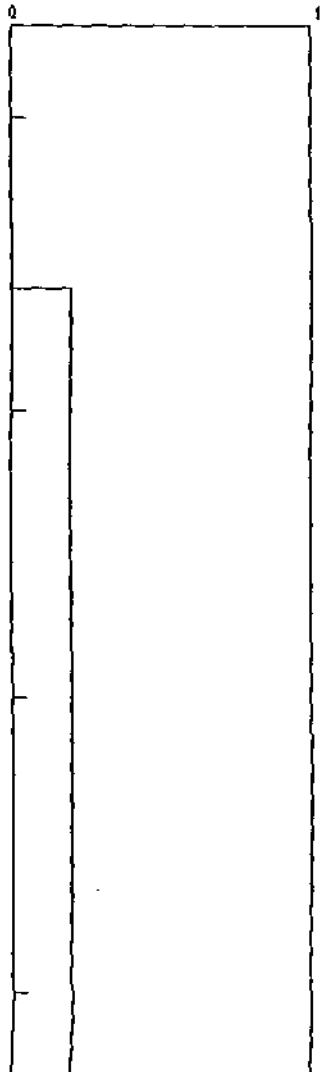

elec. Cond (uS/m)

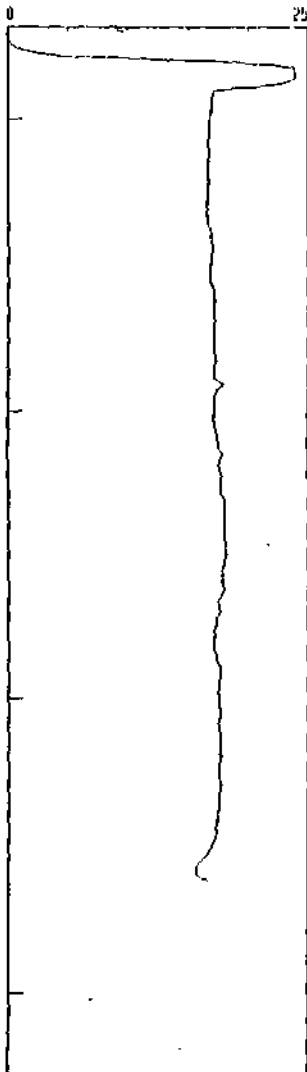

Constr. (mm)



m aasi

150.
140.
130.
120.
110.

Geology

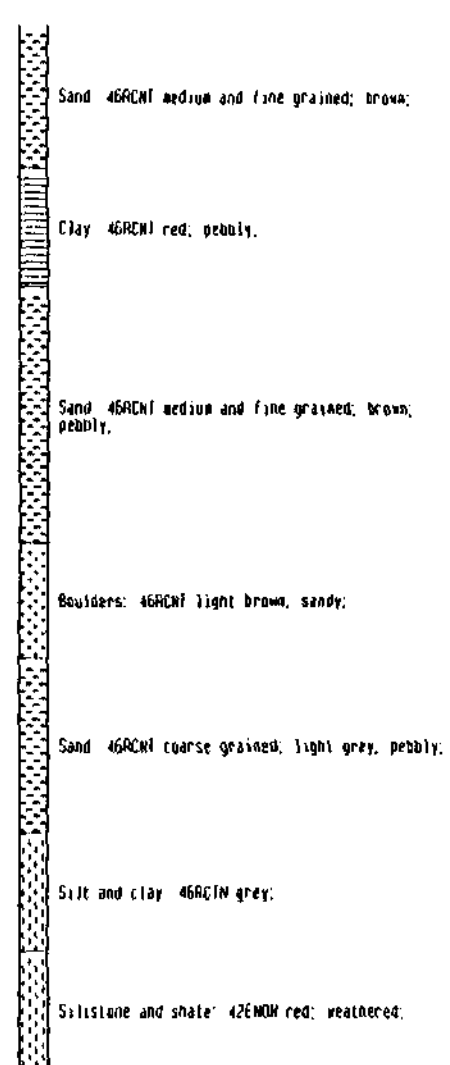

Site-ID : 33190000005

Nr on Map : G33573

* HydroGraph * Borehole log *Bredde River Project*

Coordinates : -83898.49(E-W) 3746071.24(N-S) 148.38(Ground elevation)

Date Plotted: Oct 17 1991

Progressive field (l/s)

Elec. Cond (uS/m)

Constr (mm)

m amsl

Geology

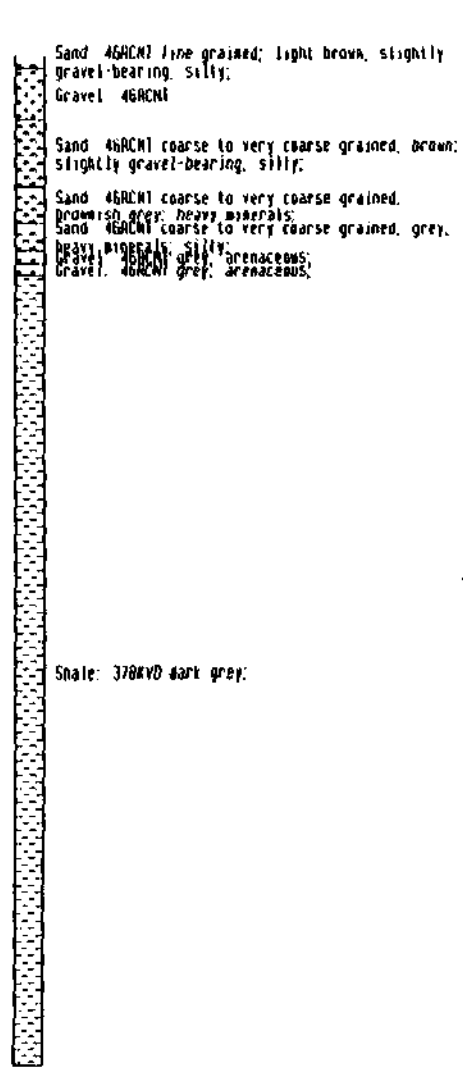
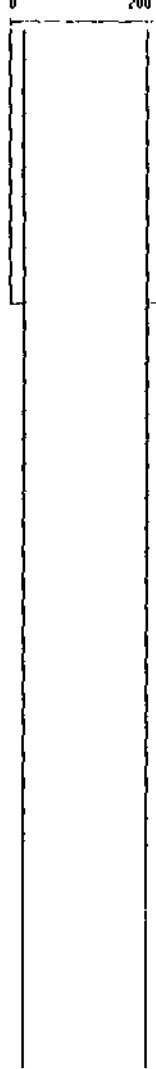
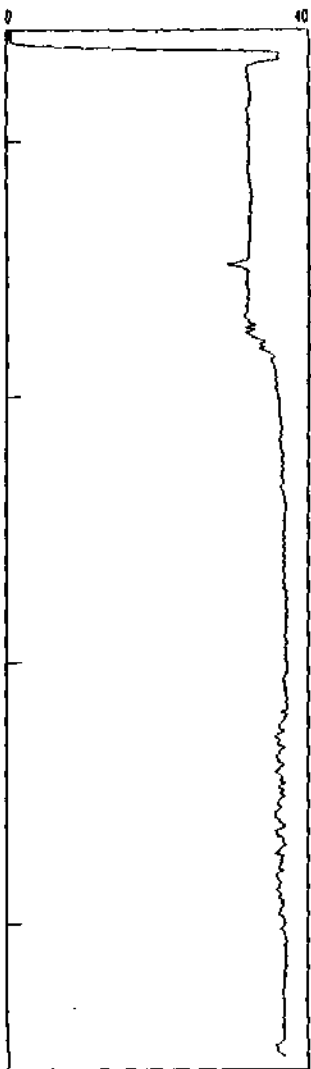
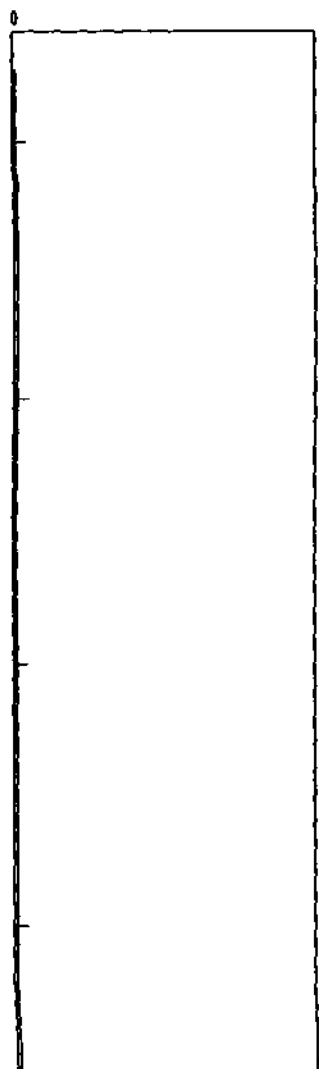

7

Site-ID : 3319000007

Nr on Map : G33575

HydroGraph X Borehole log : Greede River Project

Coordinates : -88392.41 (E-W) 3746632.27 (N-S) 141.73 (Ground elevation)

Date Plotted: Oct 21 1991

Progressive Yield (l/s)

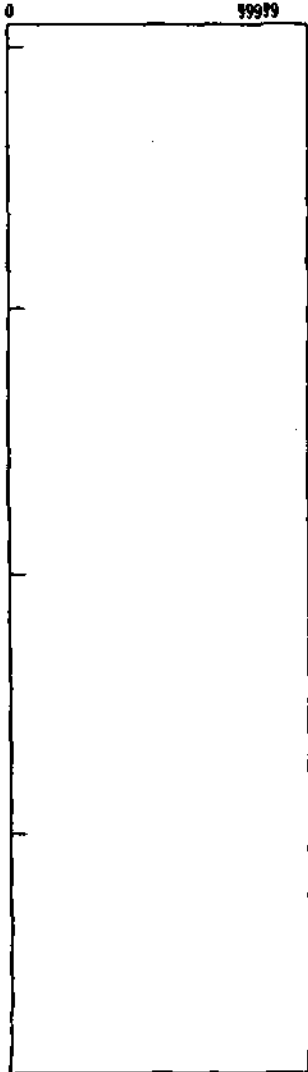

Elec. Cond. (µS/m)

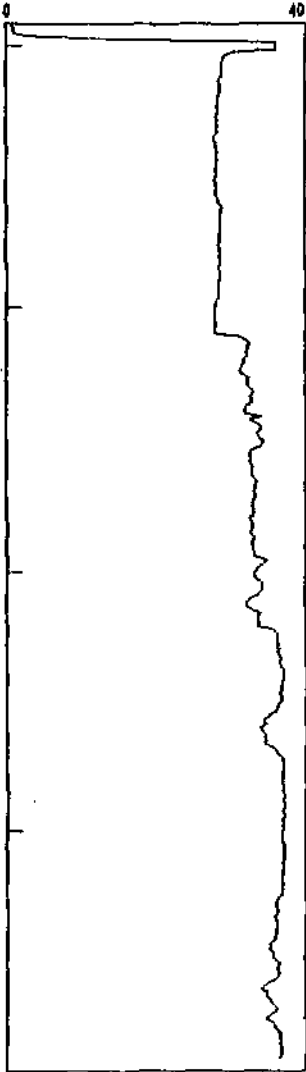

Constr. (mm)

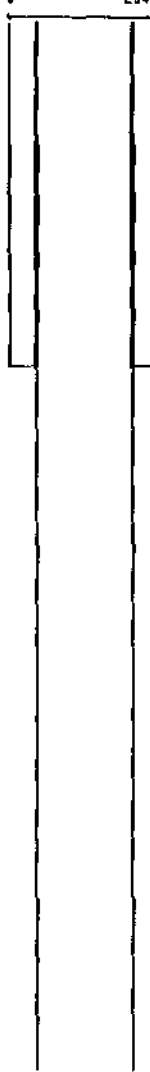

n (aws)



Geology

Sand: 46RCN1 very fine grained, yellowish brown,
 silty, medium to coarse grained, yellowish
 brown, silty, medium to coarse grained, yellowish
 brown, silty, medium to coarse grained,
 gravel, 46RCN1 very fine to coarse grained,
 silty, medium to coarse grained, yellowish
 brown, silty, medium to coarse grained, white,
 silty, medium to coarse grained, coarse grained,
 silty, medium to coarse grained, white, heavy
 minerals, gravel-bearing.

Conglomerate: 46RCN1

Site-ID : 33190D02576

Nr on Map : G33576A

* HydroGraph * Borehole log Breede River Project

Coordinates : -88496.44 (E-W) 3746655.36 (N-S) 119.90 (Ground elevation)

Date Plotted: Oct 17 1991

Elec. Cond. [mS/m]

22

32

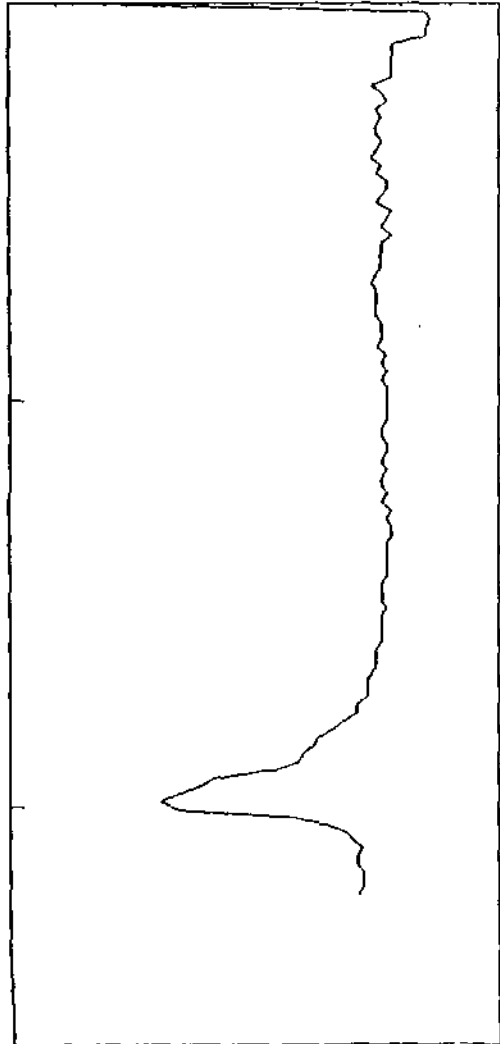

Constr. [mm]

0

254



m asst

140.

130.

120.

114.

Geology



Sand 46RCH1 medium grained; brownish grey.

Sand and silt 46RCH1 fine grained, brownish pink;

Clay and sand 46RCH1 fine grained, grey;

Sand 46RCH1 coarse and medium grained, greyish white;

Gravel 46RCH1 medium to coarse grained; grey;

Clay 42ENDM red; weathered;

6

Site-ID : 33190000009

Utr on Map : 633577

* HydroGraph * Borehole log Breede River Project

Coordinates : -88185.69(E-W) 3746964.14(N-S) 147.75(Ground elevation)

Date Plotted: Oct 17 1991

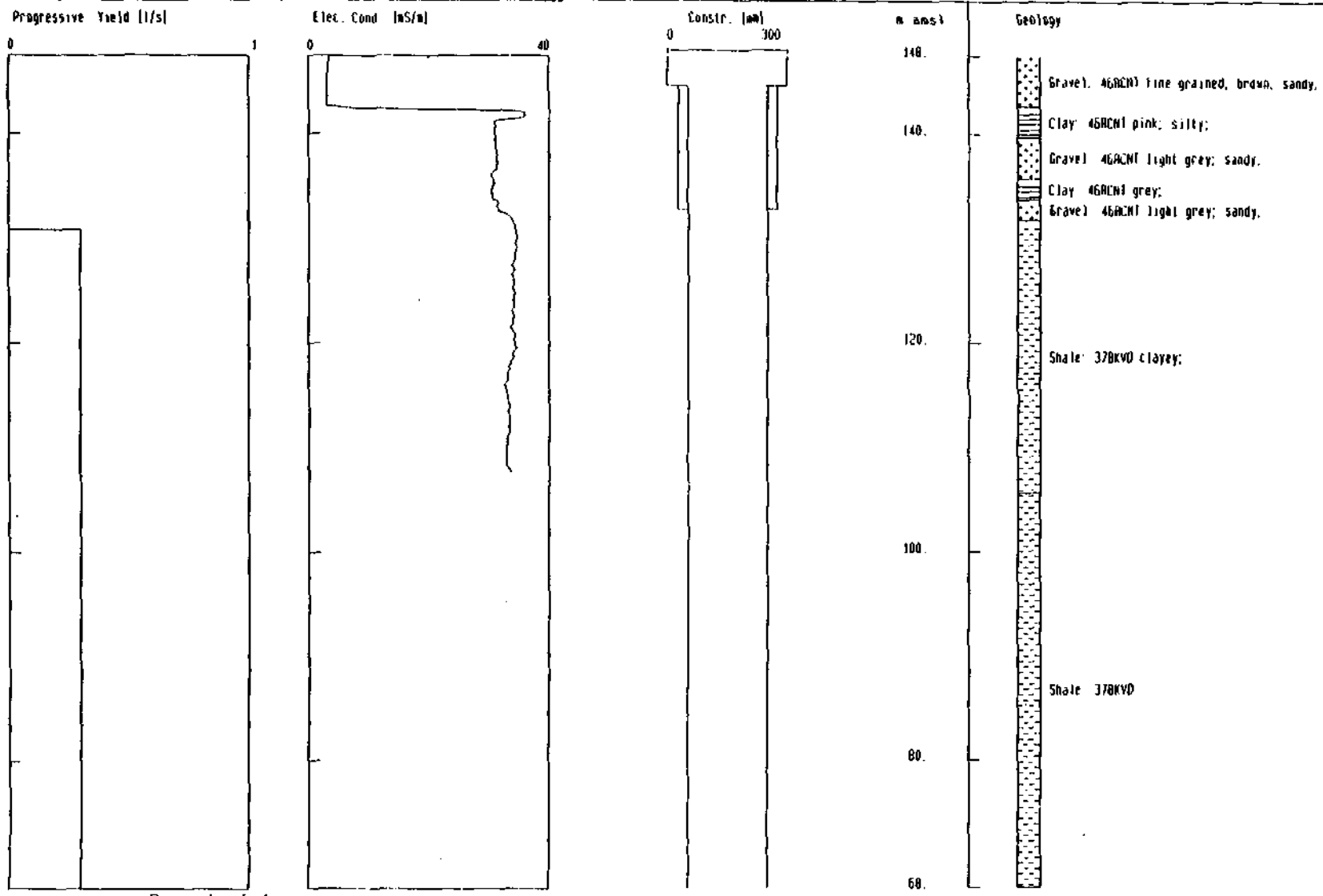

10

Site-10 : 33190000010

Nr on Map : G33578

* HydroGraph * Borehole log Breede River Project

Coordinates : -86462.38 (E-W) 3747136.92 (N-S) 164.89 (ground elevation)

Date Plotted: Oct 17 1991

Elec. Cond. (mS/m)

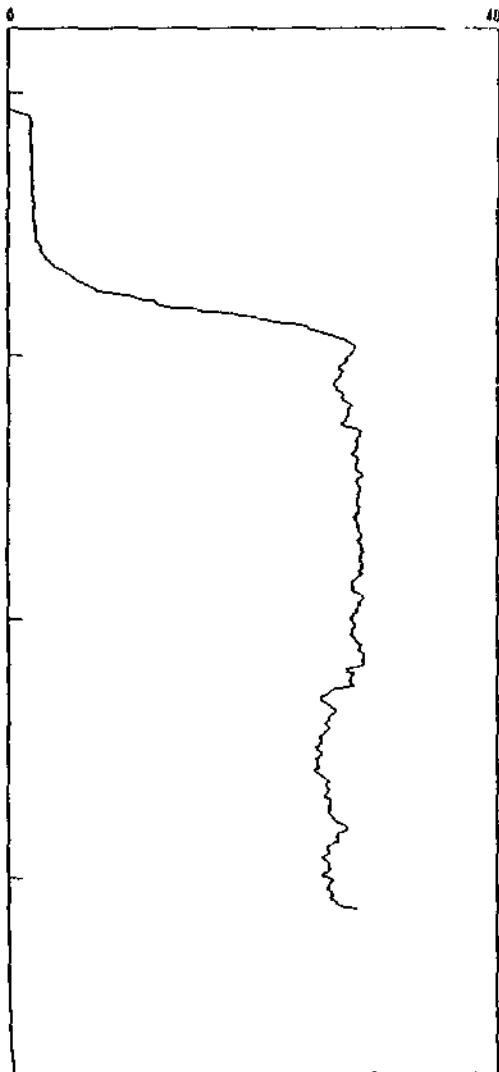

Constr. (mm)

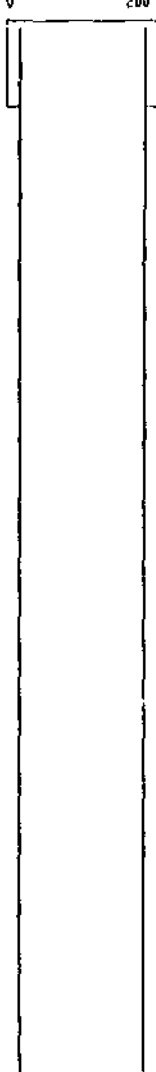

m amsl



Geology

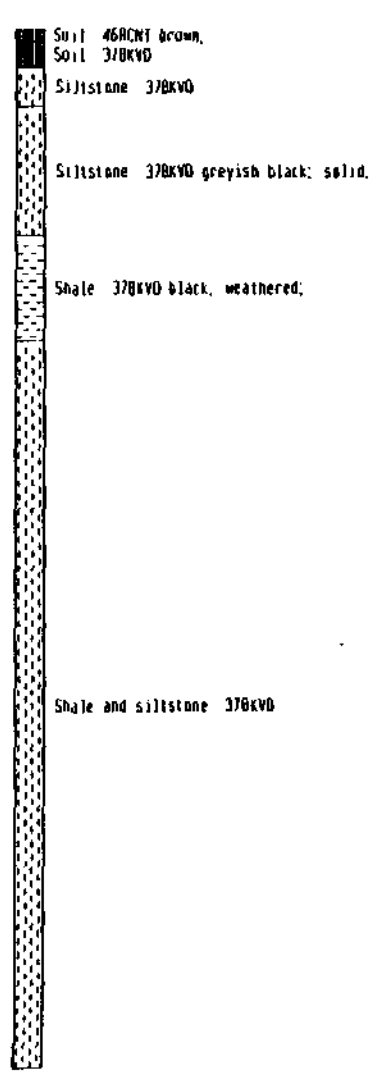

11

Site-ID : 3319DD00016

No on Map : 633584

* HydroGraph * Borehole log Breede River Project

Coordinates : -83363.75 (E-W) 3748927.56 (N-S) 149.79 (Ground elevation)

Date Plotted: Oct 18 1991

Progressive Yield (l/s)

Elec. Cond. (µS/m)

Constr. (mm)

m asl

Geology

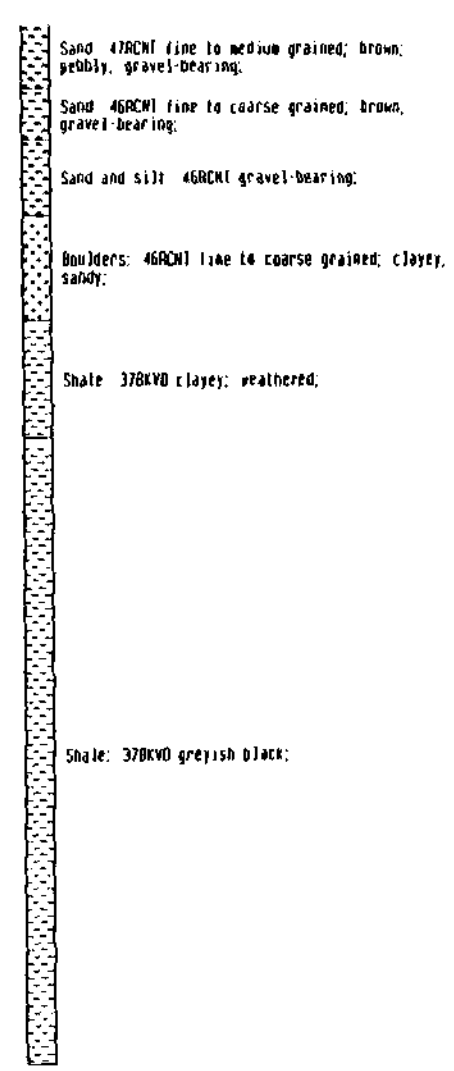
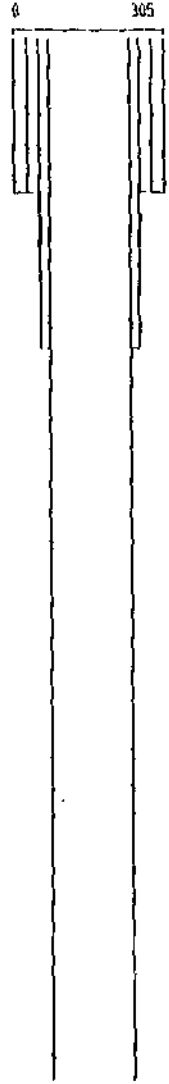
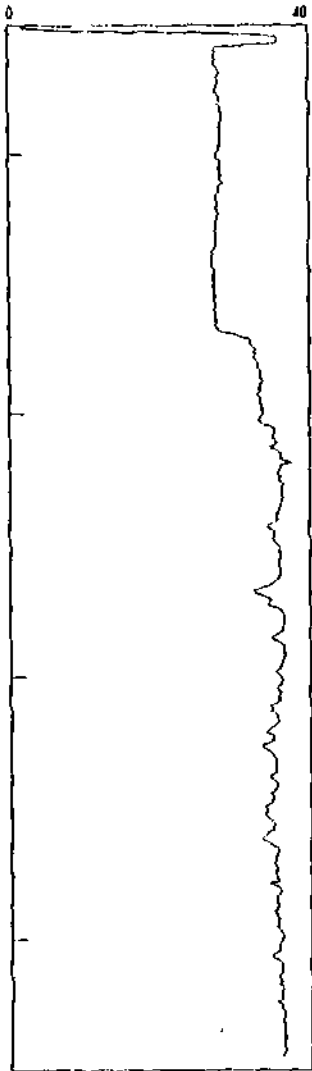
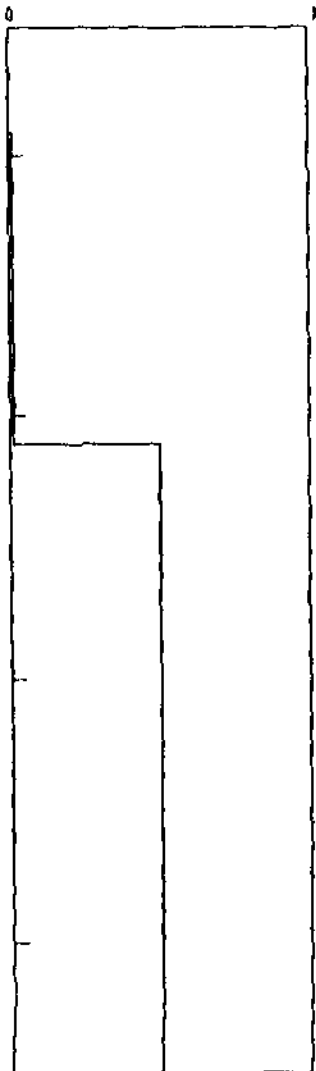

Site-ID : 33190004584

No on Map : G33584C

* HydroGraph * Borehole log Breede River Project

Coordinates : -03606 20 (E-W) 3745671.61 (N-S) 148.66 (Ground elevation)

Date Plotted: Oct 18 1993

Progressive Yield (l/s)

Elec. Cond. (uS/m)

Constr. (mm)

m. ans.)

Geology

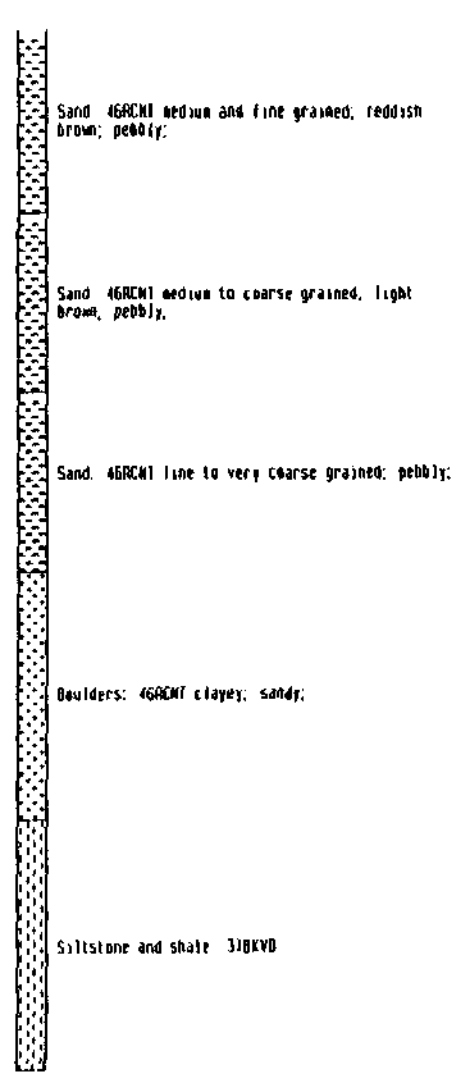
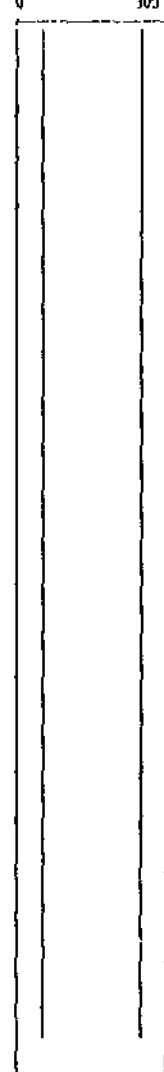
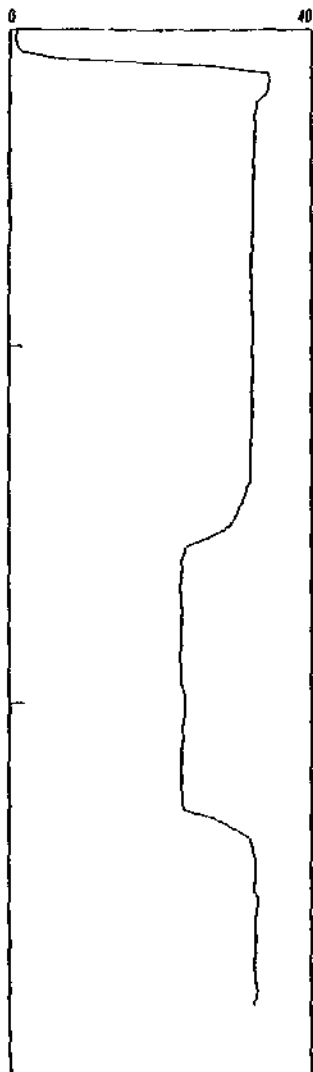
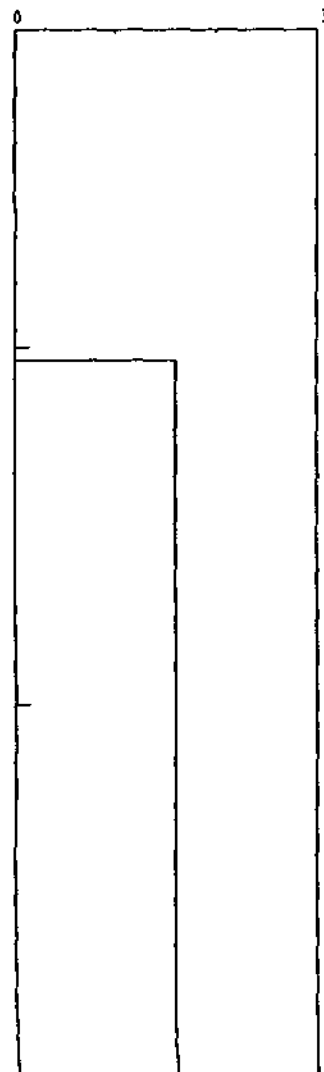

13

Site-ID : 33190000021

No on Map : C33589

* HydroGraph * Borehole log - Breede River Project

Coordinates : -87171.16 (E-W) 3747975.36 (N-S) 117.72 (Ground elevation)

Date Plotted: Oct 18 1991

Elec. Cond. (uS/m)

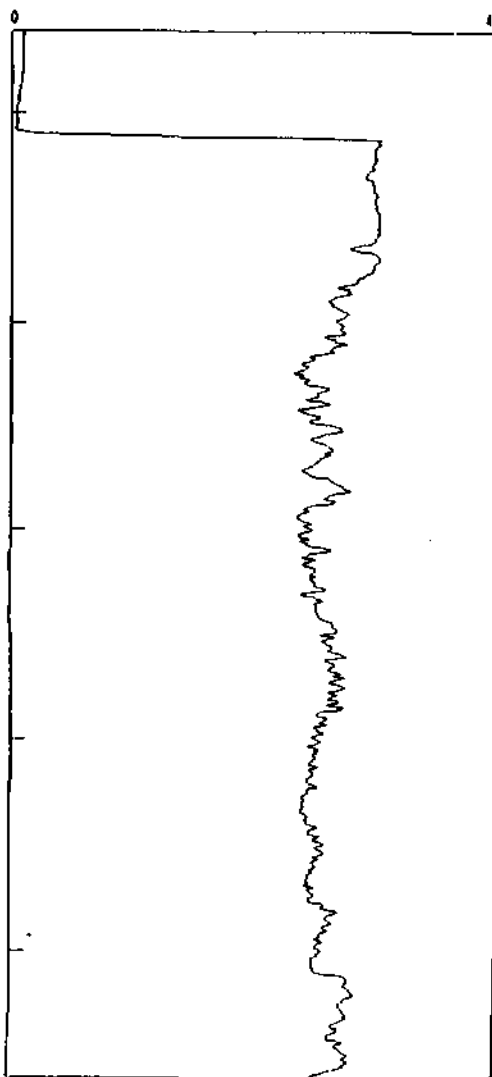

Constr. (mm)

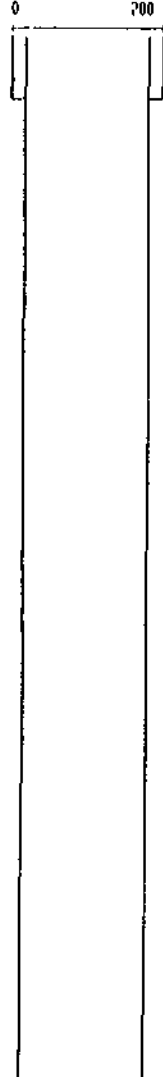

m amsl

168.
160.
140.
120.
100.
80.
68.

Geology

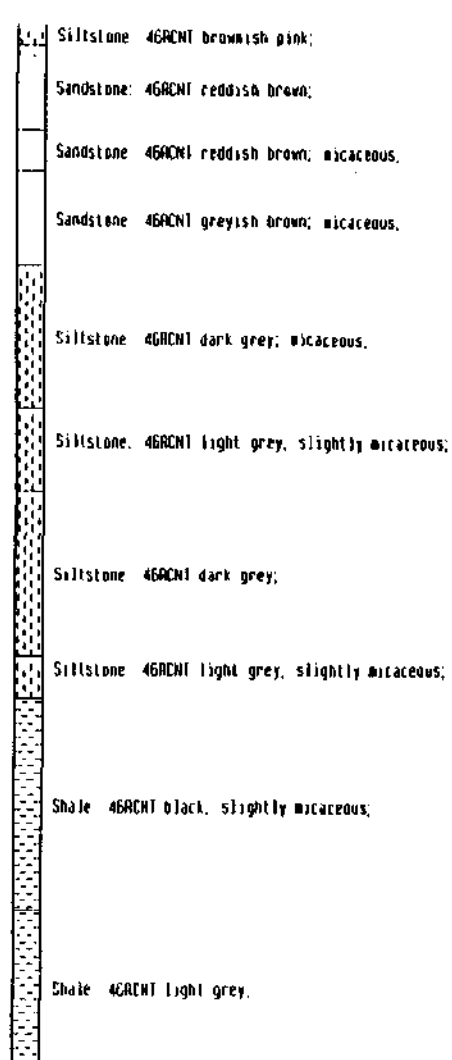

Site-ID : 33190000022

Nr on Map : G33590

* HydroGraph * Borehole Log : Breede River Project

Coordinates : -83220.82 (E-W) 3746922.78 (N-S) 149.32 (Ground elevation)

Date Plotted: Oct 18 1991

Progressive Yield (l/s)

Elec. Cond. (µS/m)

Conctr. (mm)

n anal

Geology

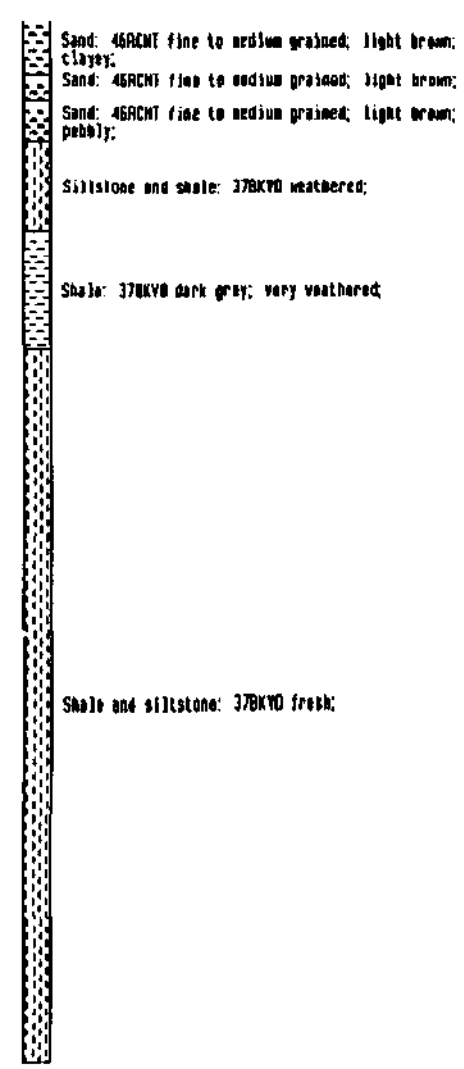
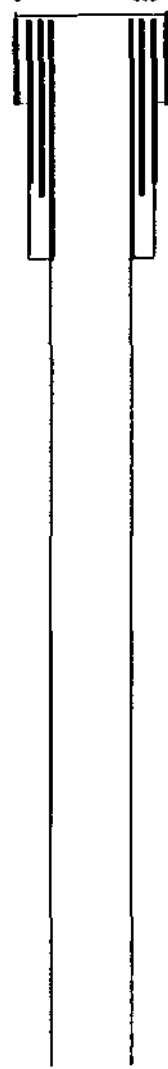
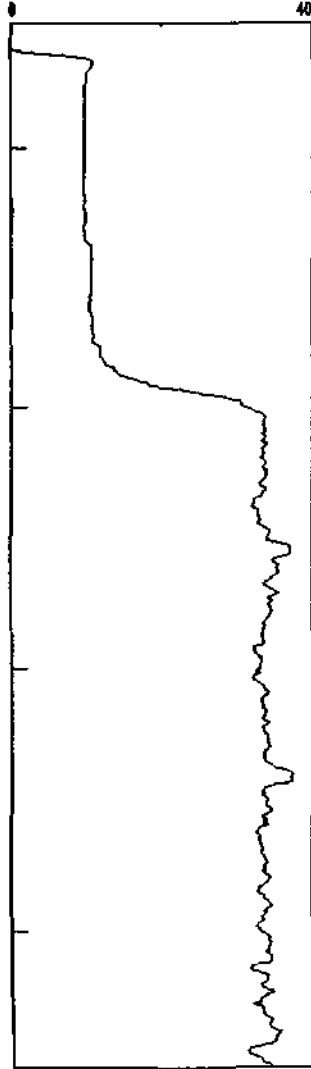
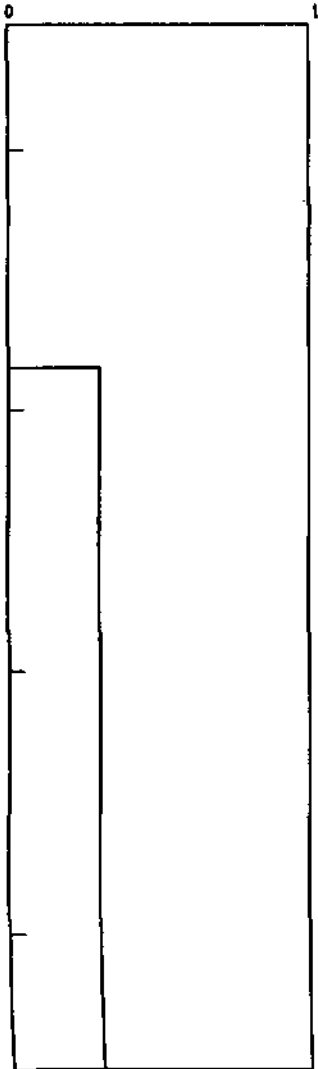

15

Site-ID : 3319000023

Nr on Map : G33591

* HydroGraph * Borehole log : Breede River Project

Coordinates : -85358.35(E-W) 3746695.44(N-S) 145.80(Ground elevation)

Date Plotted: Oct 18 1991

Progressive Yield [l/s]

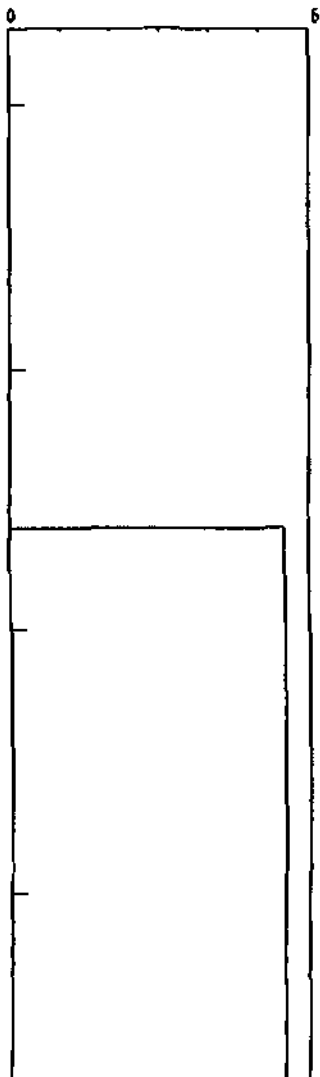

Elec. Cond. [µS/m]

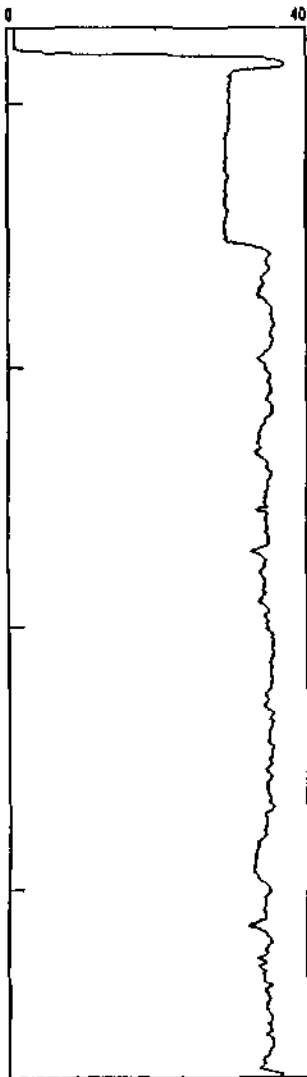

Constr. [cm]

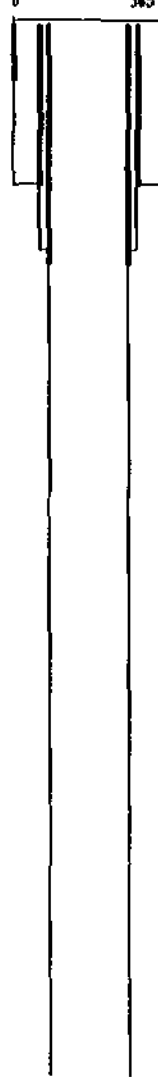

m asnl



Geology

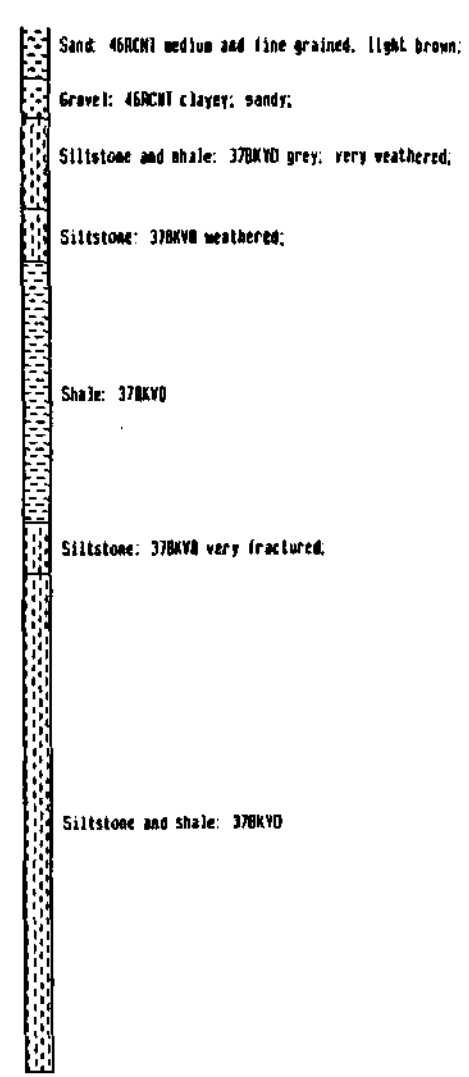

Site-ID : 3319DD00024

Nr on Map : G33592

* HydroGraph * Borehole log - Breede River Project

Coordinates : -83939.84(E-W) 3747052.22(N-S) 147.32(Ground elevation)

Date Plotted: Oct 21 1991

Progressive Yield (l/s)

Elec. Cond. (mS/m)

Constr. (mm)

m asl

Geology

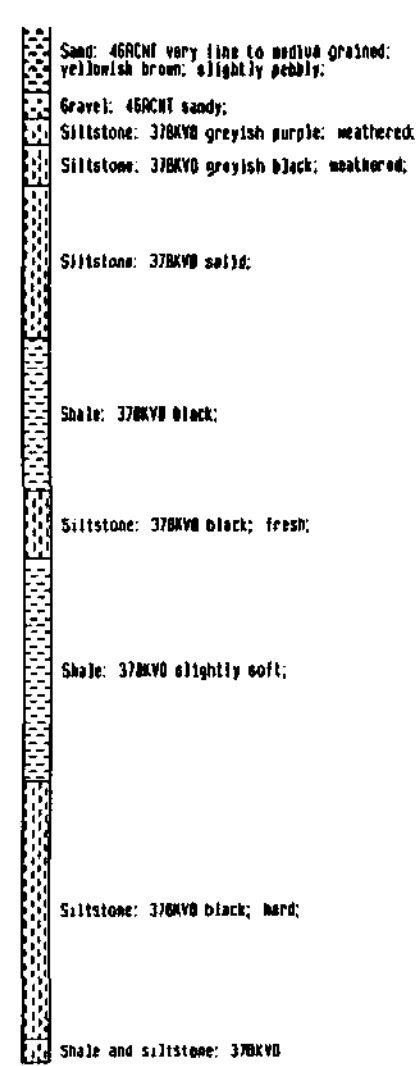
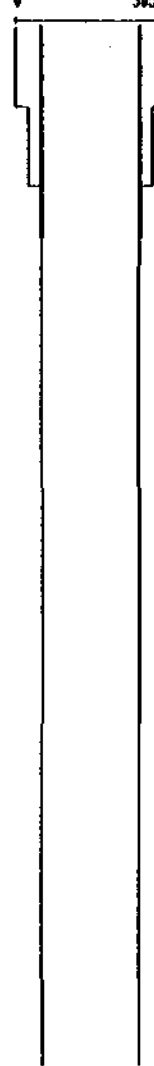
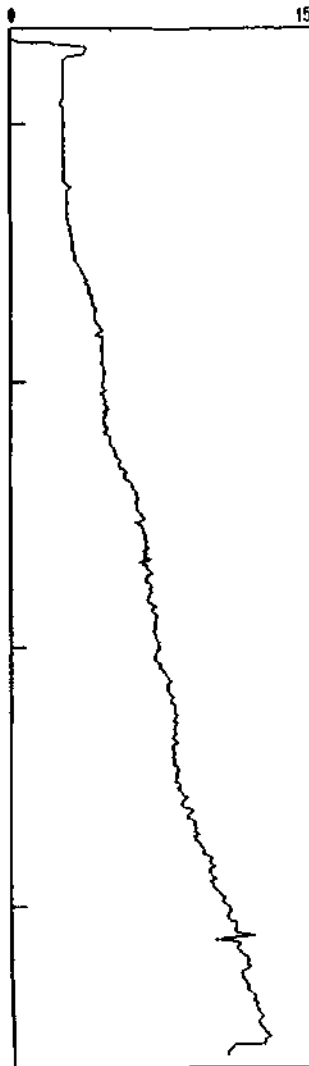
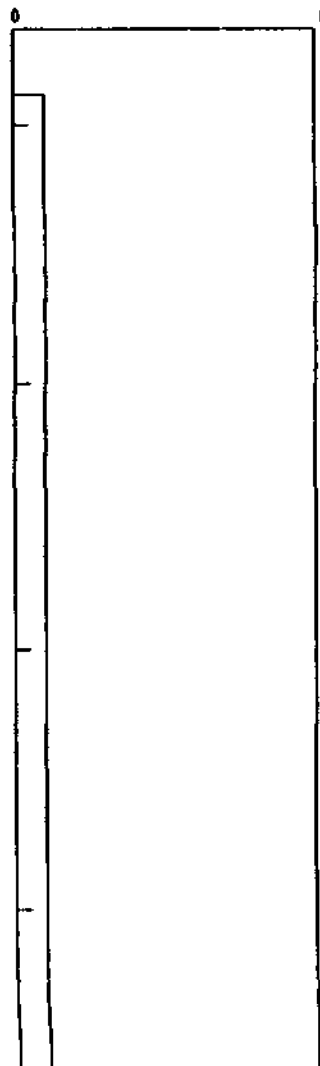

Site-ID : 33190001596

Nr on Map : G33596

* HydroGraph * Borehole log - Breede River Project

Coordinates : -87179.72 (E-W) 3746760.75 (N-S) 143.41 (Ground elevation)

Date Plotted: Oct 18 1991

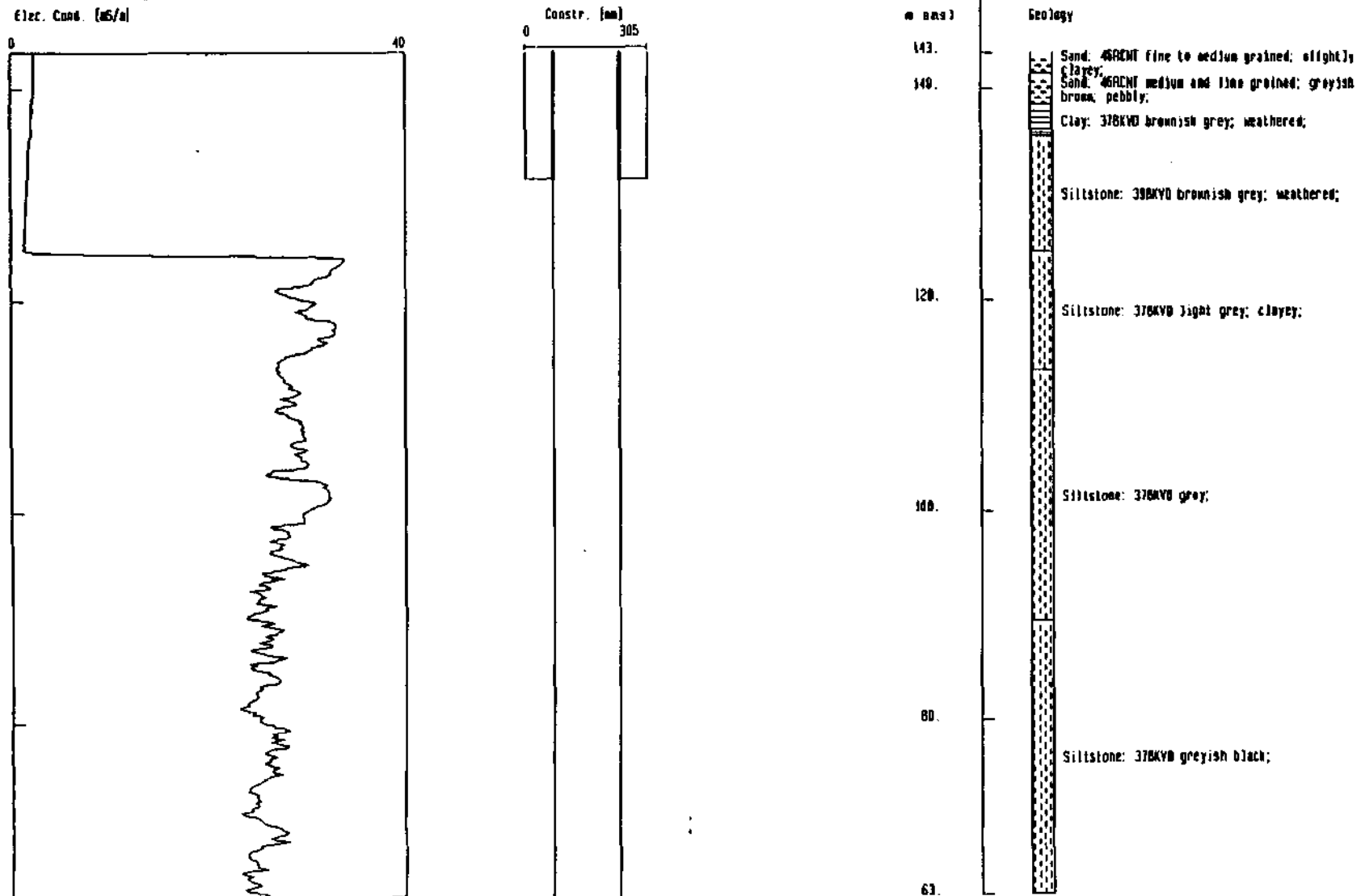

18

Site-ID : 33190002596

Nr on Map : G33596A

* HydroGraph * Borehole log : Breede River Project

Coordinates : -87196.15(E-W) 3746761.73(N-S) 143.58(Ground elevation)

Date Plotted: Oct 18 1991

Progressive Yield (l/s)

Elec. Cond. (µS/m)

Constr. (mm)

n ows 1

Geology

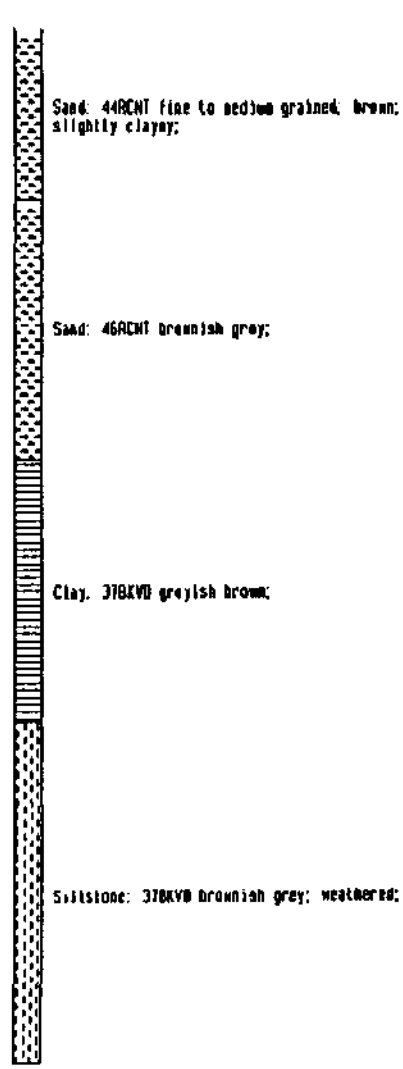
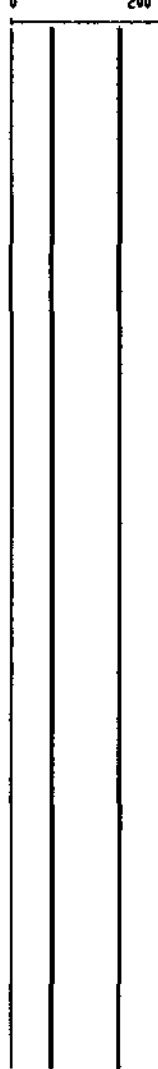
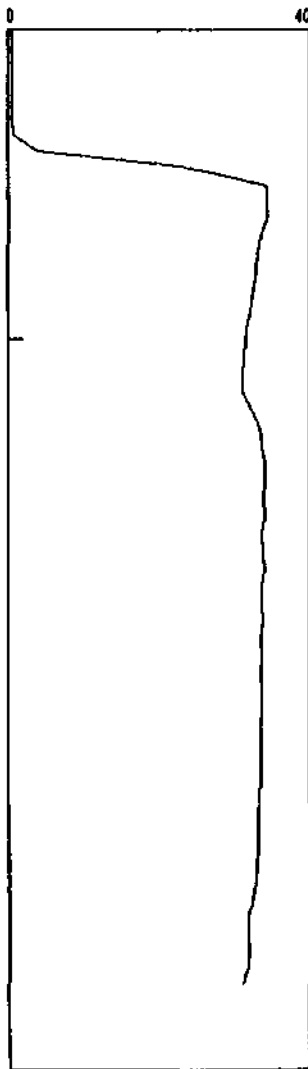
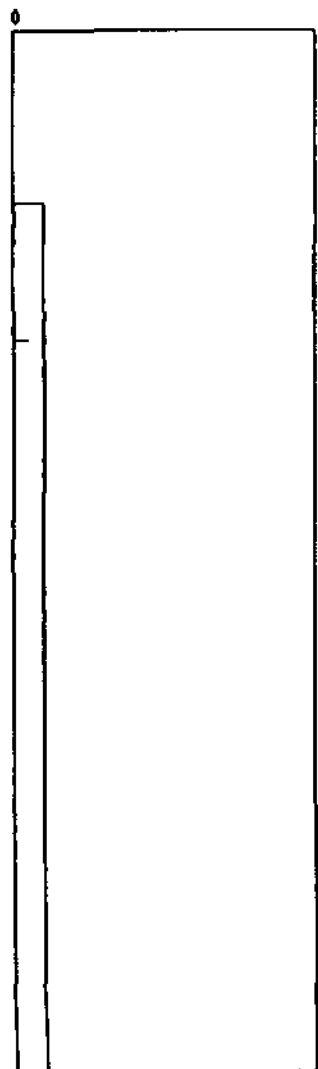

19

Site-ID : 33190002597

NO on Map : G33597X

* HydroGraph * Borehole log * Breede River Project

Coordinates : -87712.34 (E-W) 3747636.28 (N-S) 153.49 (Ground elevation)

Date Plotted: Oct 18 1991

Elec. Cond. (uS/m)

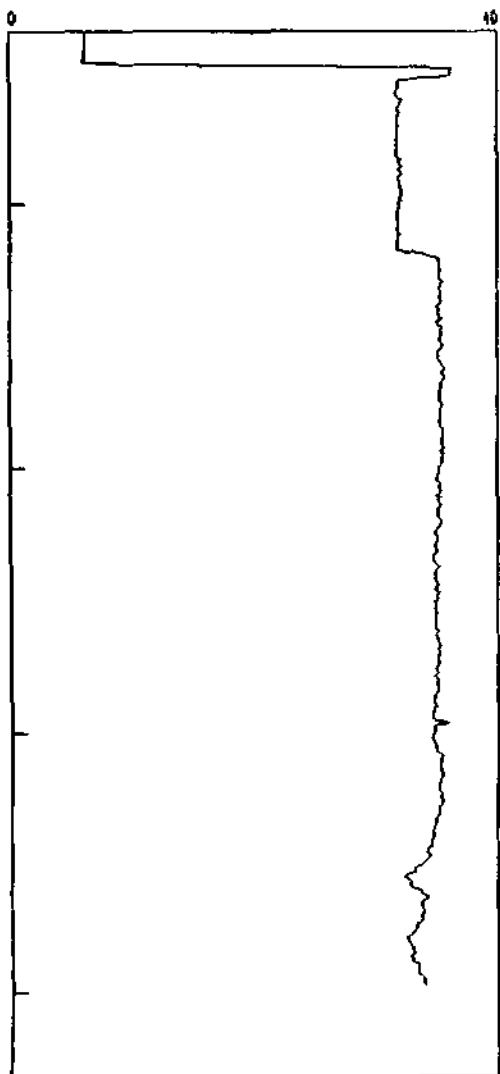

Constr. (mm)

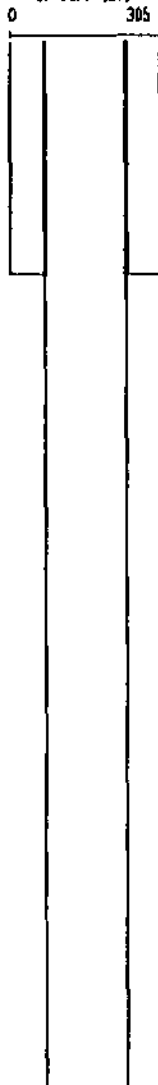

m ans1



Geology

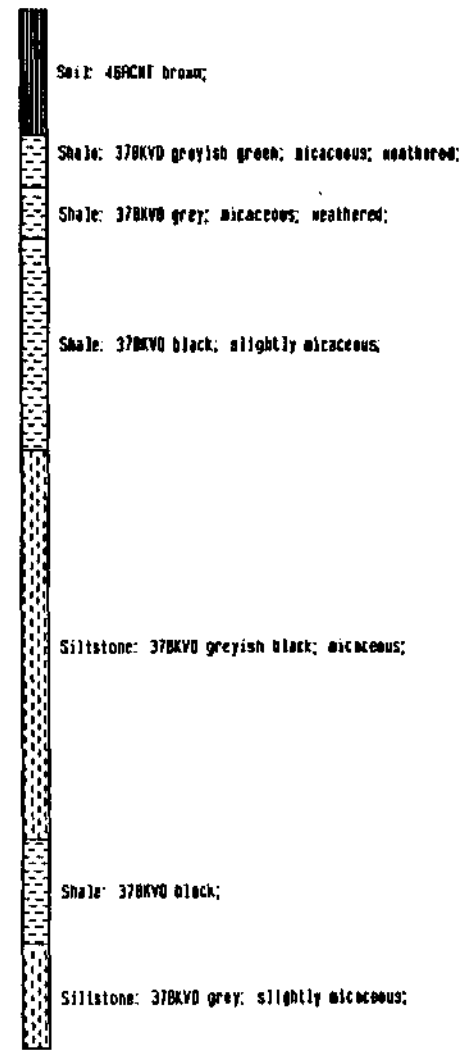

Site-ID : 3319D001598

Nr on Map : G33598

* HydroGraph * Borehole log : Breede River Project

Coordinates : -84851.83 (E-W) 3746317.97 (N-S) 146.74 (Ground elevation)

Date Plotted: Oct 18 1991

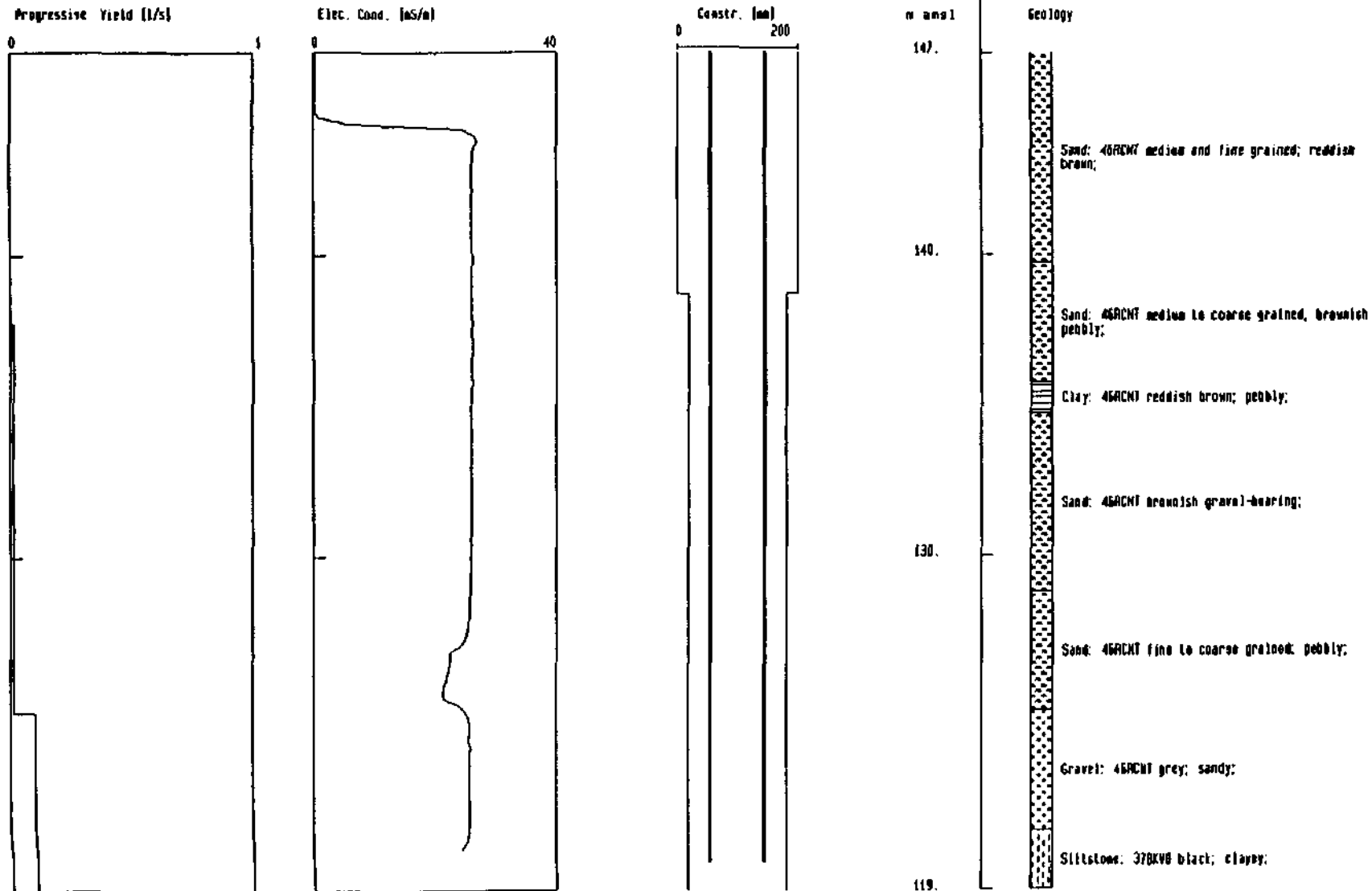

Site-ID : 33190001599

No on Map : G33599

* HydroGraph * Borehole log : Breede River Project

Coordinates : -86039.55(E-W) 3746342.22(N-S) 145.68(Ground elevation)

Date Plotted: Oct 18 1991

Progressive Yield (l/s)

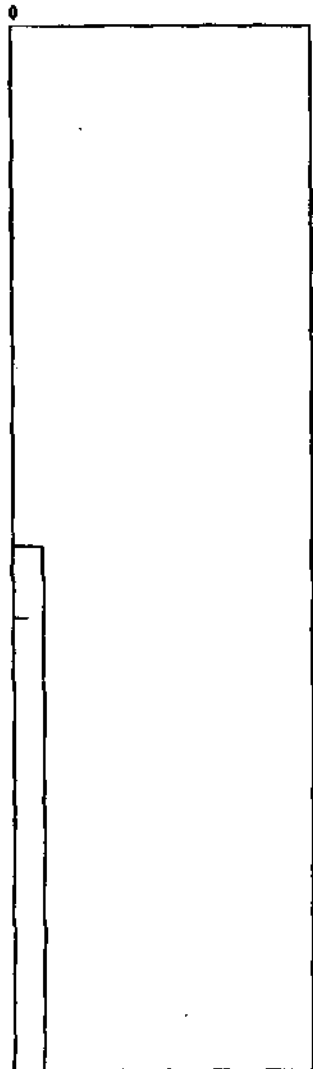

Elec. Cond. (µS/m)

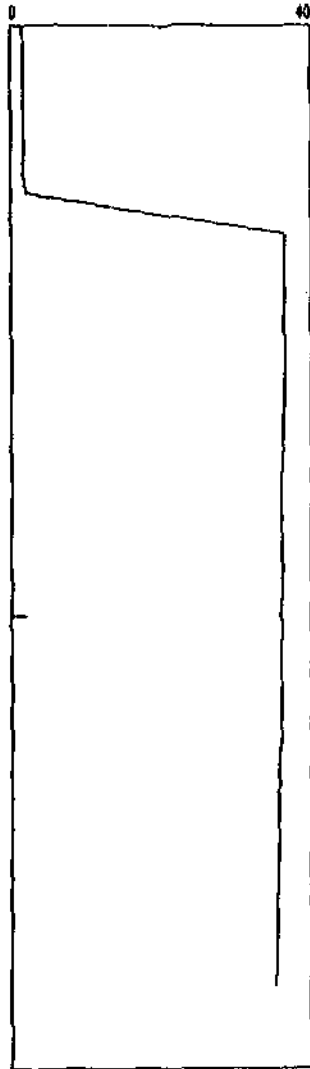

Constr. (mm)



m asl



Seology



Sand: 46RCNT medium and fine grained; brown, pebbly;

Gravel, sand and clay: 46RCNT very fine to medium grained;

Siltstone: 378KVD fractured; weathered;

Siltstone: 378KVD black; clayey;

Site-ID : 33190001600

Nr on Map : G33600

* HydroGraph * Borehole log : Breede River Project

Coordinates : -73741.92 (E-W) 3742908.82 (N-S) 182.77 (Ground elevation)

Date Plotted: Oct 21 1991

Progressive Yield (l/s)

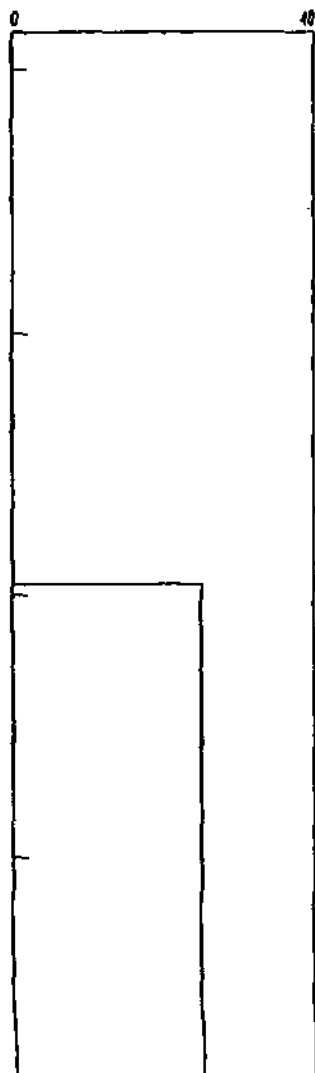

Elec. Cond (uS/m)

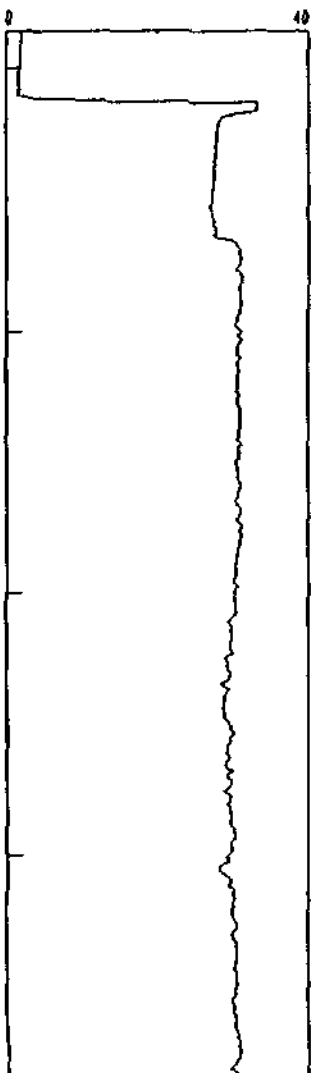

Constr. (m)

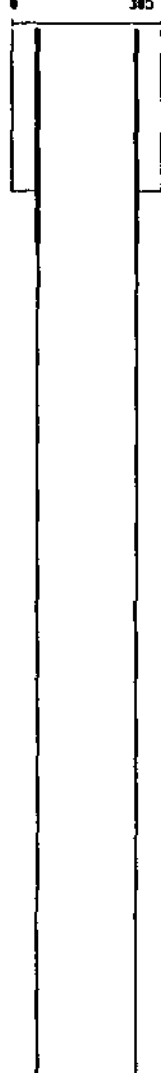

m amsl



Geology

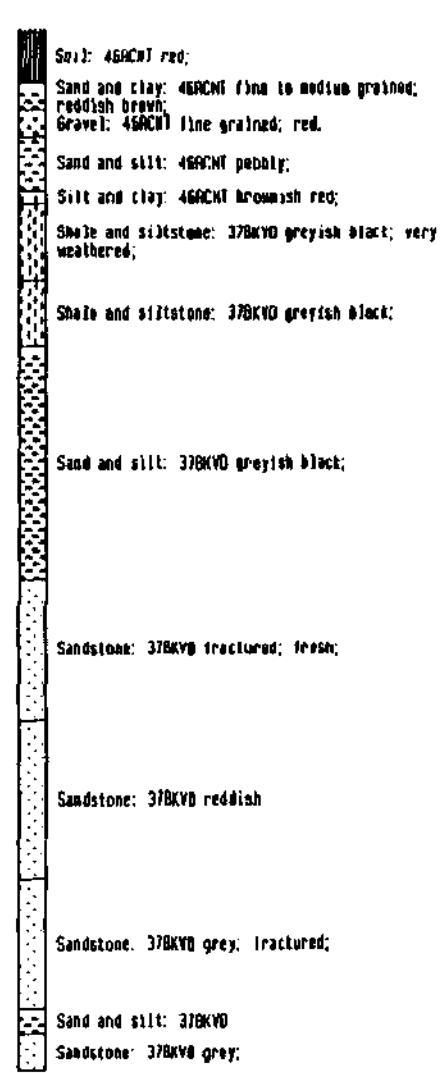

23

Site-ID : 33190004600

Nr on Map : G33600E

* HydroGraph * Borehole log - Breede River Project

Coordinates : -73740.53 (E-W) 3742037.96 (N-S) 182.80 (Ground elevation)

Date Plotted: Oct 21 1991

Progressive Yield [l/s]

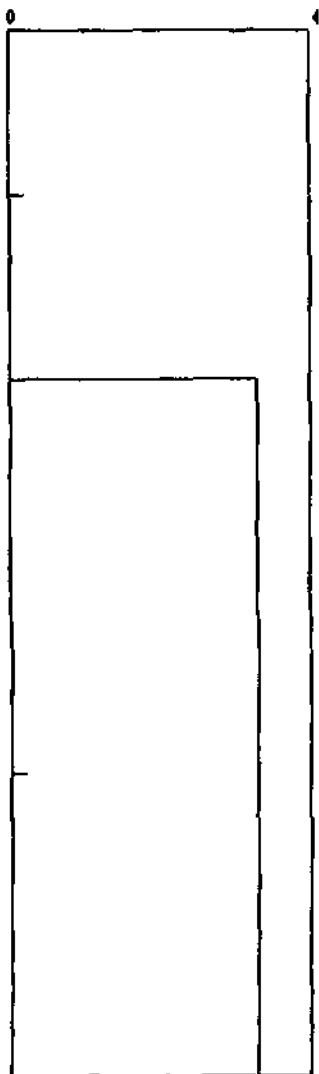

Elec. Cond. [uS/m]

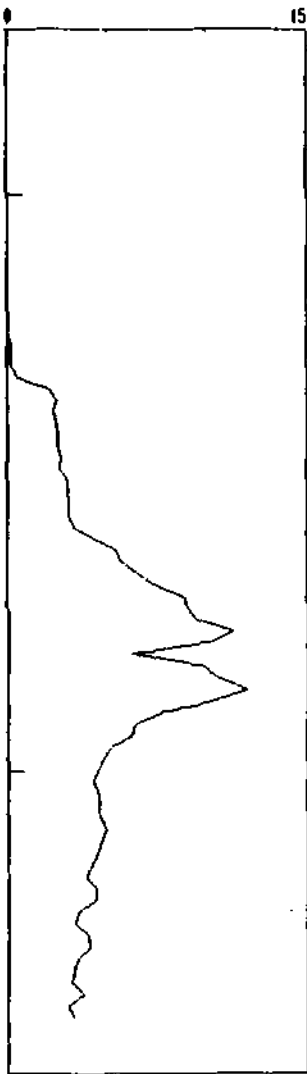

Constr. [mm]



m aspl



Geology

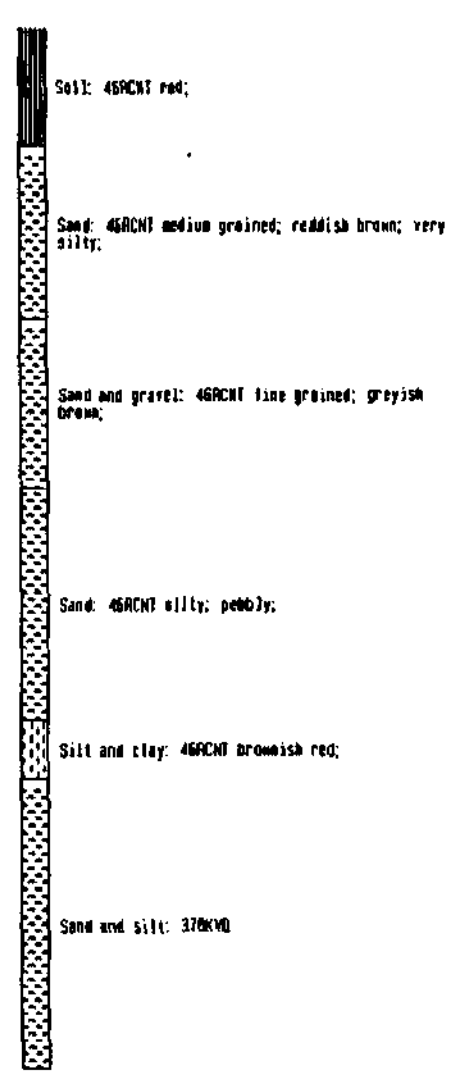

Site-ID : 33190001601

Nr on Map : G33601

* HydroGraph * Borehole log - Breede River Project

Coordinates : -72903.74 (E-W) 3743175.29 (N-S) 180.42 (Ground elevation)

Date Plotted: Oct 21 1991

Progressive Yield (l/s)

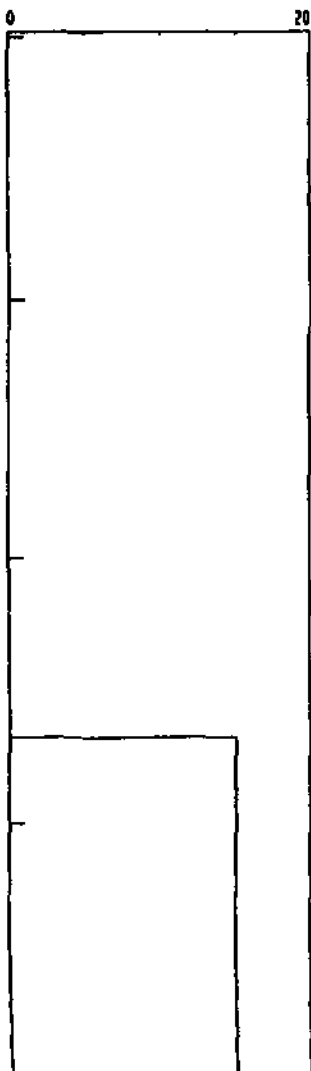

Elec. Cond. (uS/m)

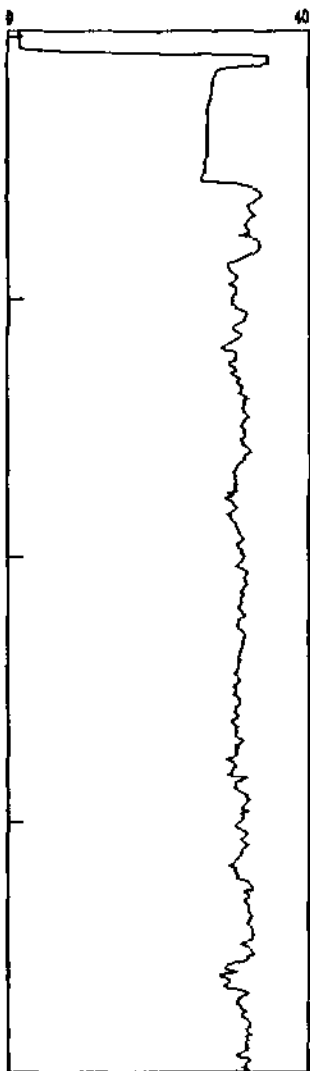

Constr. (mm)

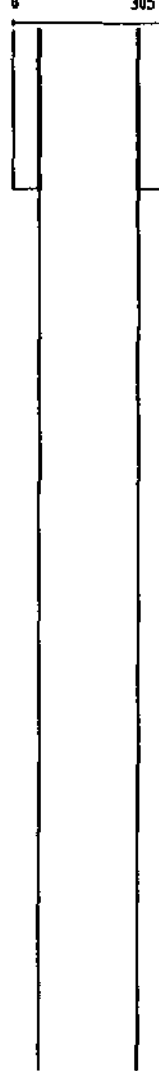

n and s1

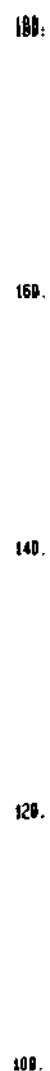

Geology

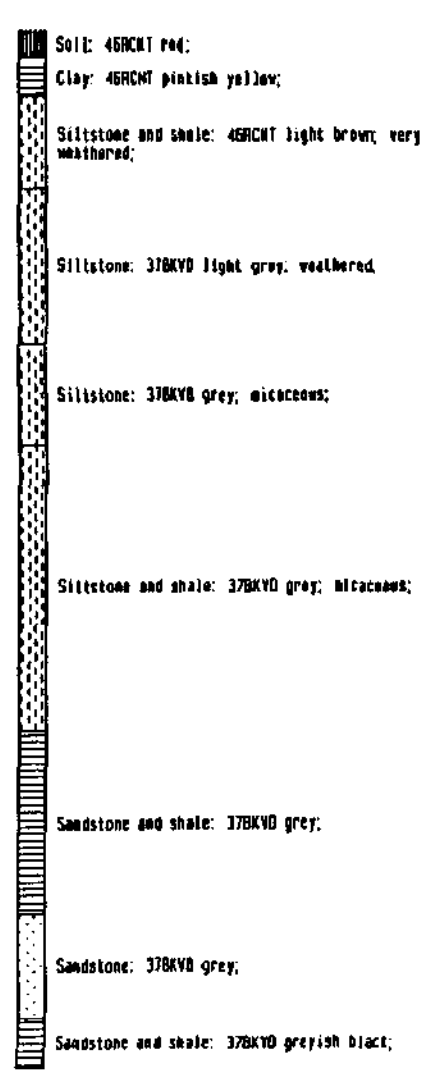

Site-ID : 33190001610

Nr on Map : G33610

* HydroGraph * Borehole log * Breede River Project

Coordinates : -72785.66 (E-W) 3741572.72 (N-S) 190.09 (Ground elevation)

Date Plotted: Oct 21 1991

Progressive Yield (l/s)

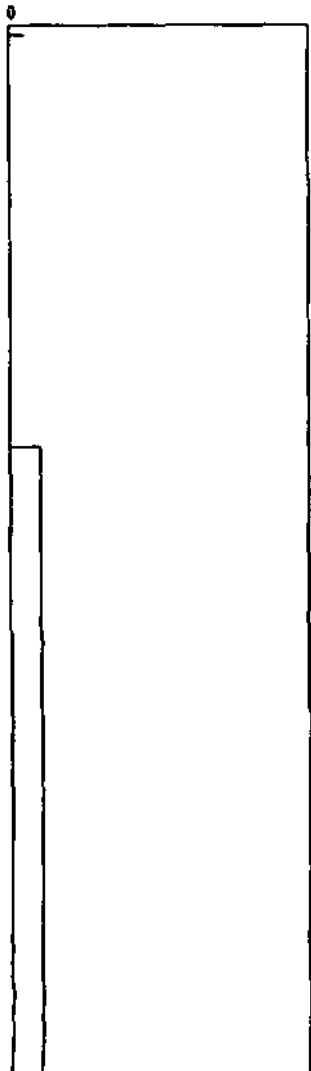

Elec. Cond. (mS/m)

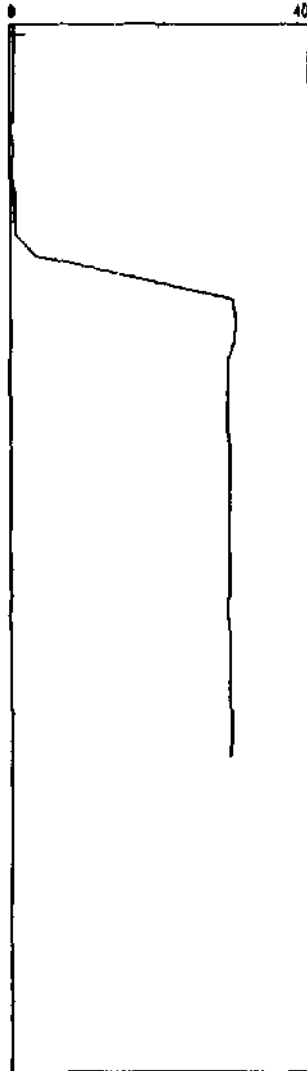

Constr. (m)

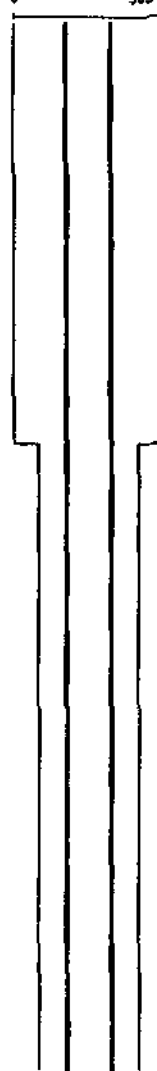

m ans1

198

189

Geology

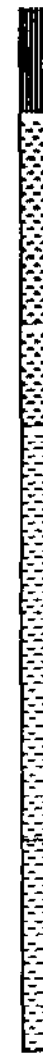

Soil: 46RCNT brown; sandy;

Sand and gravel: 46RCNT medium grained; brown;

Sand and gravel: 46RCNT coarse grained;

Shale: 37BKVD brown; weathered;

Shale: 37BKVD black; soft;

Site-ID : 33190001611

Nr on Map : G33611

* HydroGraph * Borehole log : Breede River Project

Coordinates : -73121.10 (E-W) 3742477.34 (N-S) 181.65 (Ground elevation)

Date Plotted: Oct 21 1991

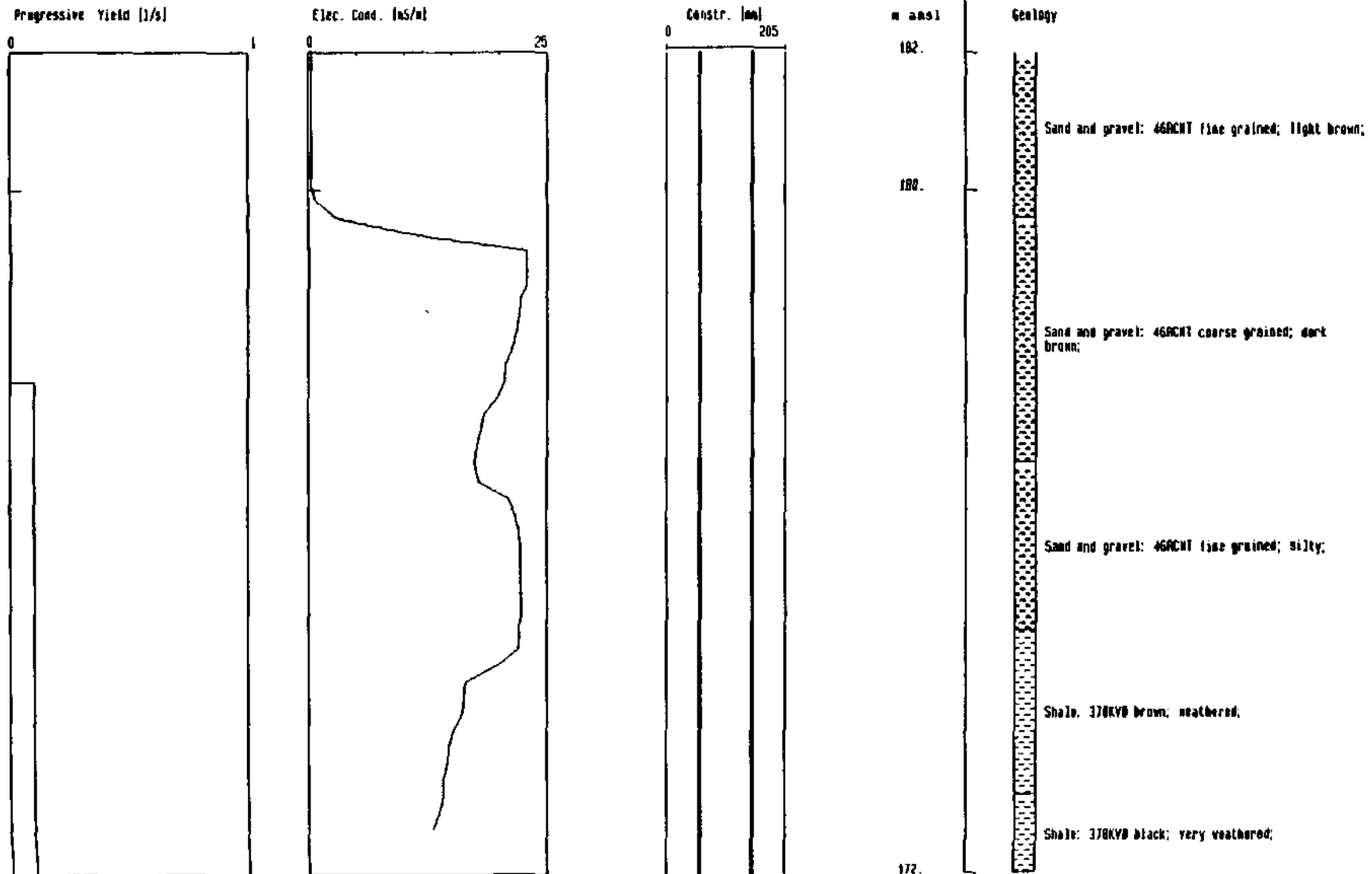

27

Site-ID : 33190001603

No on Map : 633603

* HydroGraph * Borehole log : Breede River Project

Coordinates : -33981.68 (E-W) 3742877.40 (N-S) 188.44 (Ground elevation)

Date Plotted: Oct 21 1991

Progressive Yield [l/s]

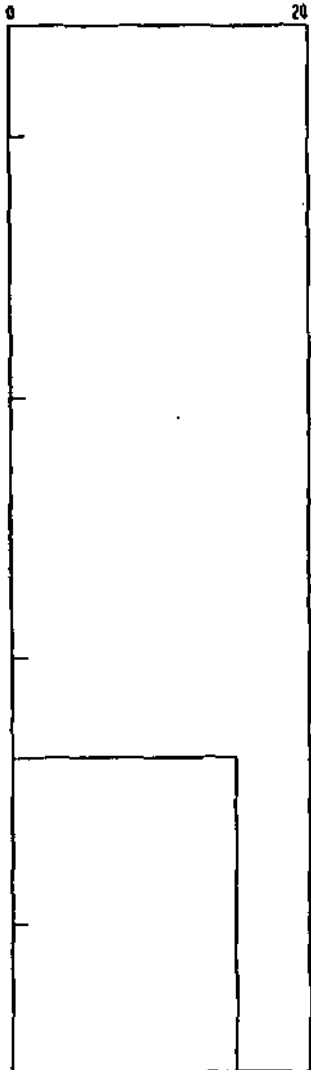

Elec. Cond. [uS/m]

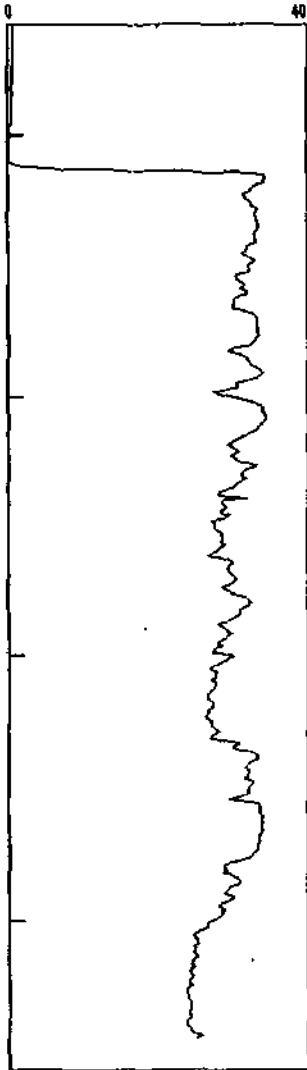

Constr. [mm]



m amsl



Geology

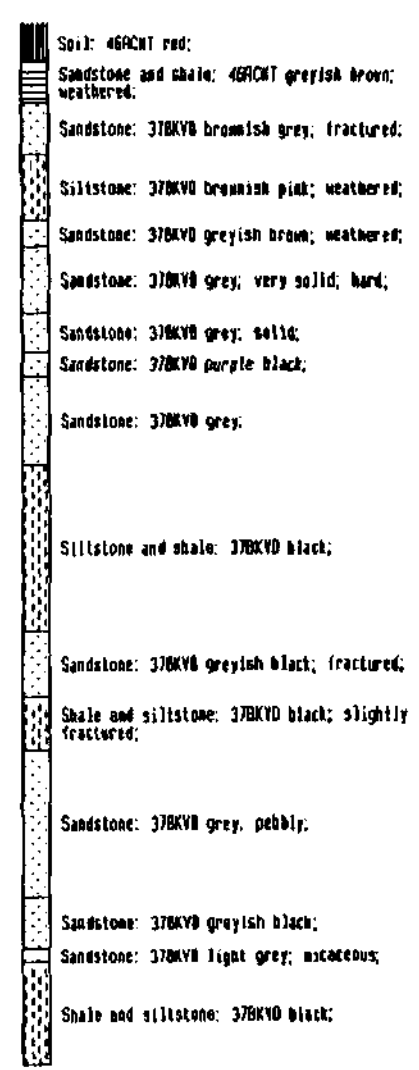

Appendix 3

Exploration boreholes:
Pumping test results

BREEDER RIVER : PUMPING TEST RESULTS

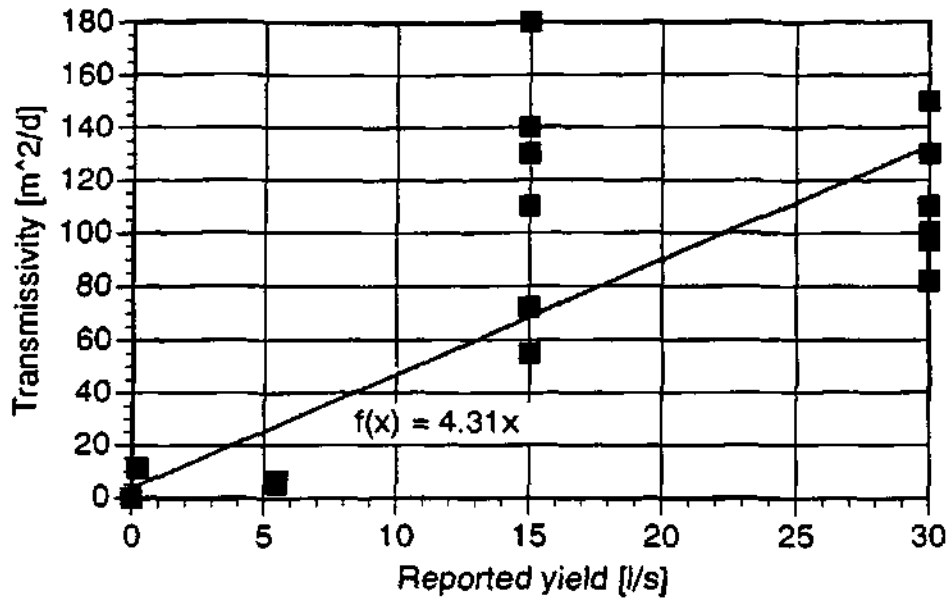

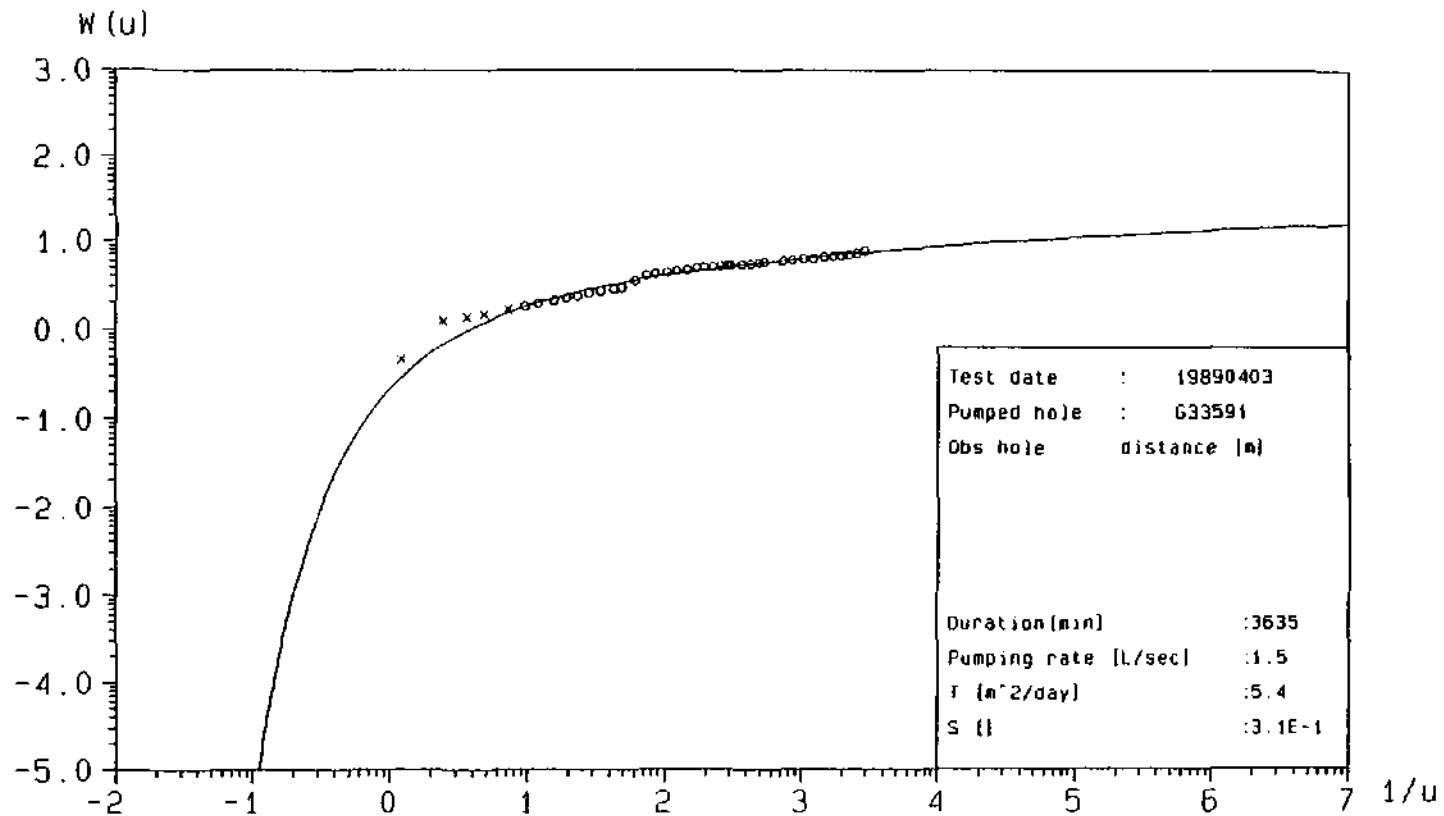

* HydroGraph - Theis pumping test analysis
Generated for : Breede River Project

* Site id : 3319DD00023
Date plotted : Nov 05 1991

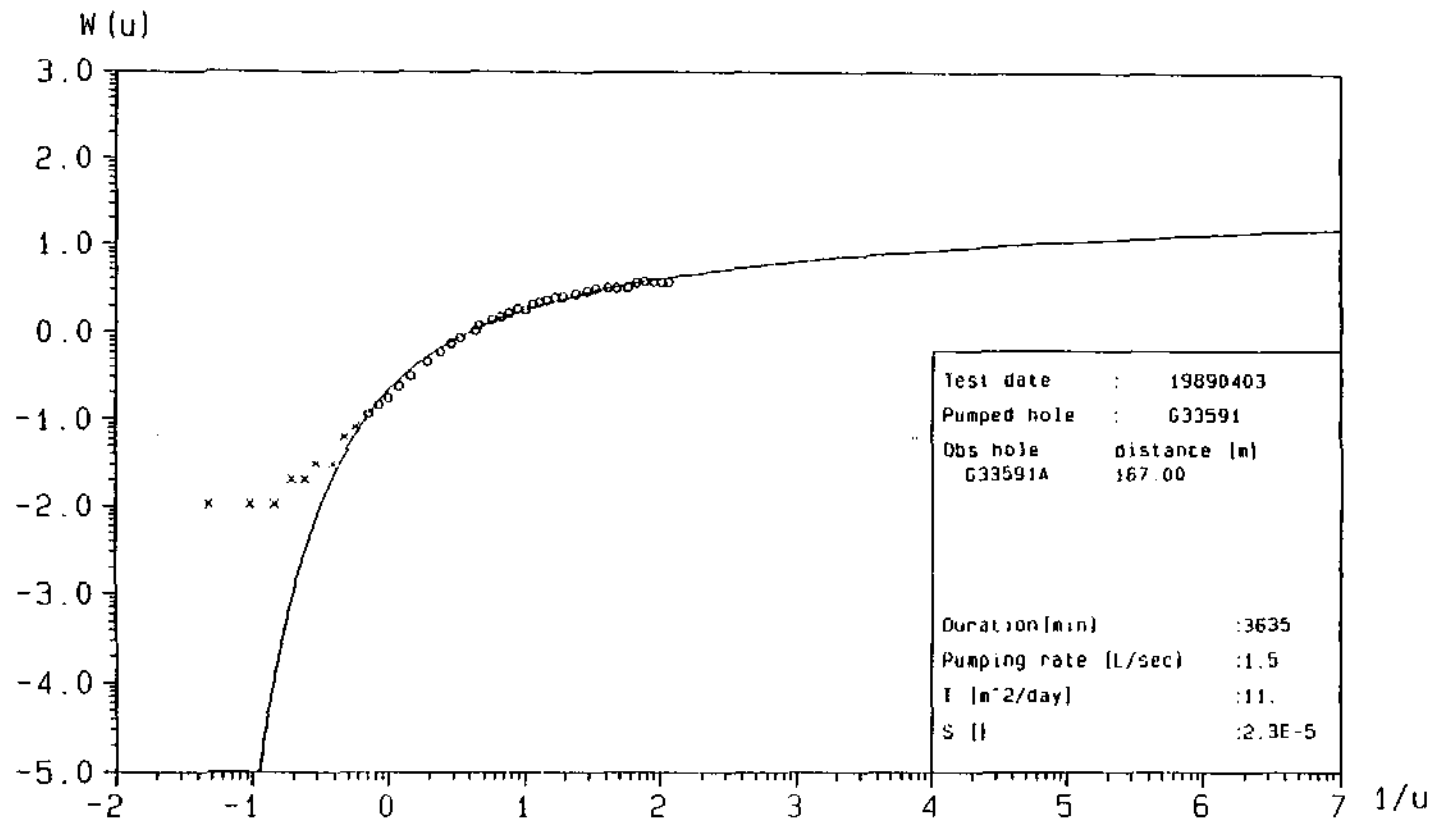

* HydroGraph - Theis pumping test analysis
Generated for : Breede River Project

* Site id : 33190000023
Date plotted : Nov 04 1991

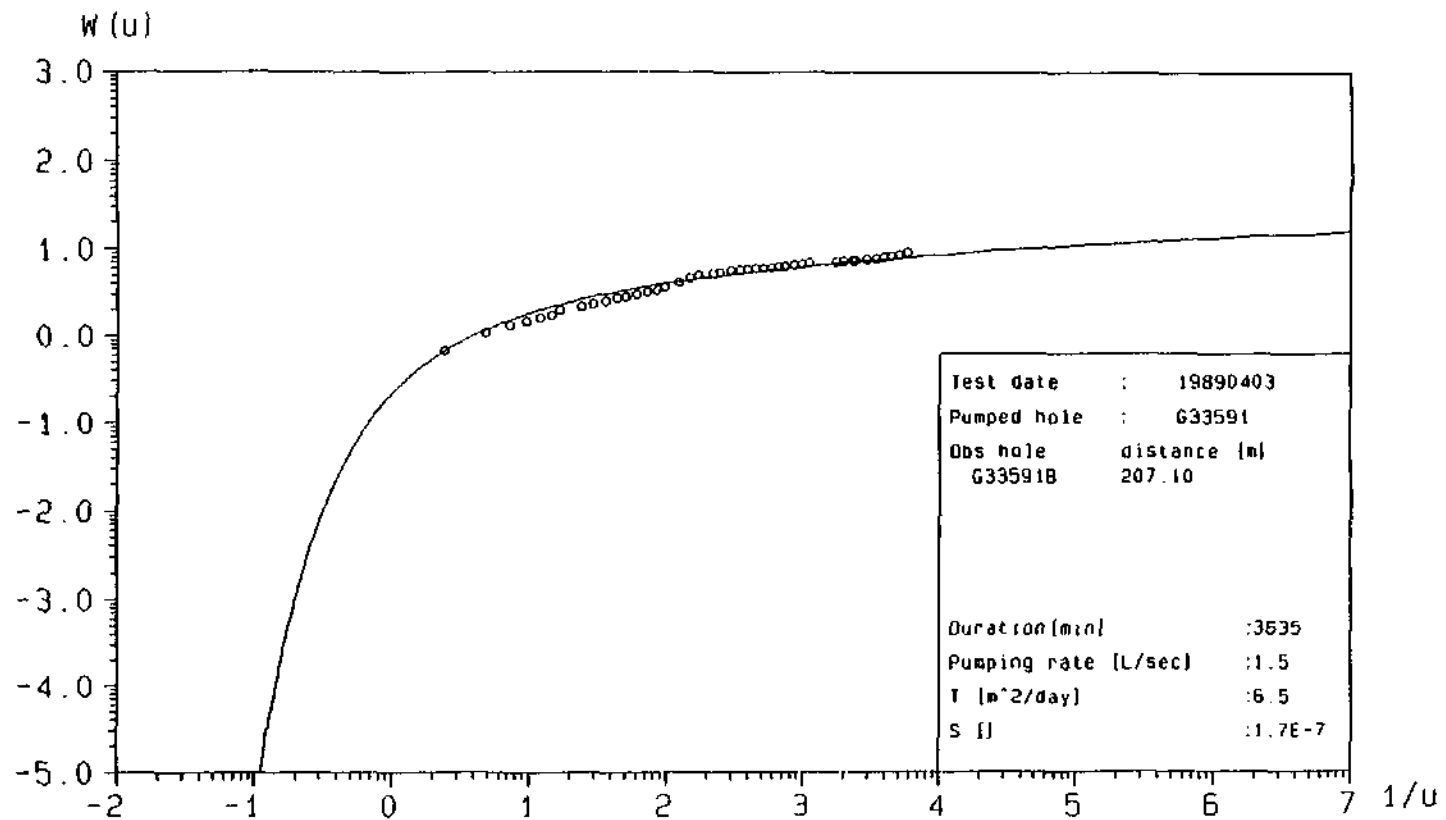

* HydroGraph - Theis pumping test analysis
Generated for : Breede River Project

* Site id : 3319DD00023
Date plotted : Nov 04 1991

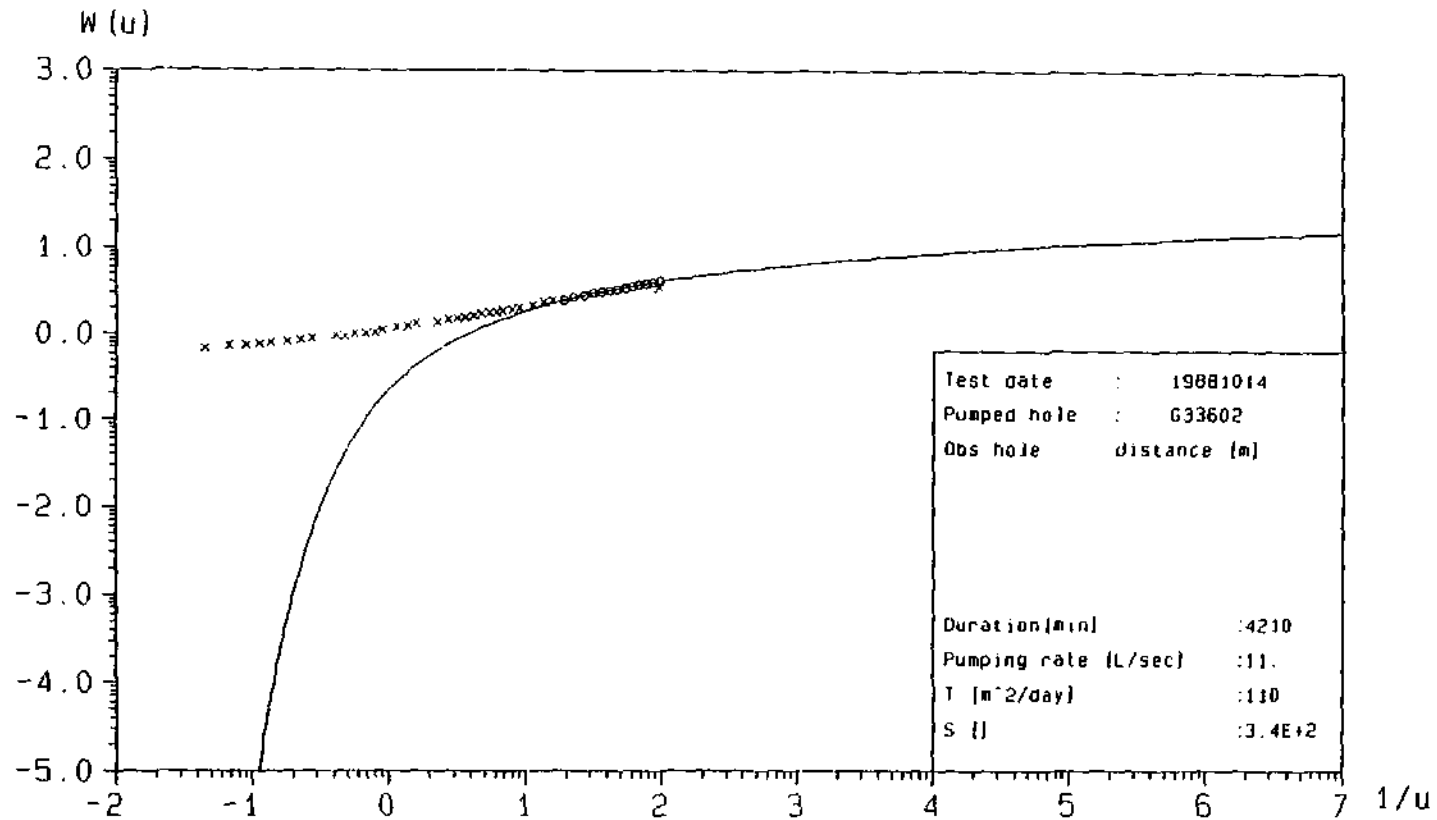

* HydroGraph - This pumping test analysis
Generated for : Breede River Project

* Site id : 3319DD01602
Date plotted : Nov 05 1991

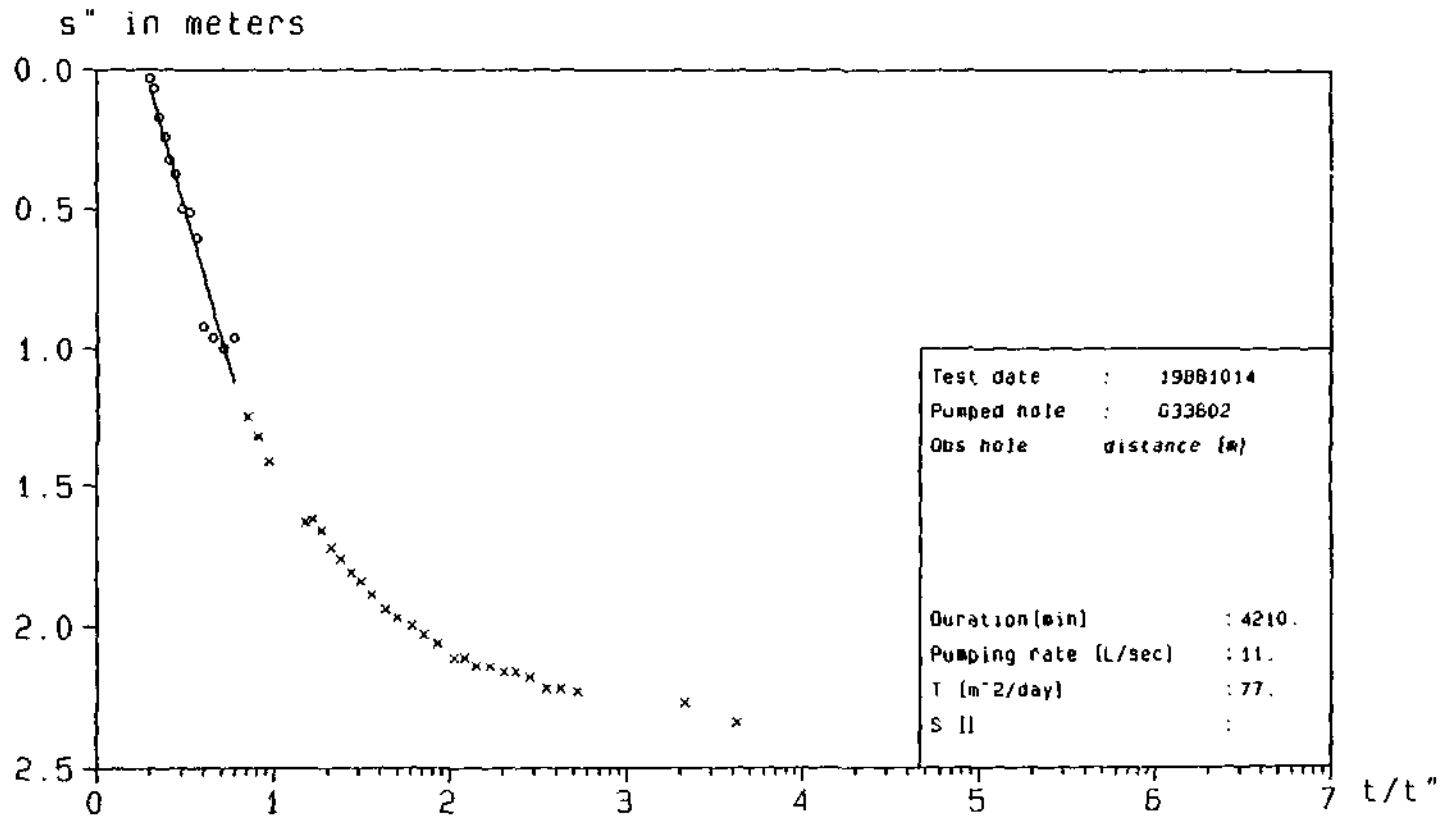

* HydroGraph - Theis recovery pumping test analysis * Site id : 3319DD01602
 Generated for : Breede River Project Date plotted : Nov 19 1991

I G S

Client: WATER RESEARCH COMMISSION

Project No.: Breede River Project

Location: Vink River

G 33602

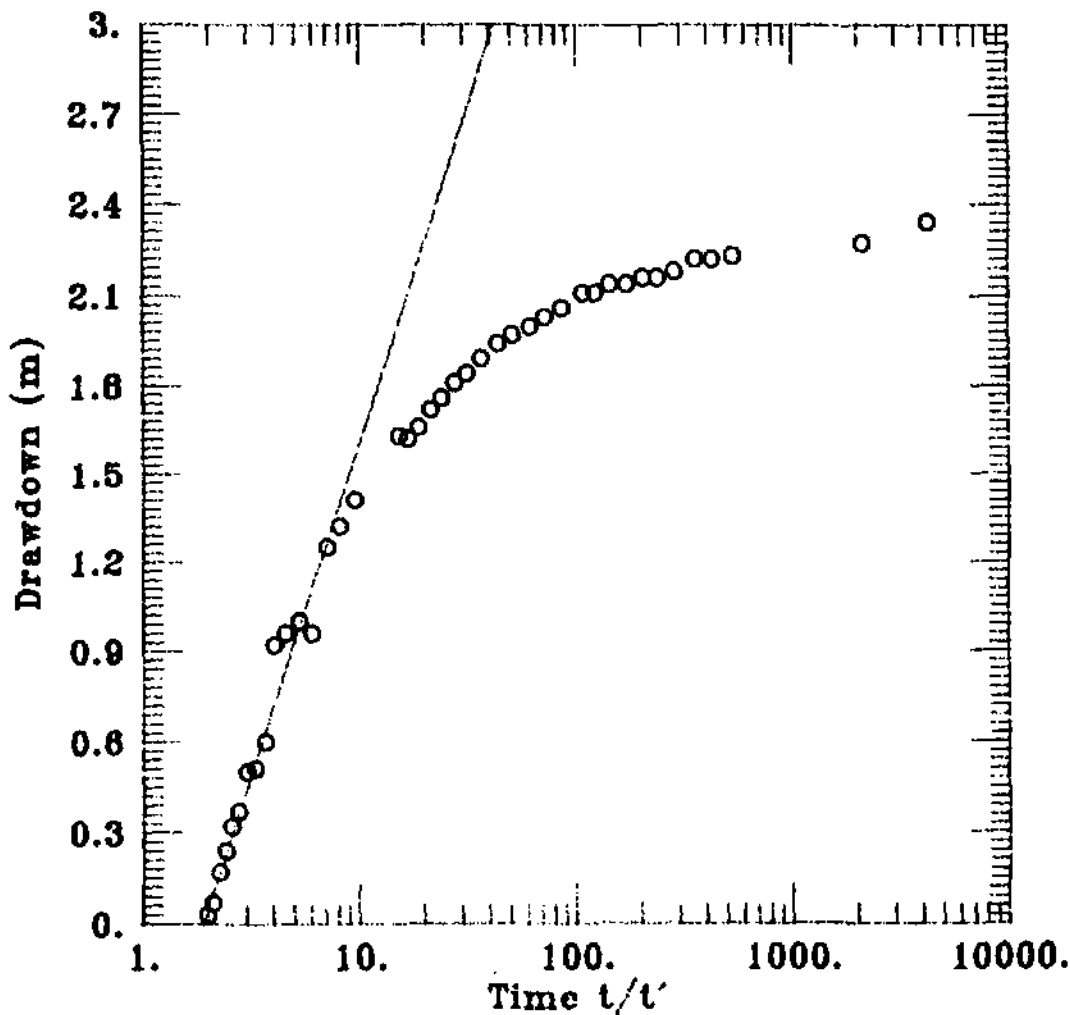

DATA SET:

G33602_R.DAT

11/16/91

AQUIFER TYPE:

Confined

SOLUTION METHOD:

Theis Recovery

TEST DATE:

14 October 1988

TEST WELL:

G 33602

OBS. WELL:

G 33602

ESTIMATED PARAMETERS:

$T = 78.34 \text{ m}^2/\text{day}$

$S' = 1.89$

TEST DATA:

$G = 950. \text{ m}^3/\text{day}$

$t \text{ pumping} = 2.924 \text{ days}$

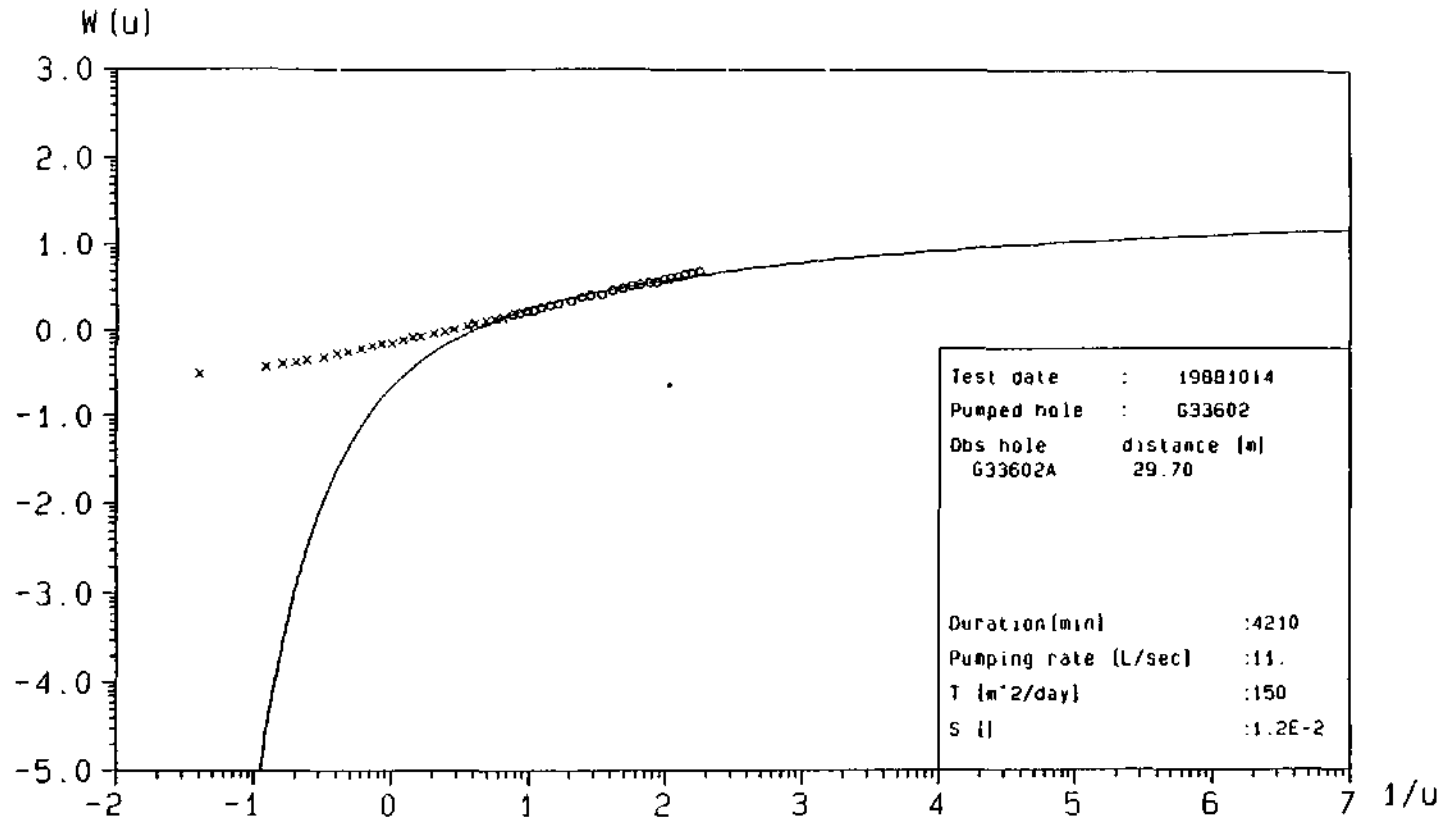

* HydroGraph - Theis pumping test analysis
Generated for : Breede River Project

* Site id : 3319DD01602
Date plotted : Nov 05 1991

G 33602A

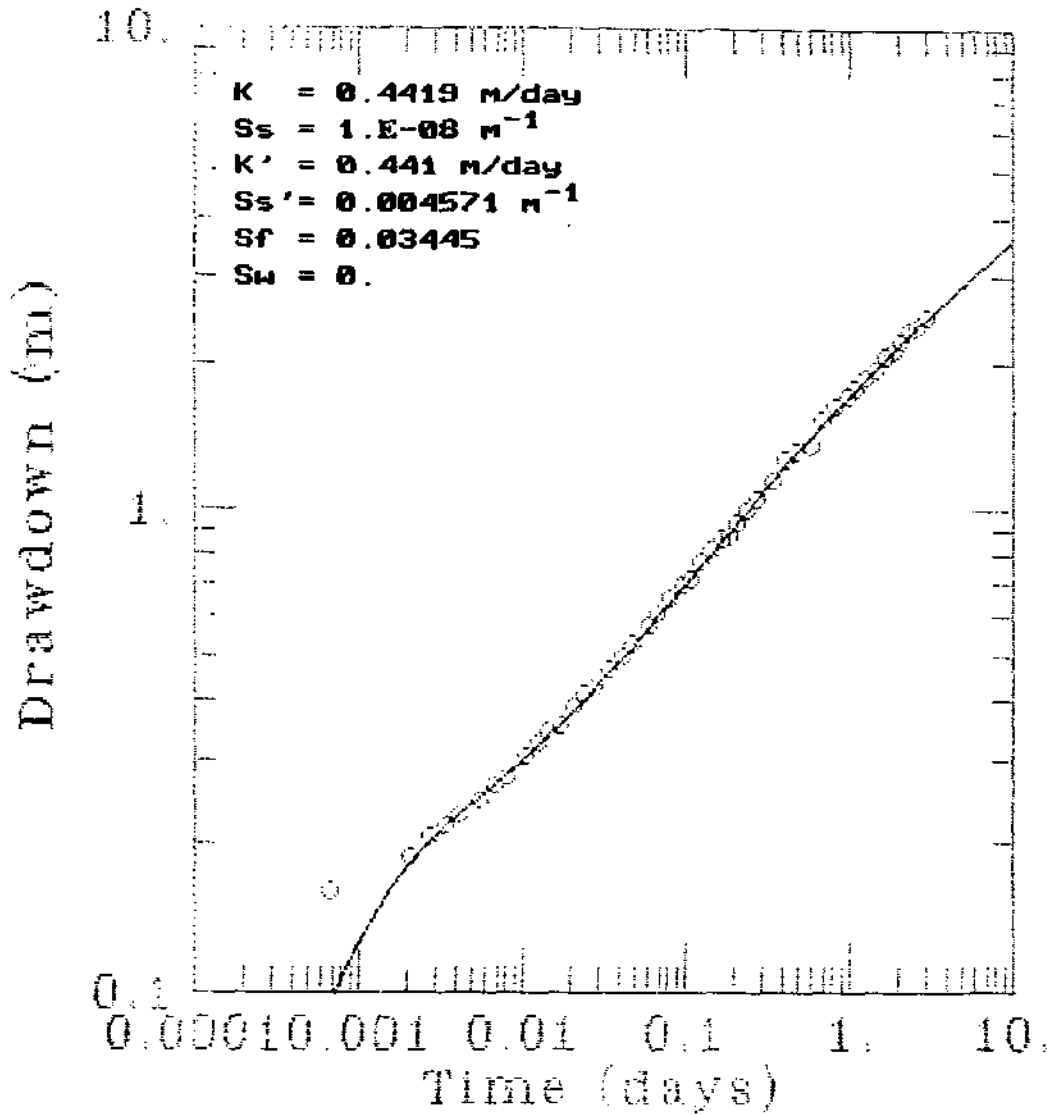

AQTESOLV



GERAGHTY
& MILLER, INC.

Modeling Group

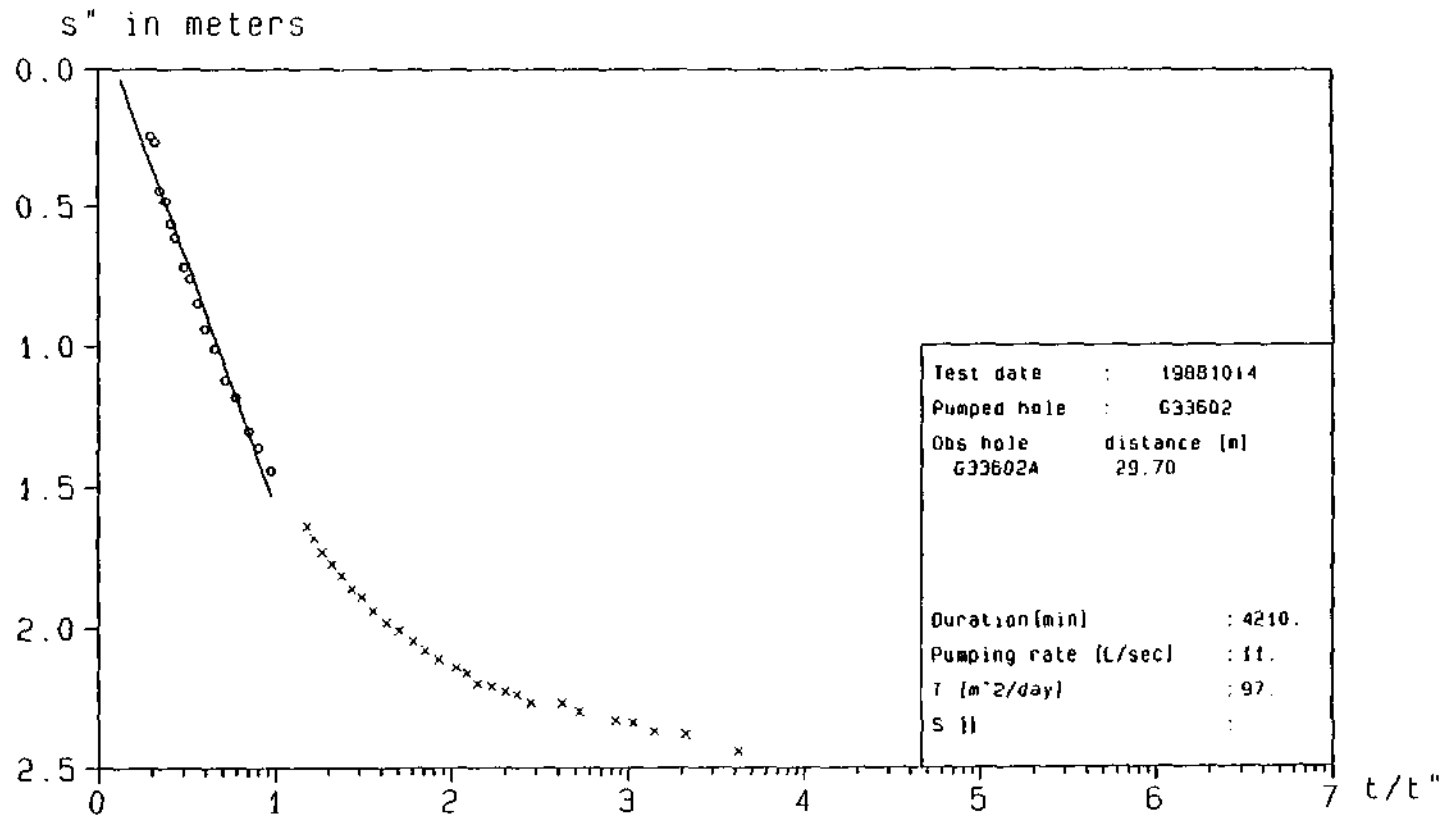

* HydroGraph - Theis recovery pumping test analysis * Site id : 3319D001602
 Generated for : Breede River Project Date plotted : Nov 05 1991

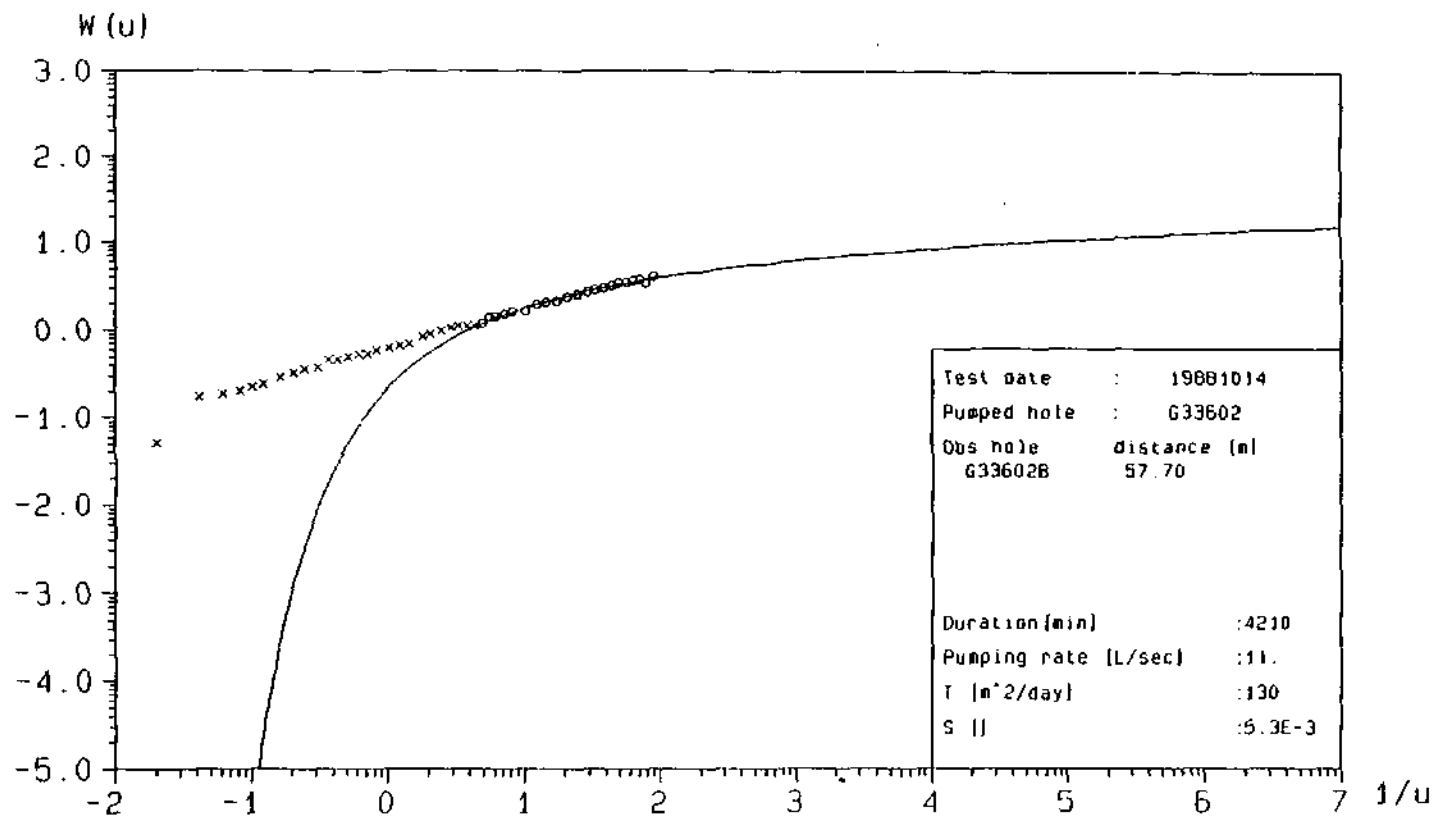

* HydroGraph - Theis pumping test analysis
Generated for : Breede River Project

* Site id : 3319DD01602
Date plotted : Nov 05 1991

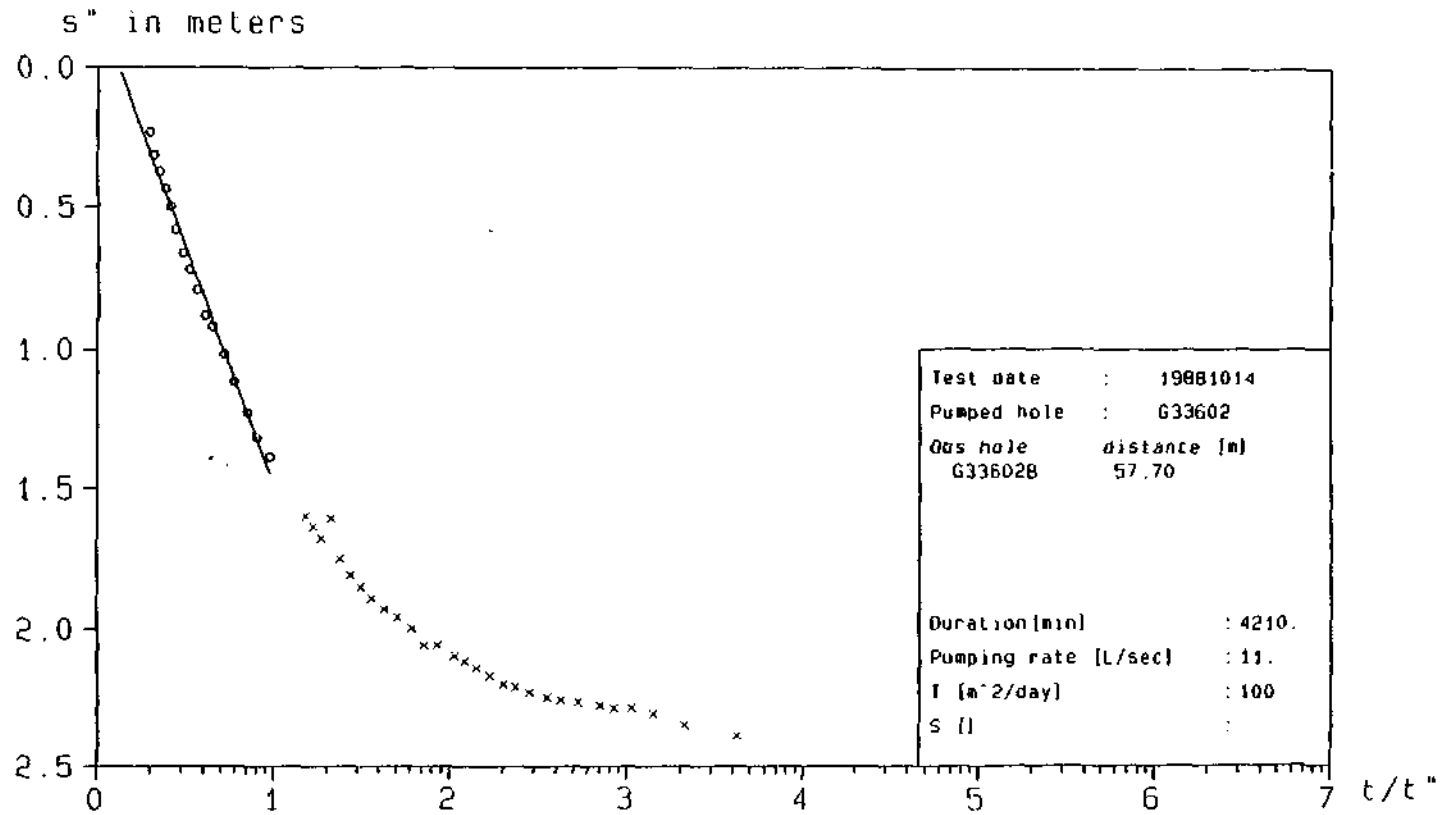

* HydroGraph - Theis recovery pumping test analysis * Site id : 33190001602
 Generated for : Breede River Project Date plotted : Nov 05 1991

----- I G S -----

Client: WATER RESEARCH COMMISSION

Project No.: Breede River Project

Location: Vink River

G 33603

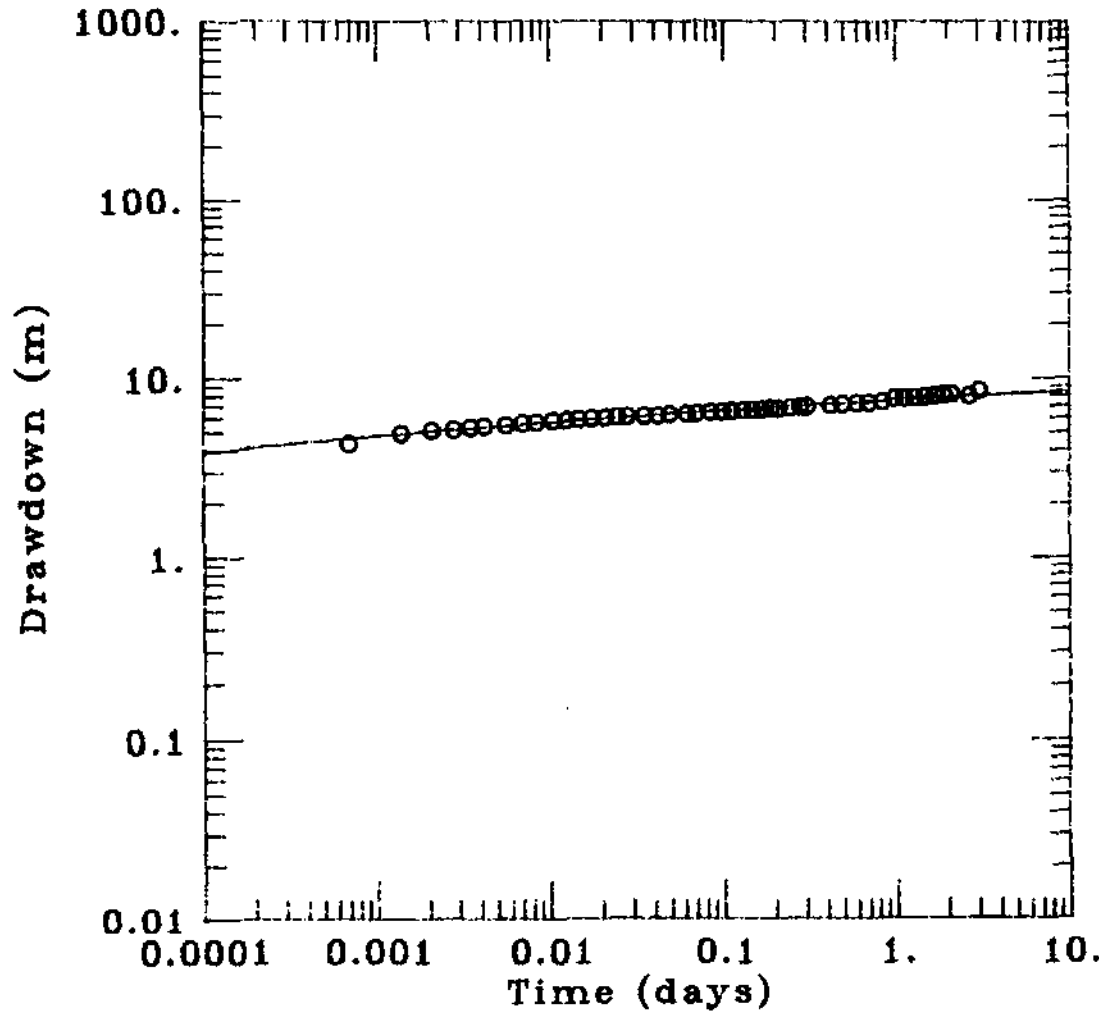

DATA SET:
G33603.DAT
11/07/91

AQUIFER TYPE:
Confined
SOLUTION METHOD:
Theis
TEST DATE:
28 September 1988
TEST WELL:
G 33603
OBS. WELL:
G 33603

ESTIMATED PARAMETERS:
 $T = 165.8 \text{ m}^2/\text{day}$
 $S = 0.0002198$

TEST DATA:
 $Q = 830. \text{ m}^3/\text{day}$
 $r = 0.102 \text{ m}$

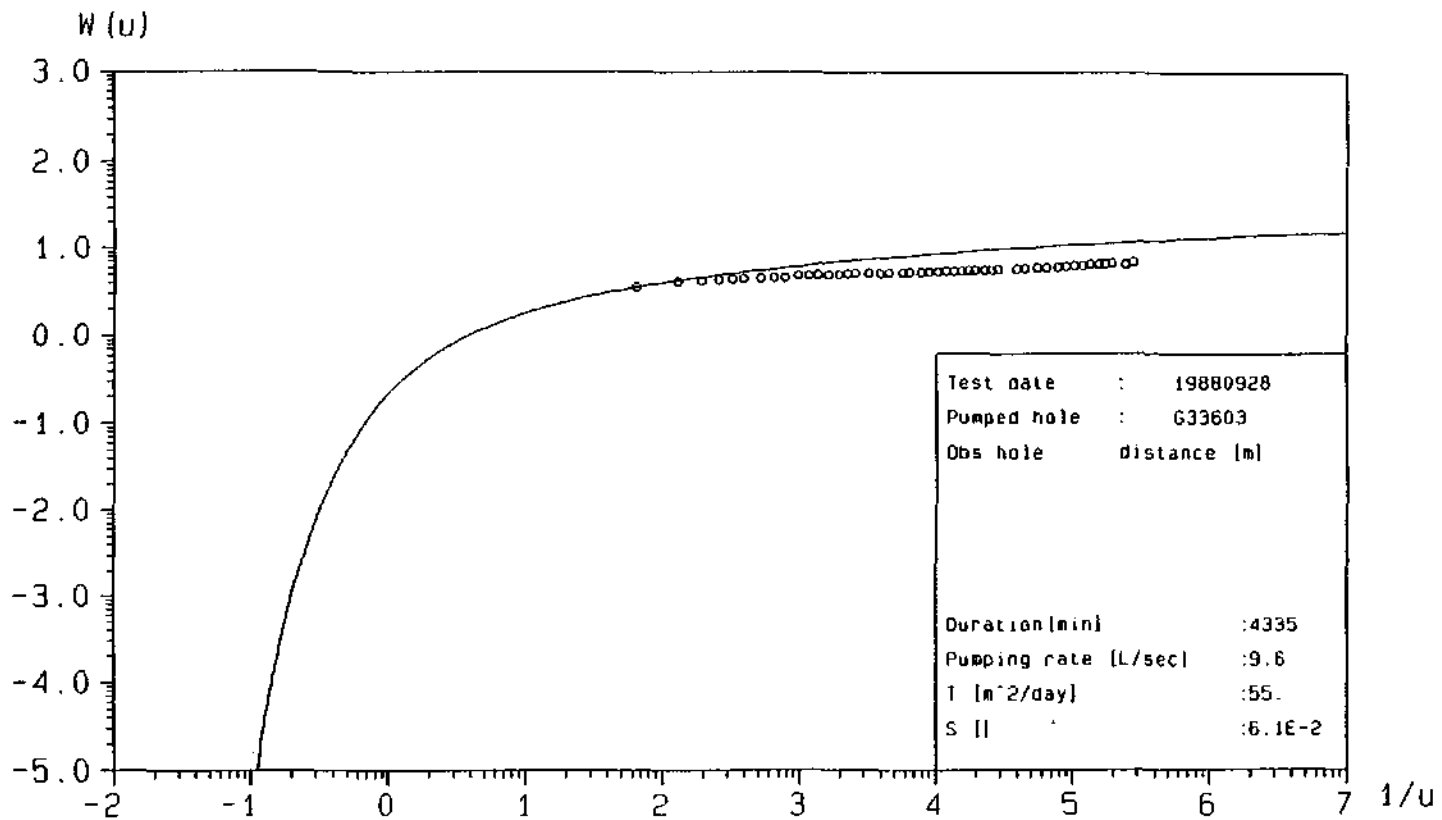

* HydroGraph - Theis pumping test analysis
Generated for : Breede River Project

* Site id : 3319DD01603
Date plotted : Nov 05 1991

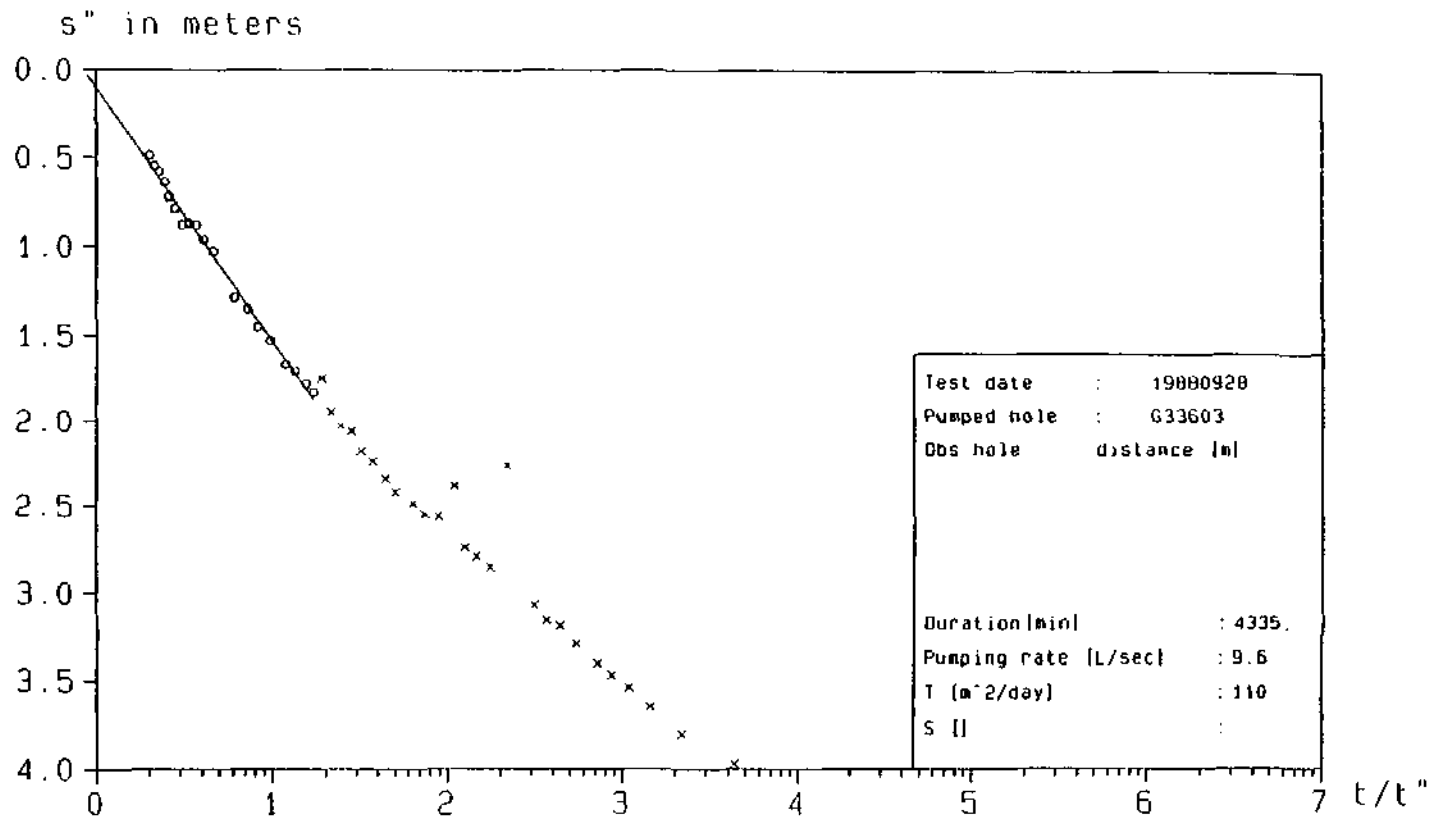

* HydroGraph - This recovery pumping test analysis * Site id : 3319DD01603
 Generated for : Breede River Project Date plotted : Nov 05 1991

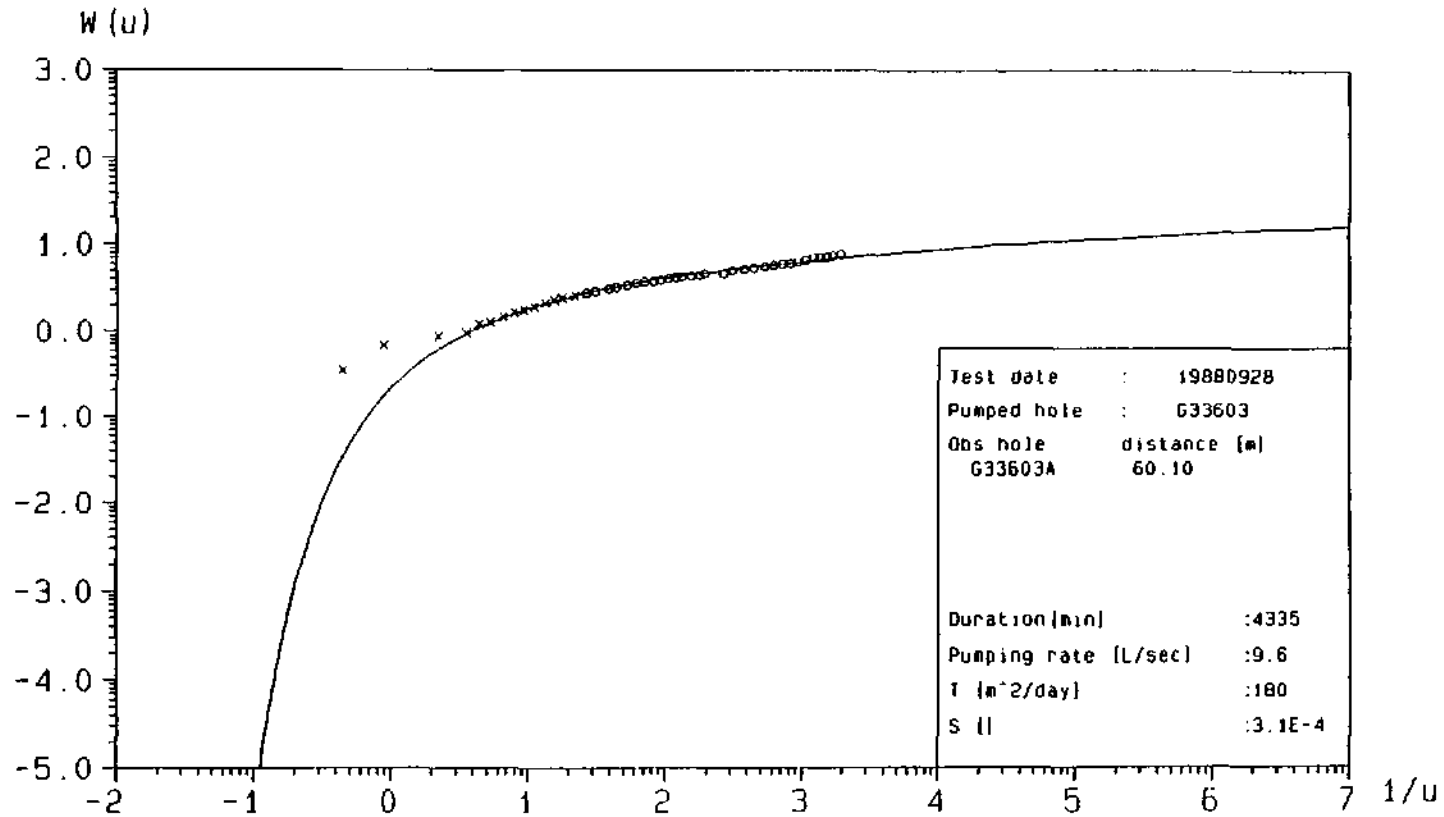

* HydroGraph - This pumping test analysis
Generated for : Breede River Project

* Site id : 33190001603
Date plotted : Nov 18 1991

I G S

Project No.: Breede River Project

G 33603A

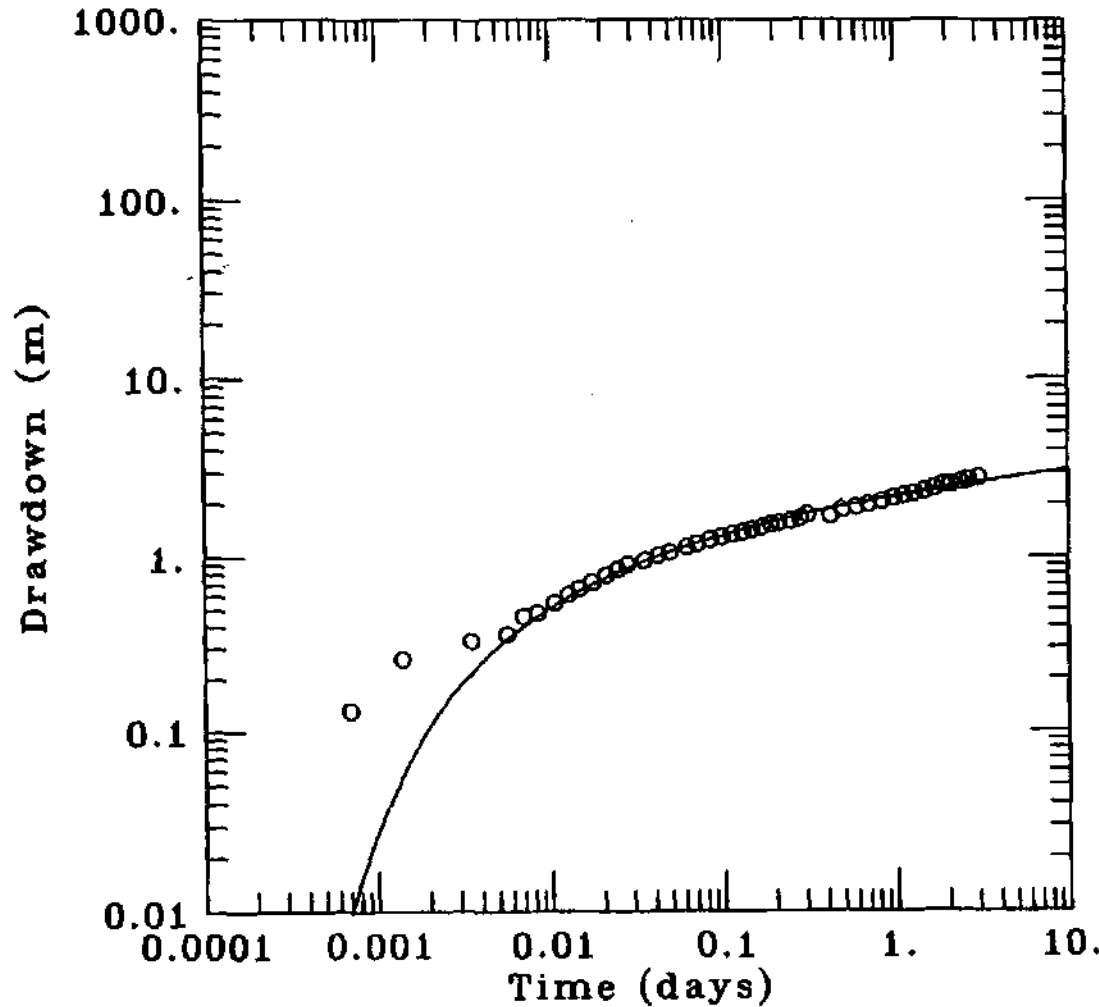

DATA SET:

G33603A.DAT

11/06/91

AQUIFER TYPE:

Confined

SOLUTION METHOD:

Theis

TEST DATE:

27 Sep. 1988

TEST WELL:

G 33603

OBS. WELL:

G 33603A

ESTIMATED PARAMETERS:

$T = 172.7 \text{ m}^2/\text{day}$

$S = 0.0003284$

TEST DATA:

$Q = 830. \text{ m}^3/\text{day}$

$r = 60.1 \text{ m}$

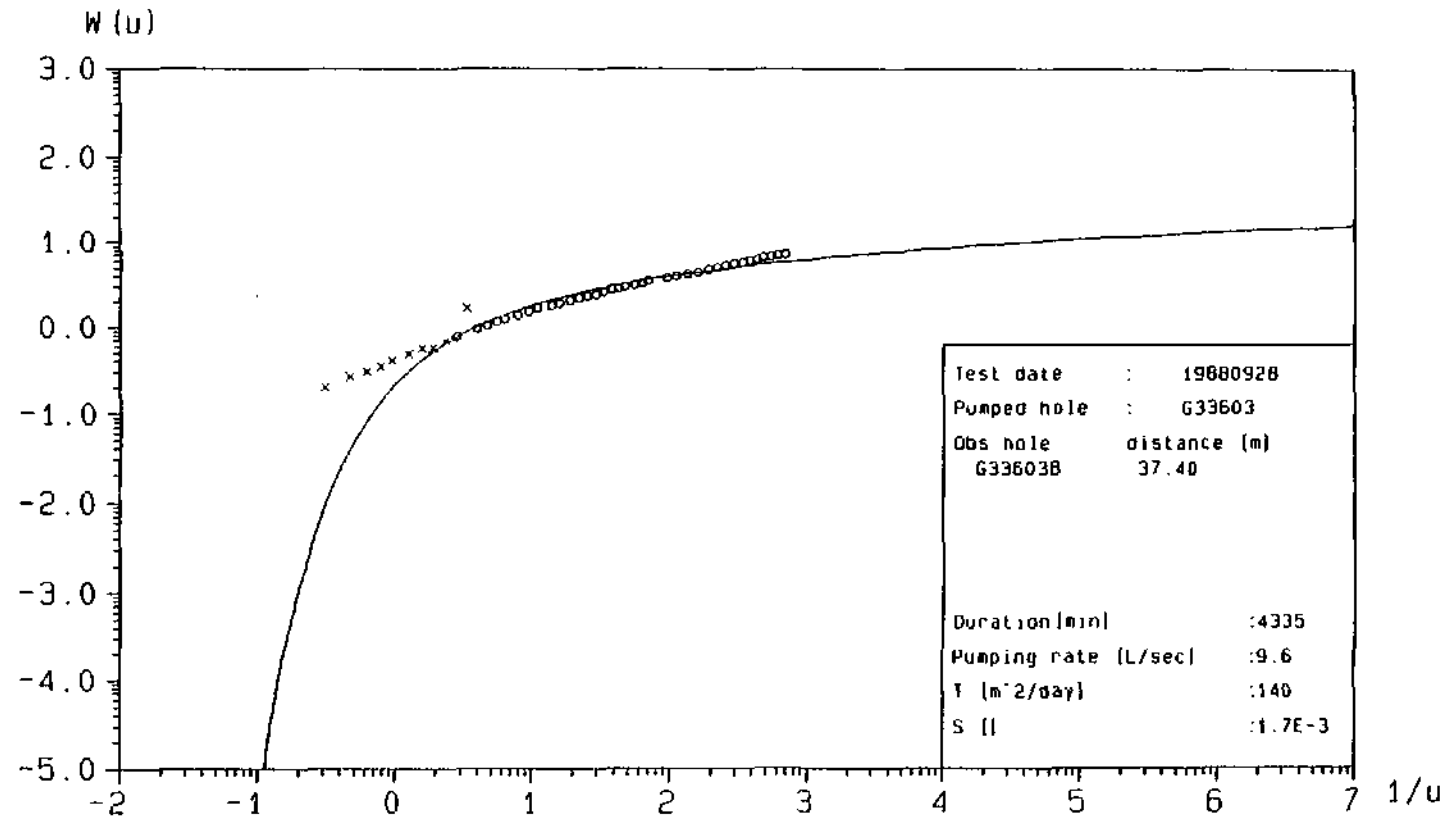

* HydroGraph - This pumping test analysis
Generated for : Breede River Project

* Site id : 3319DD01603
Date plotted : Nov 04 1991

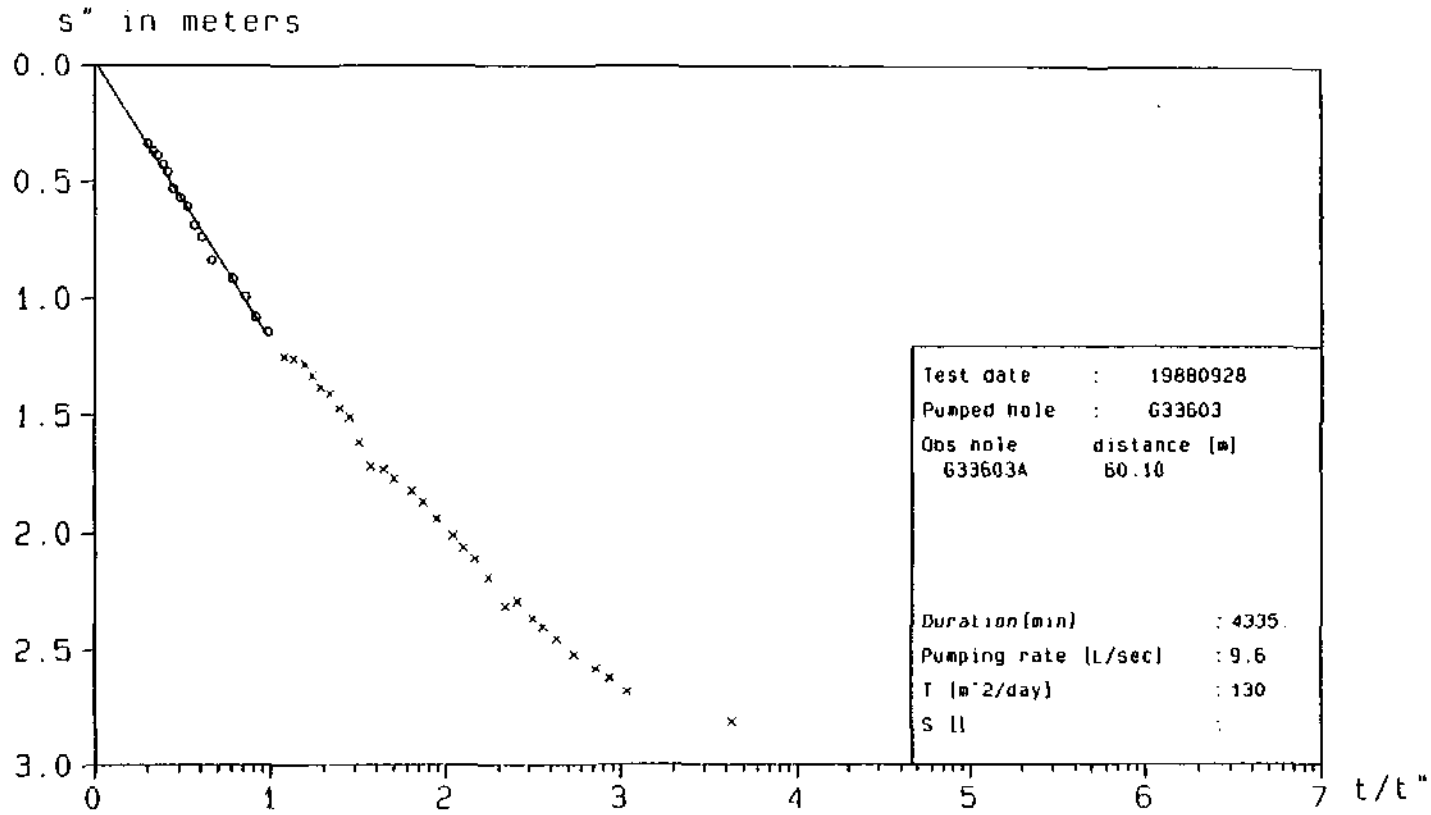

* HydroGraph - Theis recovery pumping test analysis * Site id : 3319DD01603
 Generated for : Breede River Project . Date plotted : Nov 05 1991

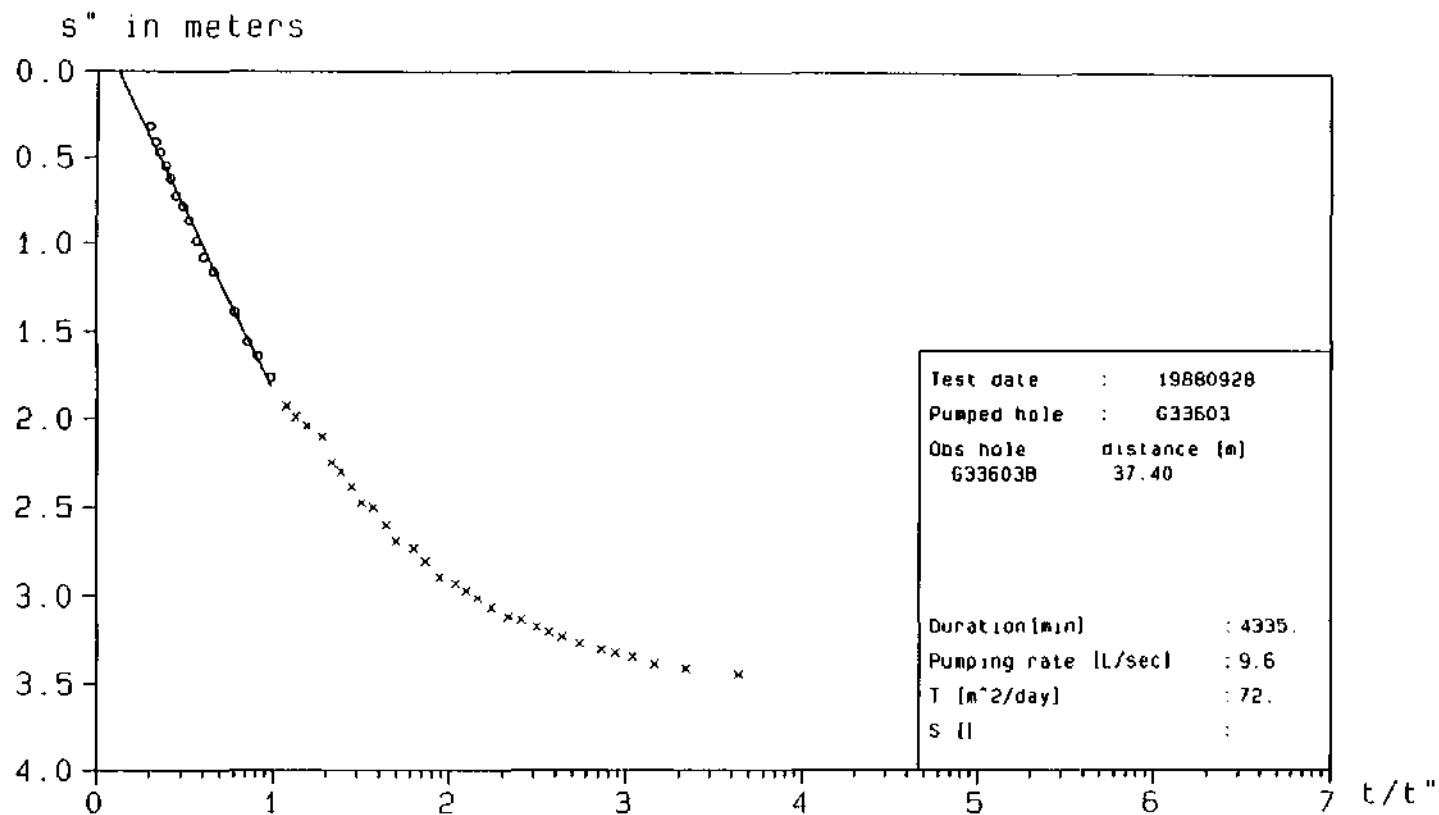

* HydroGraph - Theis recovery pumping test analysis * Site id : 33190001603
 Generated for : Breede River Project Date plotted : Nov 05 1991

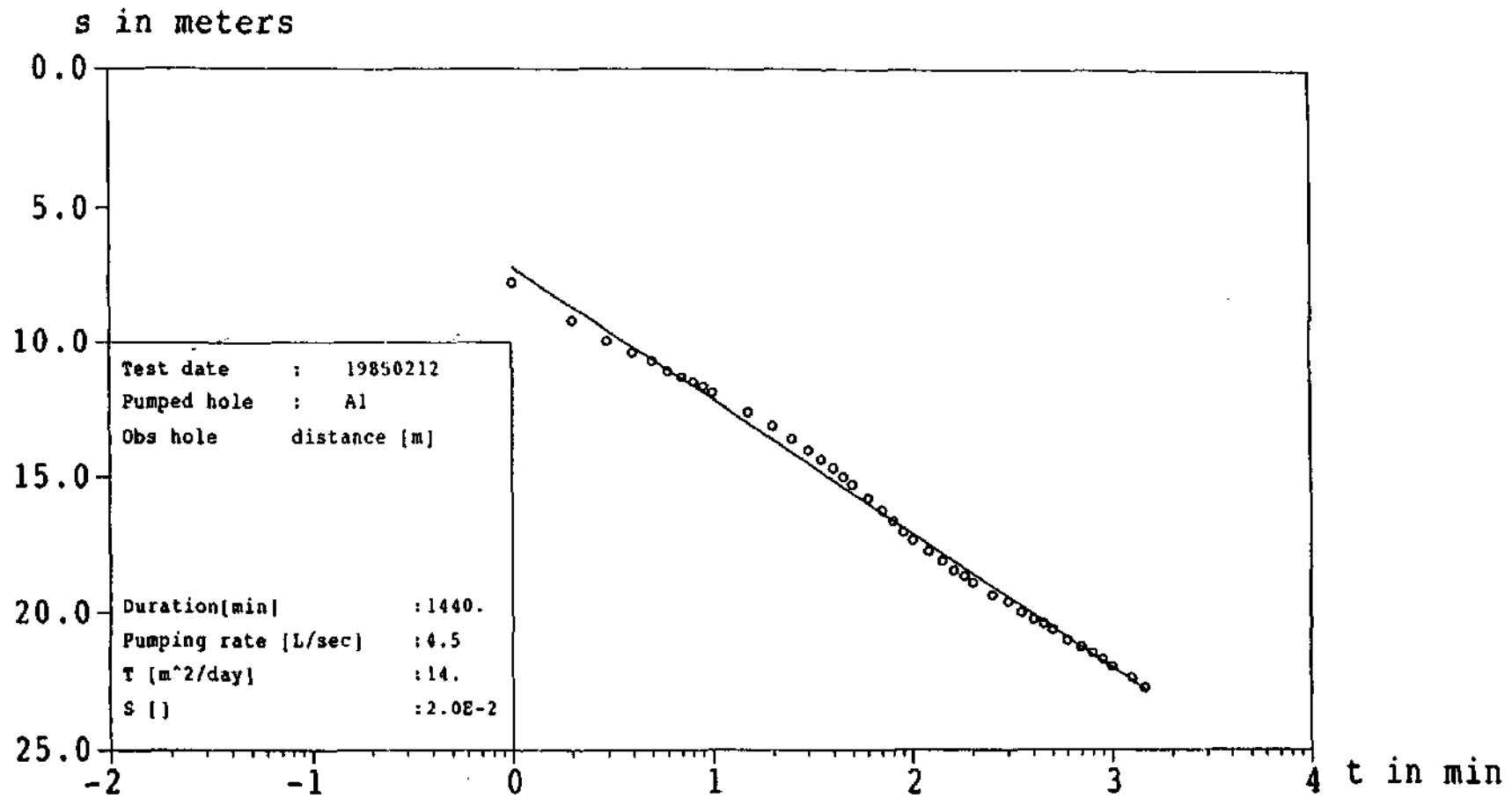

* HydroGraph - Cooper Jacob pumping test analysis
 Generated for : Breede River Project

* Site id : 3319DC00210
 Date plotted : Jan 02 1992

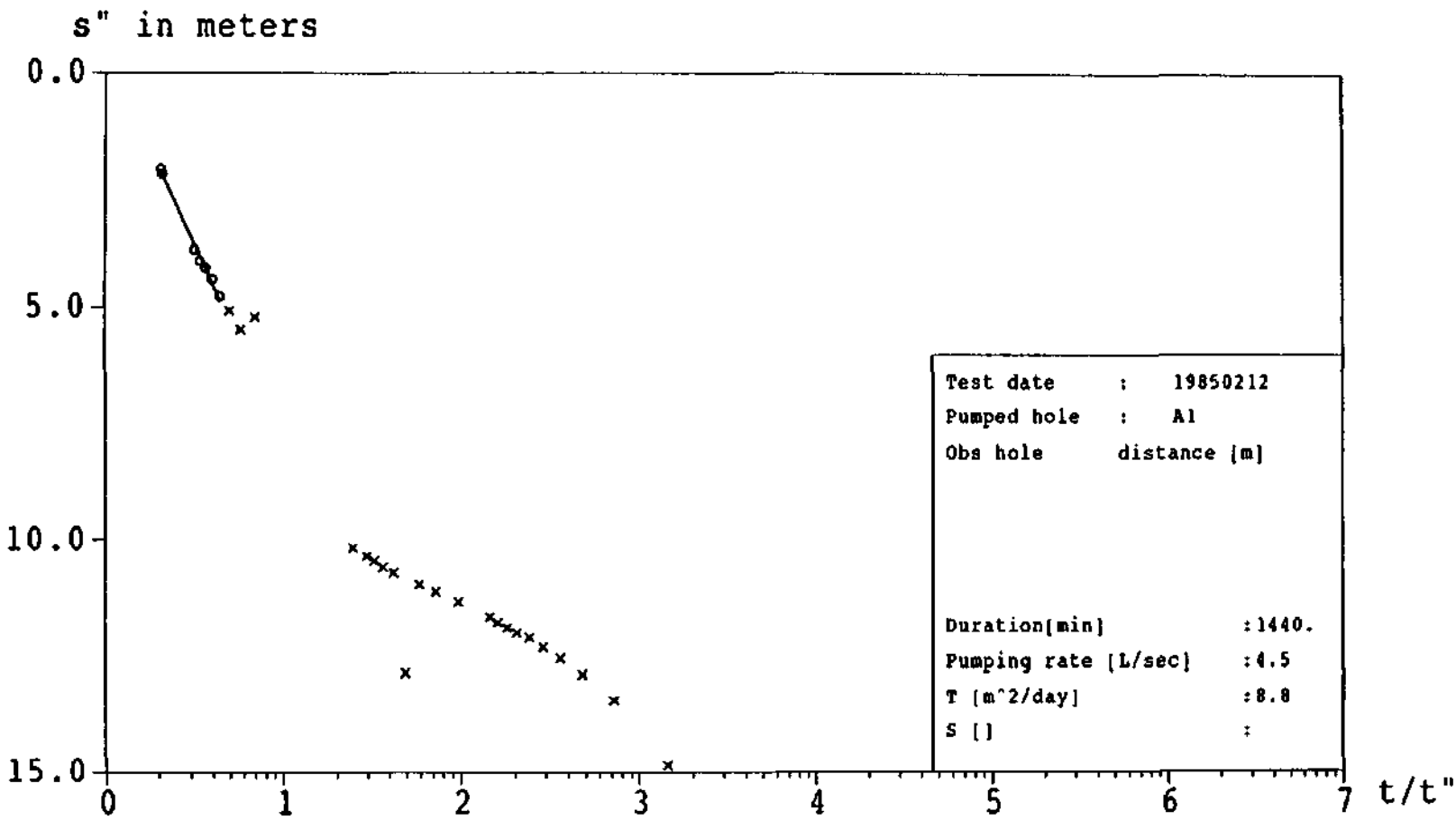

* HydroGraph - Theis recovery pumping test analysis * Site id :3319DC00210
 Generated for : Breede River Project Date plotted : Jan 02 1992

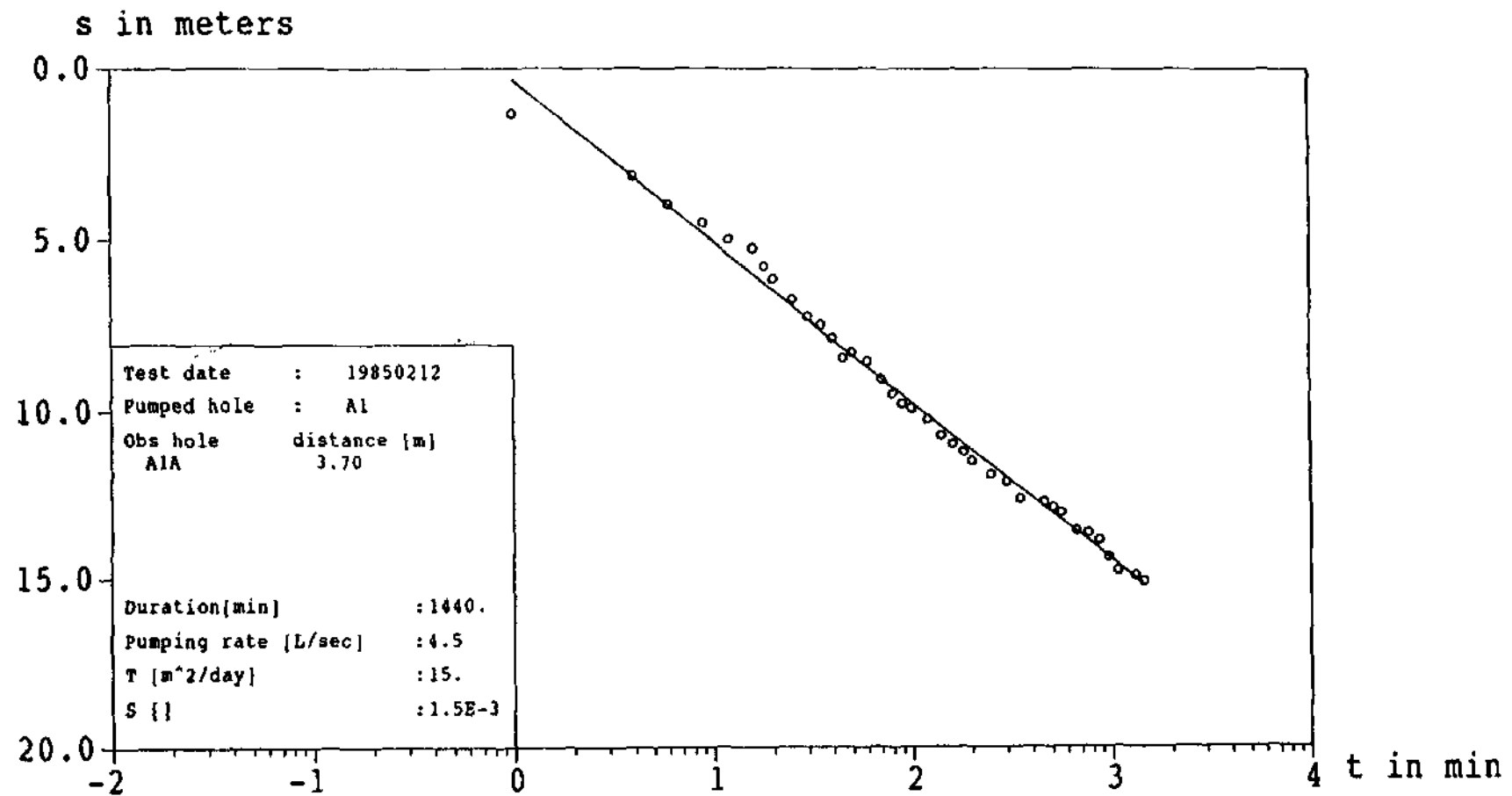

* HydroGraph - Cooper Jacob pumping test analysis
Generated for : Breede River Project

* Site id : 3319DC00210
Date plotted : Jan 02 1992

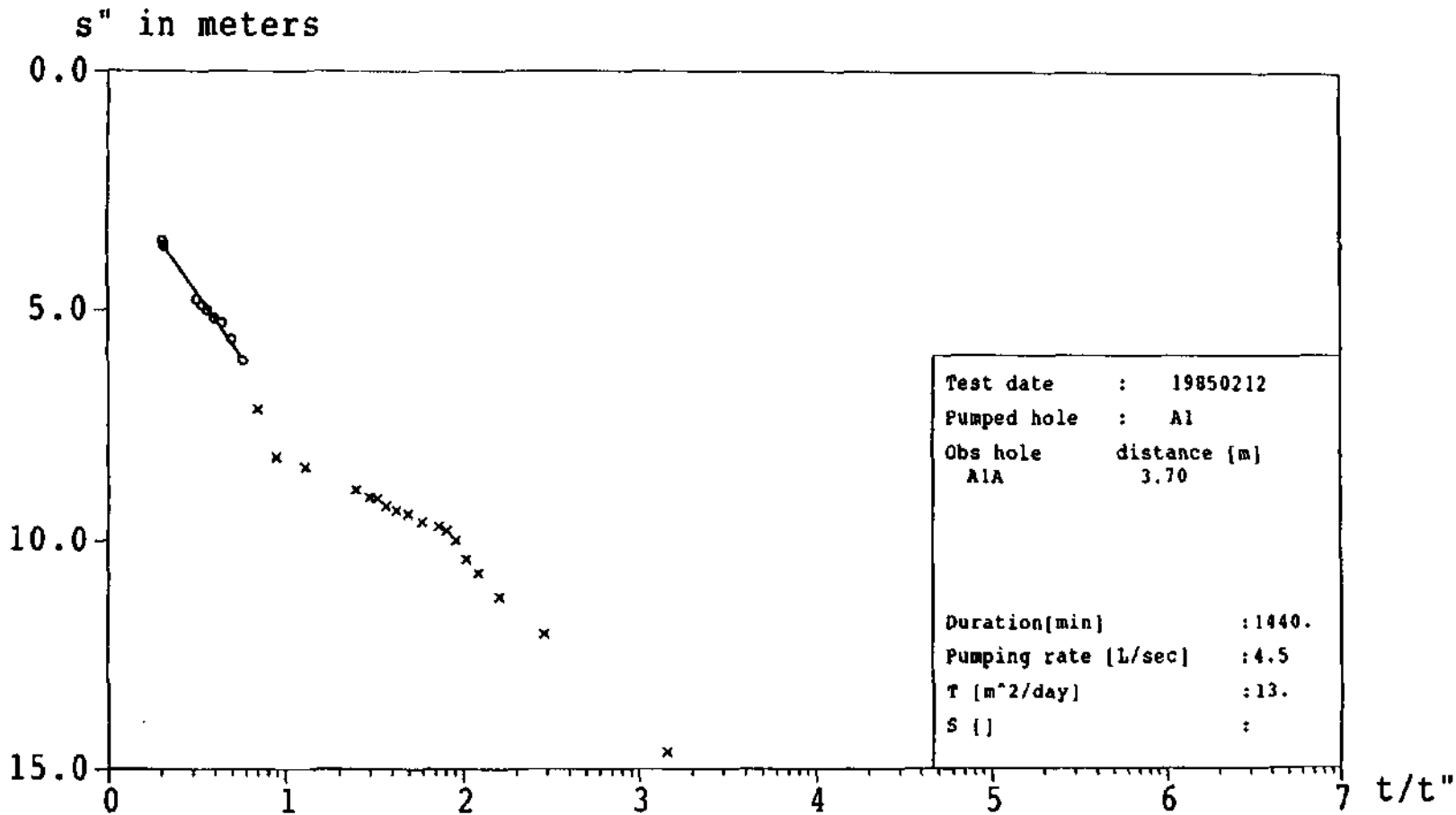

* HydroGraph - This recovery pumping test analysis * Site id :3319DC00210
 Generated for : Breede River Project Date plotted : Jan 02 1992

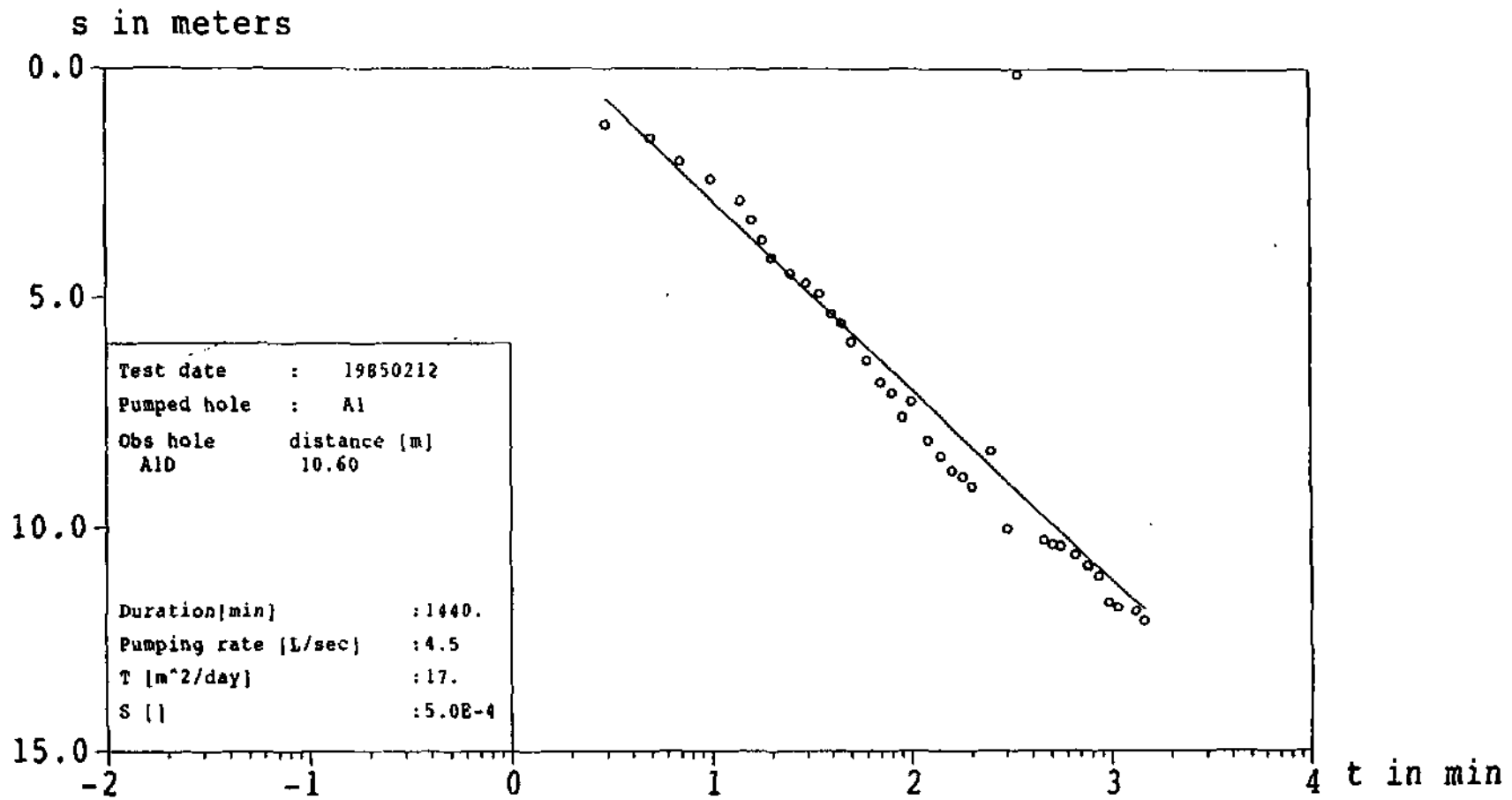

* HydroGraph - Cooper Jacob pumping test analysis
 Generated for : Breede River Project

* Site id : 3319DC00210
 Date plotted : Jan 02 1992

54

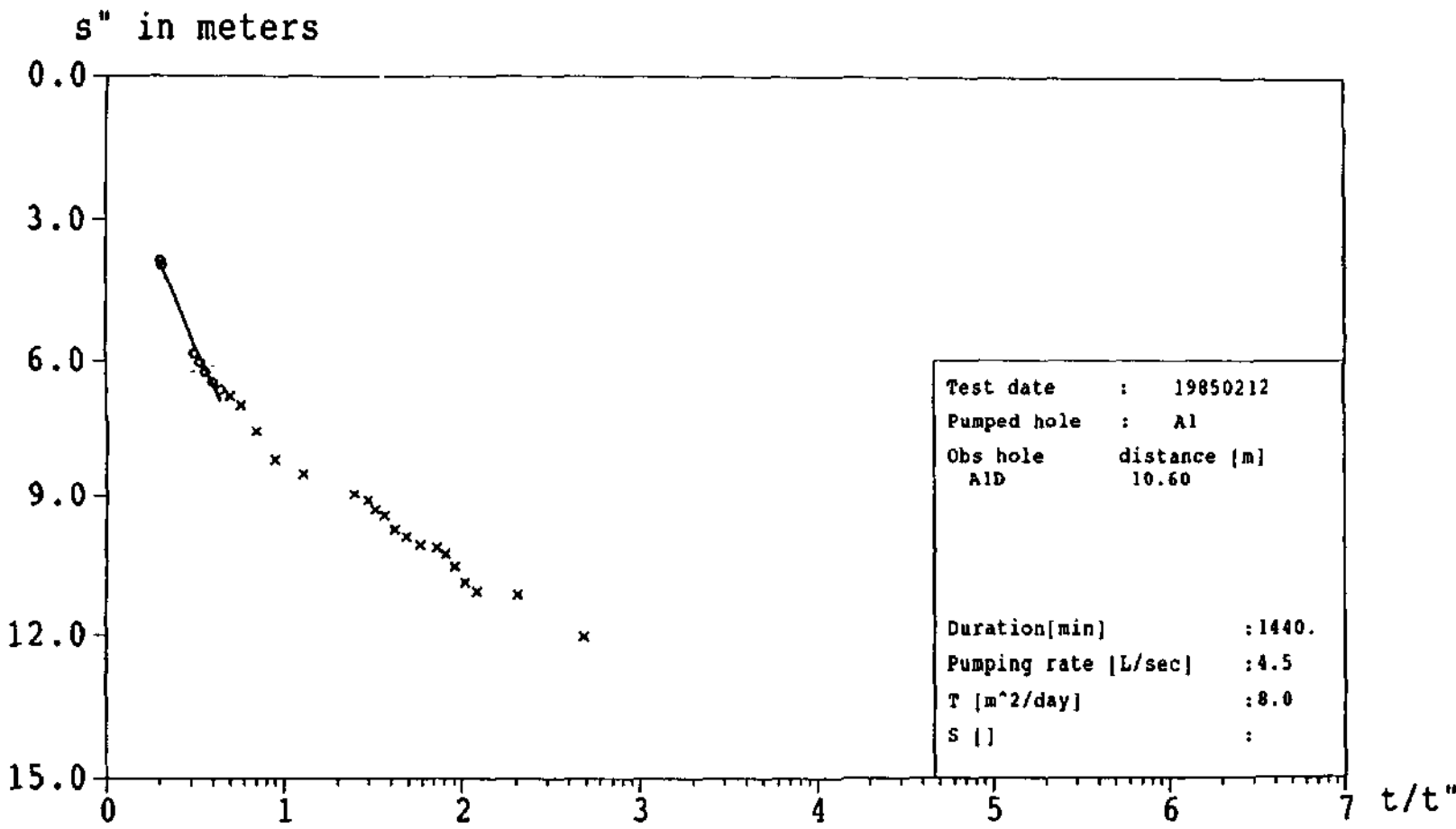

* HydroGraph - Theis recovery pumping test analysis * Site id : 3319DC00210
 Generated for : Breede River Project Date plotted : Jan 02 1992

SS

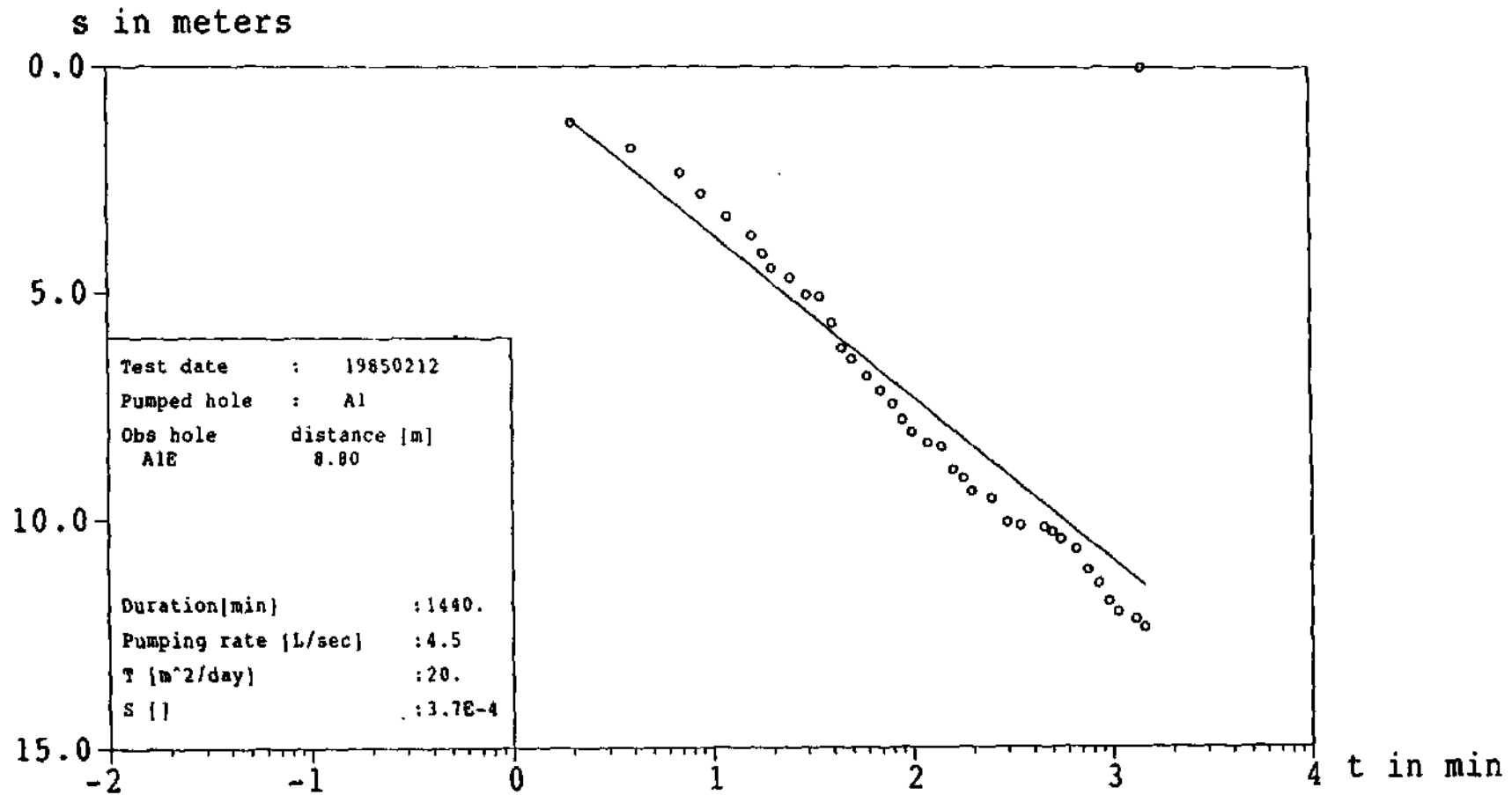

* HydroGraph - Cooper Jacob pumping test analysis
 Generated for : Breede River Project

* Site id :3319DC00210
 Date plotted : Jan 02 1992

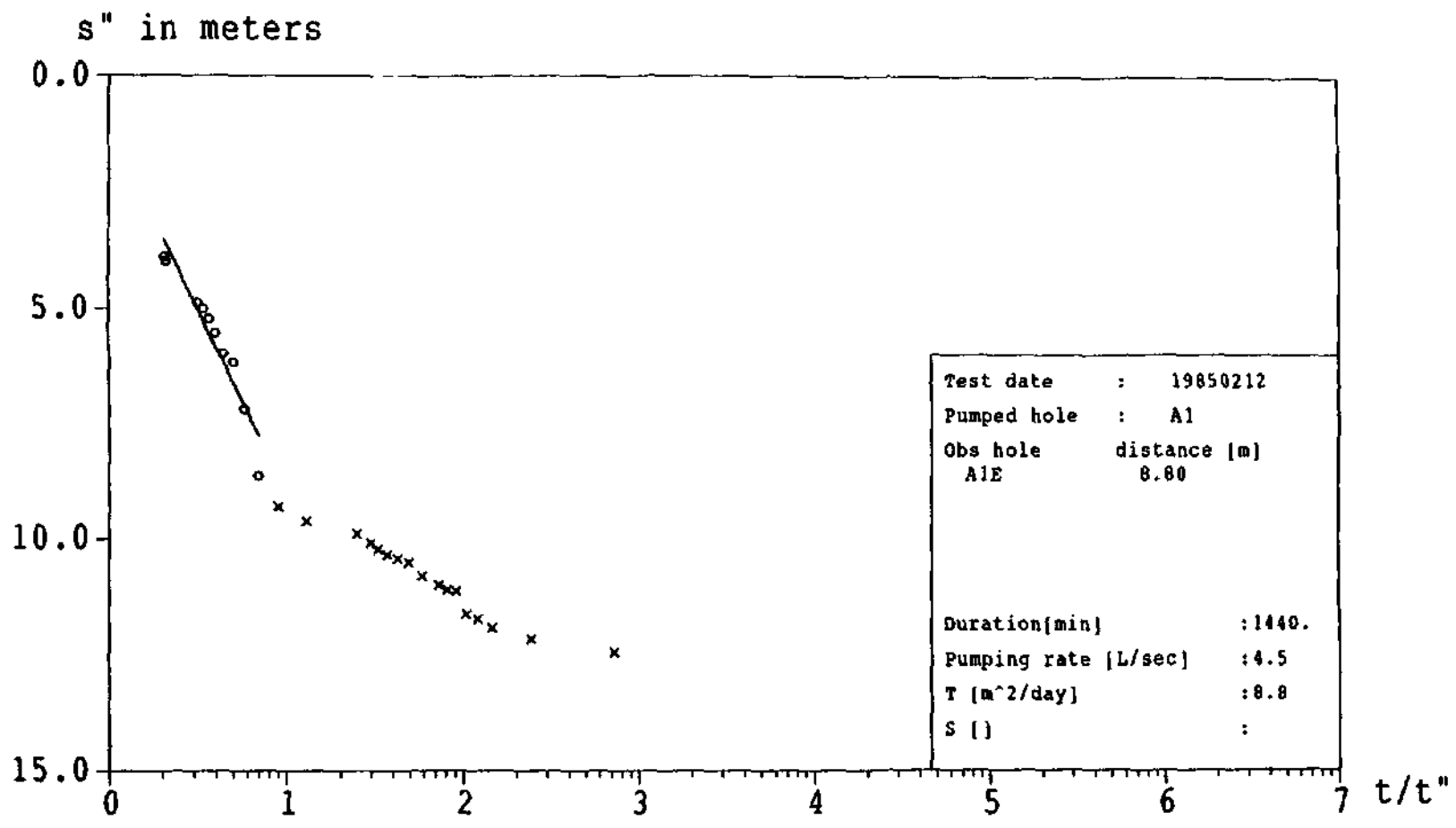

* HydroGraph - This recovery pumping test analysis * Site id : 3319DC00210
 Generated for : Breede River Project Date plotted : Jan 02 1992

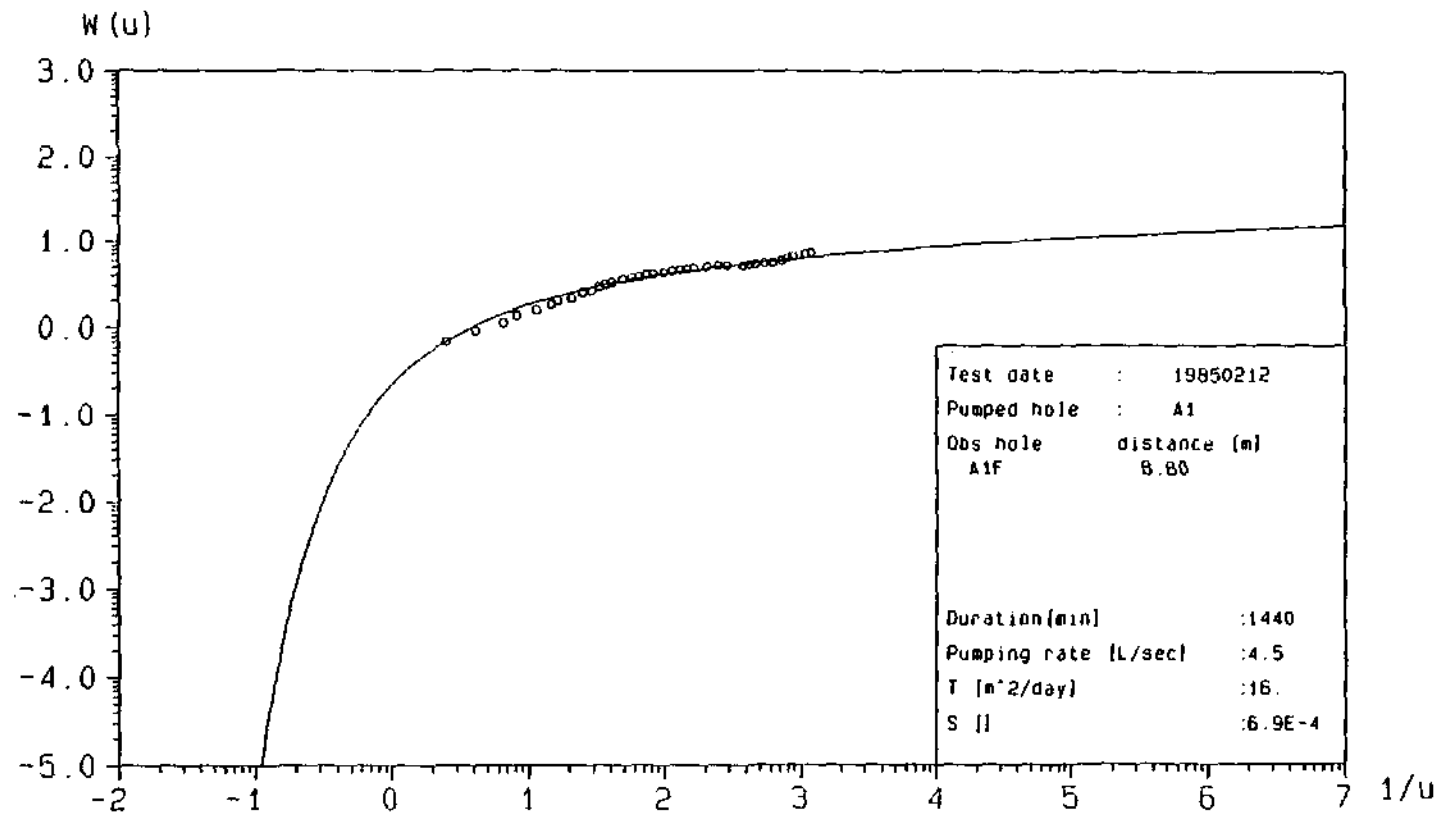

Test date : 19850212

Pumped hole : A1

Obs hole distance (m)
A1F 8.80

Duration (min) : 1440

Pumping rate (L/sec) : 4.5

T (m²/day) : 16.

S II : 6.9E-4

* HydroGraph - Theis pumping test analysis
Generated for : Breede River Project

* Site id : 33190C00210
Date plotted : Jan 02 1992

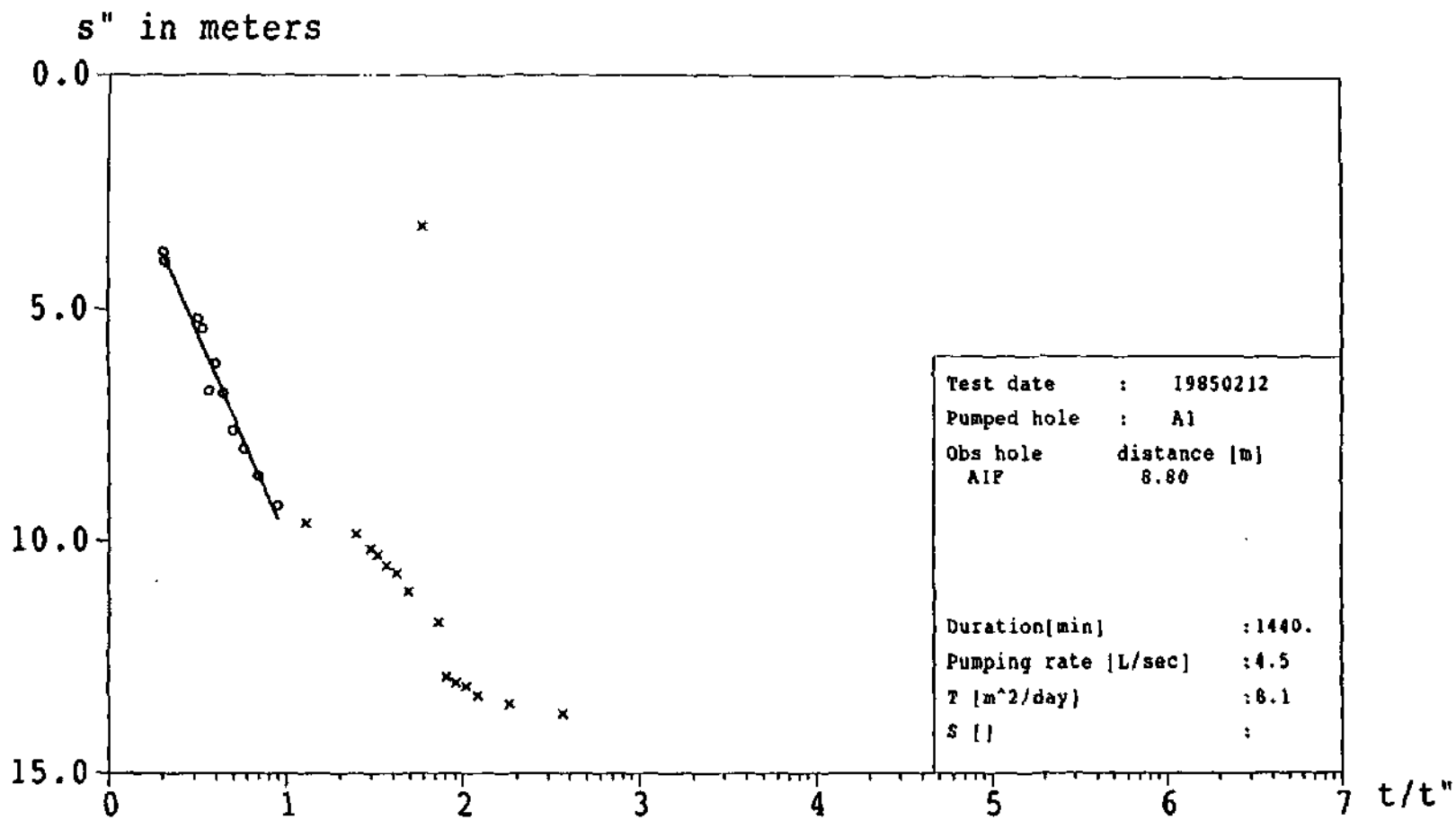

* HydroGraph - Theis recovery pumping test analysis * Site id :3319DC00210
 Generated for : Breede River Project Date plotted : Jan 02 1992

59
85

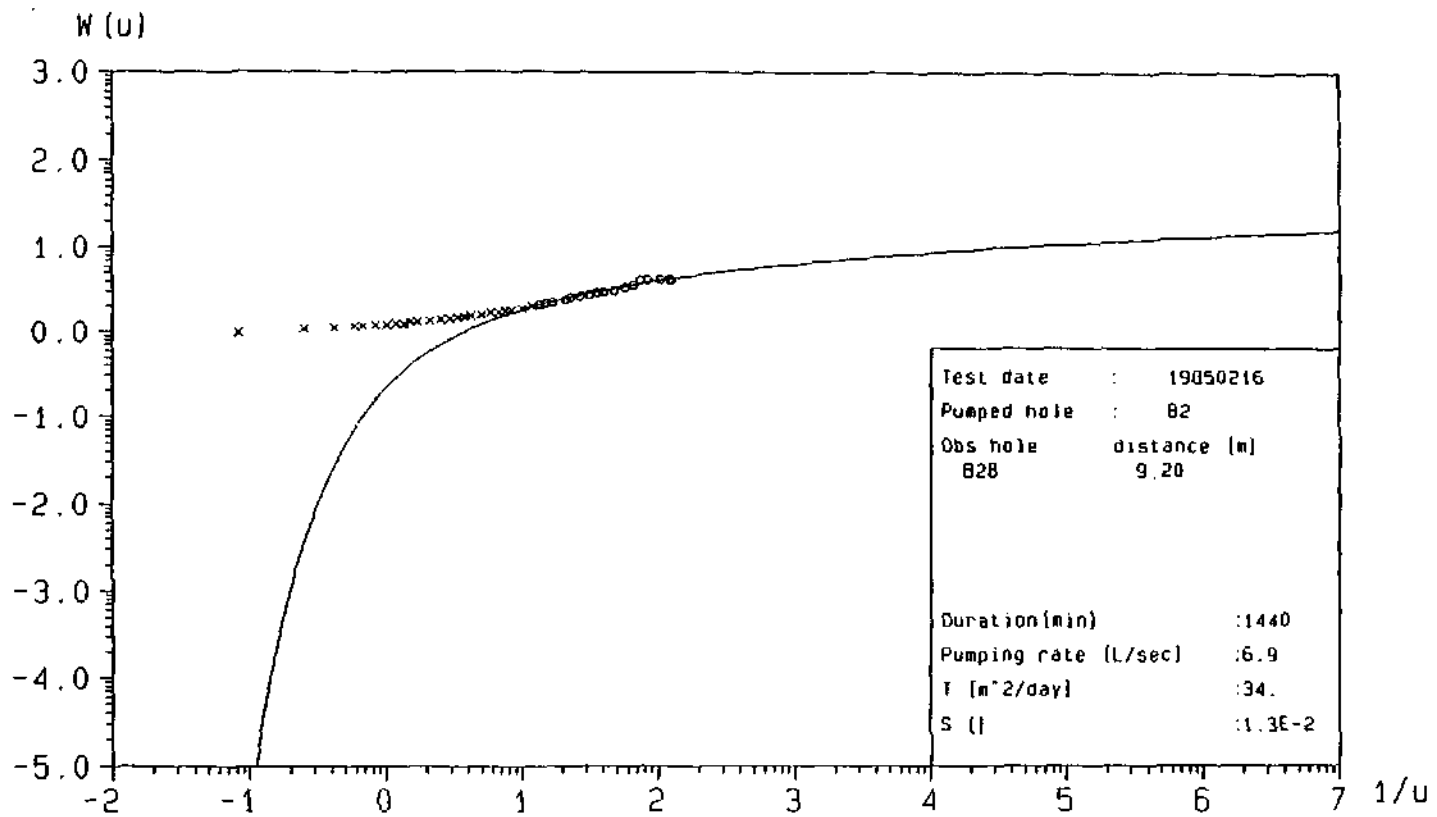

* HydroGraph - Theis pumping test analysis
Generated for : Breede River Project

* Site id : 33190000240
Date plotted : Jan 02 1992

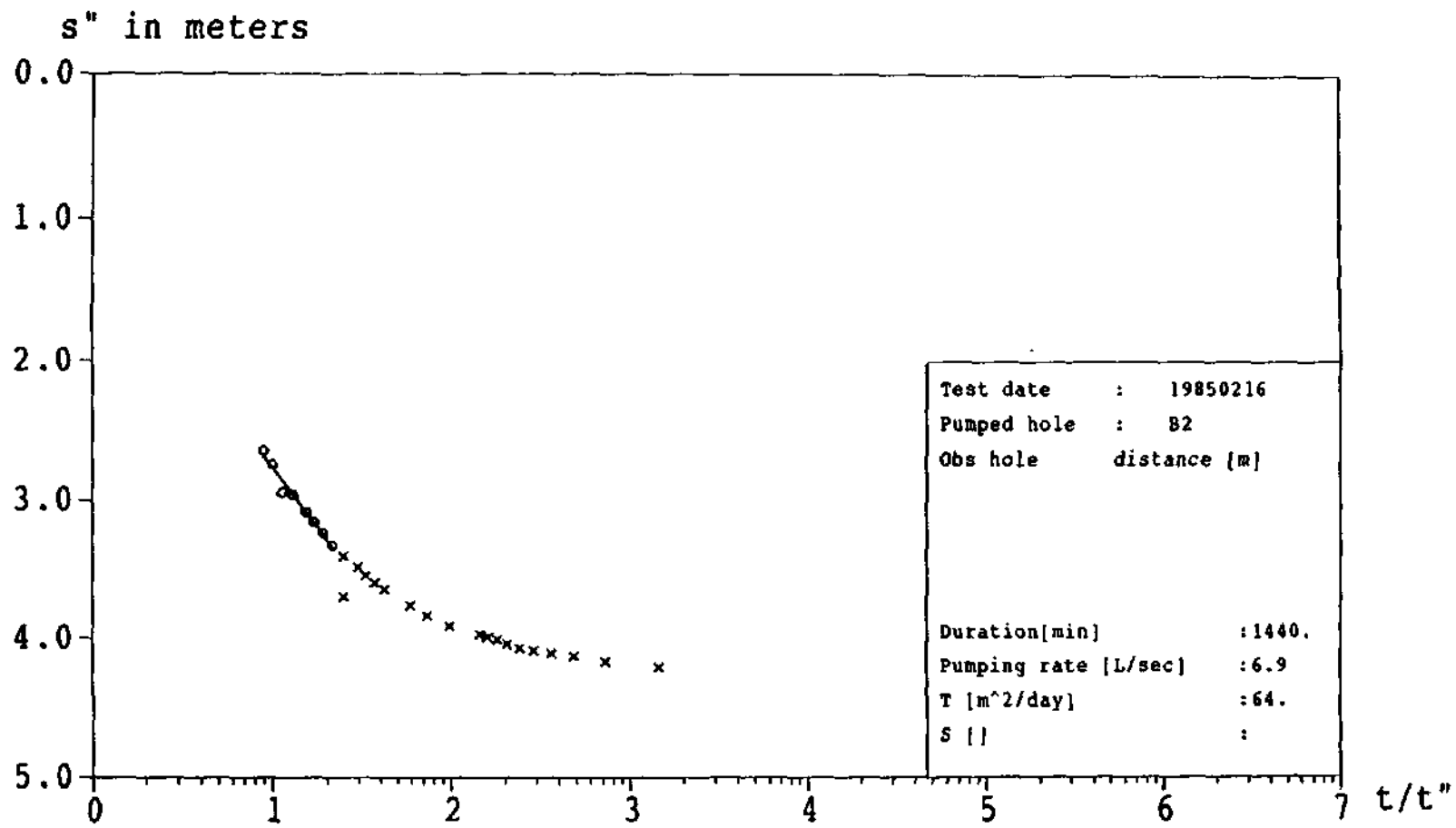

* HydroGraph - This recovery pumping test analysis * Site id : 3319DC00240
 Generated for : Breede River Project Date plotted : Jan 02 1992

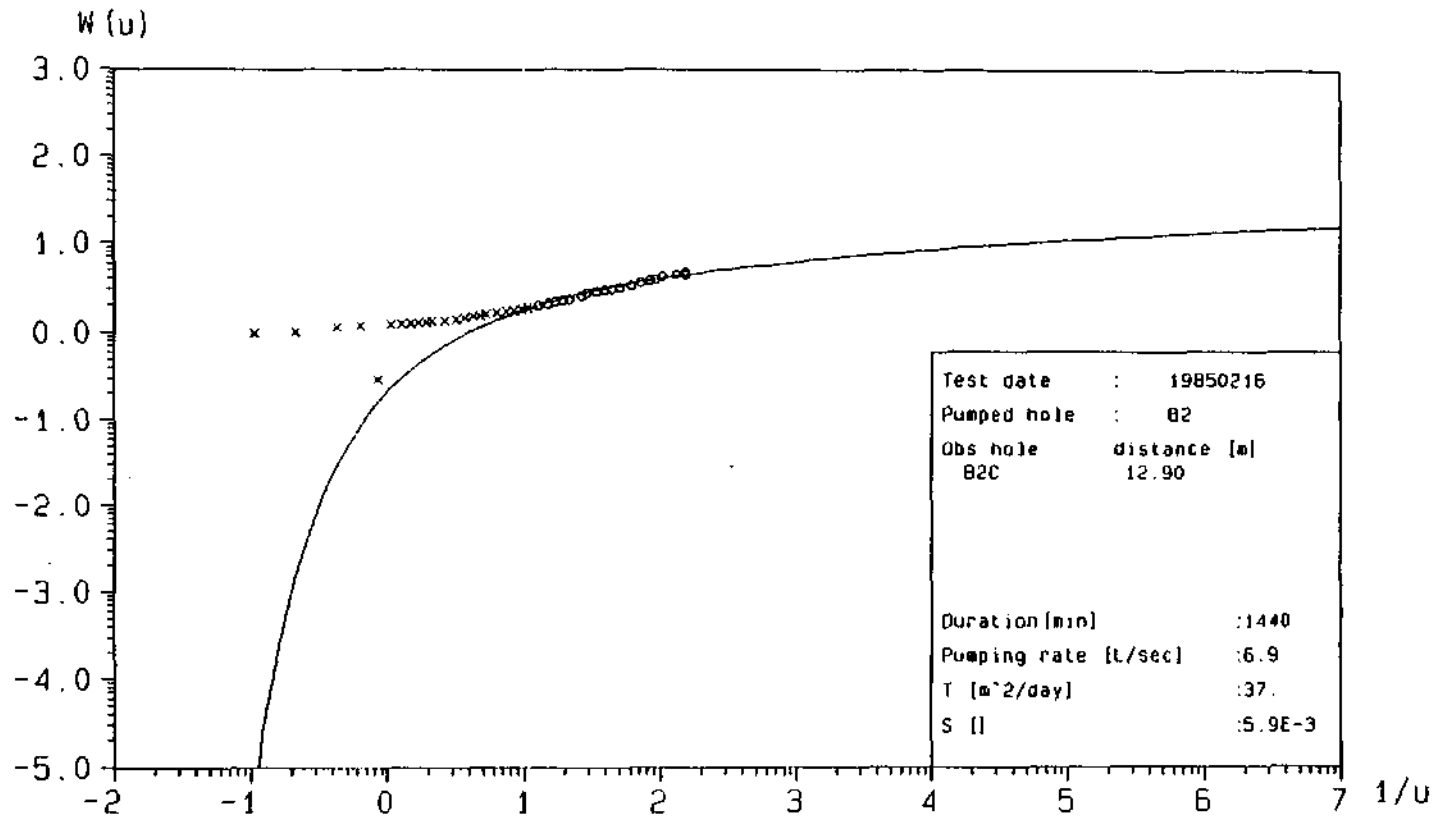

* HydroGraph - Theis pumping test analysis
Generated for : Breede River Project

* Site id : 3319DC00240
Date plotted : Jan 02 1992

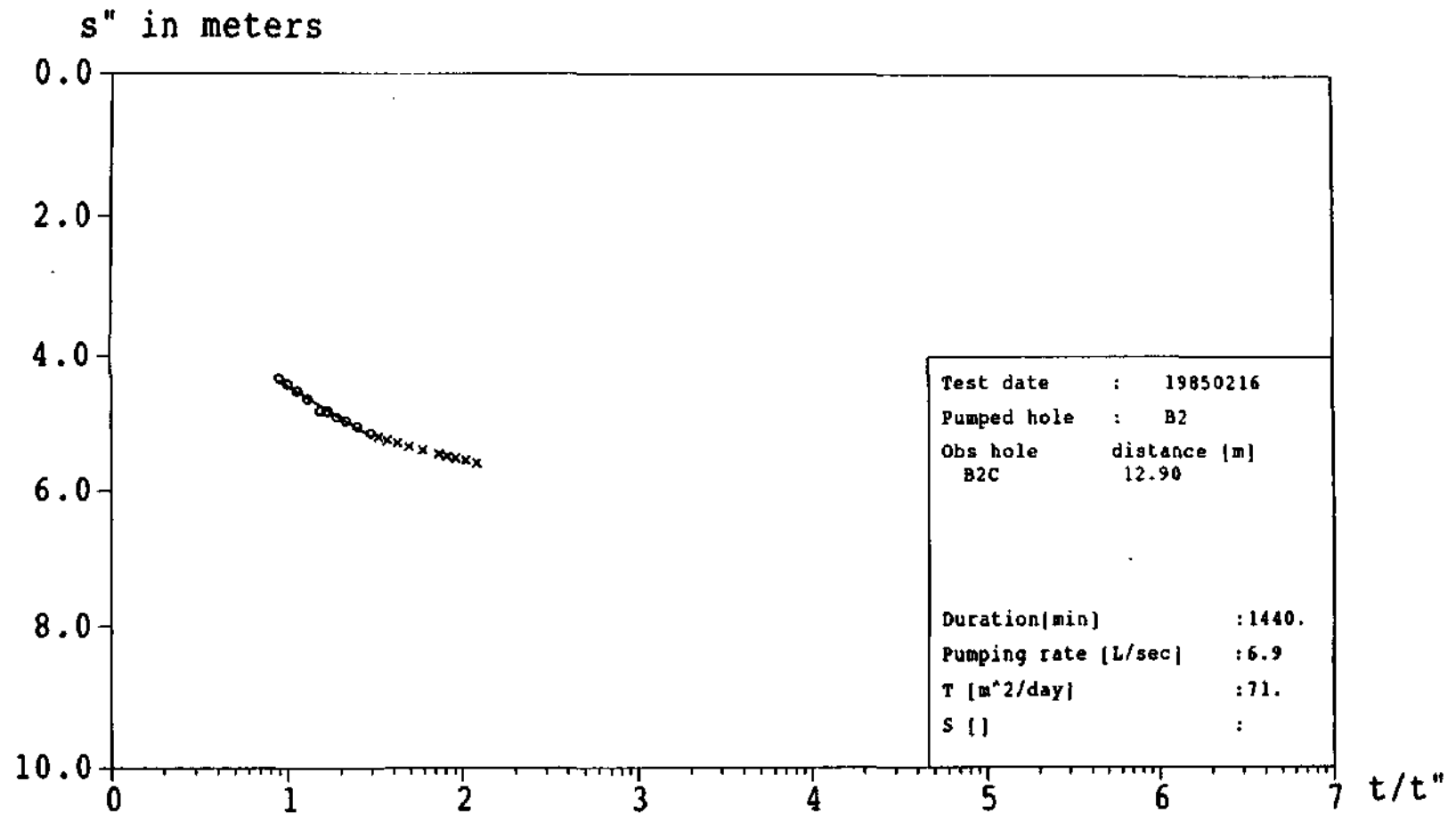

Test date	:	19850216
Pumped hole	:	B2
Obs hole	:	distance [m]
B2C	:	12.90
Duration[min]	:	1440.
Pumping rate [L/sec]	:	6.9
T [m^2/day]	:	71.
S []	:	

* HydroGraph - Theis recovery pumping test analysis * Site id :3319DC00240
 Generated for : Breede River Project Date plotted : Jan 02 1992

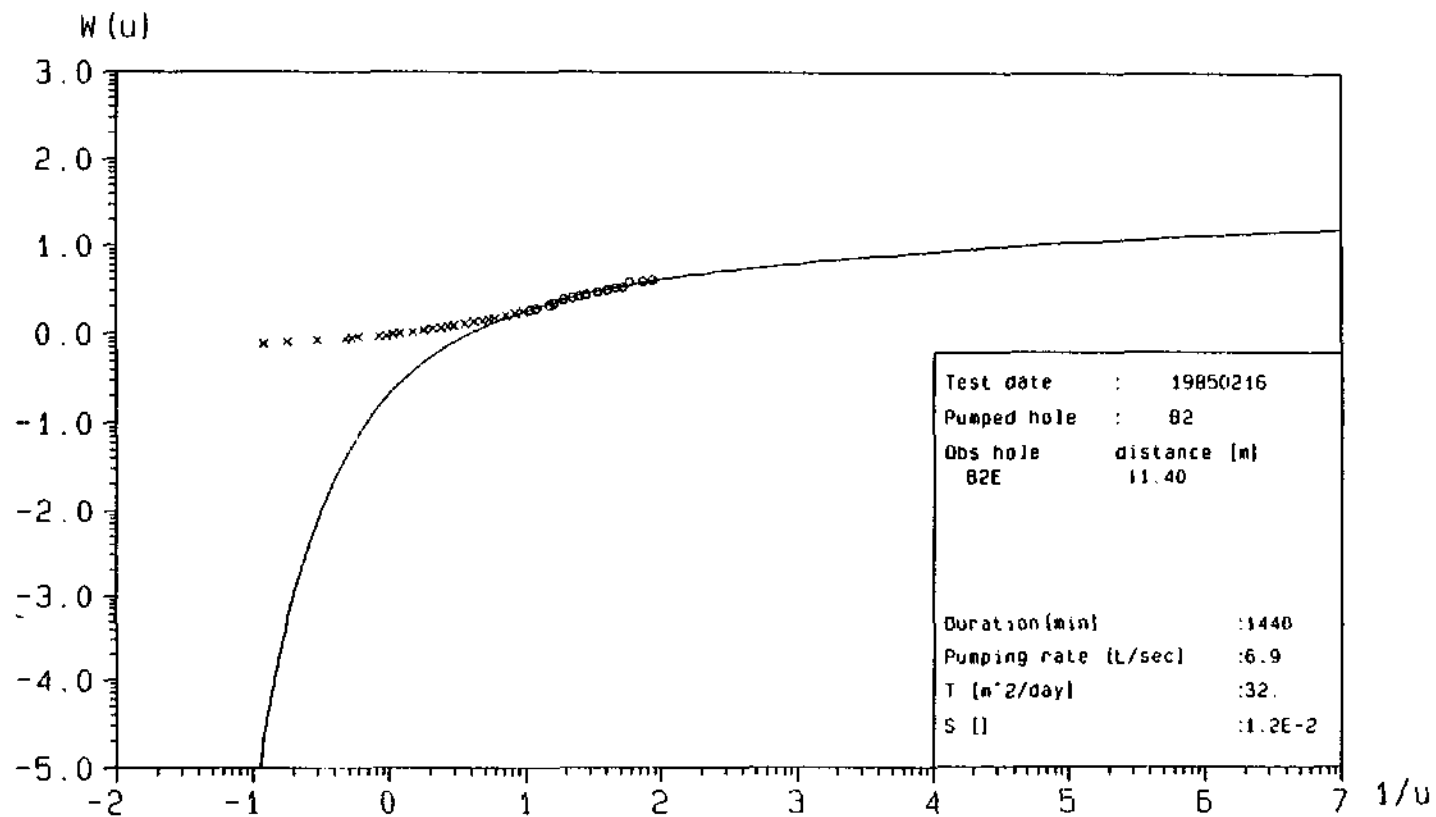

* HydroGraph - Theis pumping test analysis
 Generated for : Breede River Project

* Site id : 3319DC00240
 Date plotted : Jan 02 1992

64

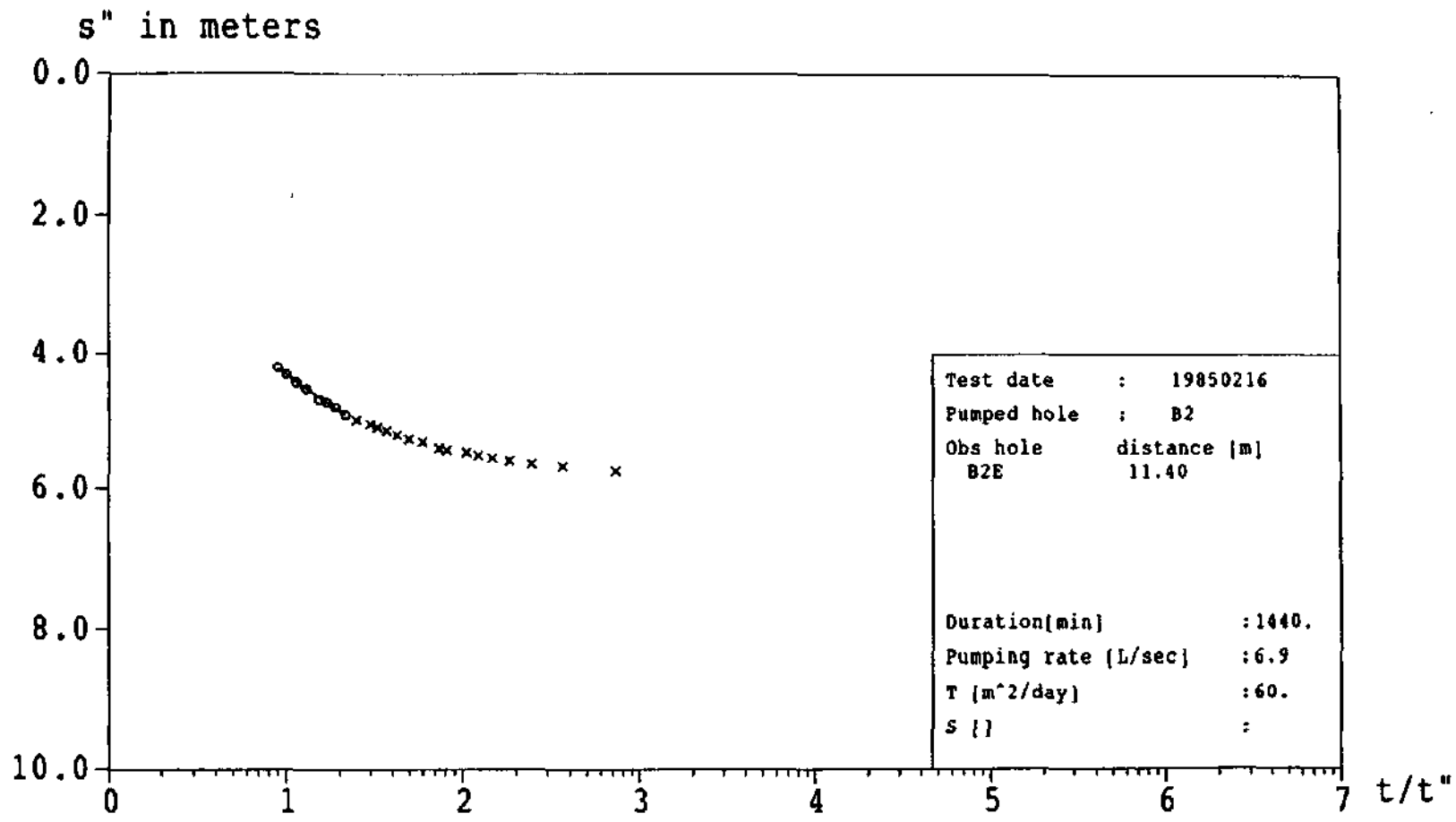

Test date	: 19850216
Pumped hole	: B2
Obs hole	distance [m]
B2E	11.40
Duration[<i>min</i>]	: 1440.
Pumping rate [L/sec]	: 6.9
T [<i>m</i> ² /day]	: 60.
S {}	:

* HydroGraph - This recovery pumping test analysis * Site id :3319DC00240
 Generated for : Breede River Project Date plotted : Jan 02 1992

65

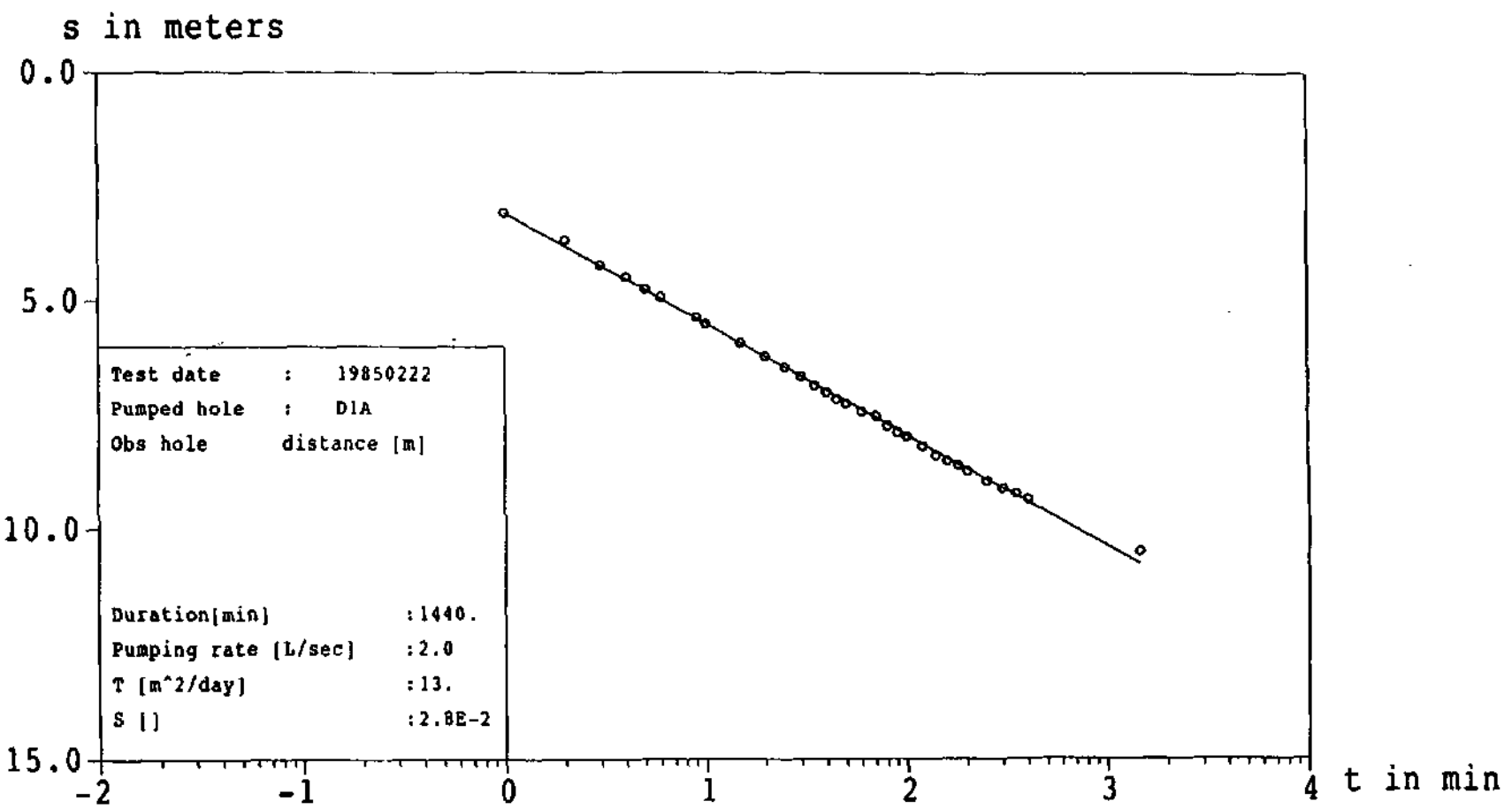

* HydroGraph - Cooper Jacob pumping test analysis
Generated for : Breede River Project

* Site id : 3319DC00281
Date plotted : Jan 02 1992

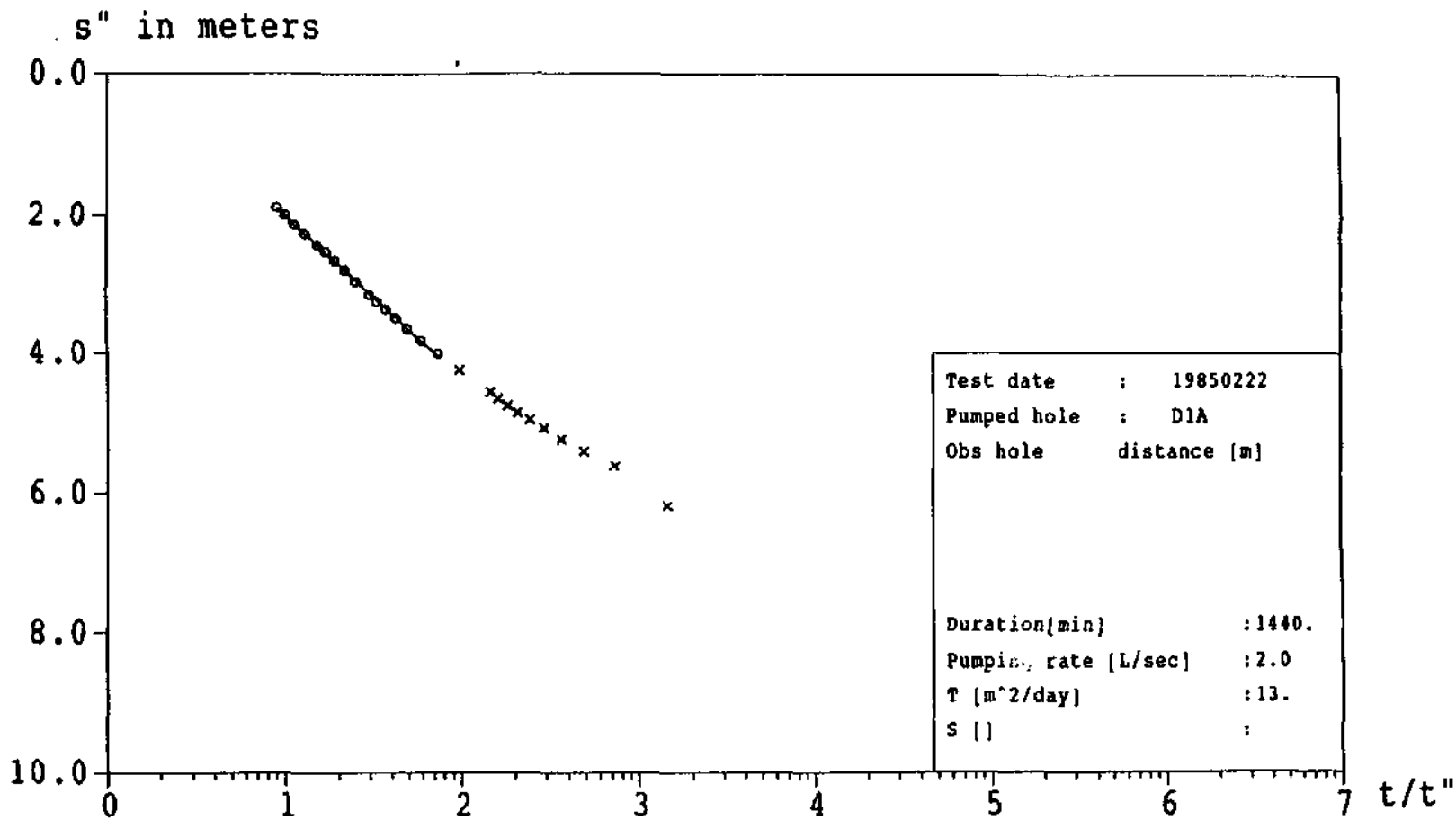

Test date	:	19850222
Pumped hole	:	D1A
Obs hole	:	distance [m]
Duration[<i>min</i>]	:	1440.
Pumping rate [L/sec]	:	2.0
T [<i>m</i> ² /day]	:	13.
S []	:	

* HydroGraph - This recovery pumping test analysis * Site id :3319DC00281
 Generated for : Breede River Project Date plotted : Jan 02 1992

s" in meters

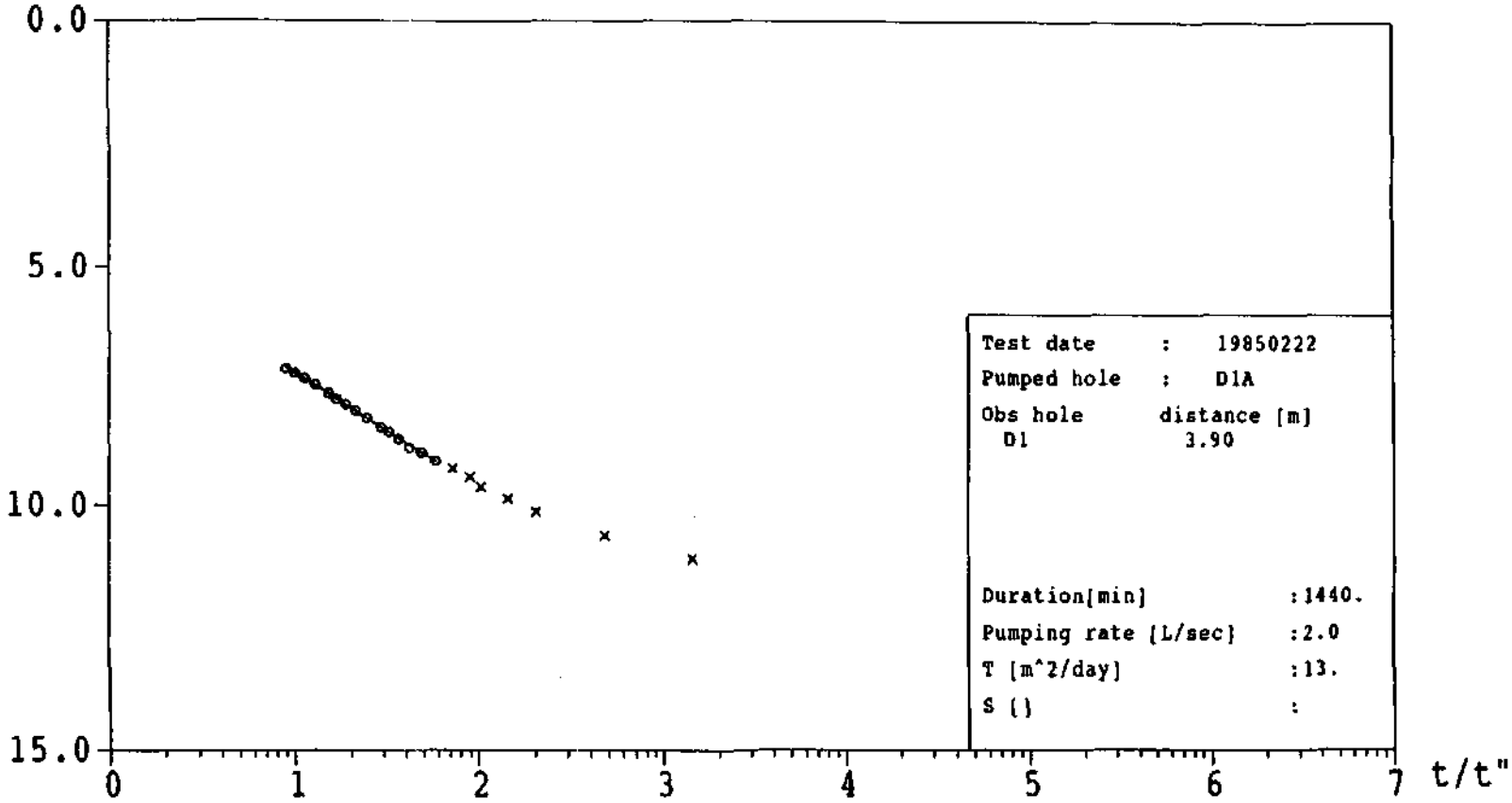

Test date	: 19850222
Pumped hole	: DIA
Obs hole distance [m]	
01	3.90
Duration[min]	: 1440.
Pumping rate [L/sec]	: 2.0
T [m ² /day]	: 13.
S (%)	:

67

* HydroGraph - Theis recovery pumping test analysis * Site id : 3319DC00281
Generated for : Breede River Project Date plotted : Jan 02 1992

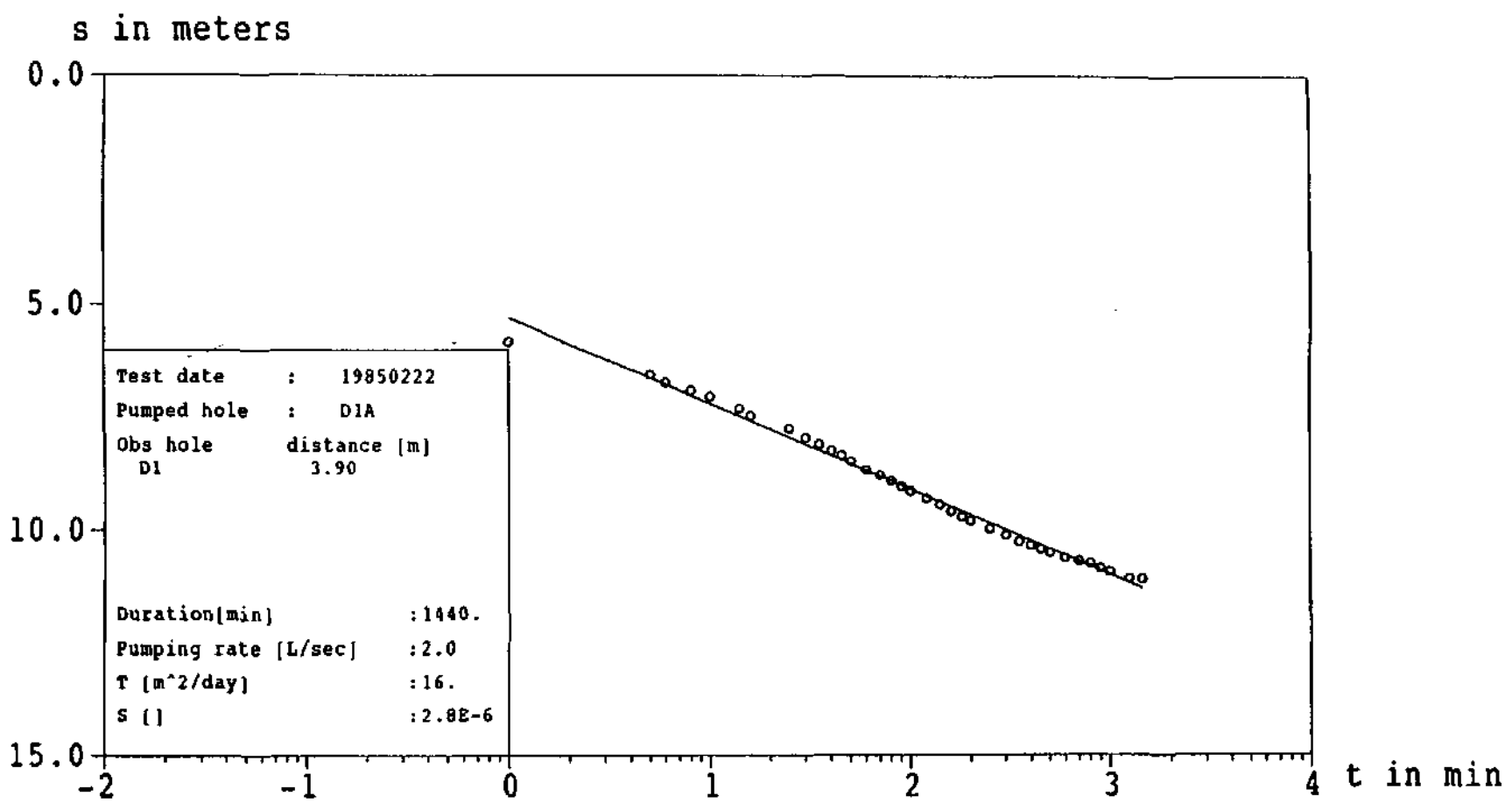

* HydroGraph - Cooper Jacob pumping test analysis * Site id :3319DC00281
Generated for : Breede River Project Date plotted : Jan 02 1992

69

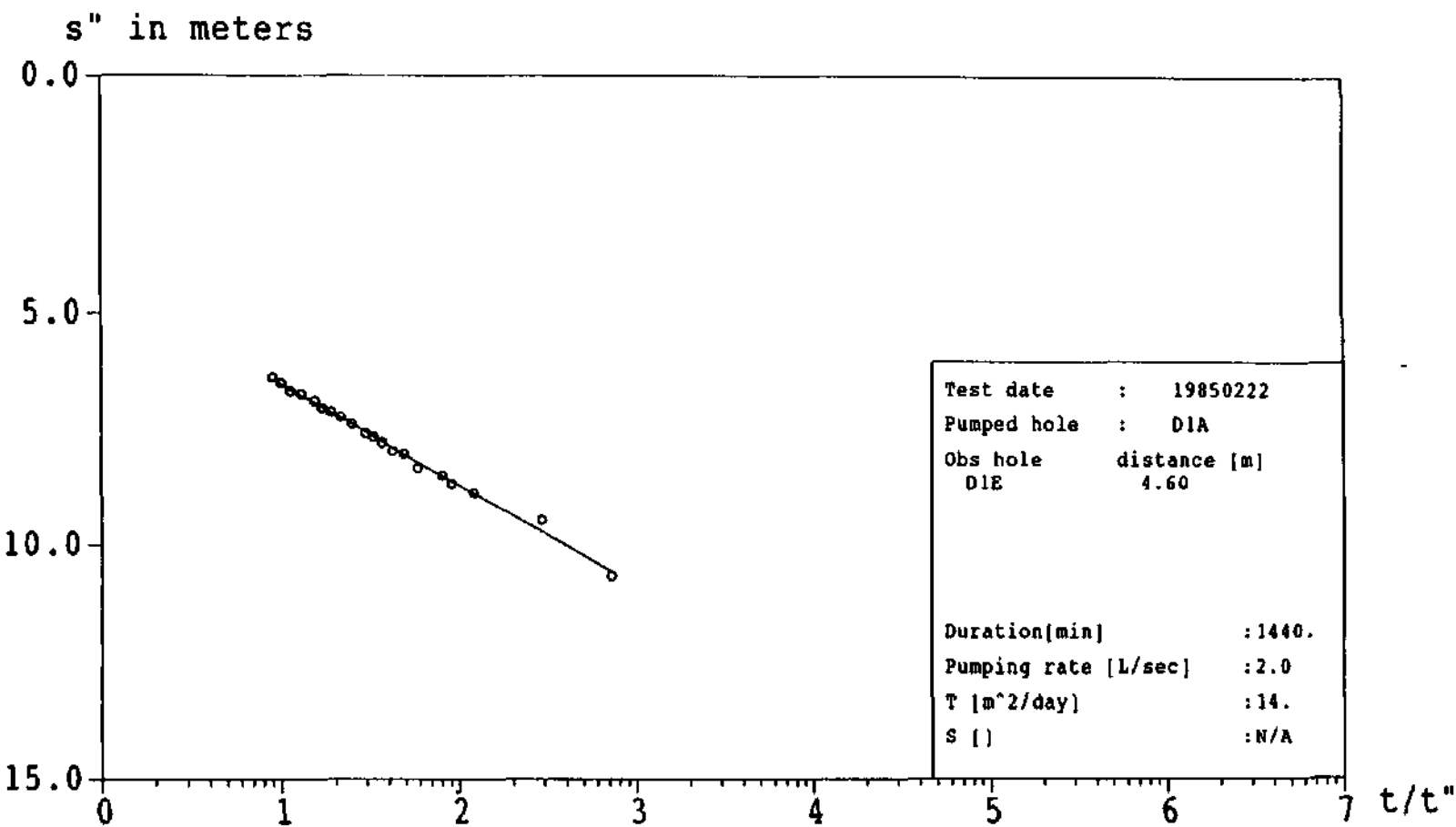

* HydroGraph - Theis recovery pumping test analysis * Site id :3319DC00281
 Generated for : Breede River Project Date plotted : Jan 02 1992

70

s in meters

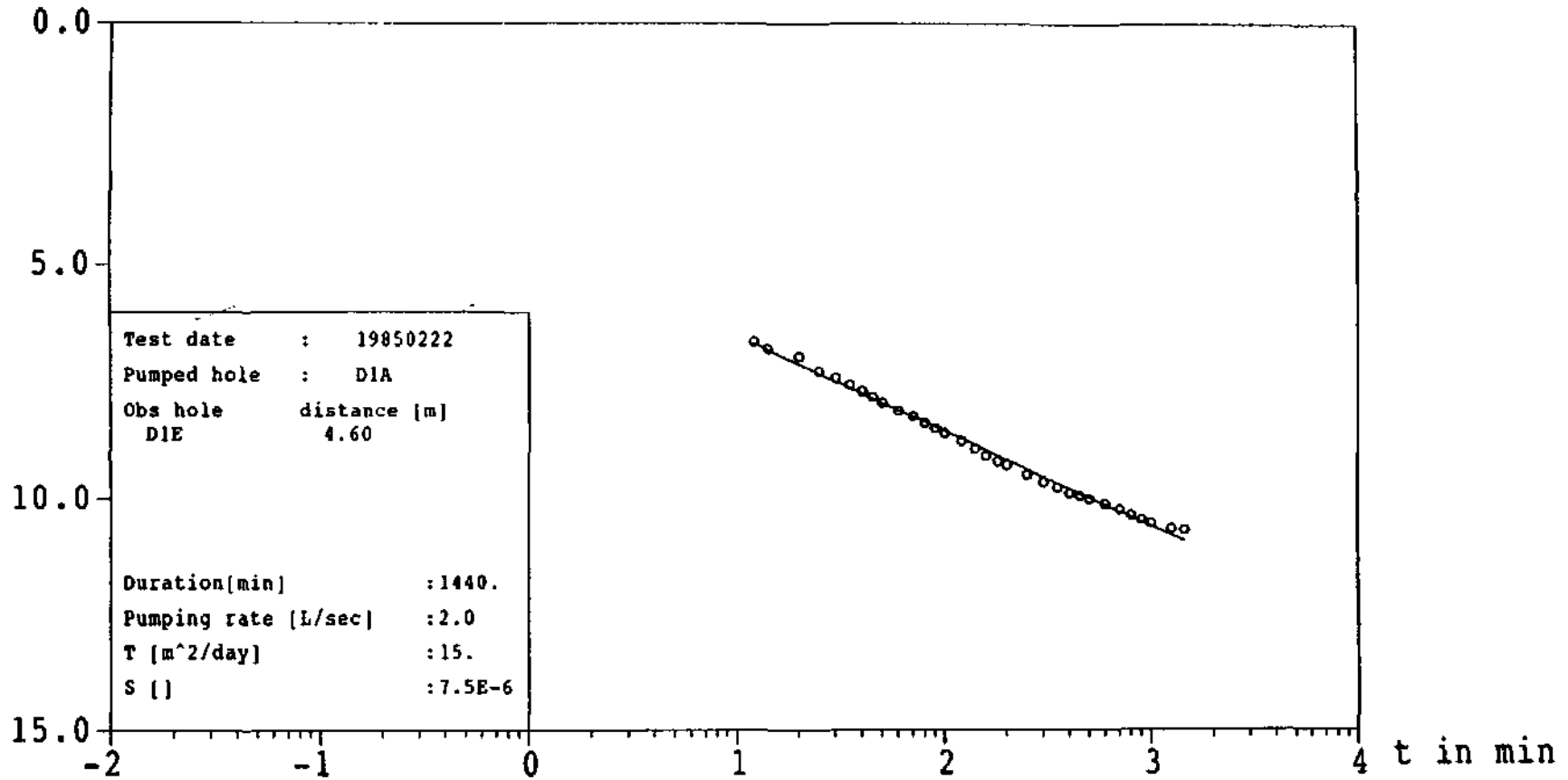

* HydroGraph - Cooper Jacob pumping test analysis
 Generated for : Breede River Project

* Site id :3319DC00281
 Date plotted : Jan 02 1992

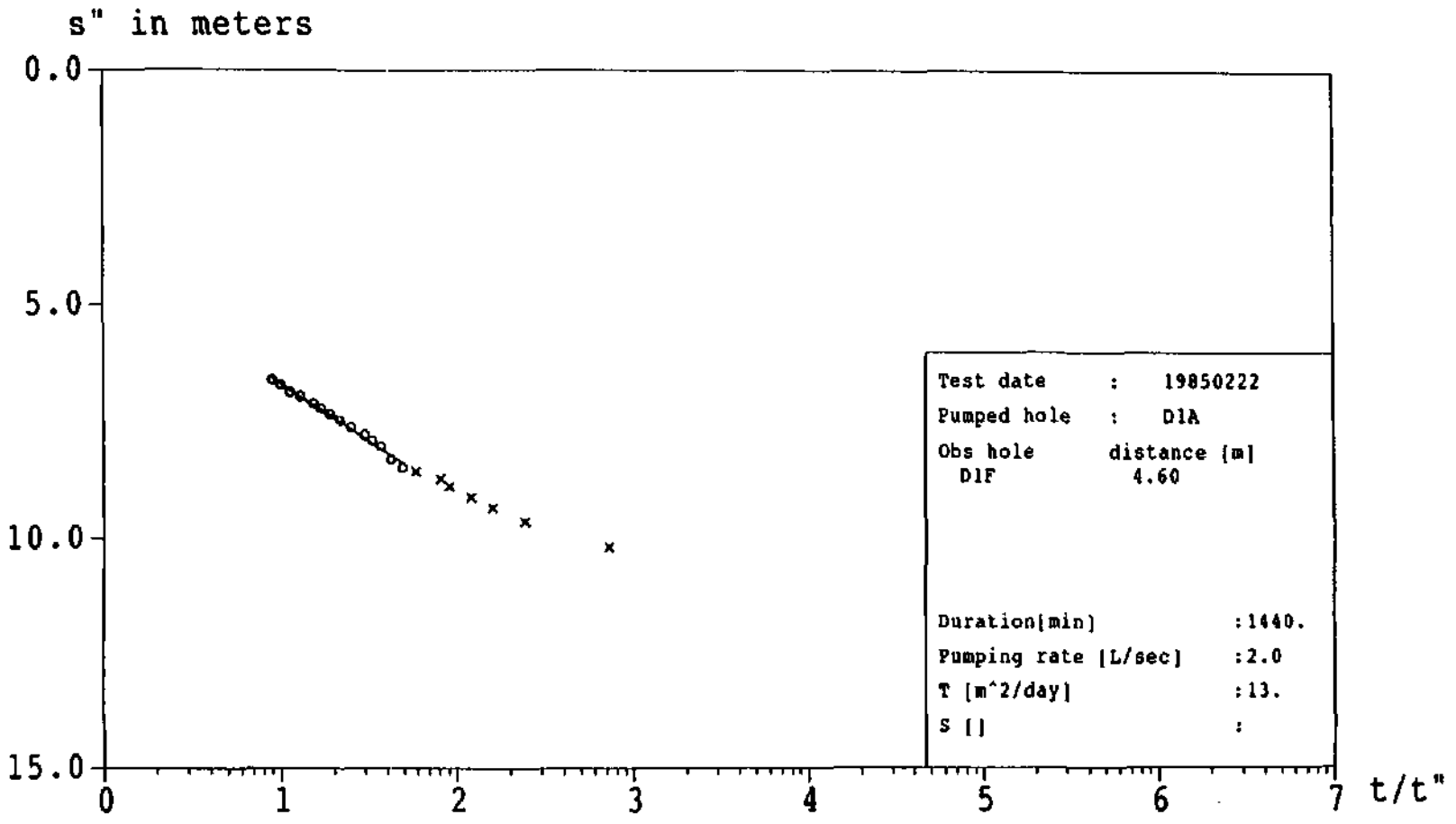

* HydroGraph - Theis recovery pumping test analysis * Site id :3319DC00281
 Generated for : Breede River Project Date plotted : Jan 02 1992

72

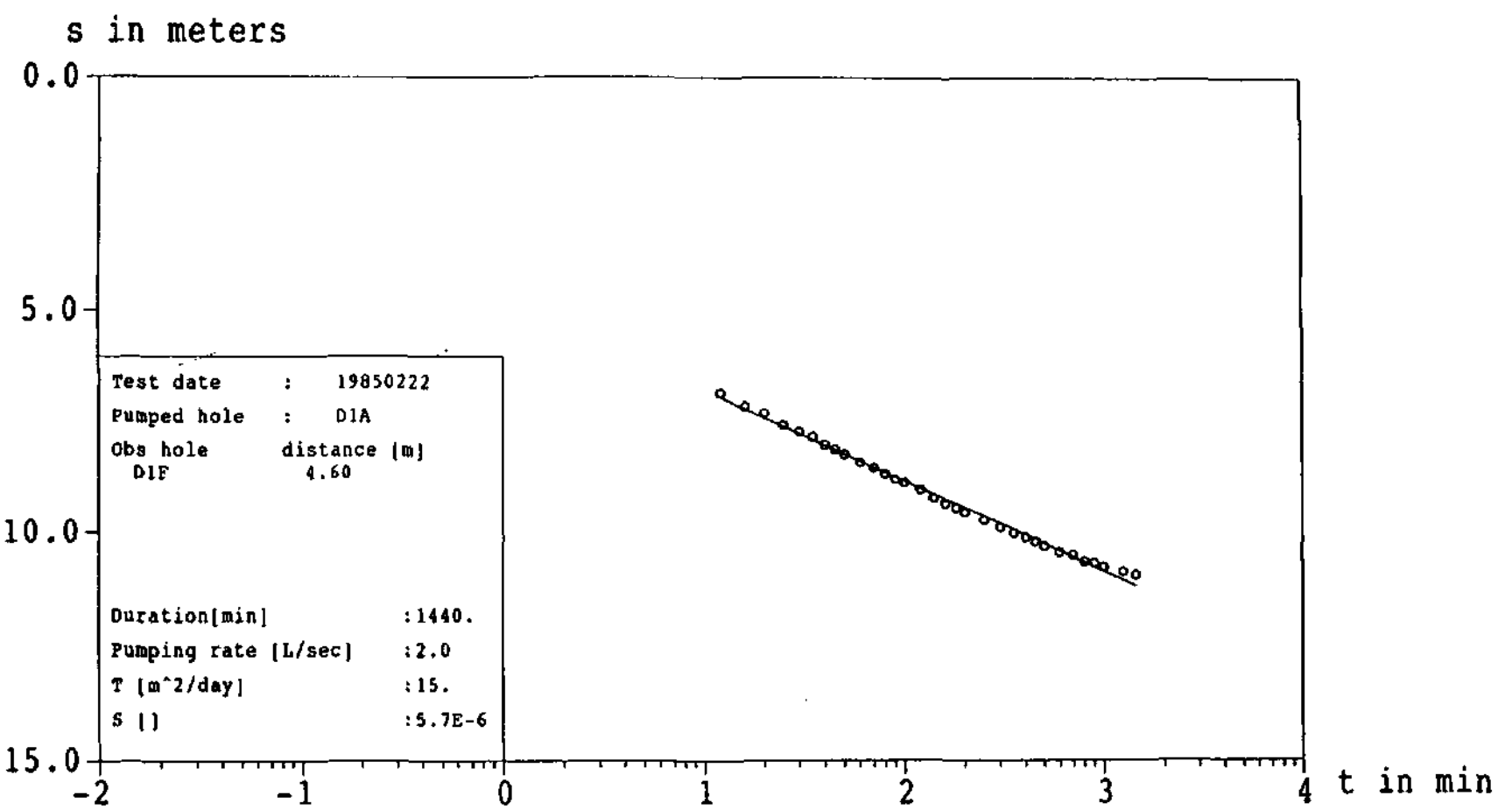

* HydroGraph - Cooper Jacob pumping test analysis * Site id :3319DC00281
 Generated for : Breede River Project Date plotted : Jan 02 1992

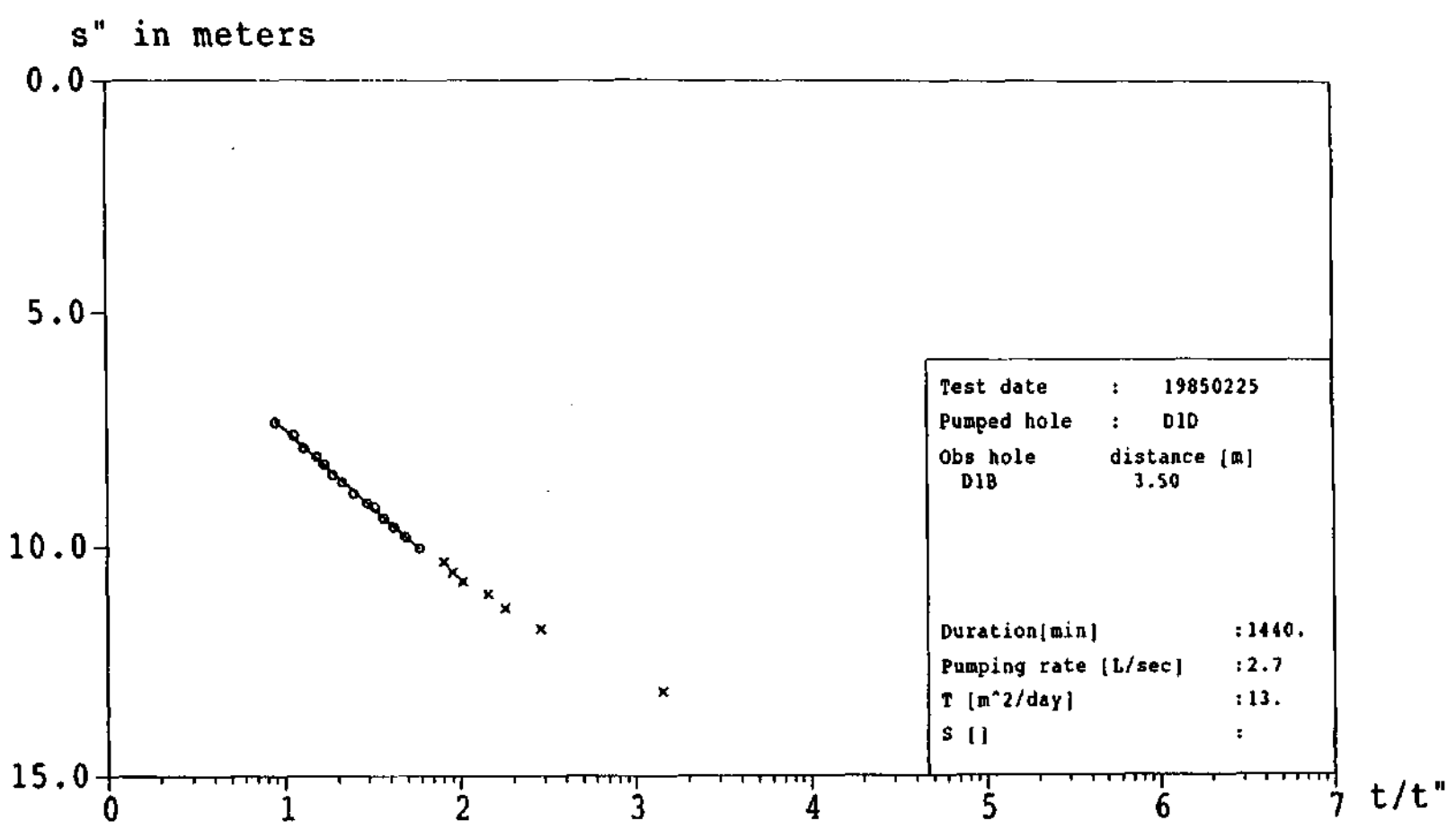

* HydroGraph - Theis recovery pumping test analysis * Site id :3319DC00284
 Generated for : Breede River Project Date plotted : Jan 02 1992

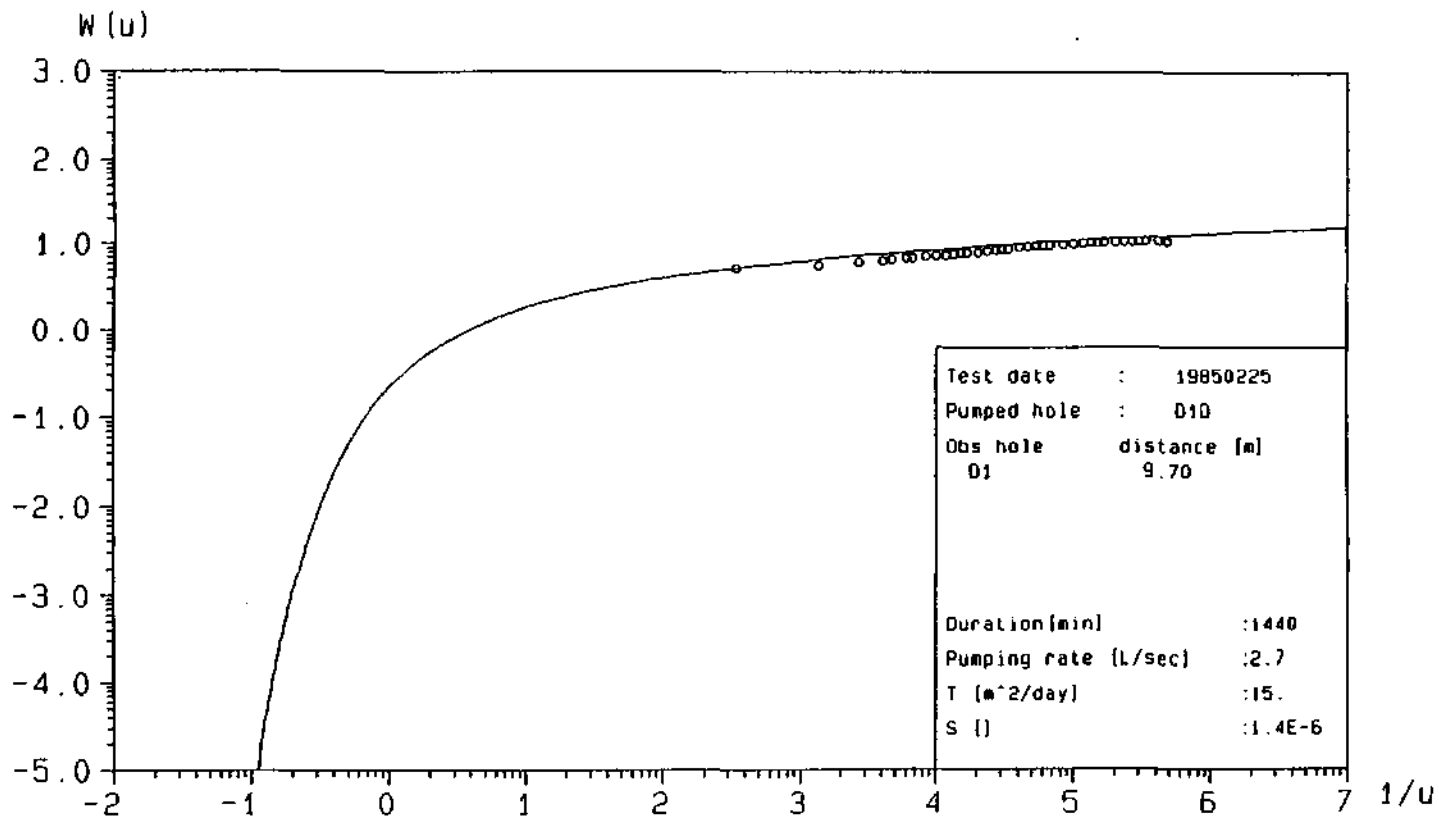

Test date	: 19850225
Pumped hole	: 010
Obs hole	distance [m]
01	9.70
Duration[min]	:1440
Pumping rate (L/sec)	:2.7
T (m ² /day)	:15.
S [l]	:1.4E-6

* HydroGraph - This pumping test analysis
Generated for : Breede River Project

* Site id : 3319DC00284
Date plotted : Jan 02 1992

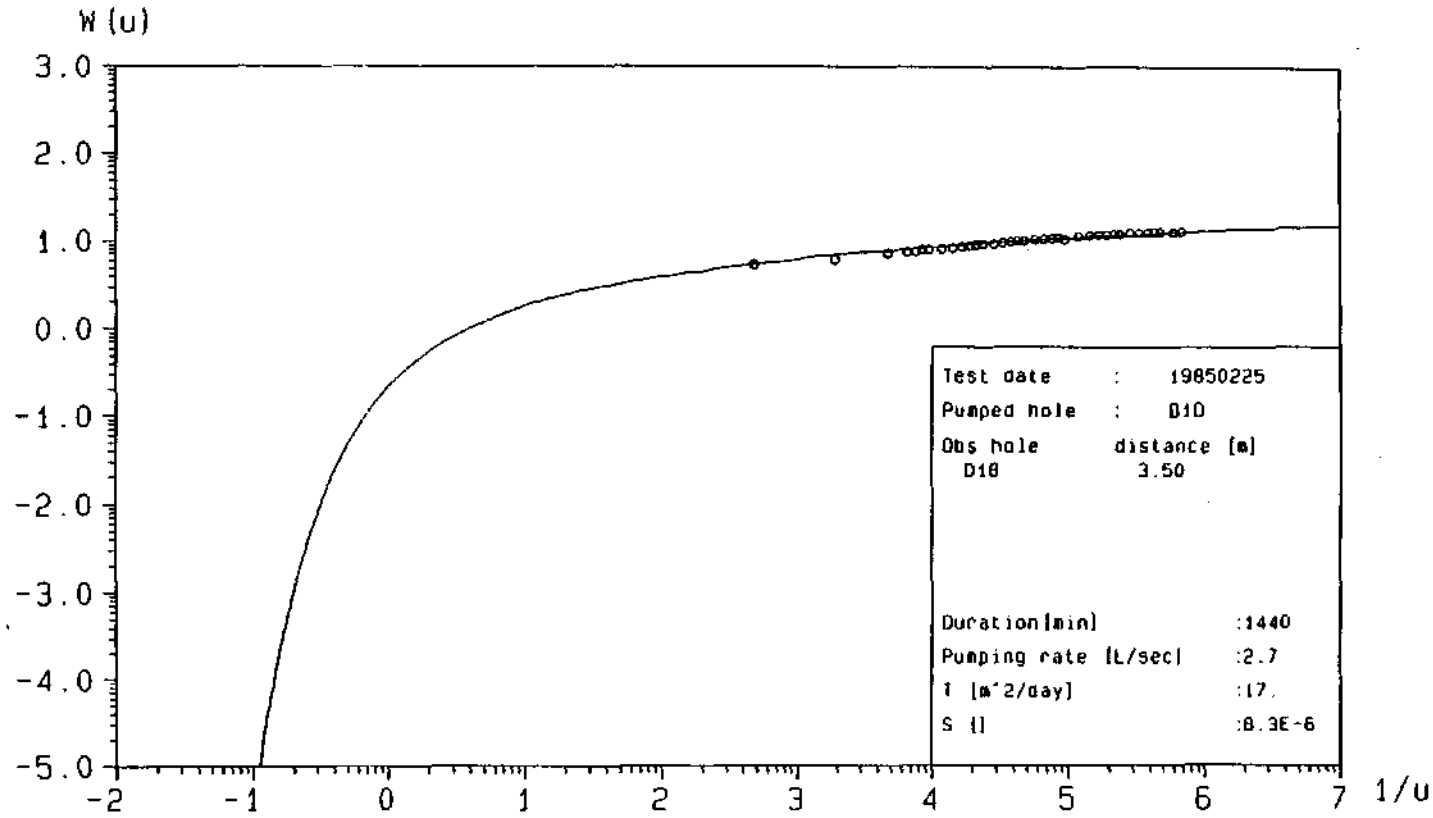

* HydroGraph - Theis pumping test analysis
Generated for : Breede River Project

* Site id : 3319DC00284
Date plotted : Jan 02 1992

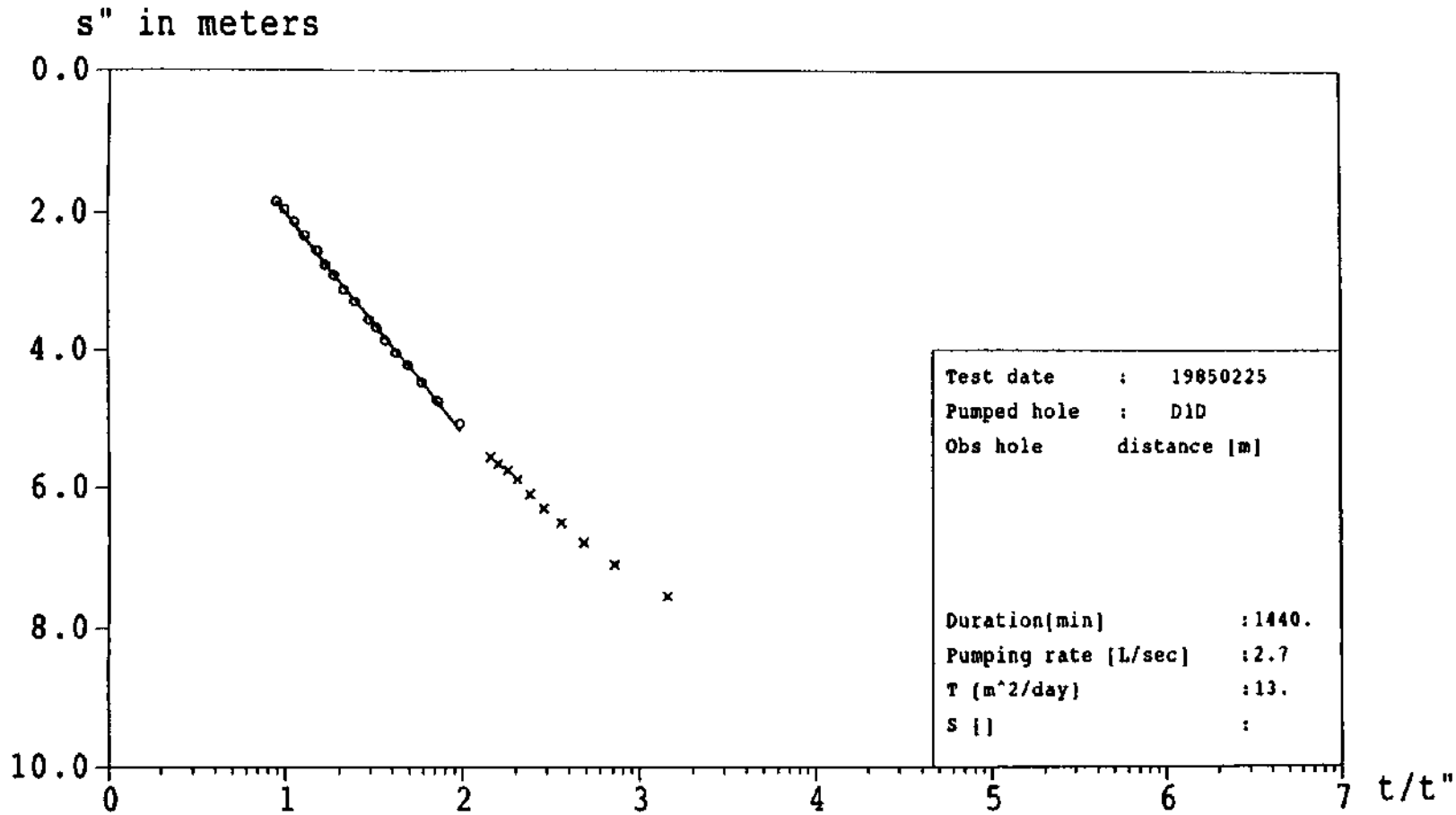

* HydroGraph - Theis recovery pumping test analysis * Site id : 3319DC00284
 Generated for : Breede River Project Date plotted : Jan 02 1992

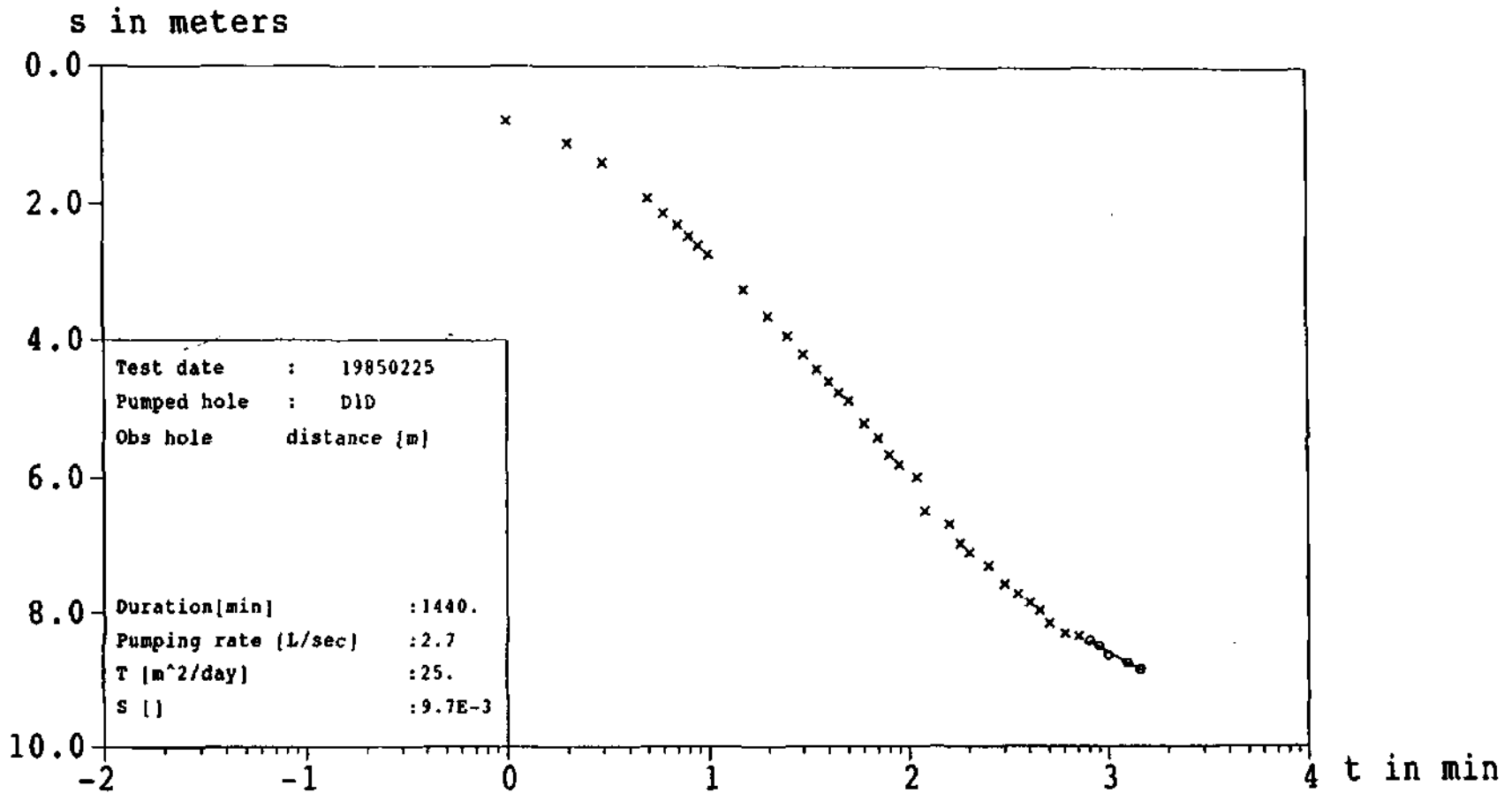

* HydroGraph - Cooper Jacob pumping test analysis
 Generated for : Breede River Project

* Site id : 3319DC00284
 Date plotted : Jan 02 1992

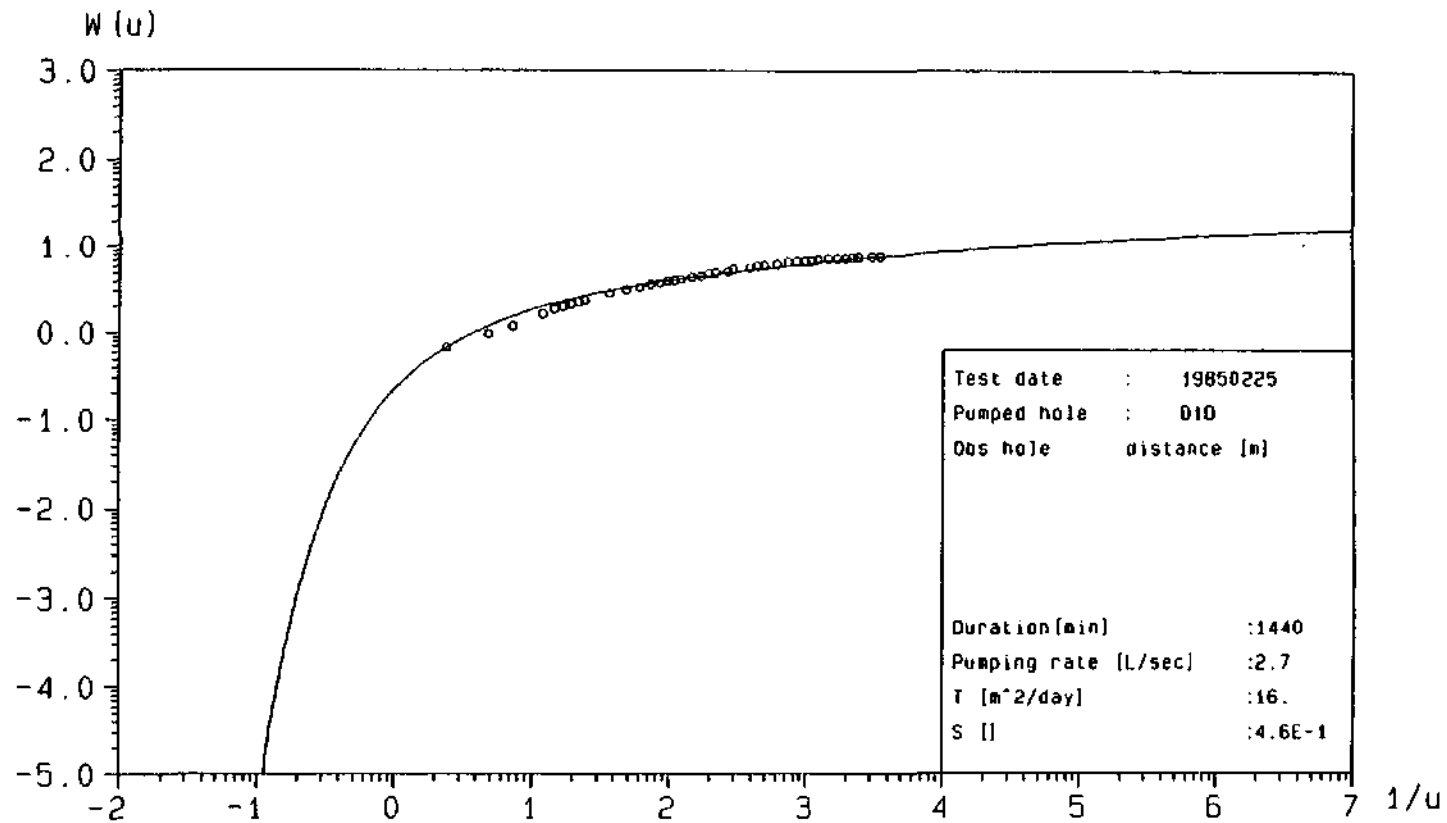

* HydroGraph - Theis pumping test analysis
Generated for : Breede River Project

* Site id : 3319DC00284
Date plotted : Jan 02 1992

79

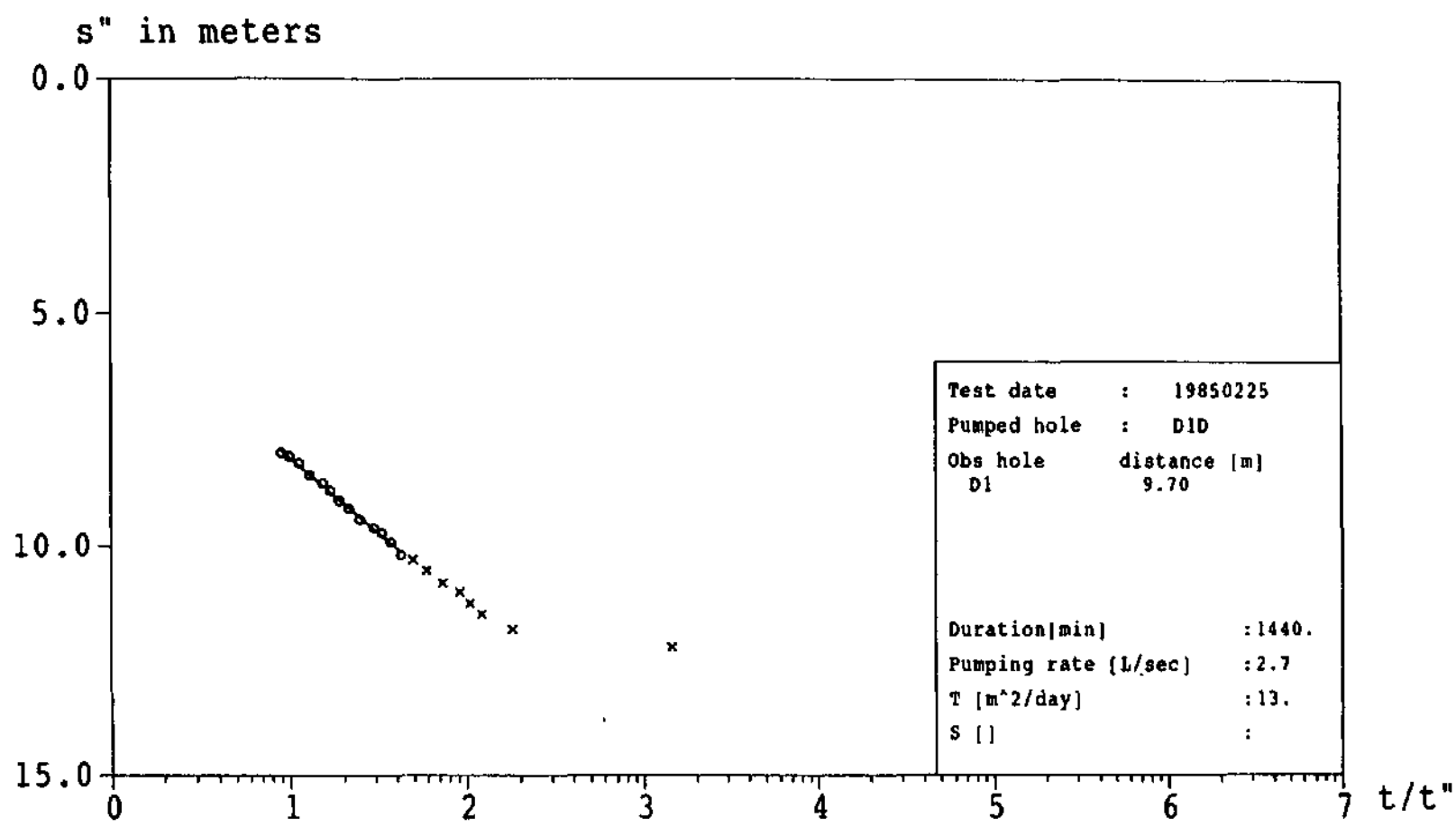

* HydroGraph - This recovery pumping test analysis * Site id : 3319DC00284
 Generated for : Breede River Project Date plotted : Jan 02 1992

Appendix 4

Exploration boreholes:
EC- and water-level graphs

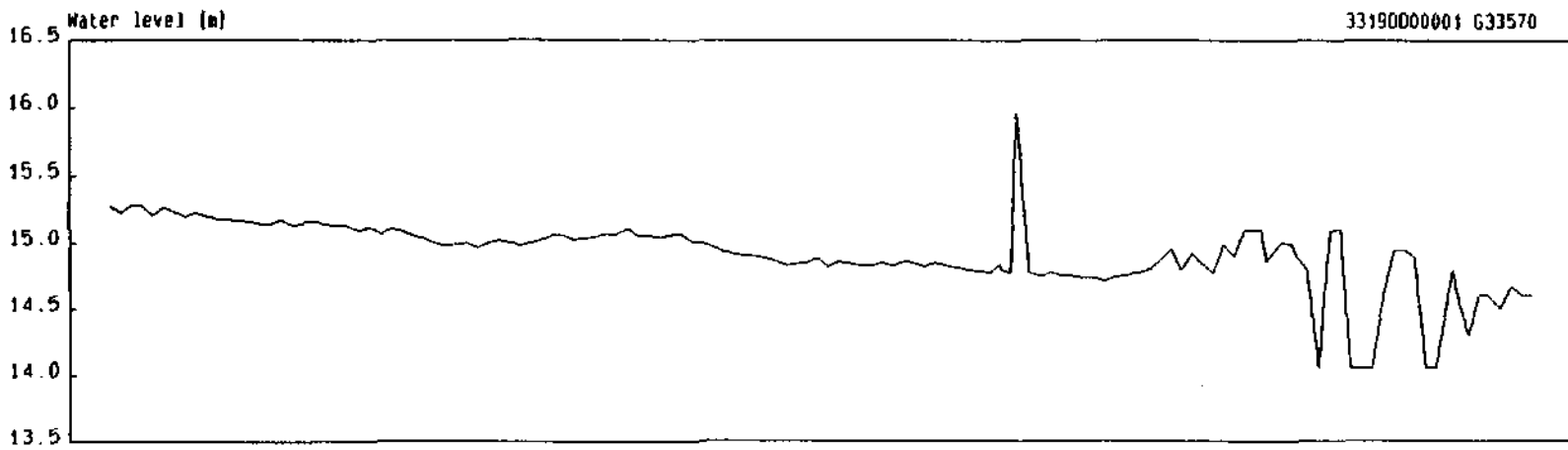
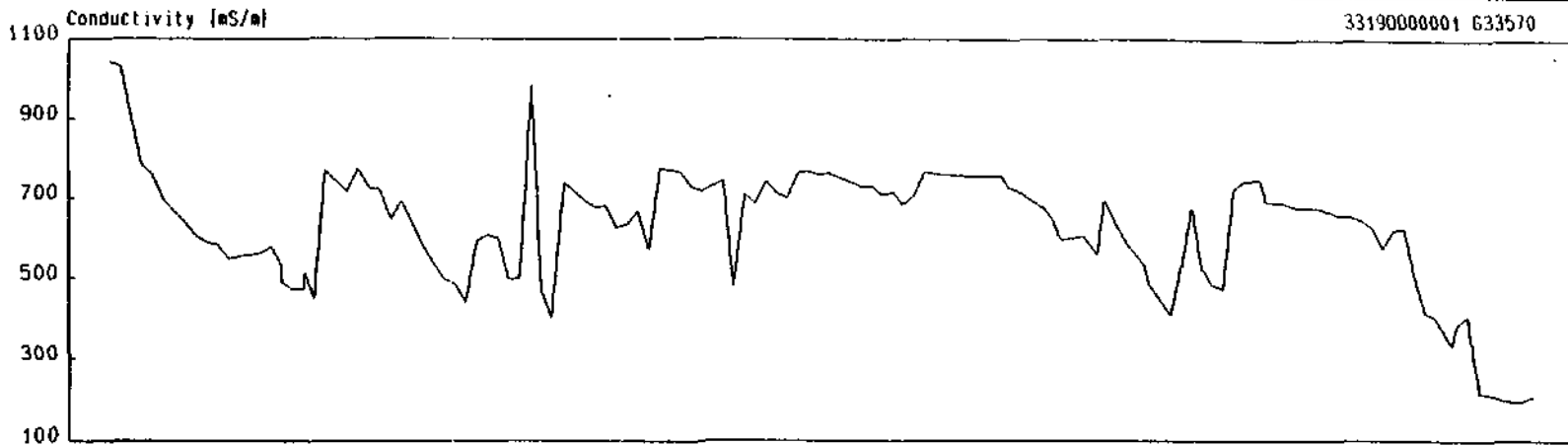

OCT	NOV	DEC	JAN	FEB	MAR	APR	MAY	JUN	JUL	AUG	SEP	OCT	NOV	DEC	JAN	FEB	MAR	APR	MAY	JUN	JUL	AUG	SEP	OCT	NOV	DEC	JAN	FEB	MAR	APR		
	1988																															

* HydroGraph * Time dependent graph * Date plotted: Oct 31 1991
 Generated for : Breede River Project

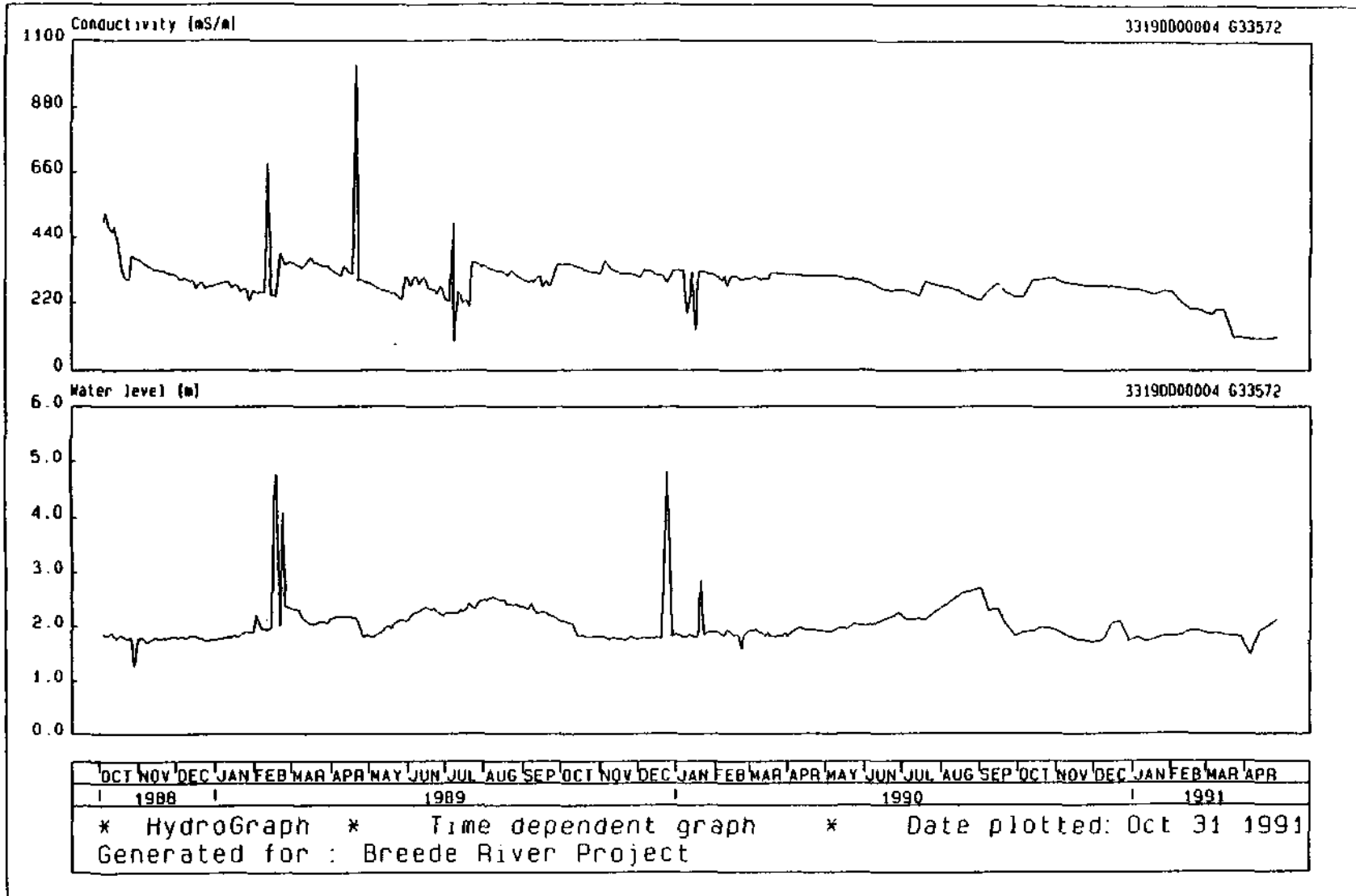

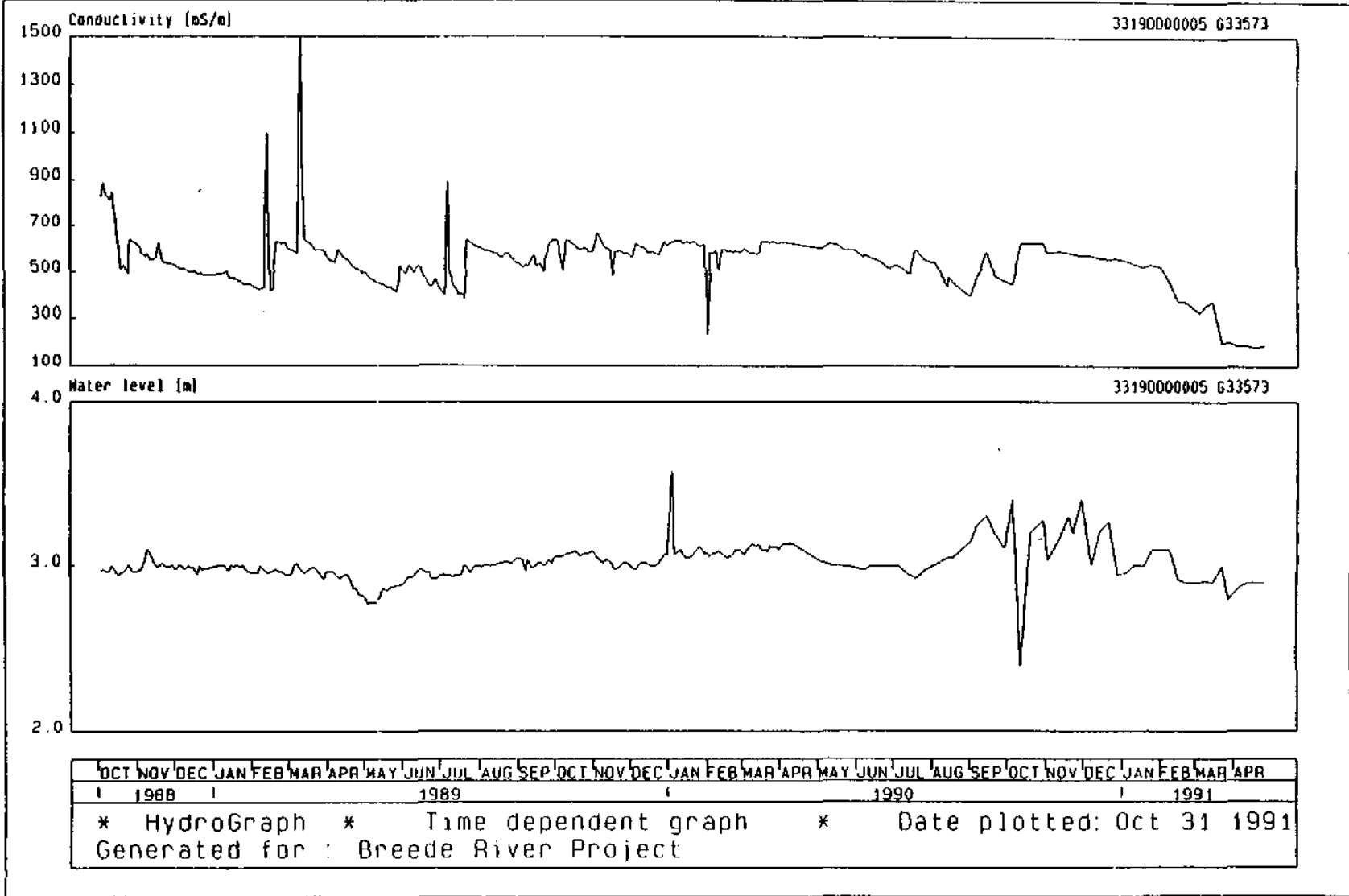

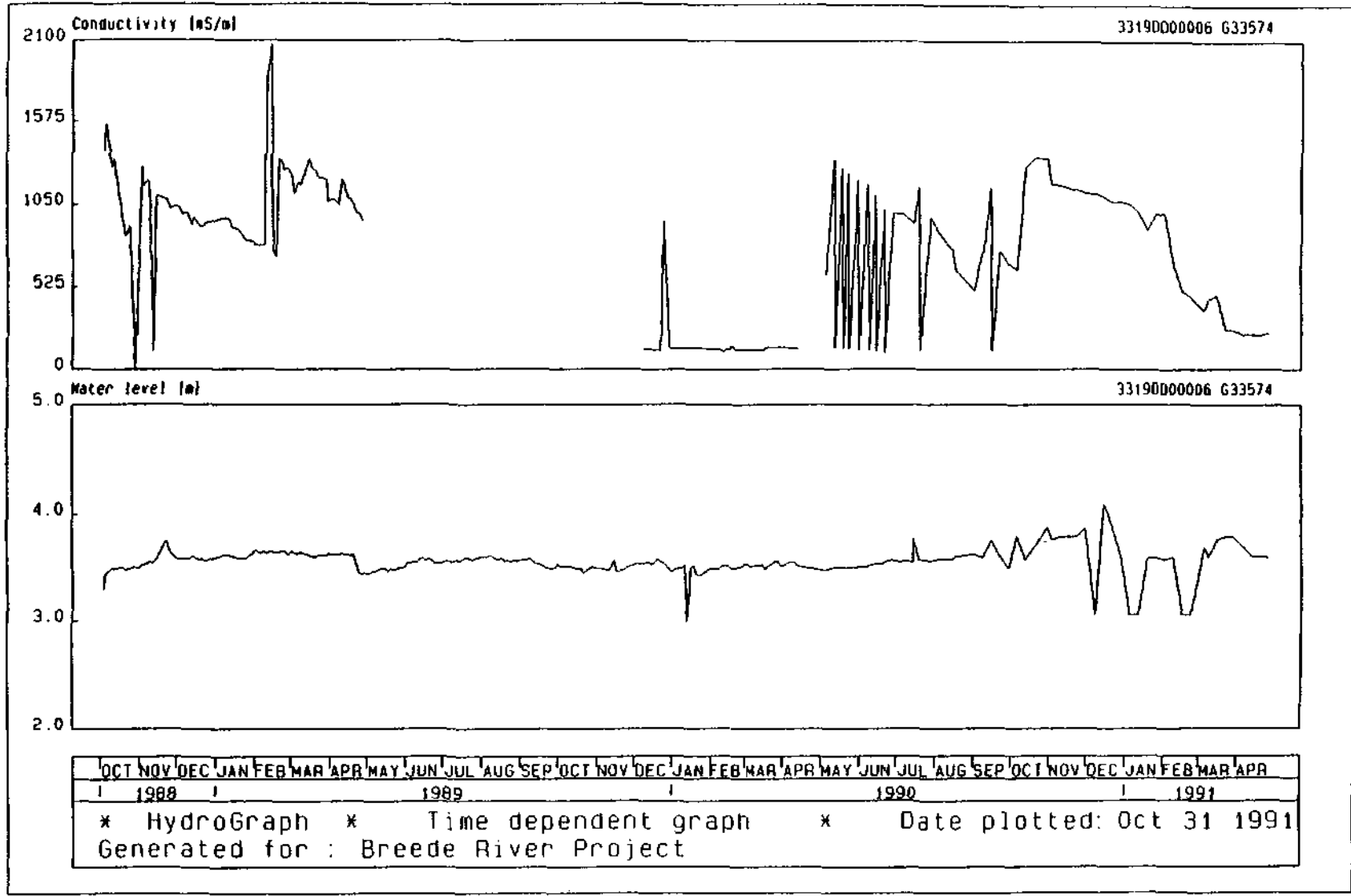

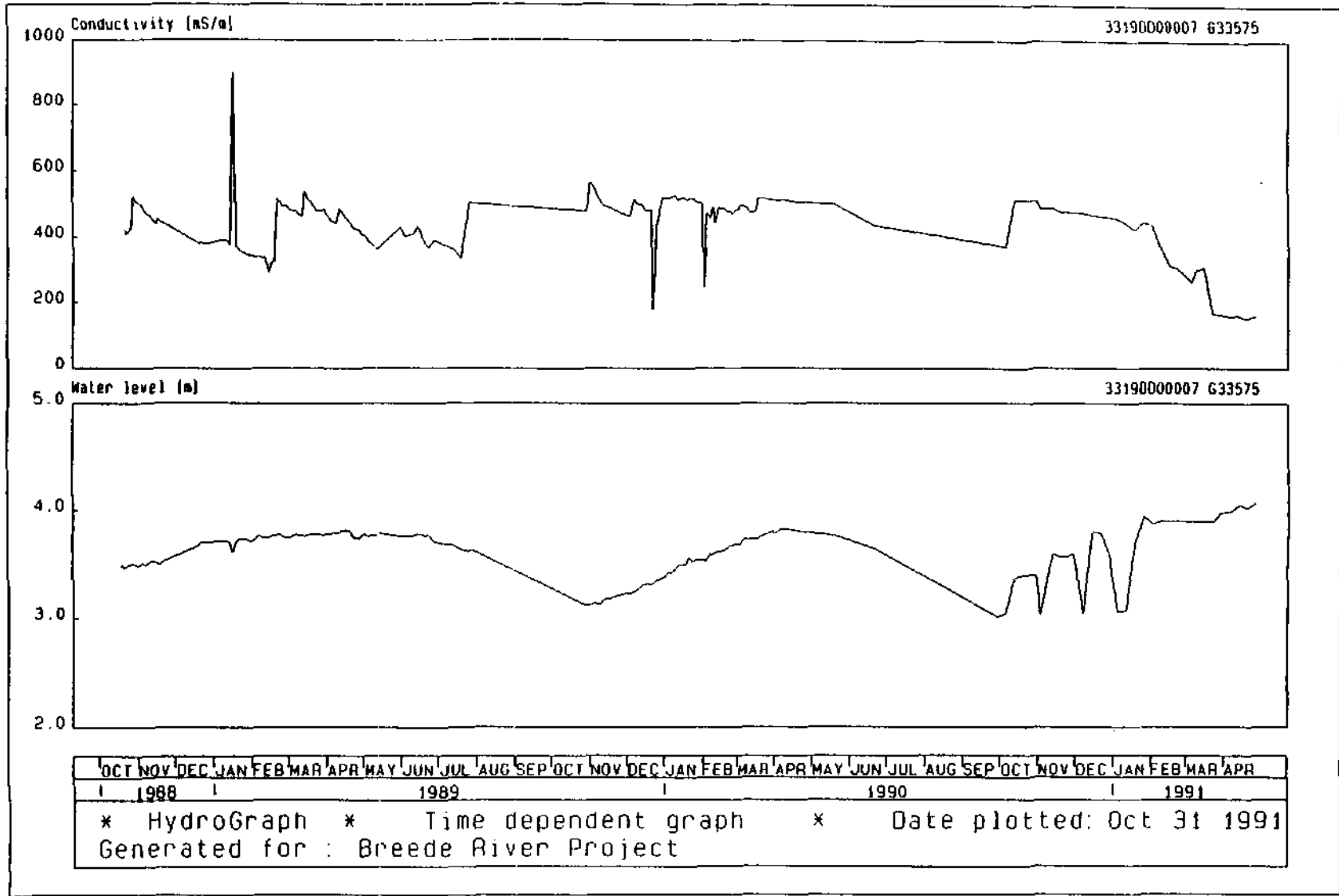

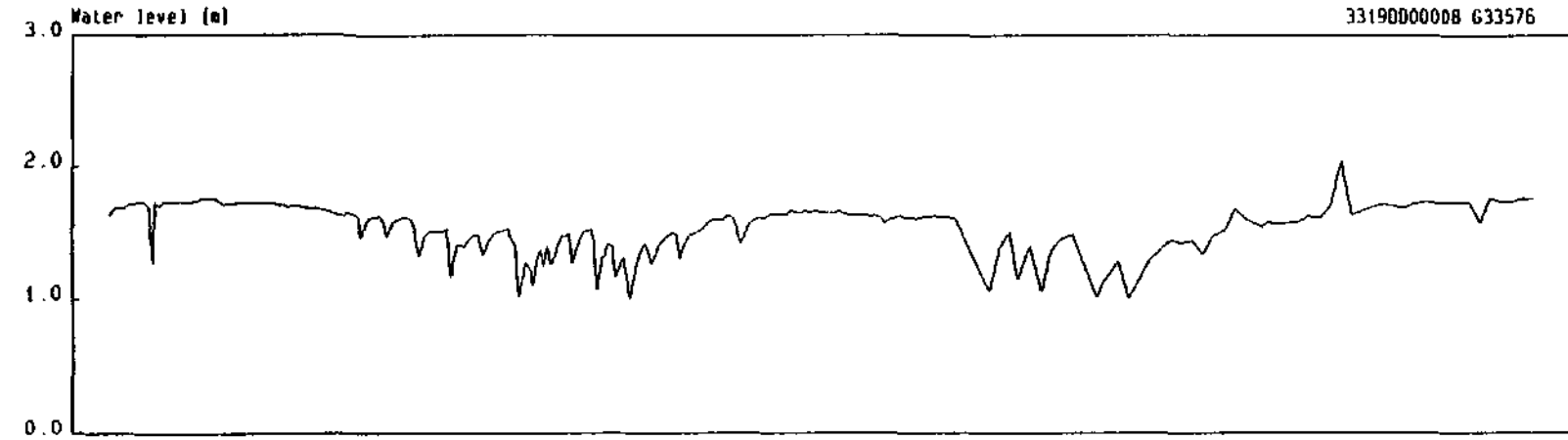
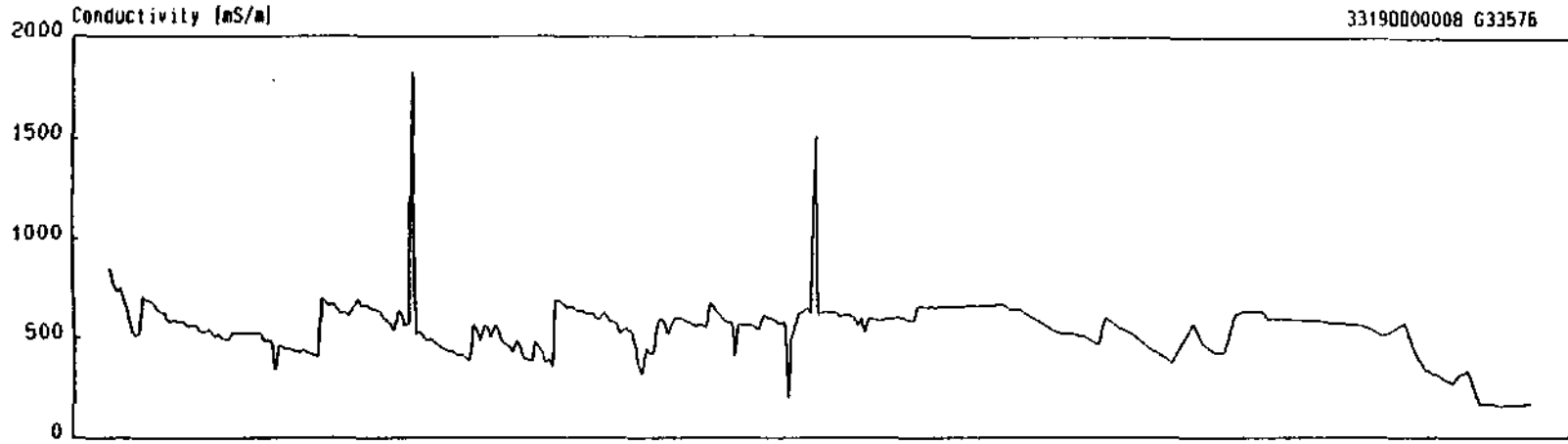

OCT	NOV	DEC	JAN	FEB	MAR	APR	MAY	JUN	JUL	AUG	SEP	OCT	NOV	DEC	JAN	FEB	MAR	APR	MAY	JUN	JUL	AUG	SEP	OCT	NOV	DEC	JAN	FEB	MAR	APR		
1988																																

* HydroGraph * Time dependent graph * Date plotted: Oct 31 1991
 Generated for : Breede River Project

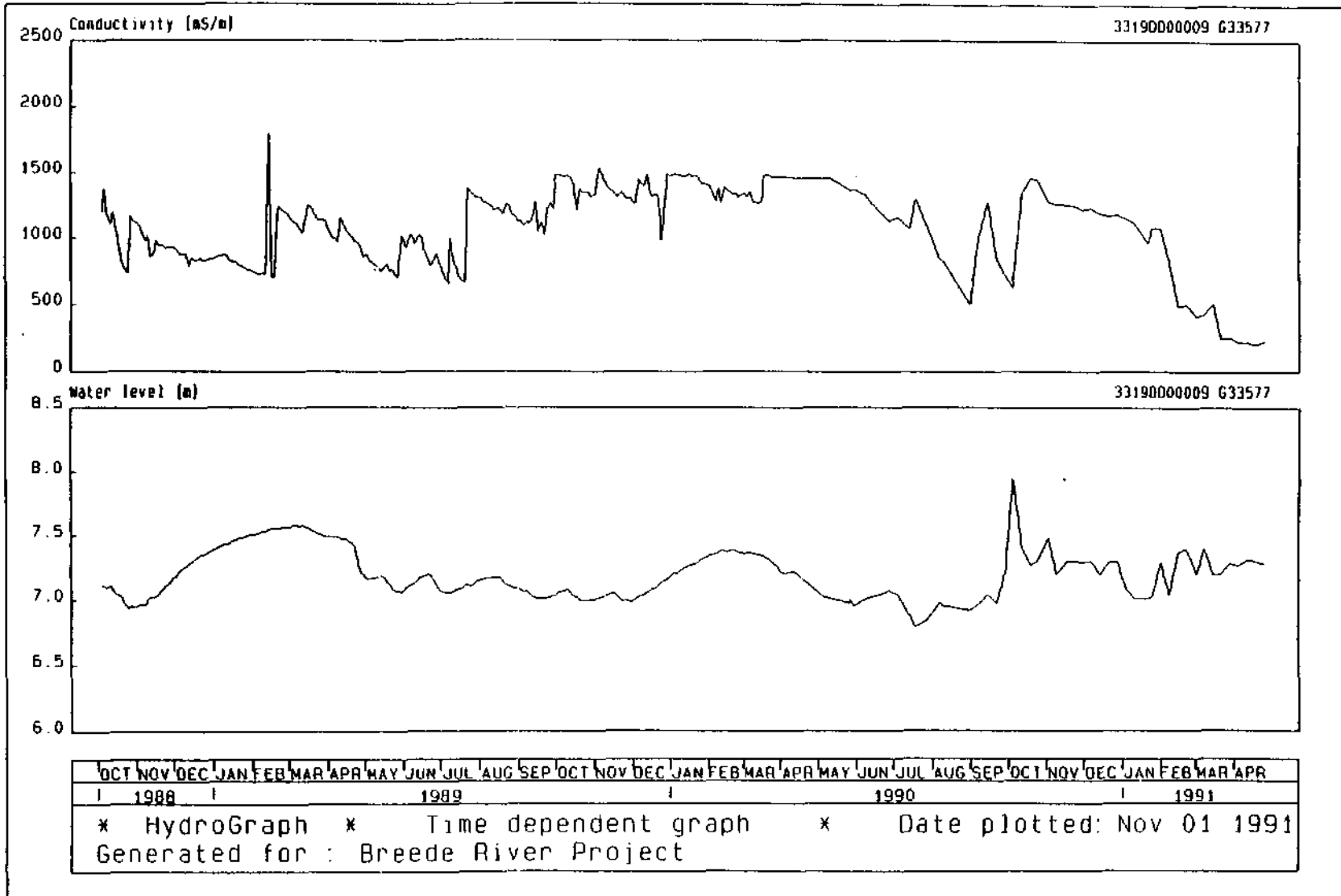

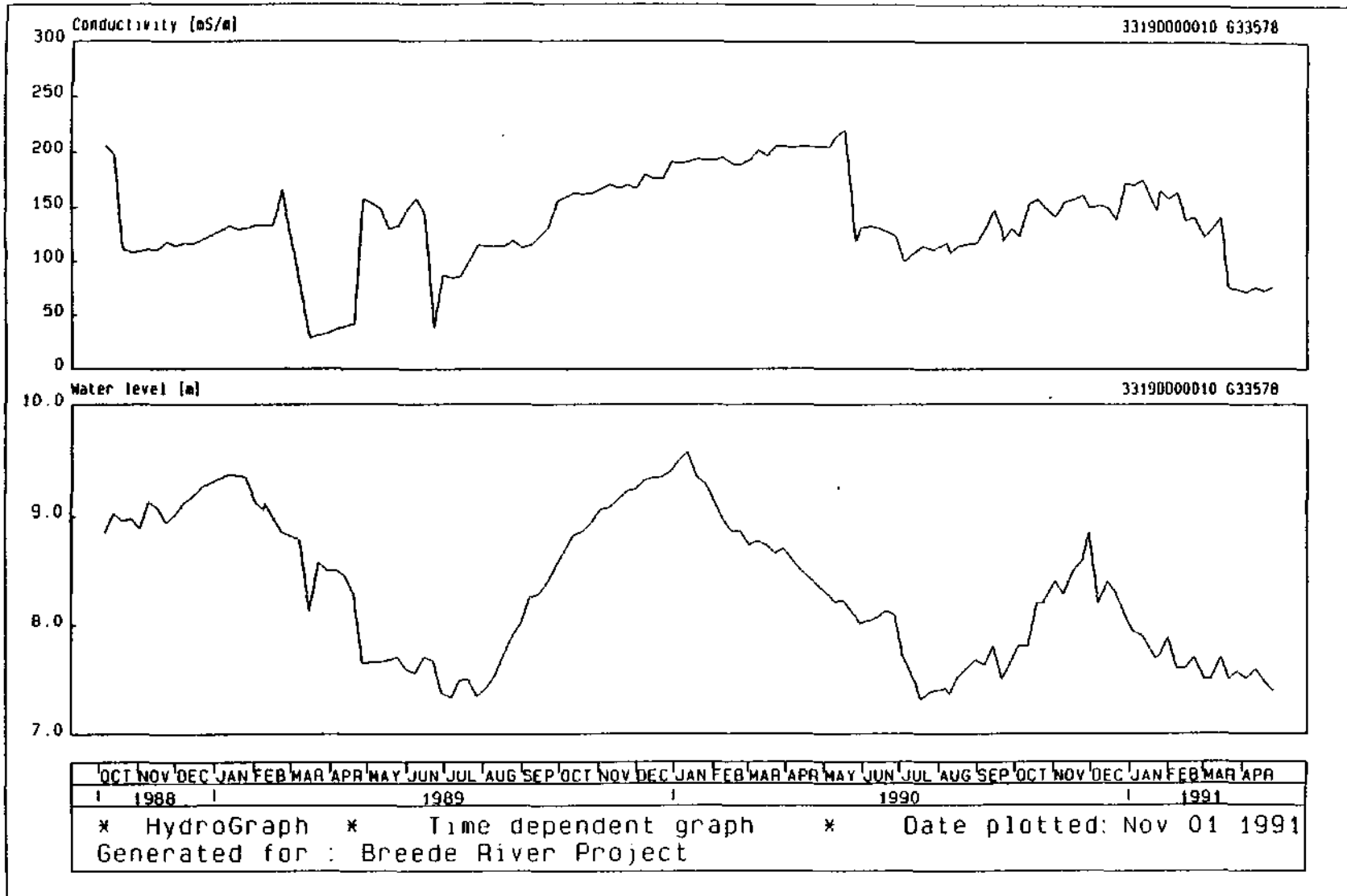

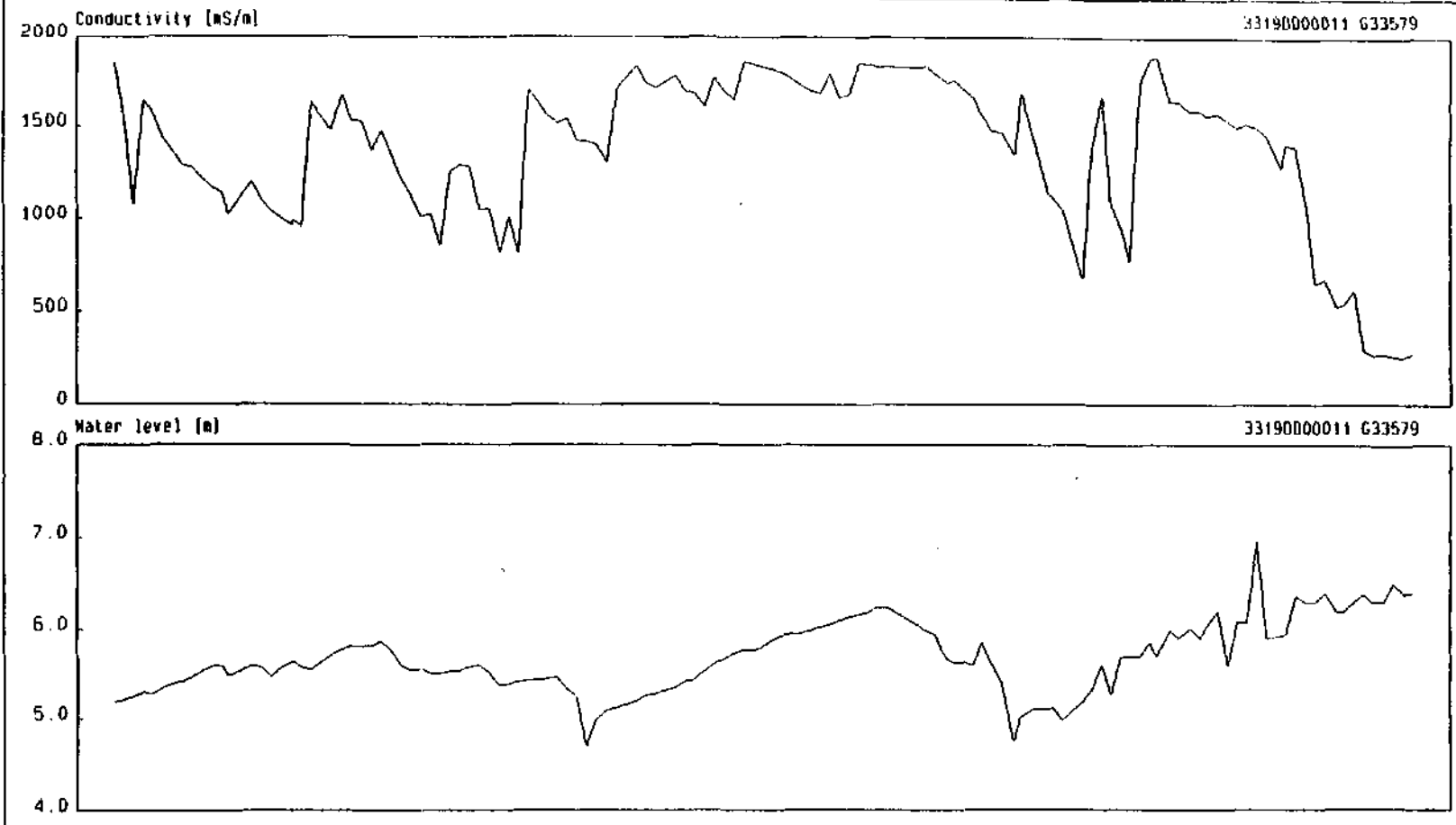

3319000011 G33579

3319000011 G33579

OCT	NOV	DEC	JAN	FEB	MAR	APR	MAY	JUN	JUL	AUG	SEP	OCT	NOV	DEC	JAN	FEB	MAR	APR	MAY	JUN	JUL	AUG	SEP	OCT	NOV	DEC	JAN	FEB	MAR	APR
1988			1989						1990						1991															

* HydroGraph * Time dependent graph * Date plotted: Nov 01 1991
 Generated for : Breede River Project

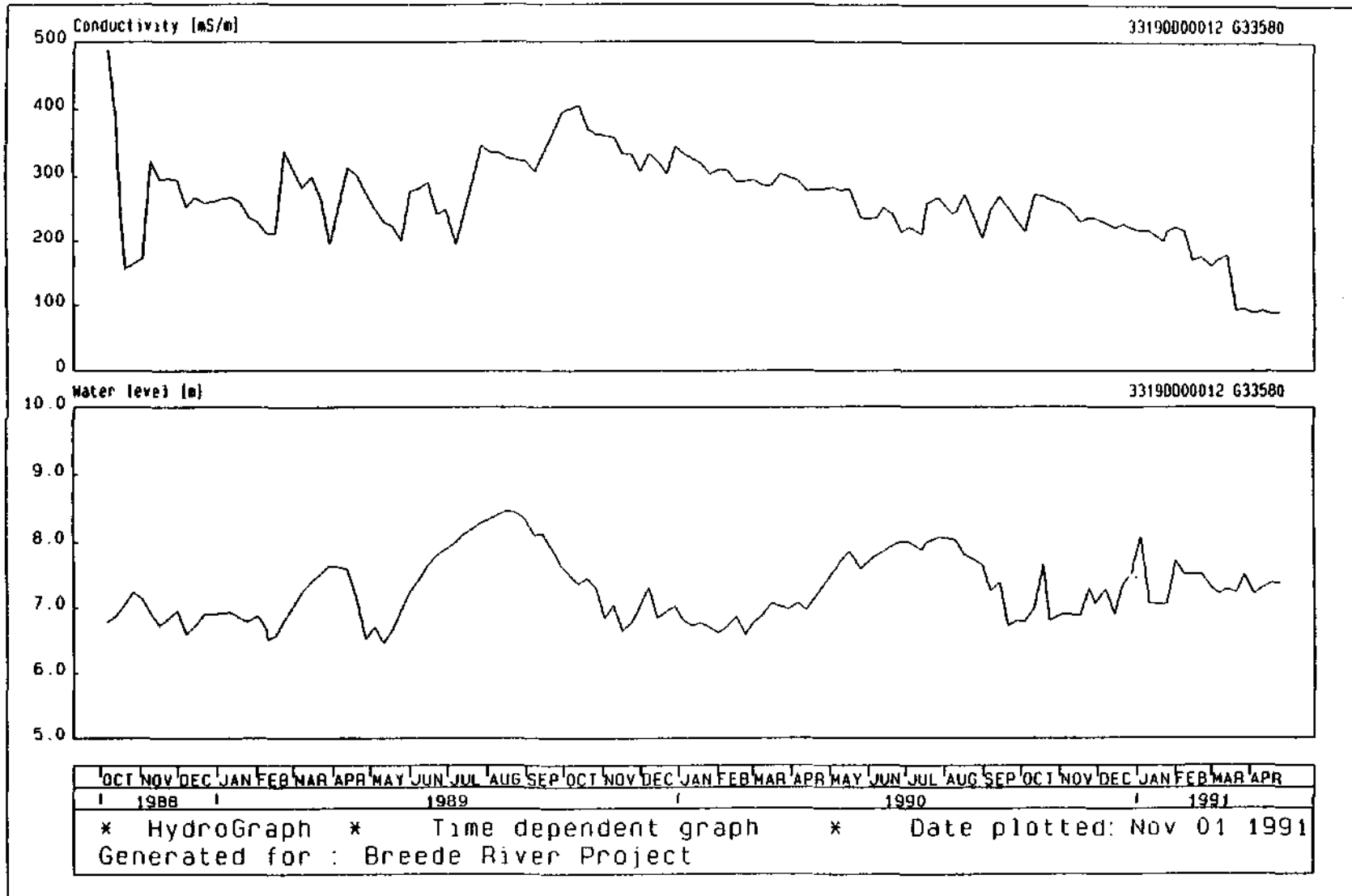

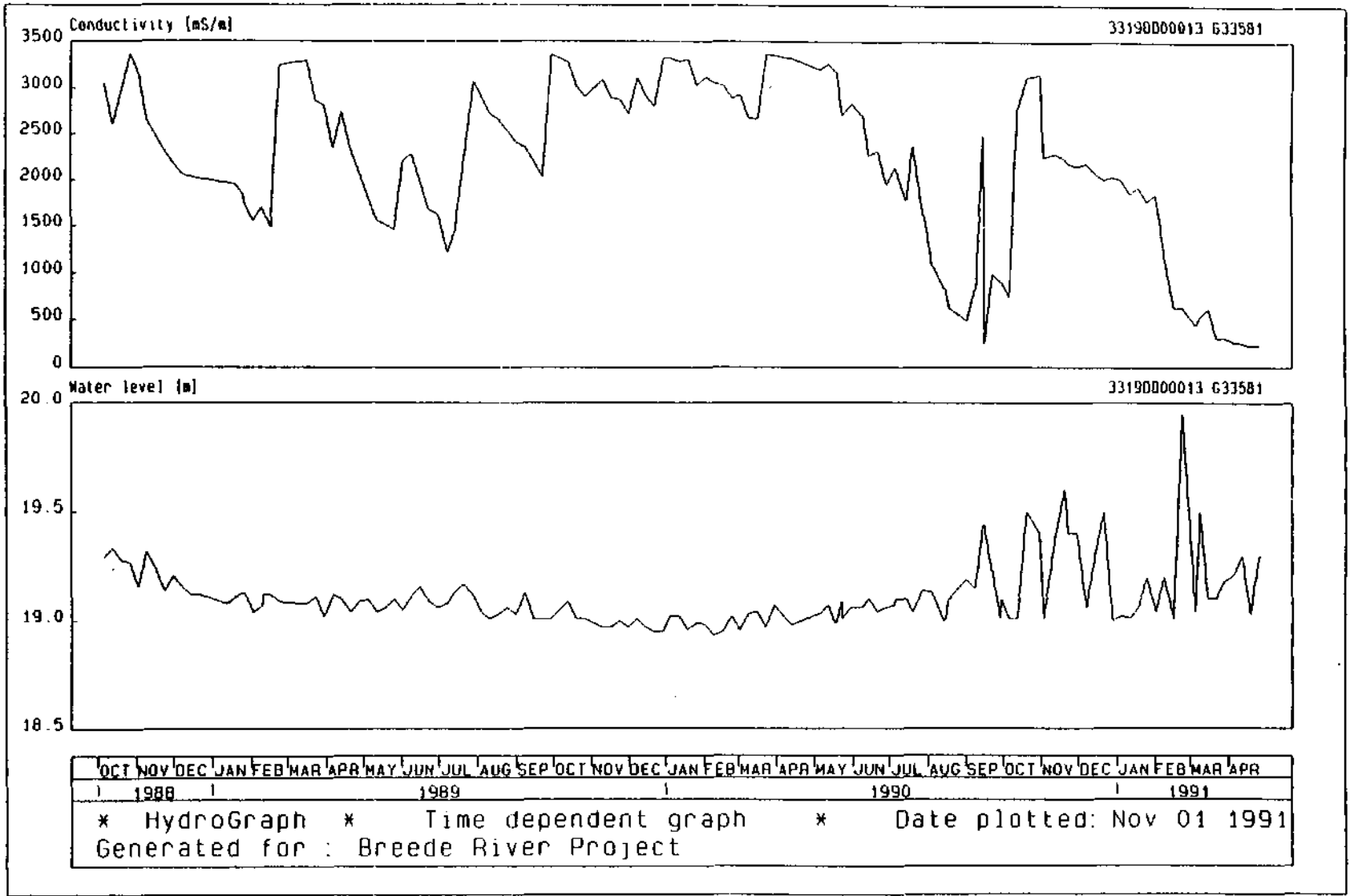

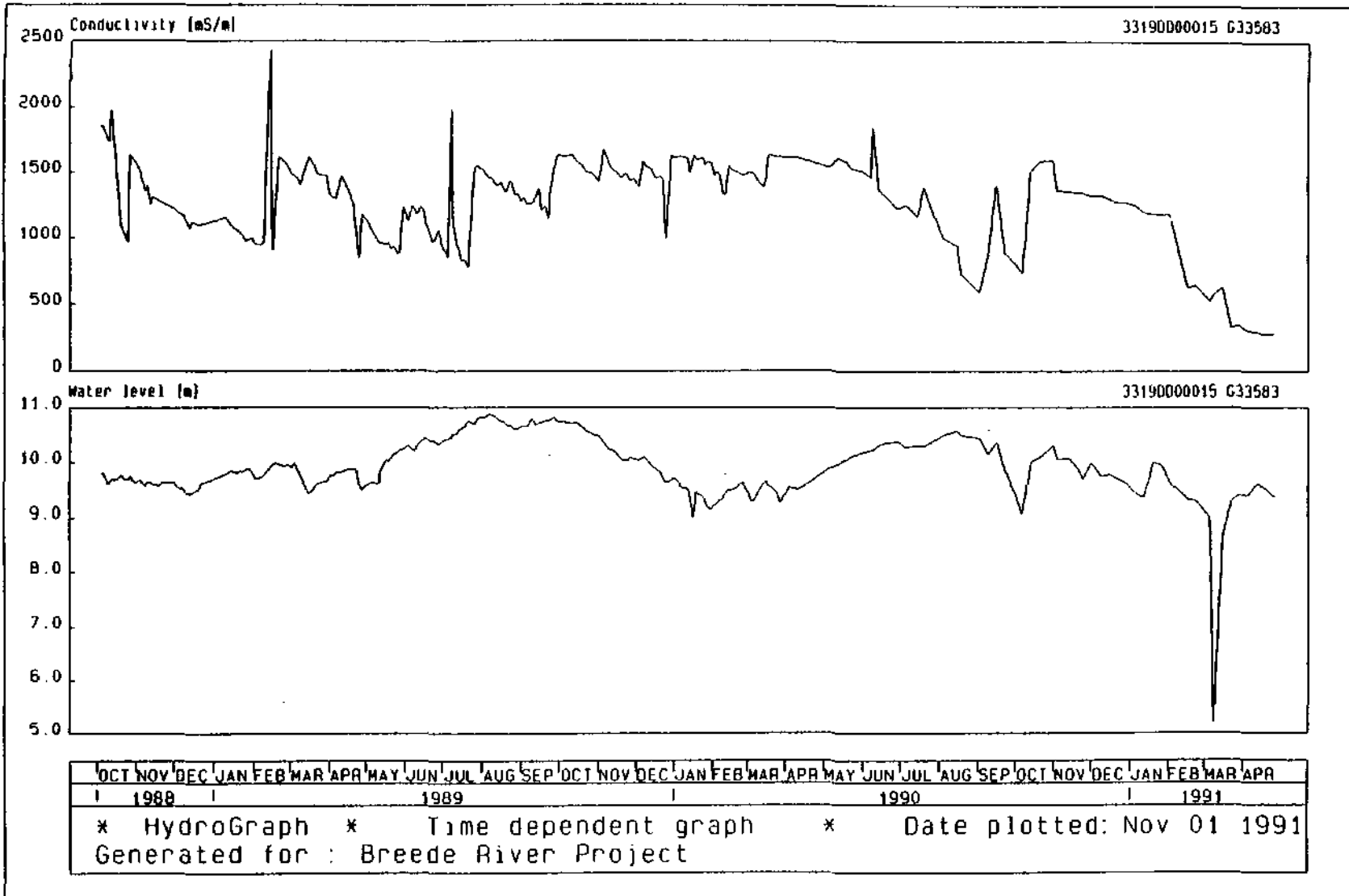

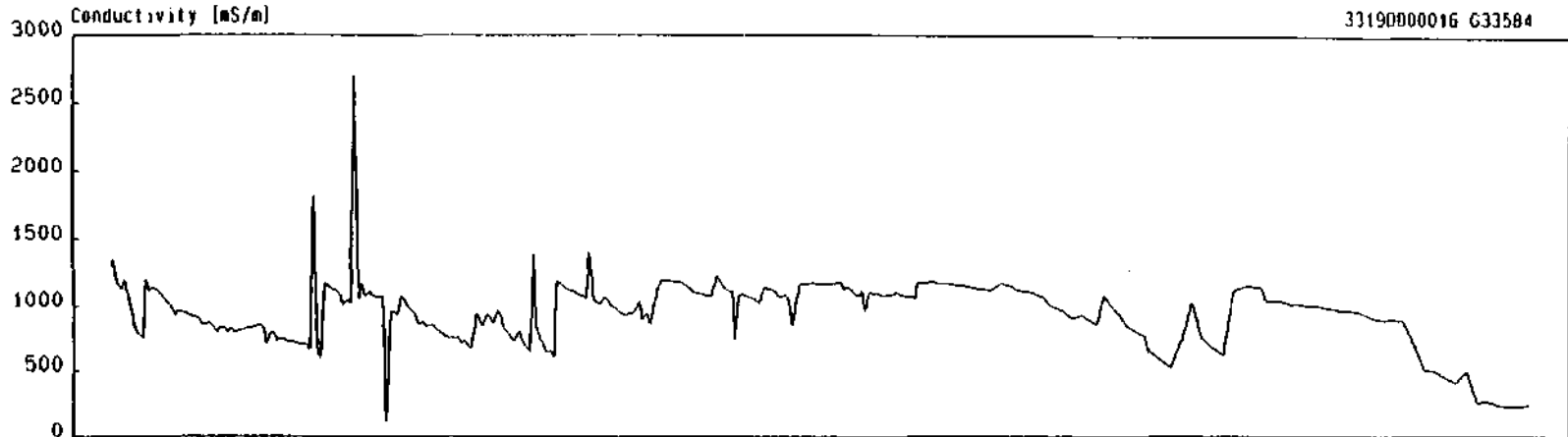

3319000016 G33584

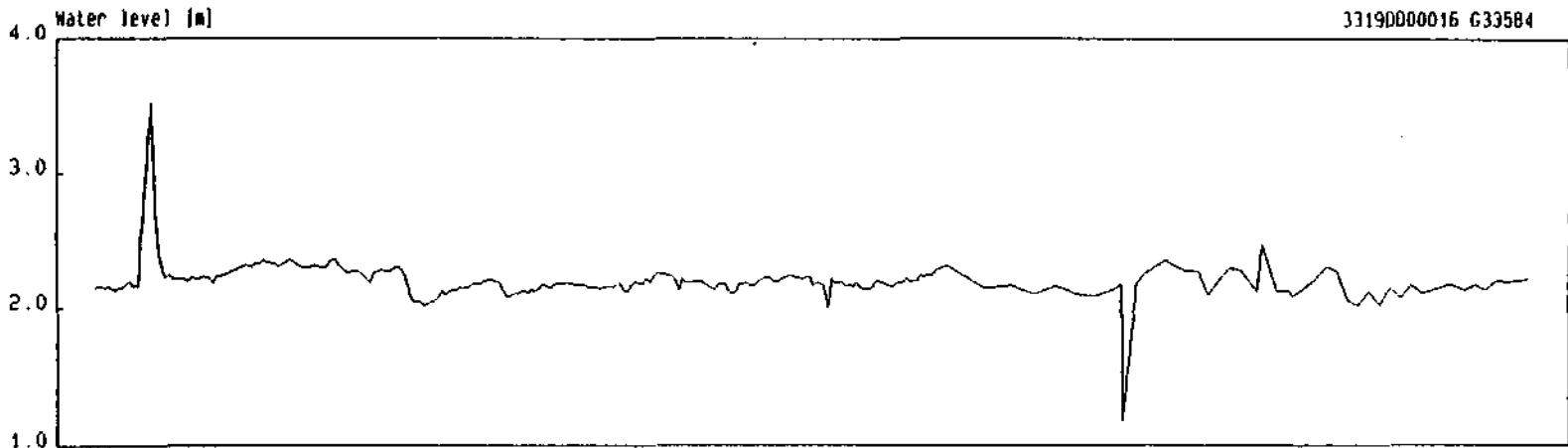

3319000016 G33584

OCT	NOV	DEC	JAN	FEB	MAR	APR	MAY	JUN	JUL	AUG	SEP	OCT	NOV	DEC	JAN	FEB	MAR	APR	MAY	JUN	JUL	AUG	SEP	OCT	NOV	DEC	JAN	FEB	MAR	APR
1988			1989									1990						1991												

* HydroGraph * Time dependent graph * Date plotted: Nov 01 1991
 Generated for : Breede River Project

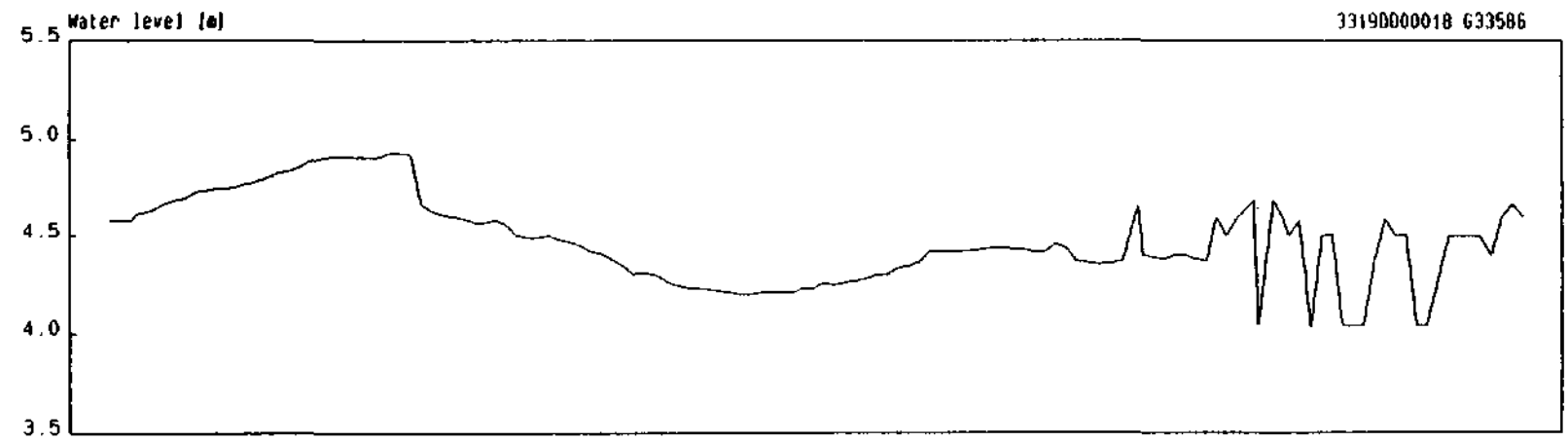
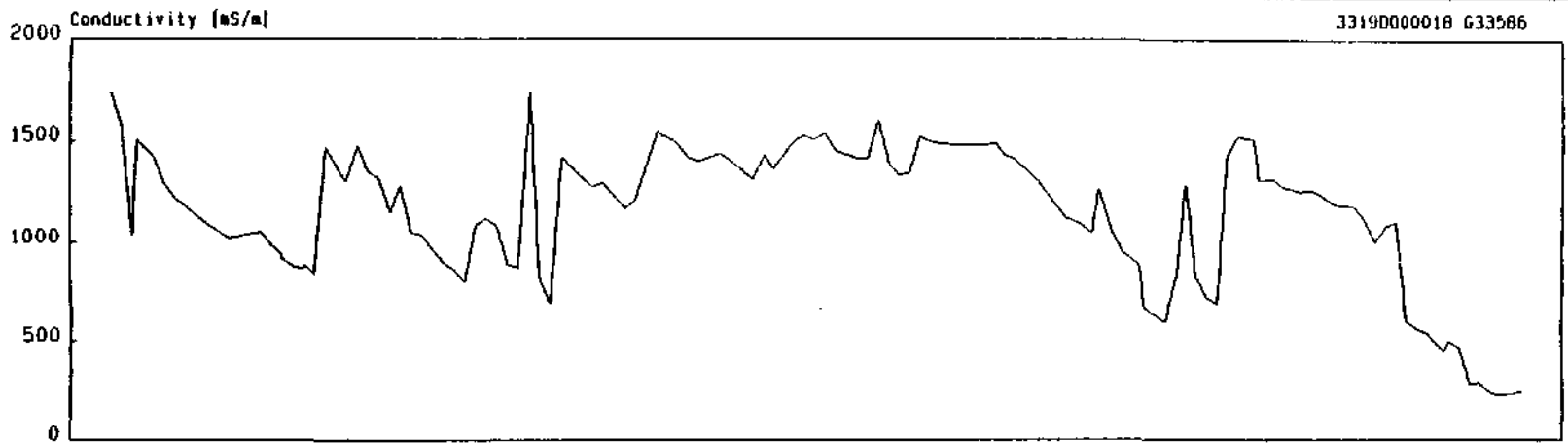

OCT	NOV	DEC	JAN	FEB	MAR	APR	MAY	JUN	JUL	AUG	SEP	OCT	NOV	DEC	JAN	FEB	MAR	APR	MAY	JUN	JUL	AUG	SEP	OCT	NOV	DEC	JAN	FEB	MAR	APR																	
1988												1989												1990												1991											

* HydroGraph * Time dependent graph * Date plotted: Nov 01 1991
 Generated for : Breede River Project

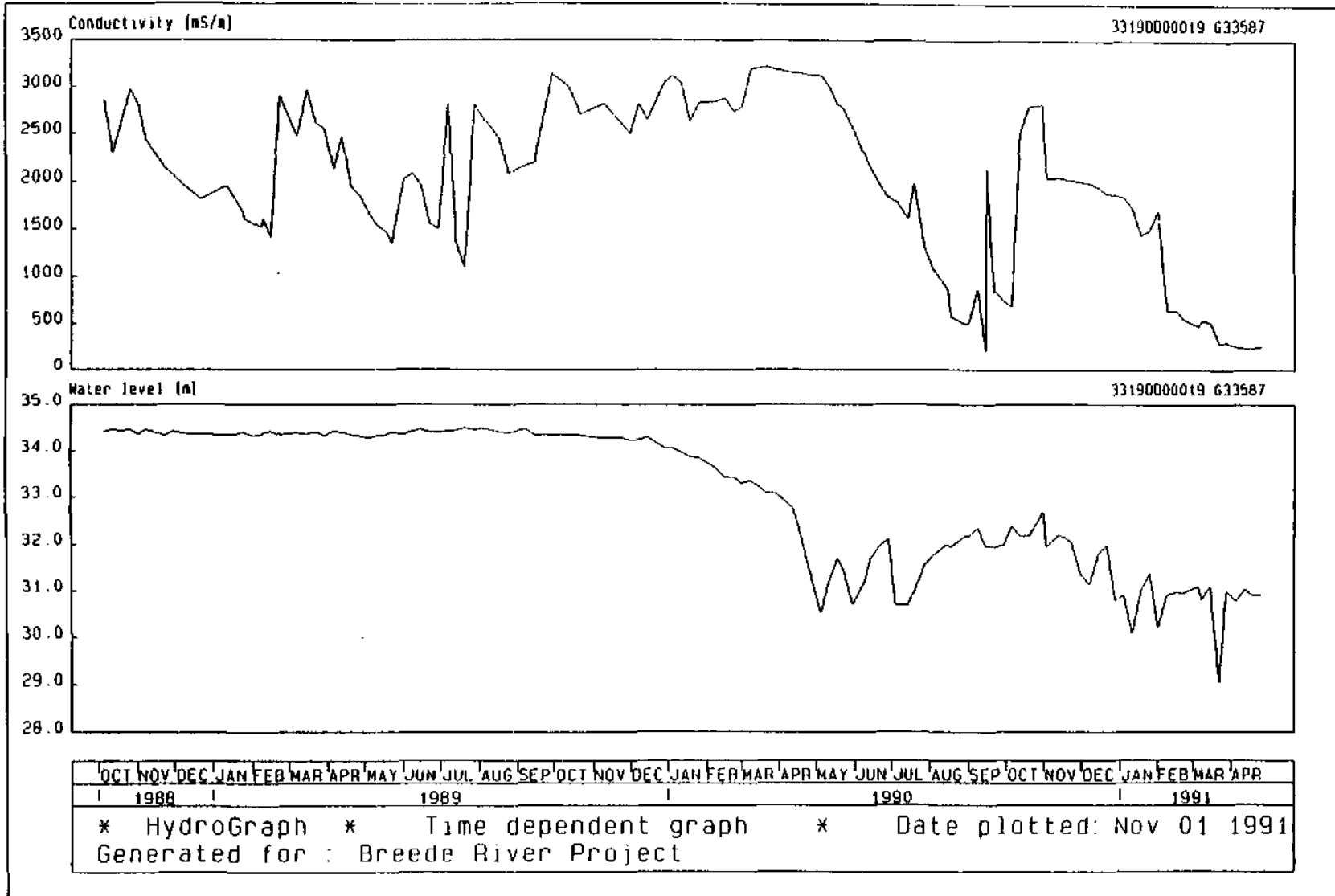

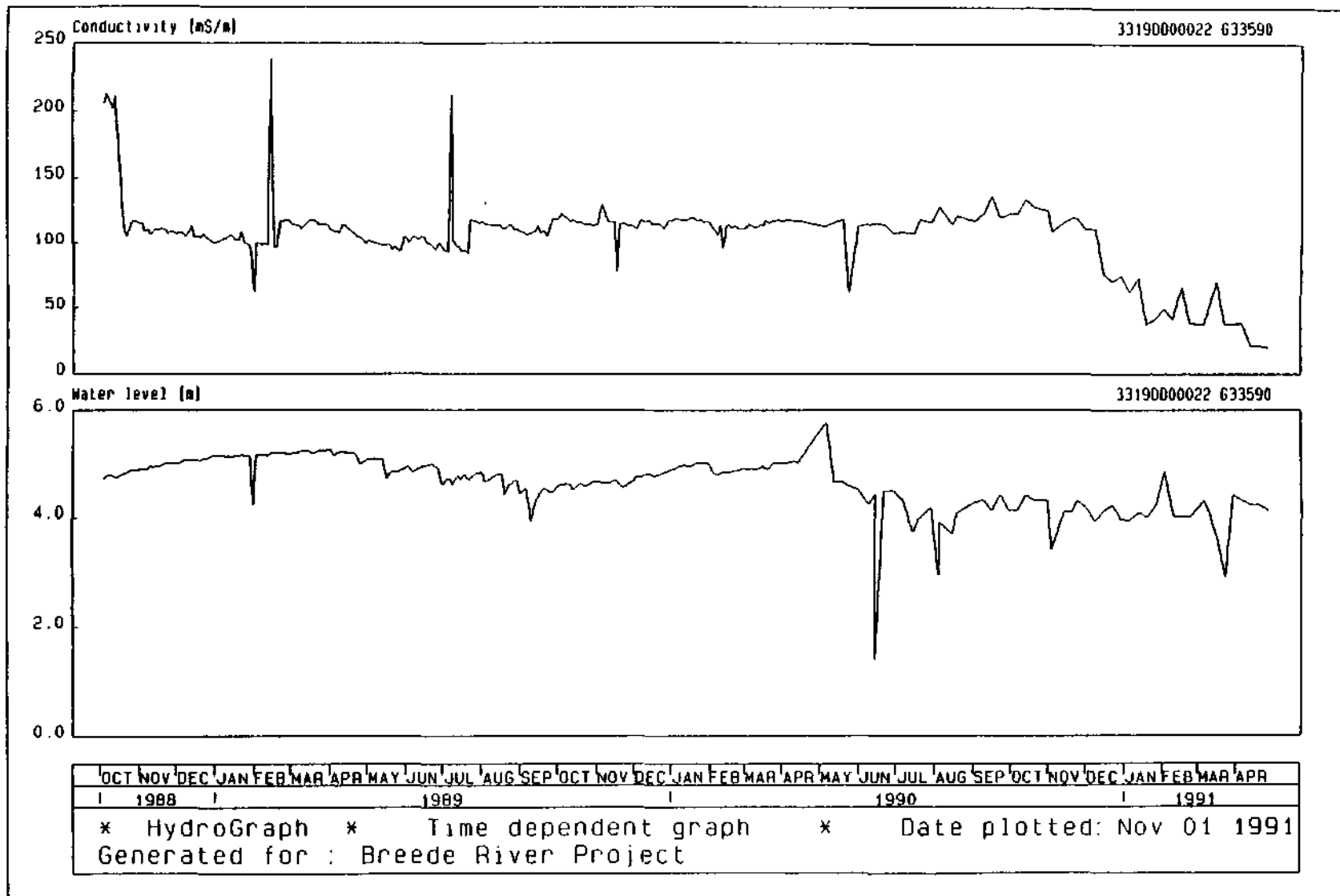

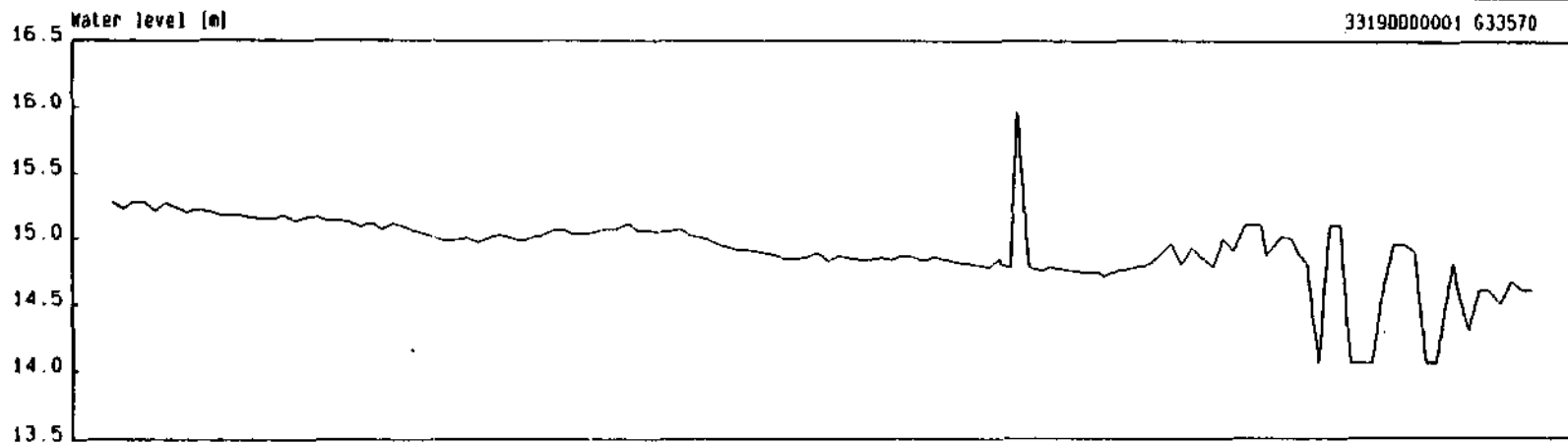
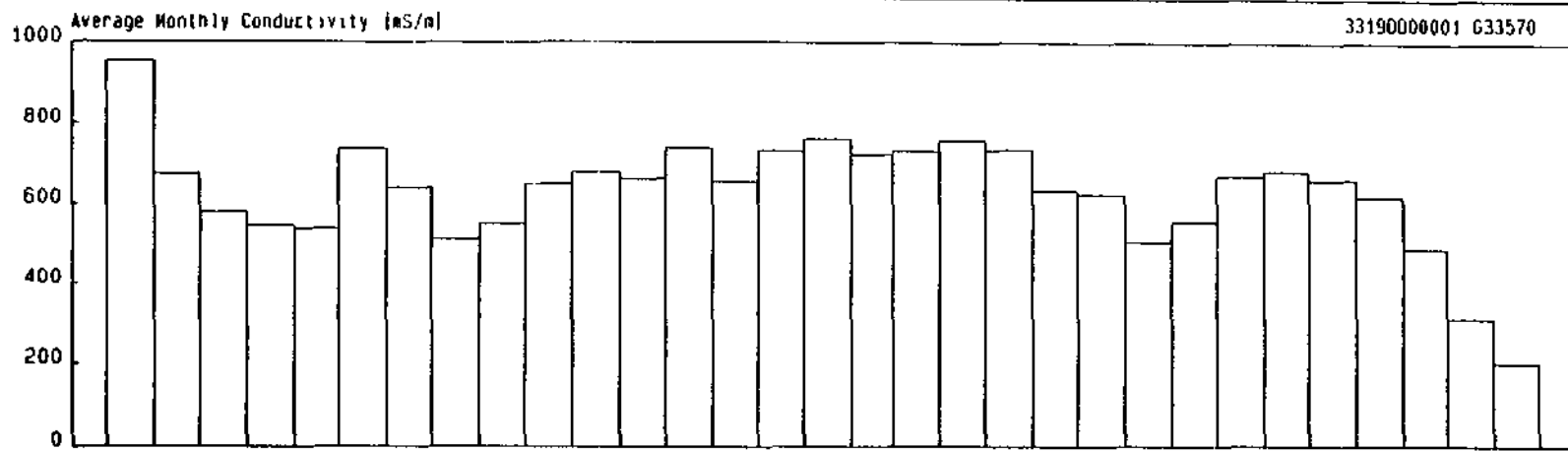

OCT	NOV	DEC	JAN	FEB	MAR	APR	MAY	JUN	JUL	AUG	SEP	OCT	NOV	DEC	JAN	FEB	MAR	APR	MAY	JUN	JUL	AUG	SEP	OCT	NOV	DEC	JAN	FEB	MAR	APR
1988			1989									1990						1991												

* HydroGraph * Time dependent graph * Date plotted: Oct 31 1991
 Generated for : Breede River Project

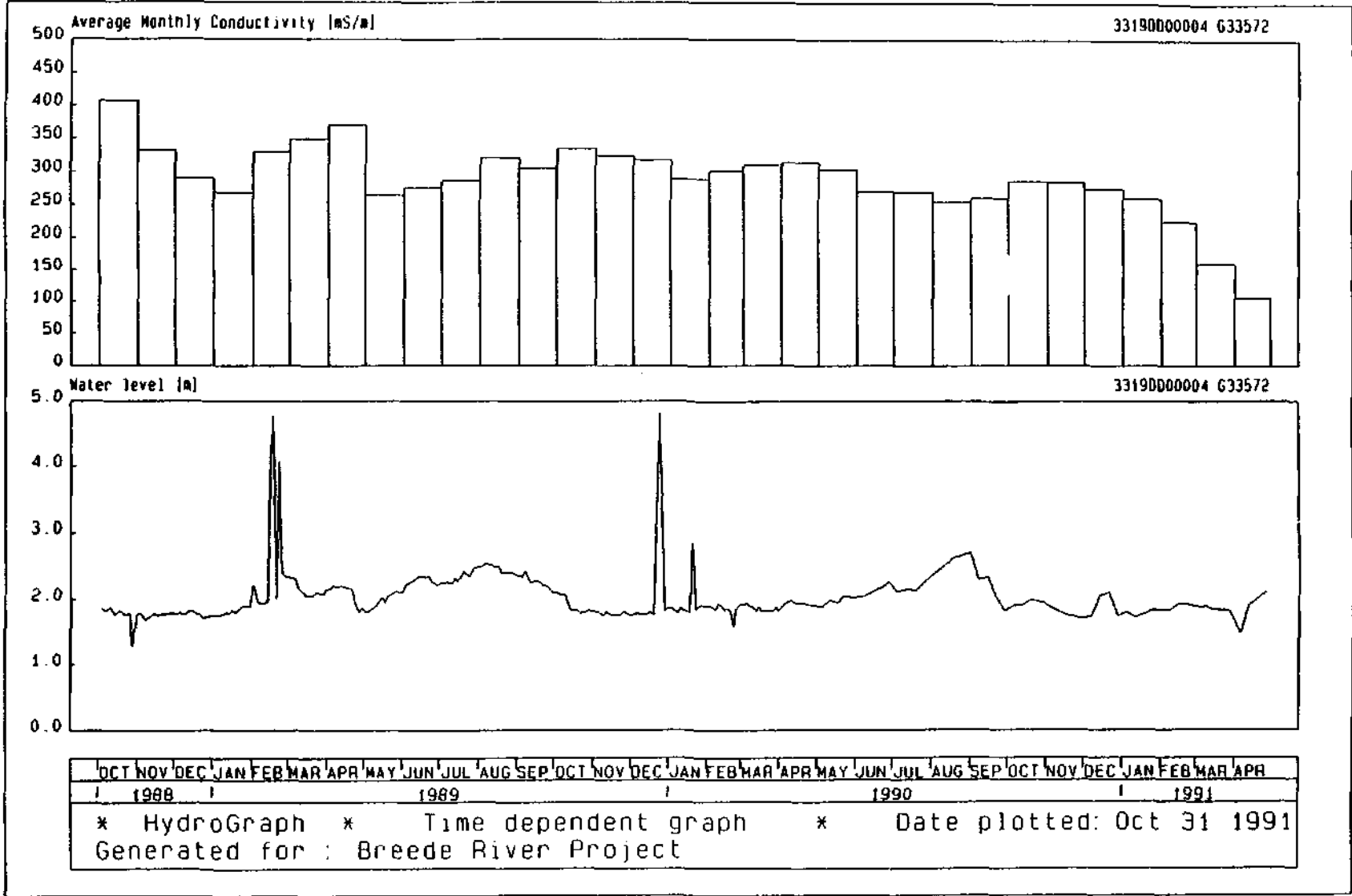

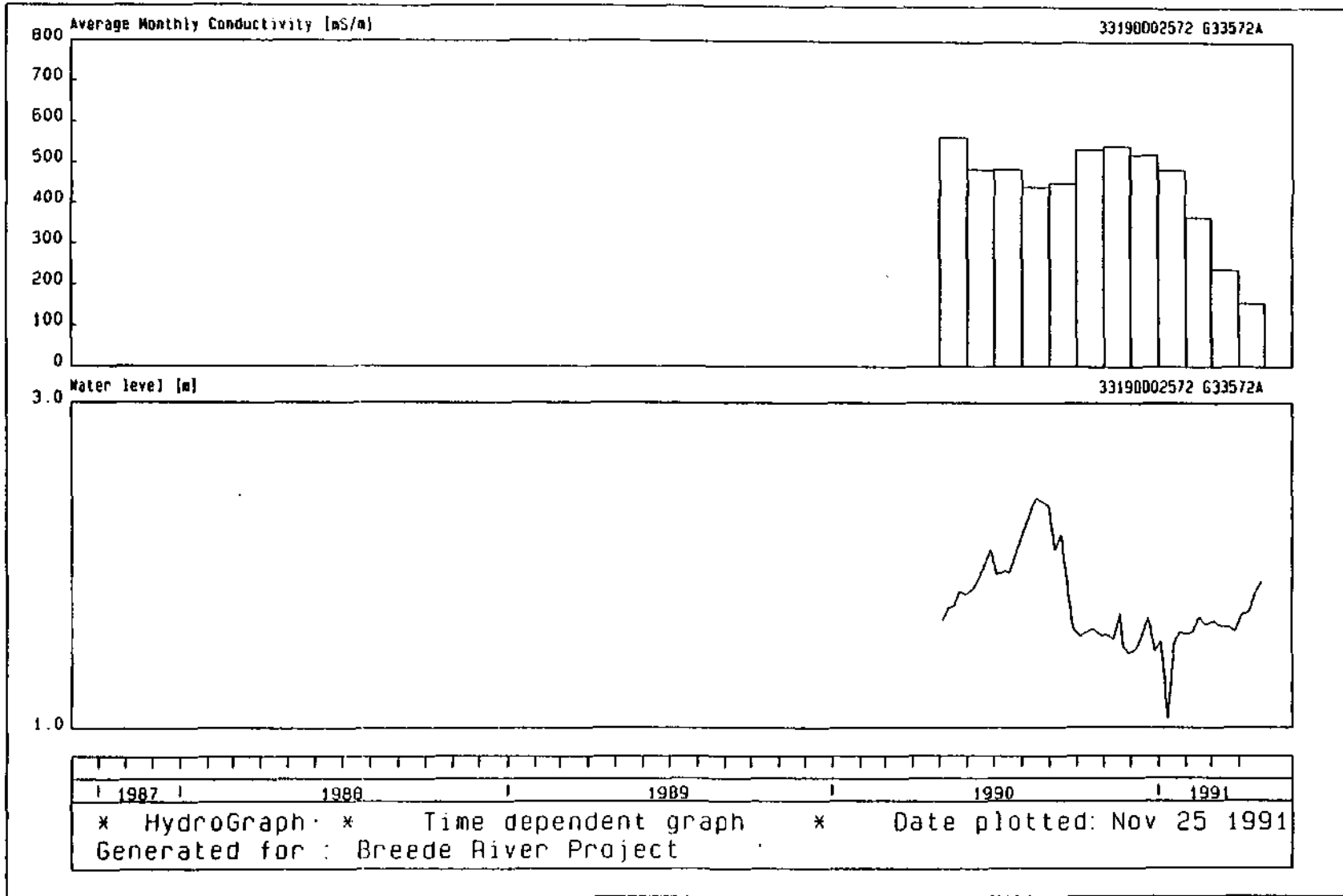

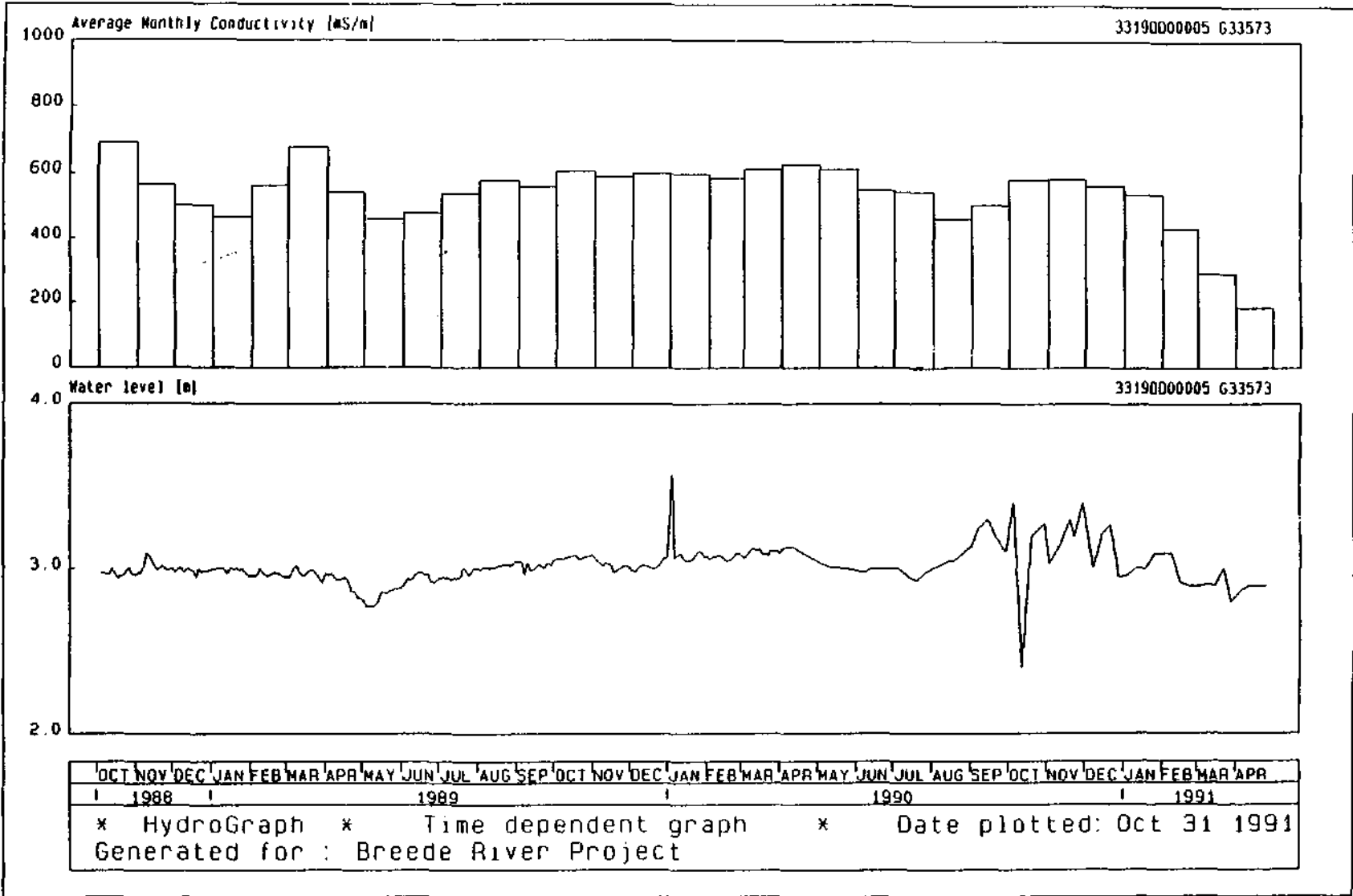

Average Monthly Conductivity (mS/m)

33190002573 633573A

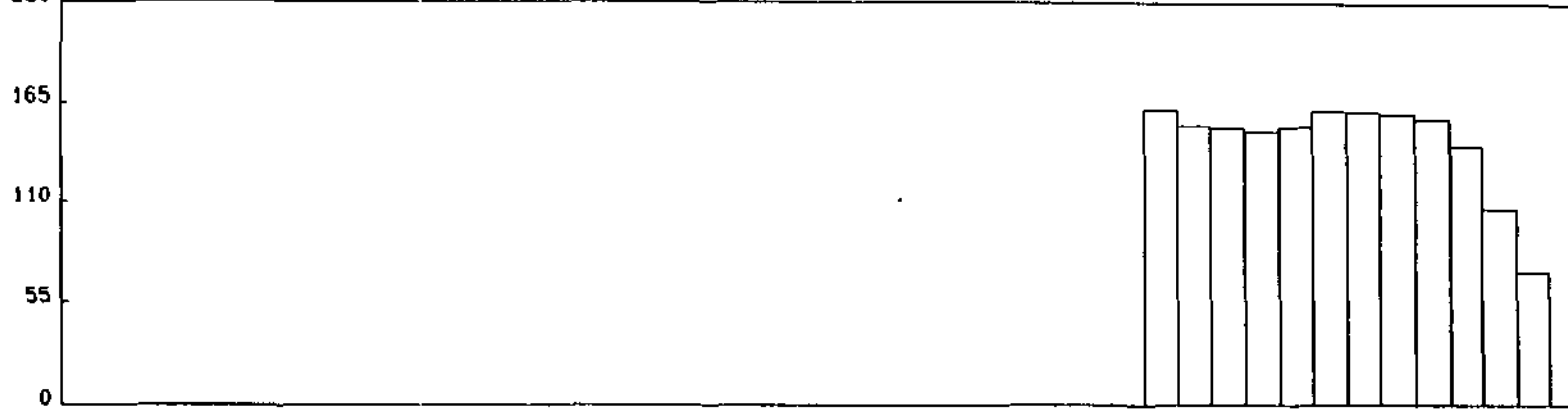

Water level (m)

33190002573 633573A

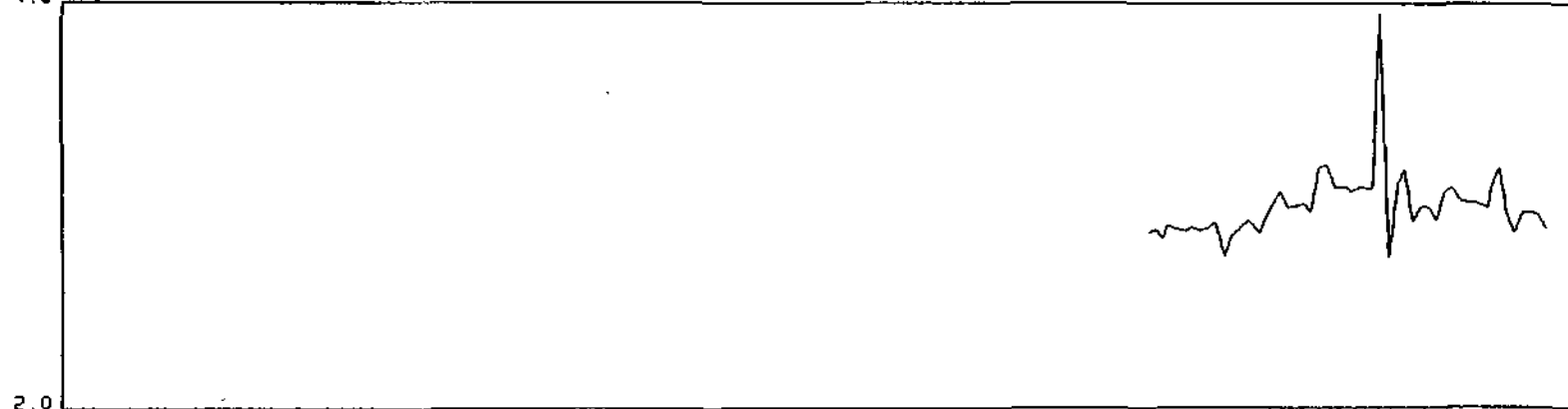

| 1987 | 1988 | 1989 | 1990 | 1991 |
* HydroGraph * Time dependent graph * Date plotted: Nov 25 1991
Generated for : Breede River Project

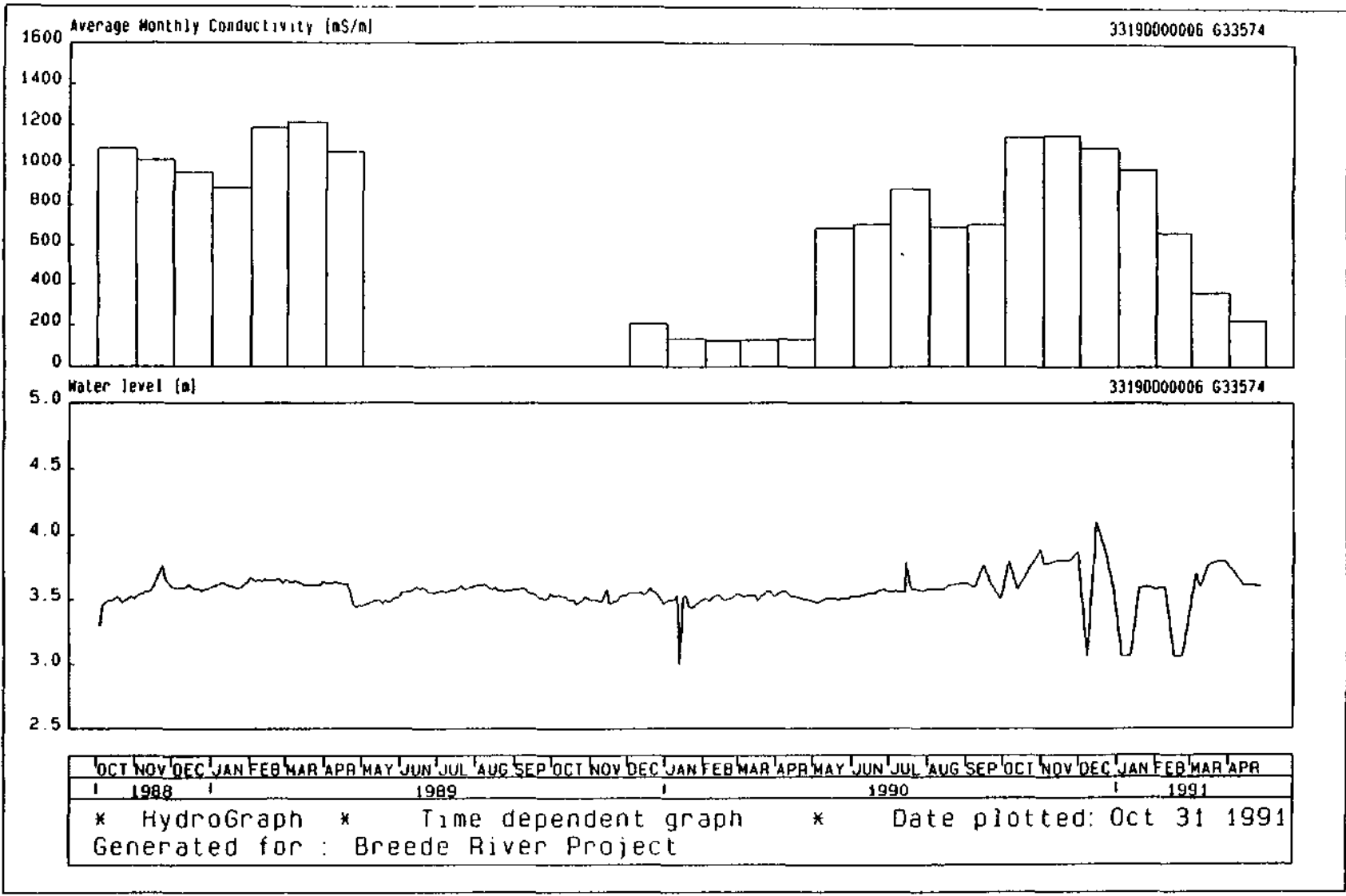

OCT NOV DEC JAN FEB MAR APR MAY JUN JUL AUG SEP OCT NOV DEC JAN FEB MAR APR
 | 1988 | 1989 | 1990 | 1991 |
 * HydroGraph * Time dependent graph * Date plotted: Oct 31 1991
 Generated for : Breede River Project

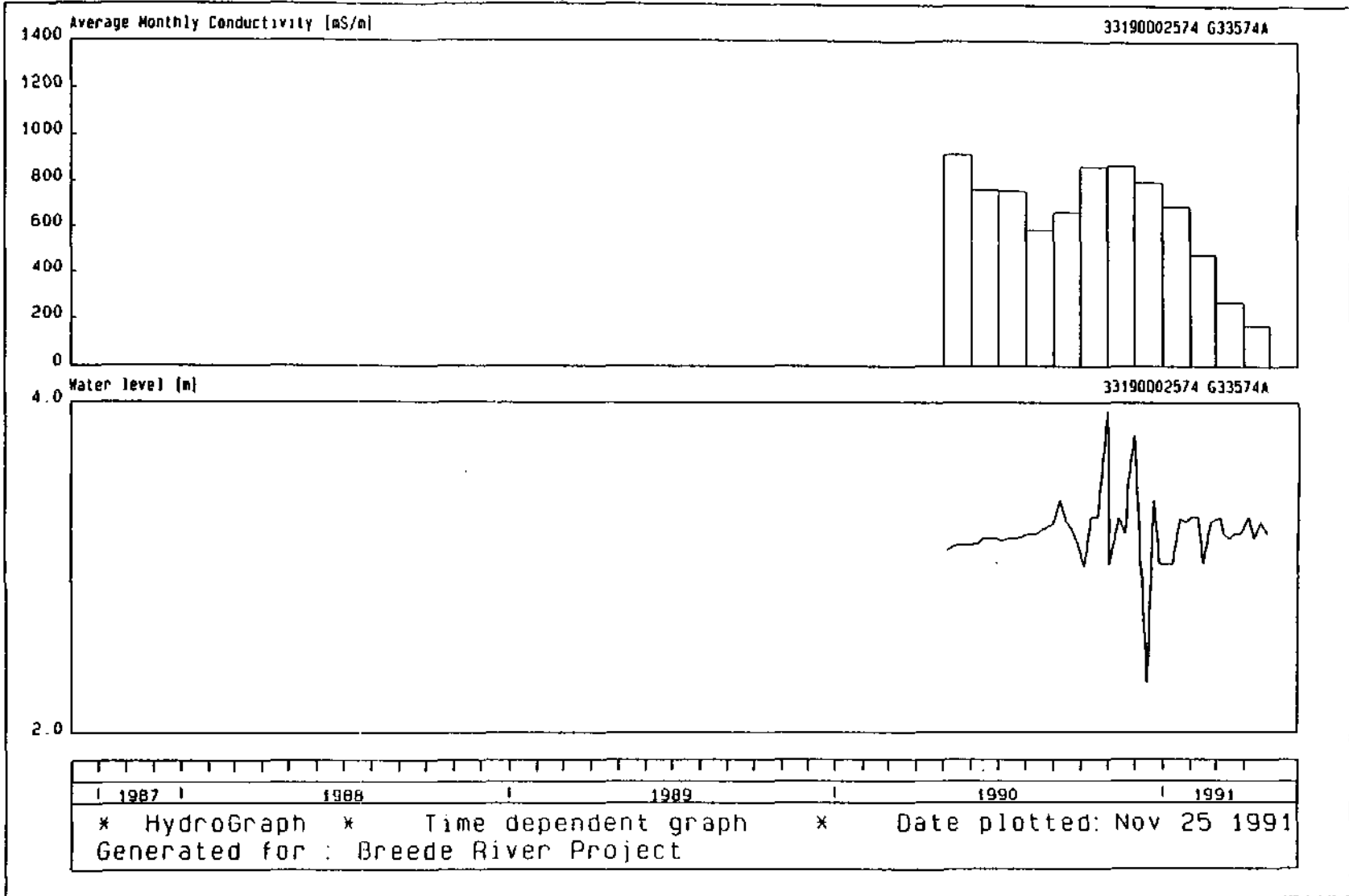

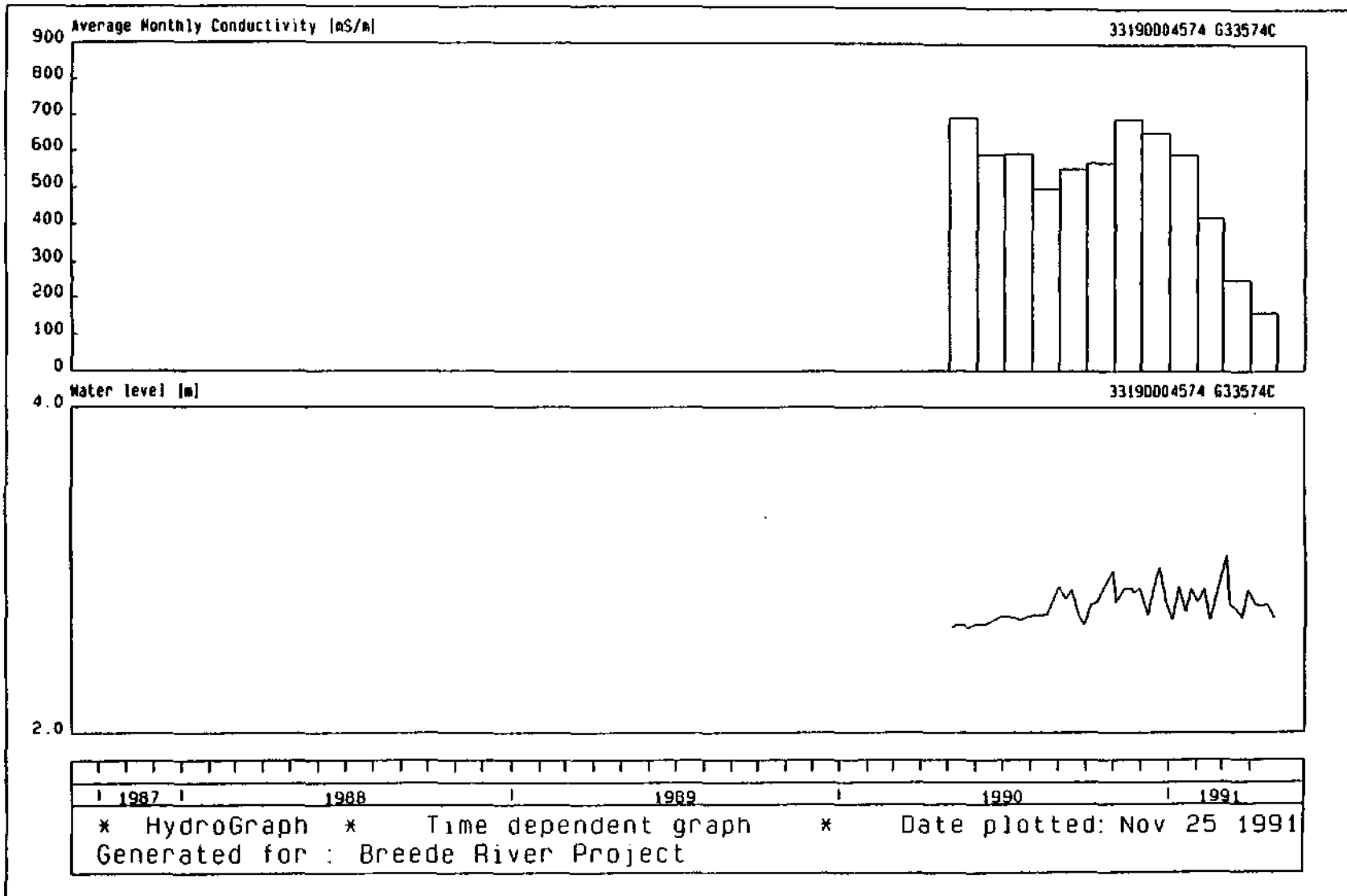

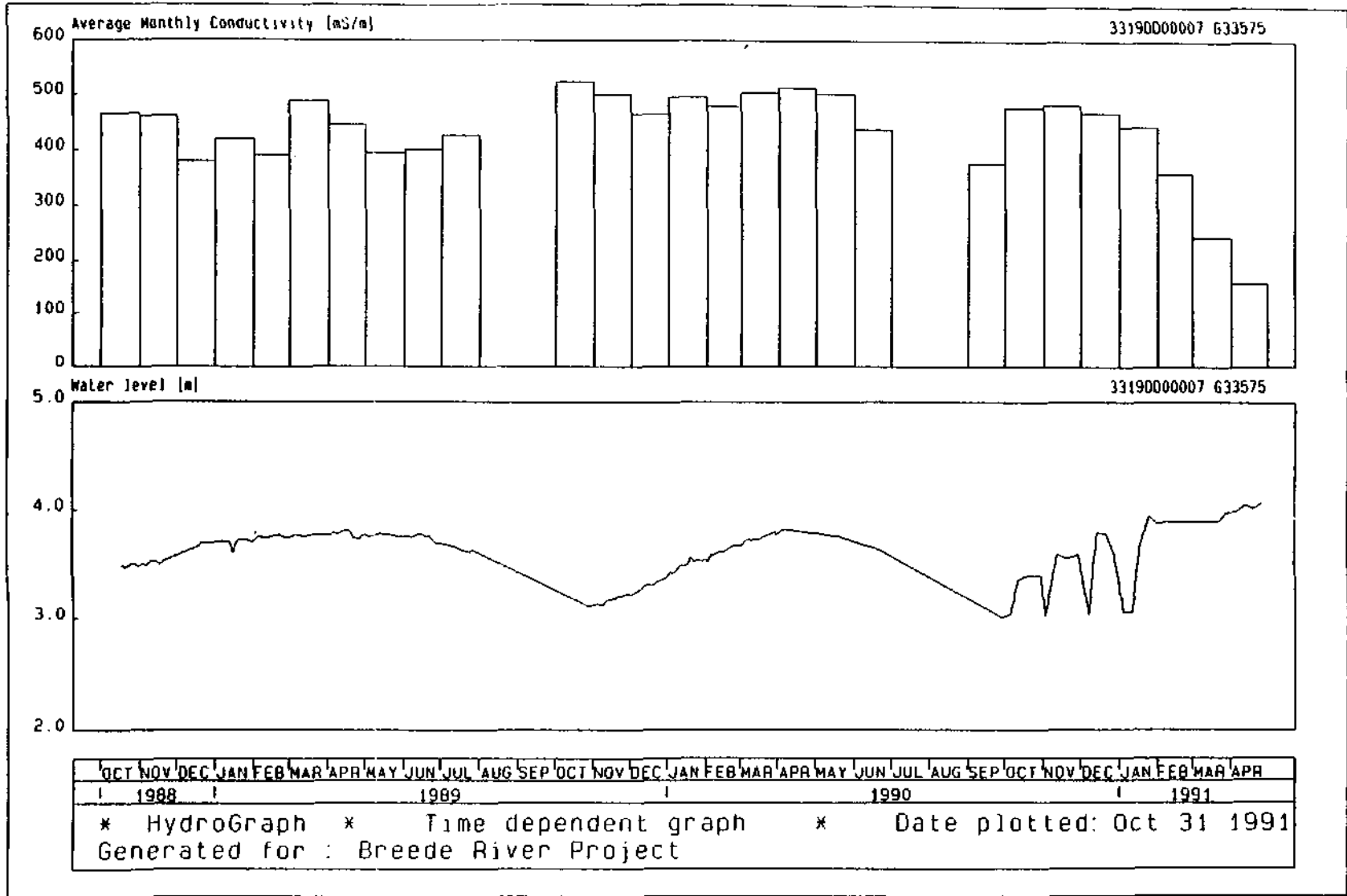

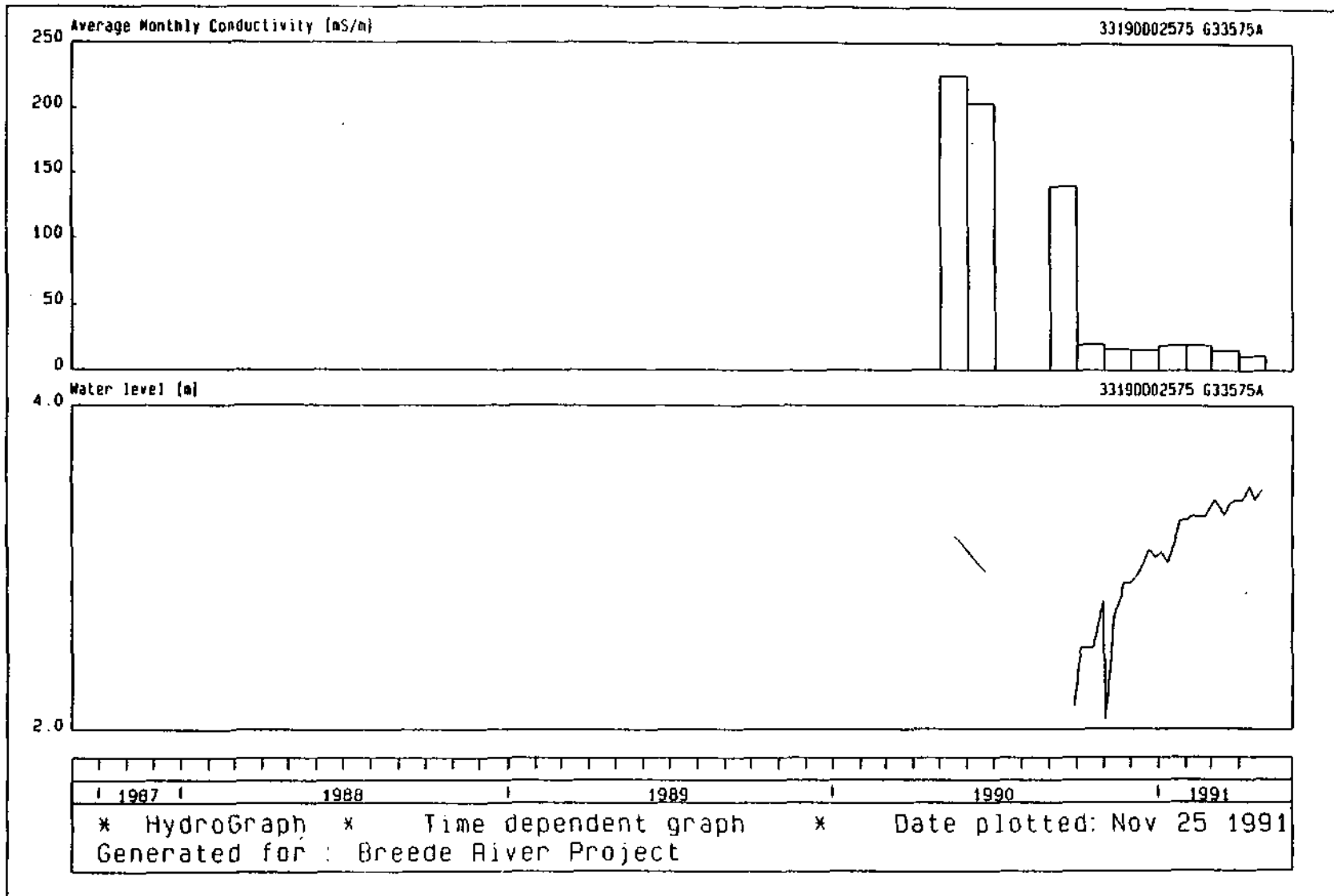

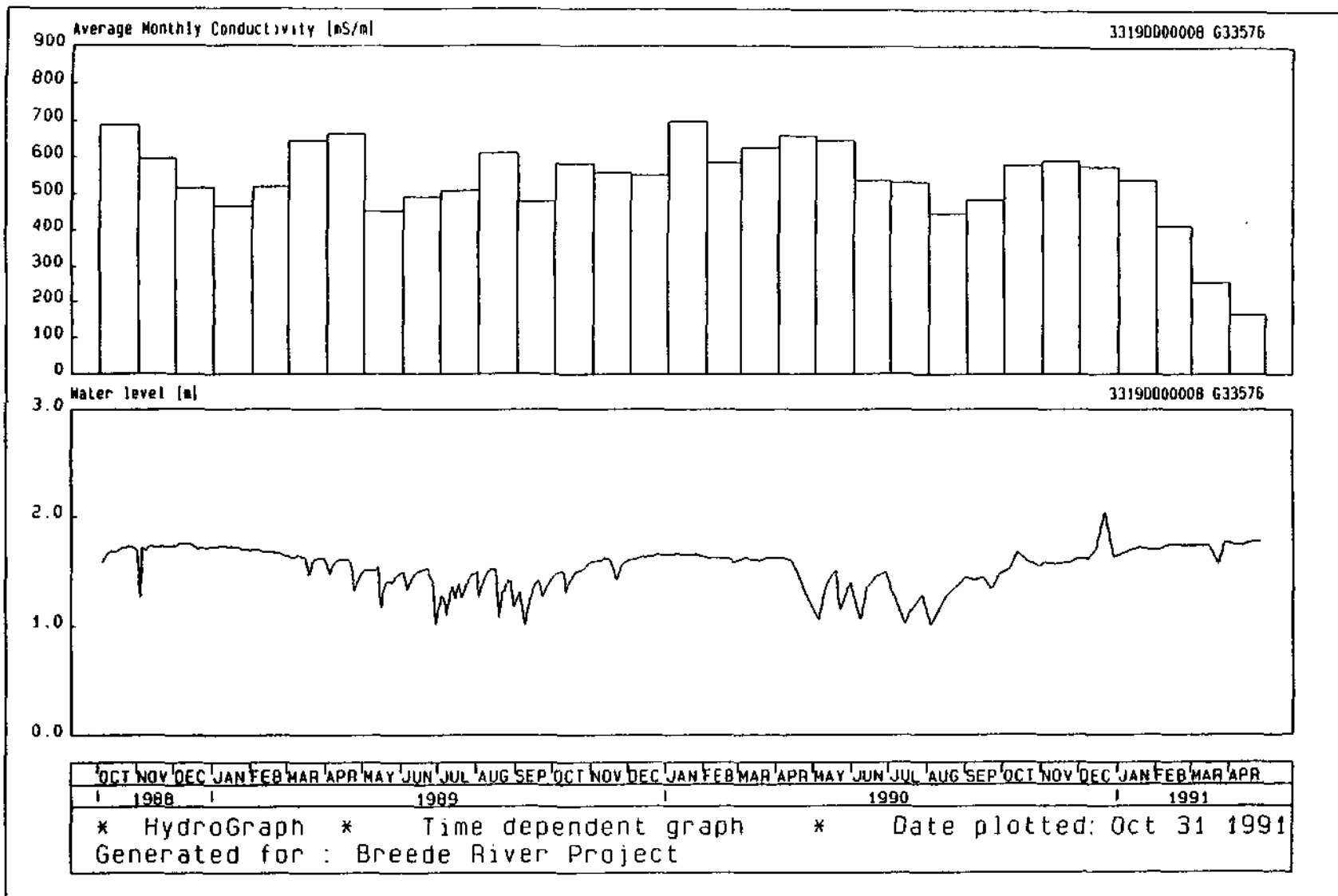

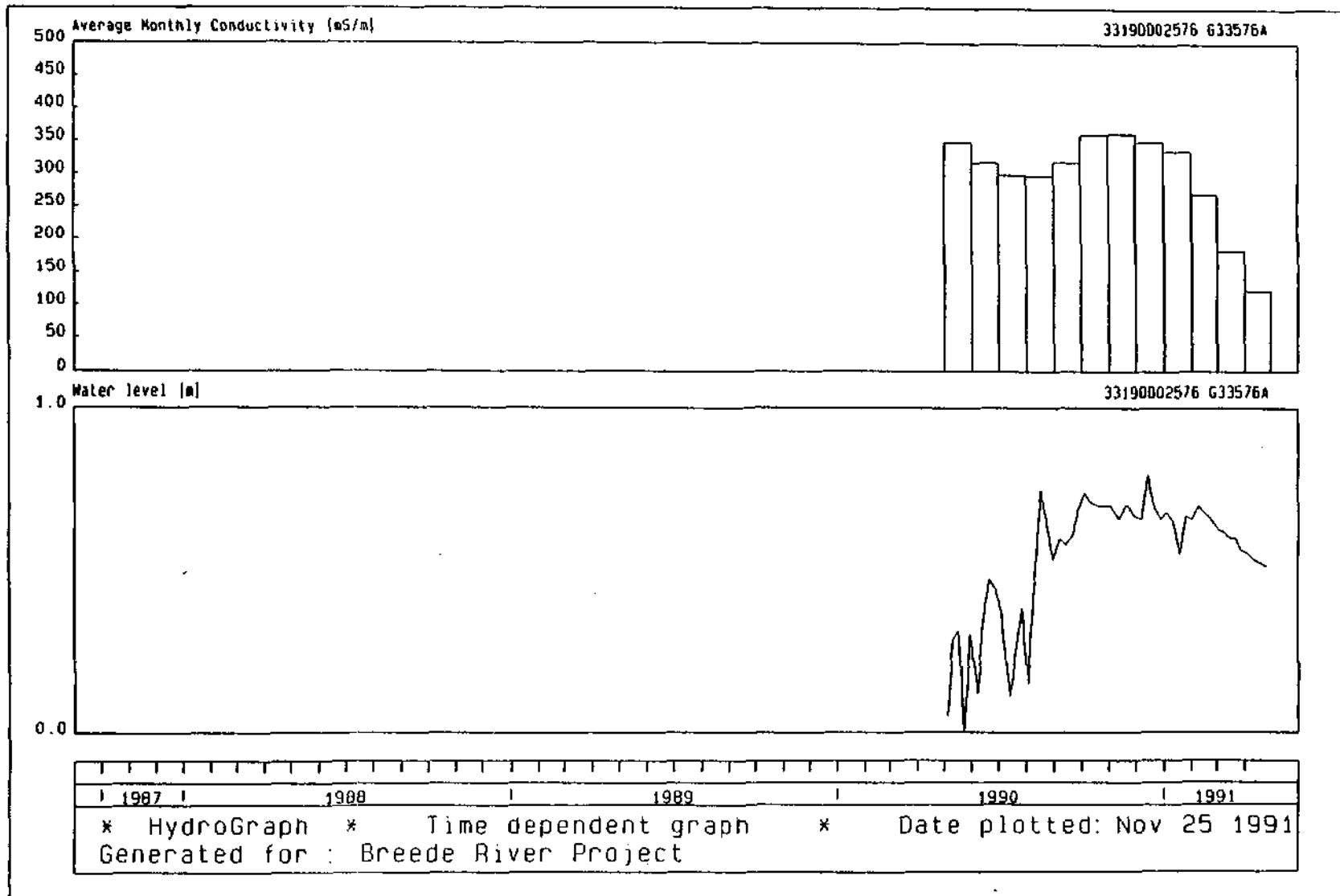

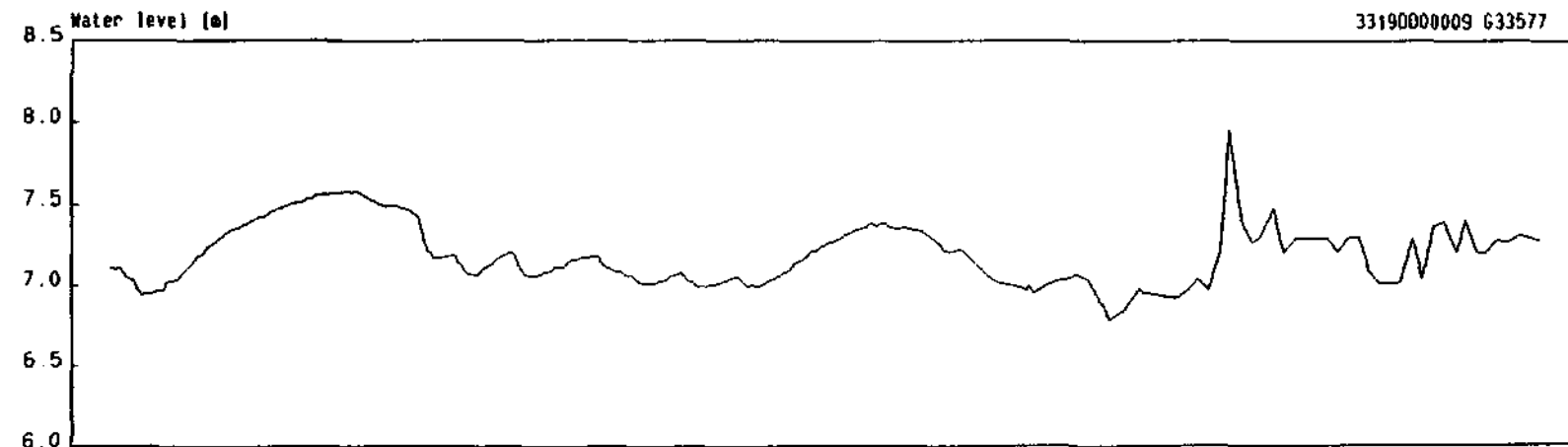
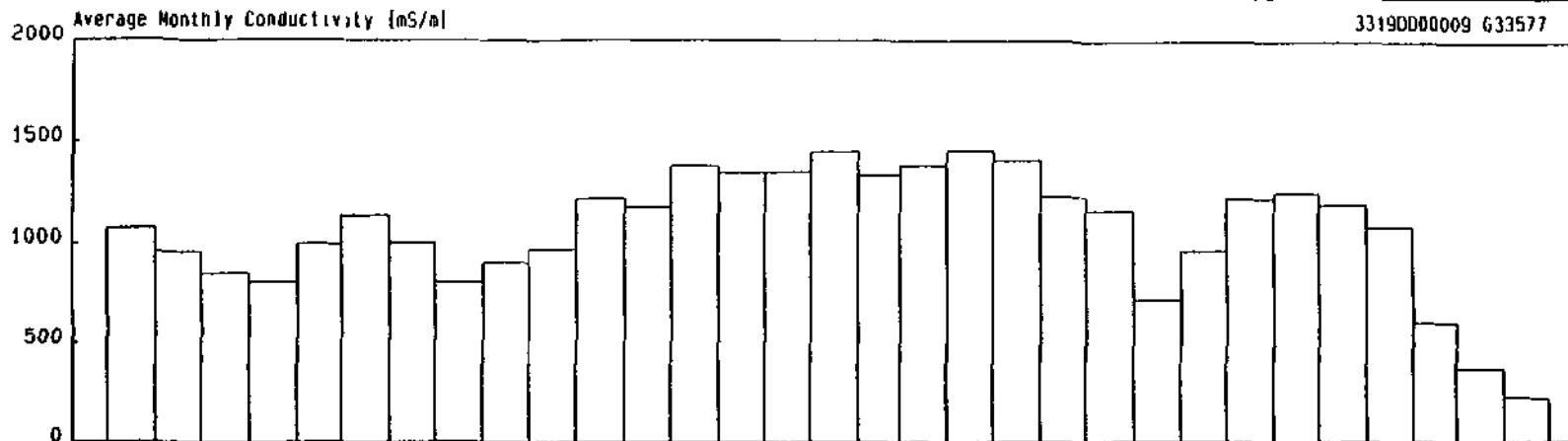

OCT	NOV	DEC	JAN	FEB	MAR	APR	MAY	JUN	JUL	AUG	SEP	OCT	NOV	DEC	JAN	FEB	MAR	APR	MAY	JUN	JUL	AUG	SEP	OCT	NOV	DEC	JAN	FEB	MAR	APR	
1988				1989								1990				1991															

* HydroGraph * Time dependent graph * Date plotted: Nov 01 1991
 Generated for : Breede River Project

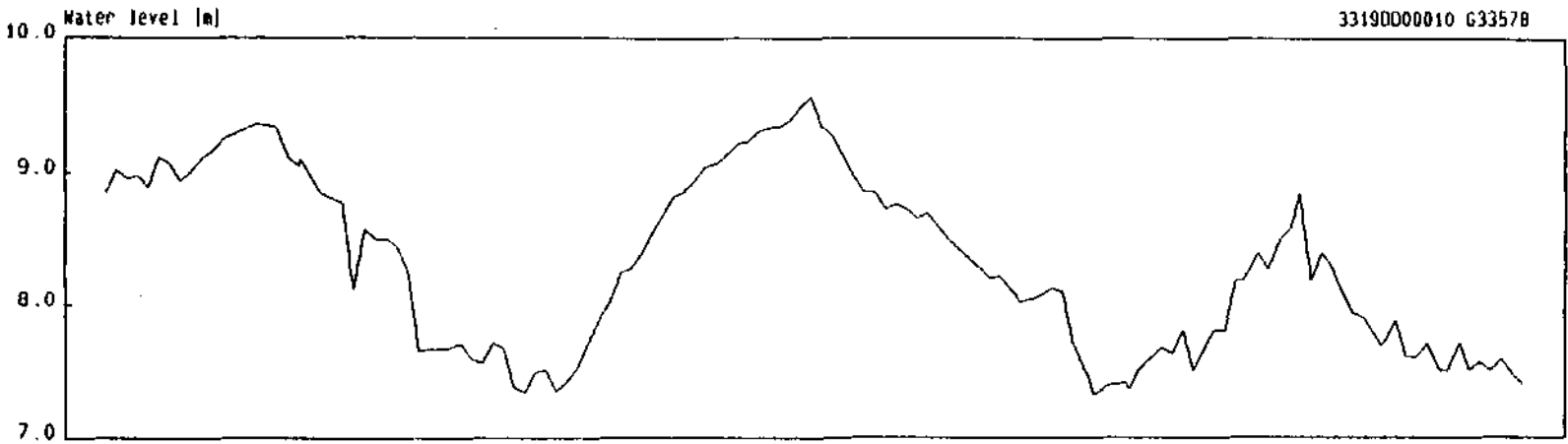
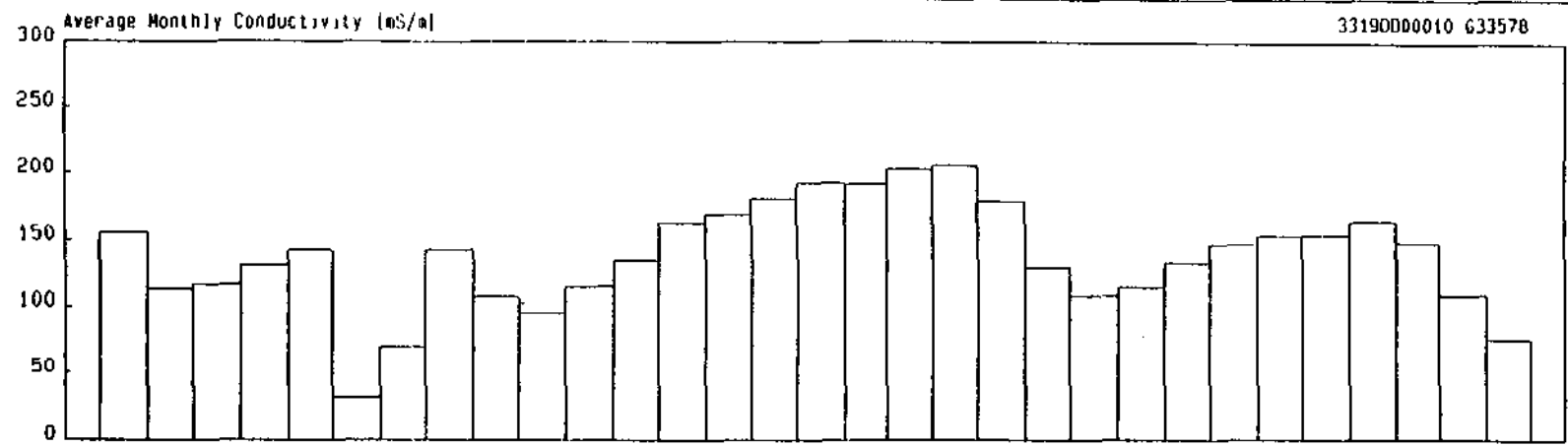

OCT	NOV	DEC	JAN	FEB	MAR	APR	MAY	JUN	JUL	AUG	SEP	OCT	NOV	DEC	JAN	FEB	MAR	APR	MAY	JUN	JUL	AUG	SEP	OCT	NOV	DEC	JAN	FEB	MAR	APR																	
1988								1989								1990								1991																							
* HydroGraph																* Time dependent graph																* Date plotted: Nov 01 1991															
Generated for : Breede River Project																																															

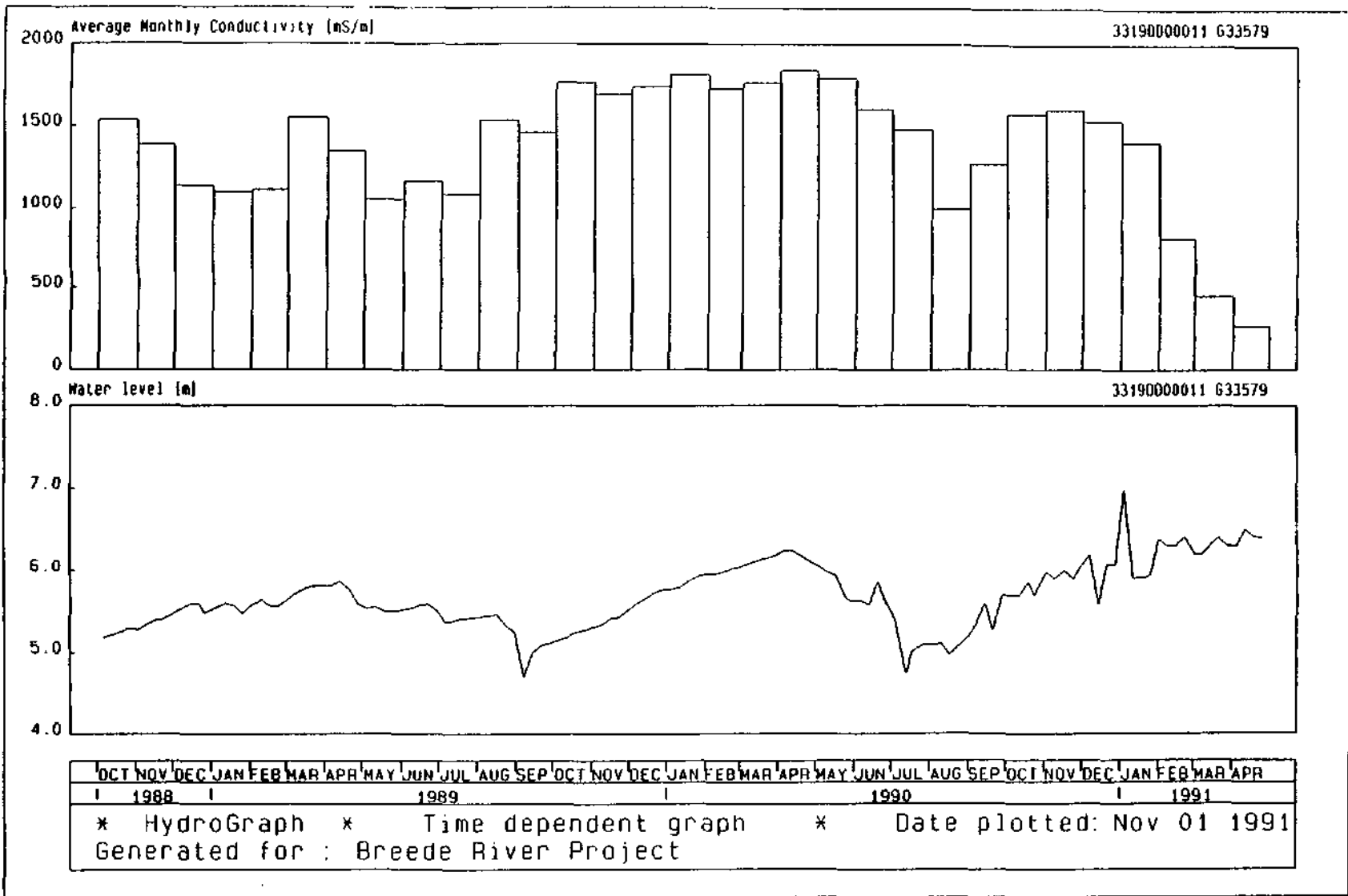

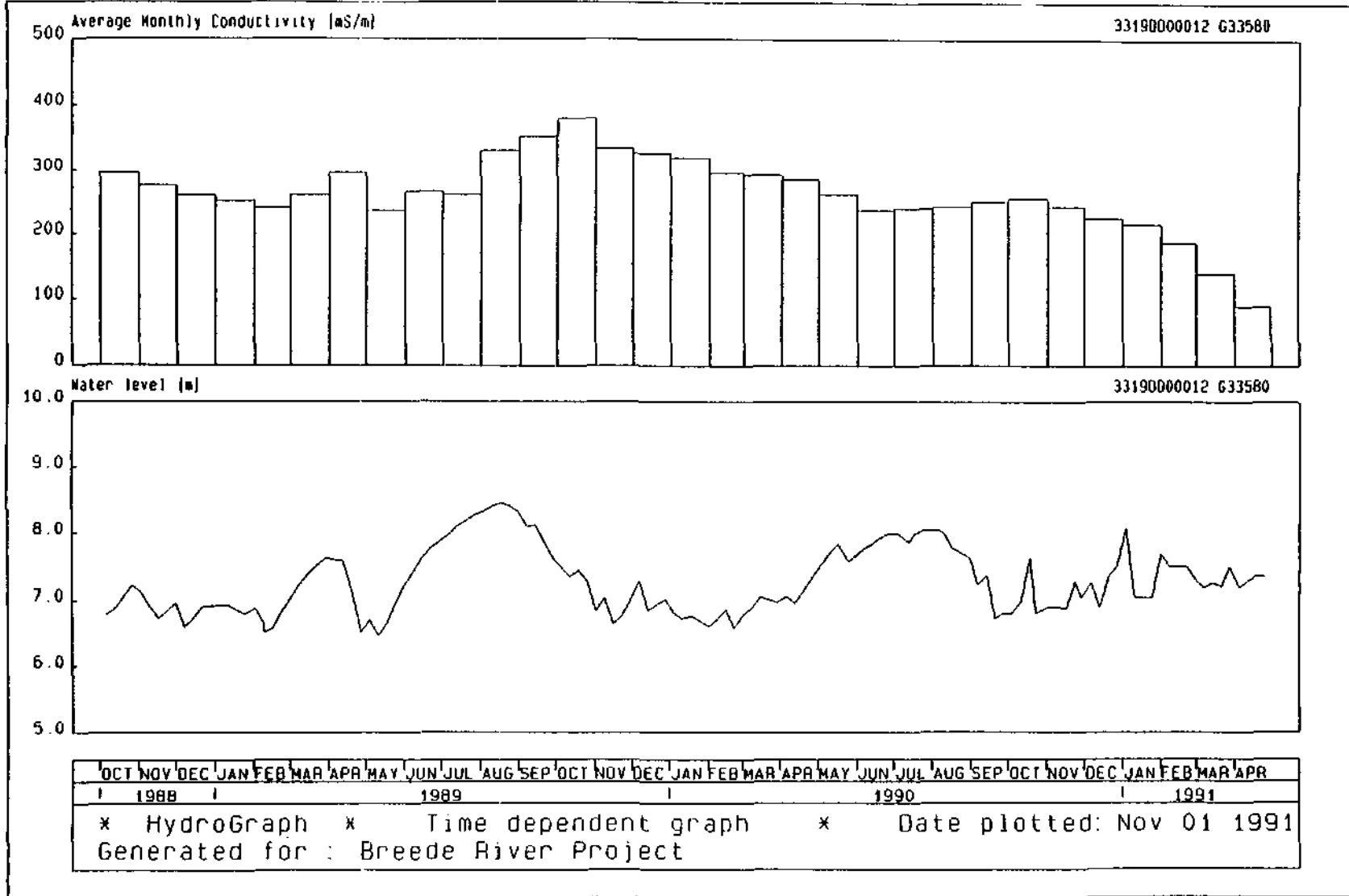

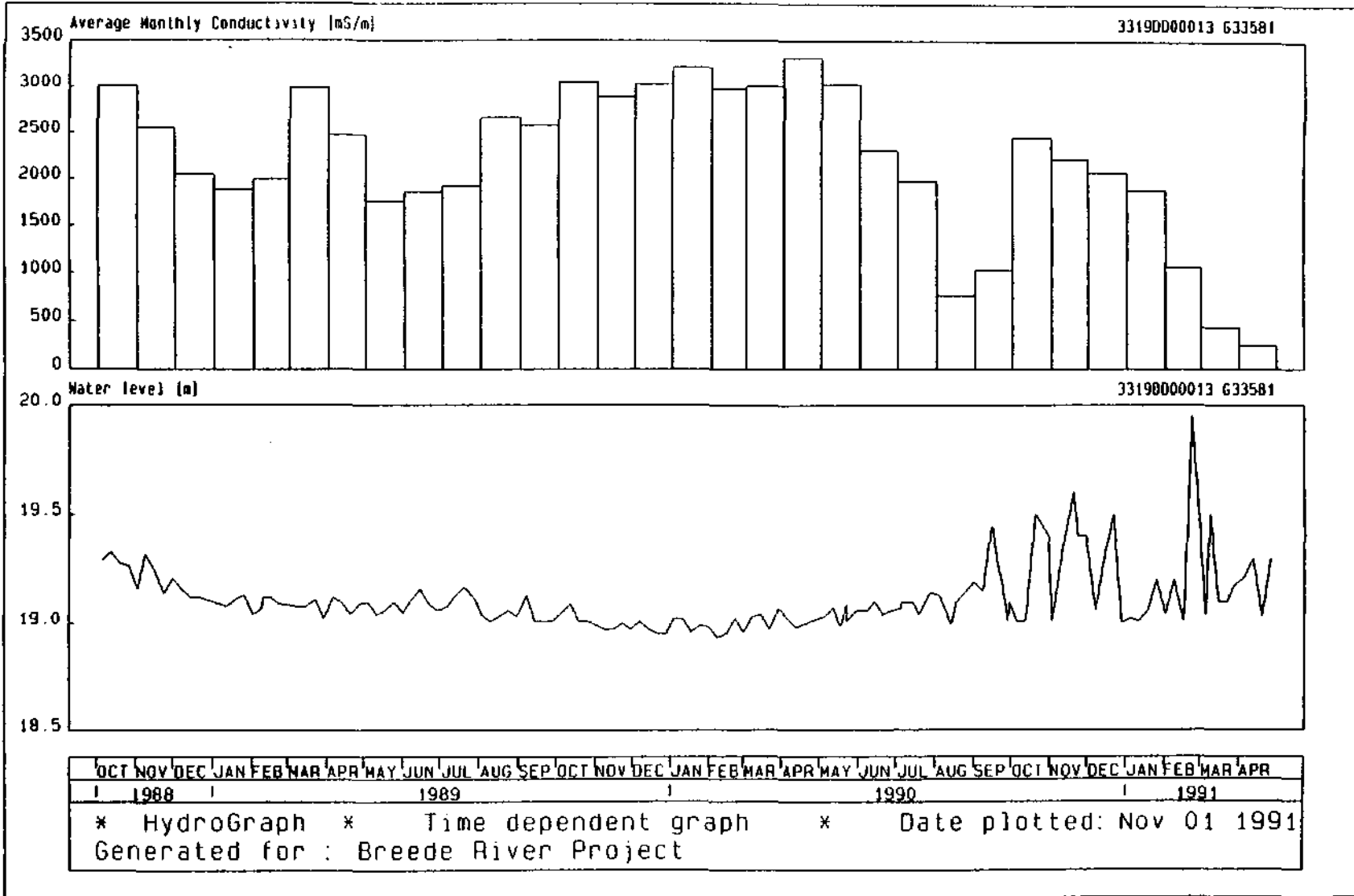

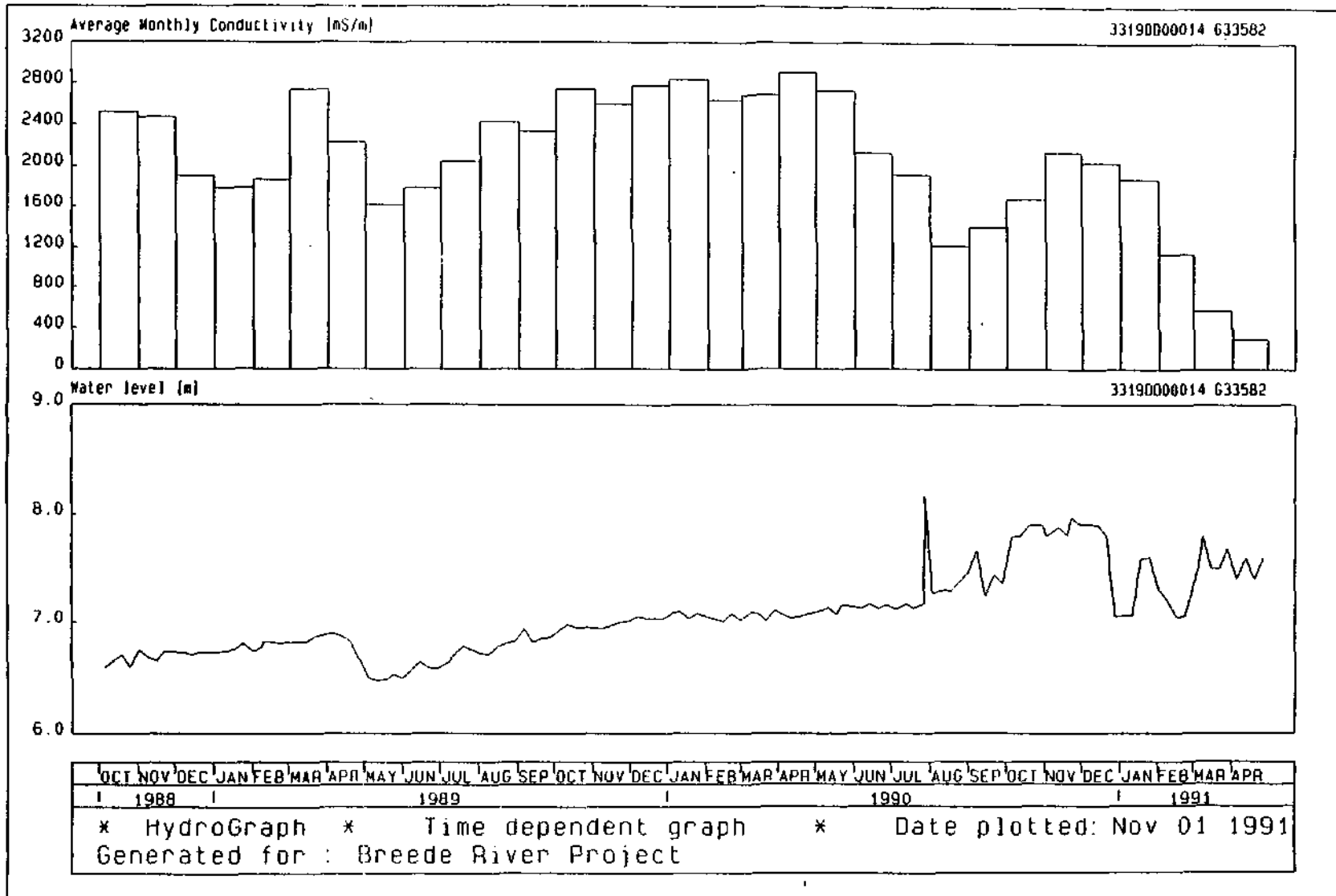

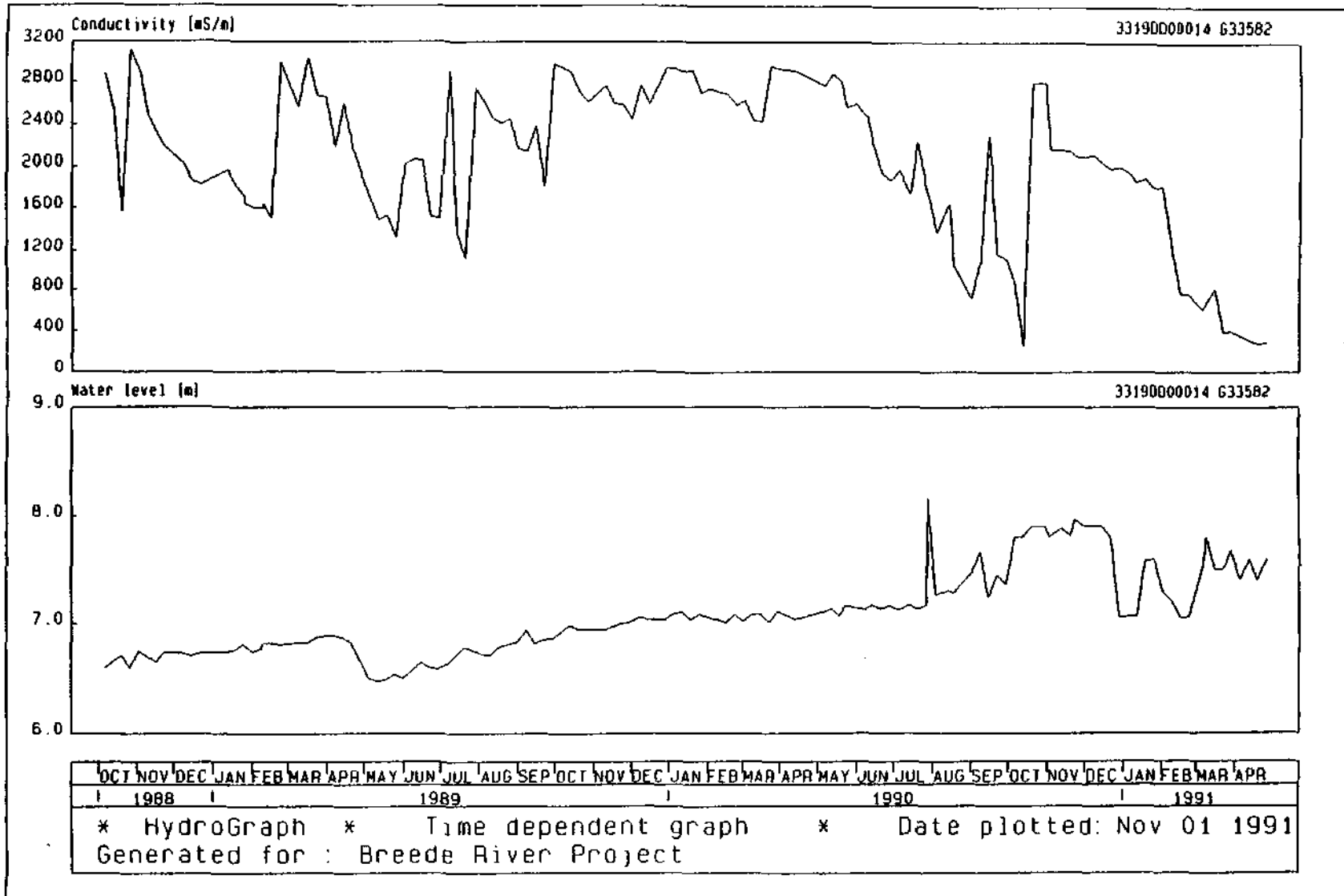

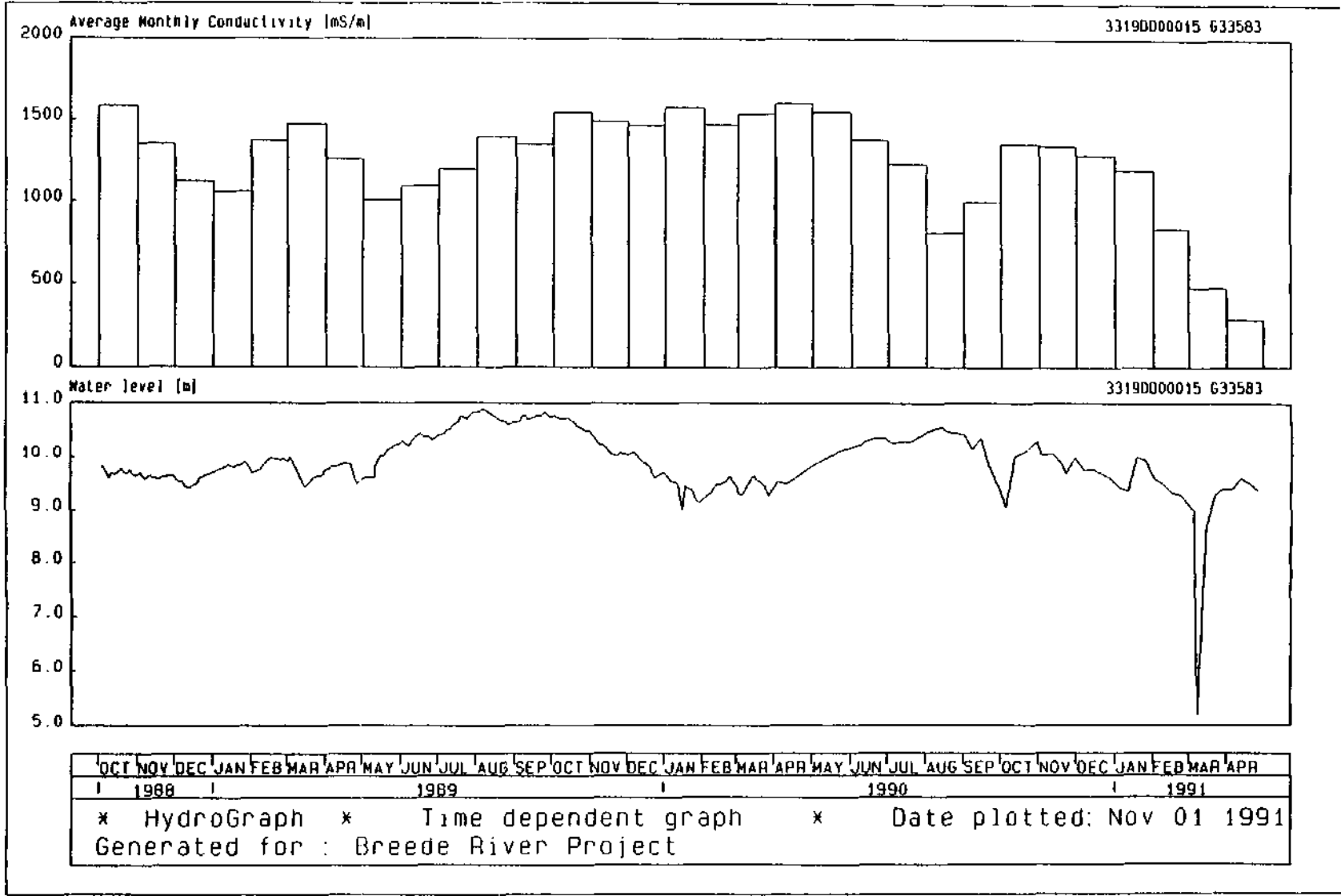

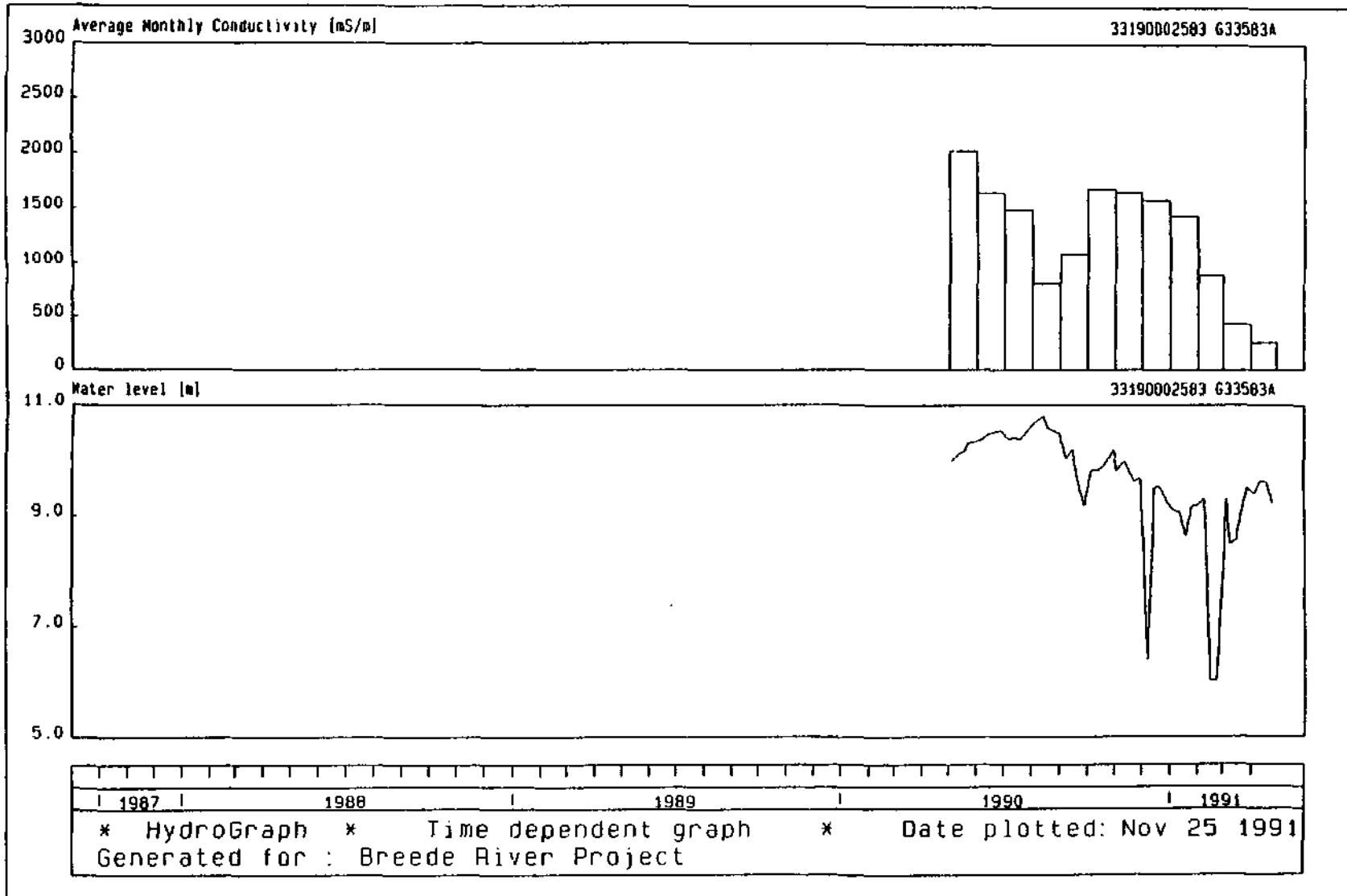

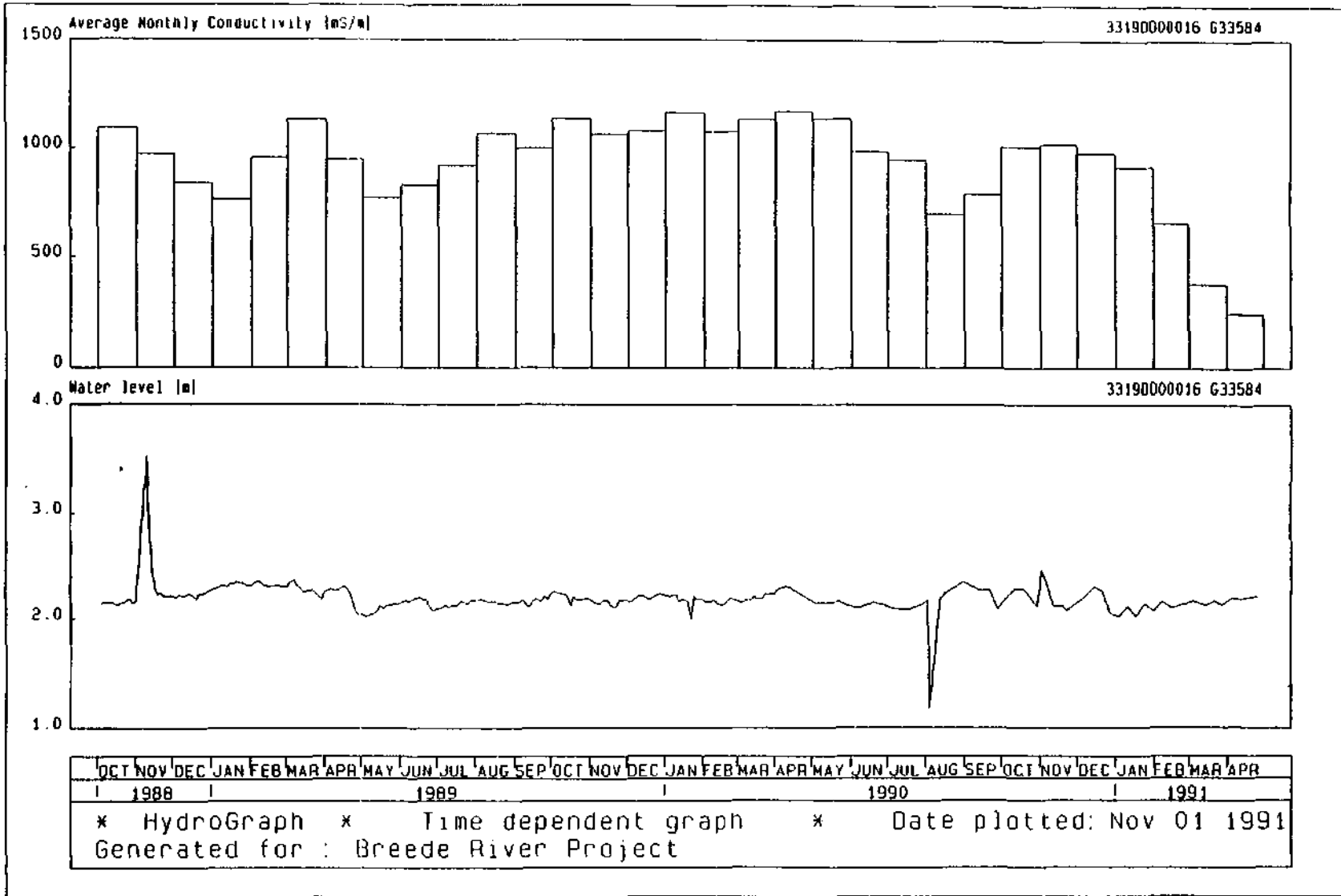

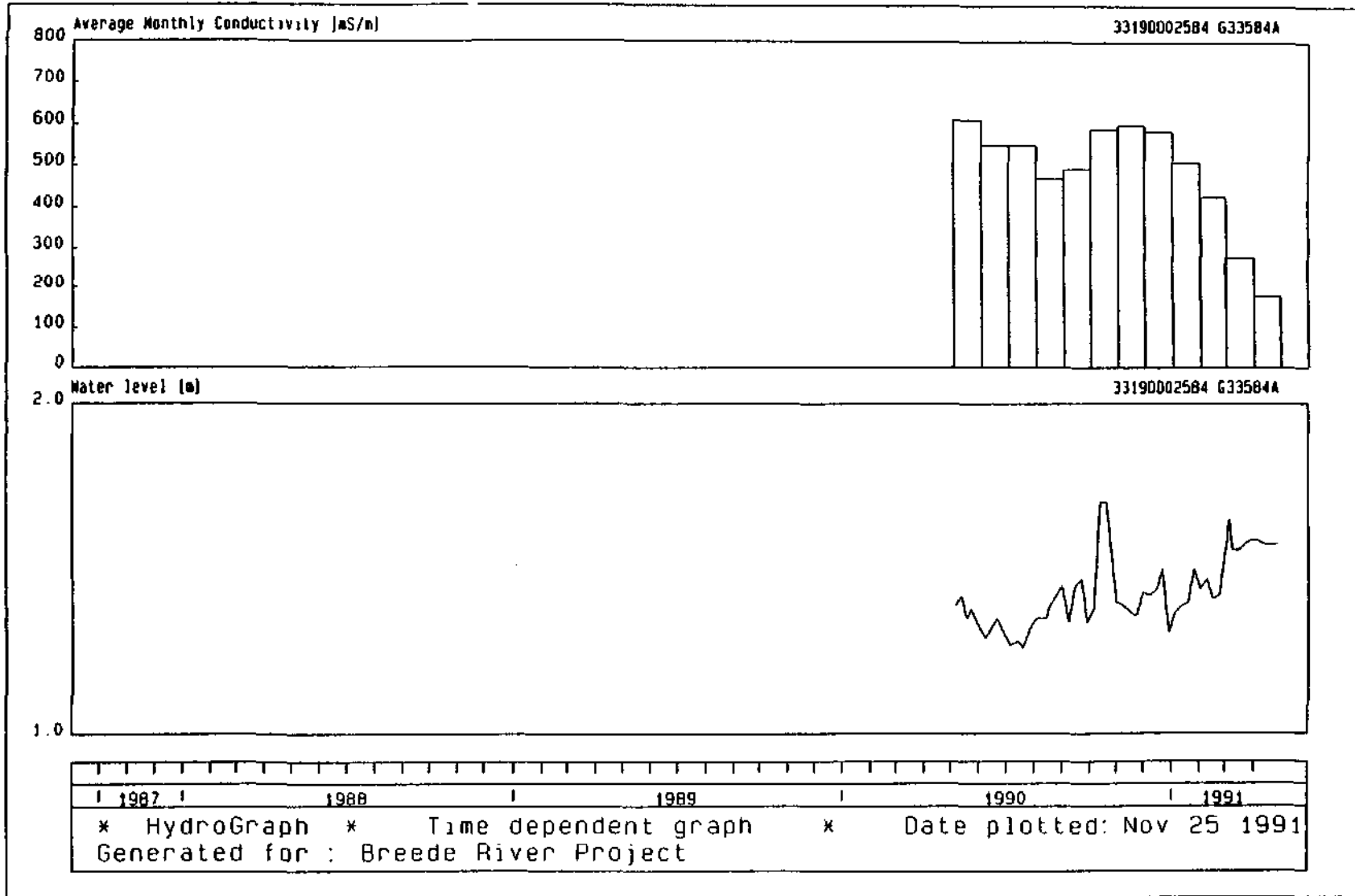

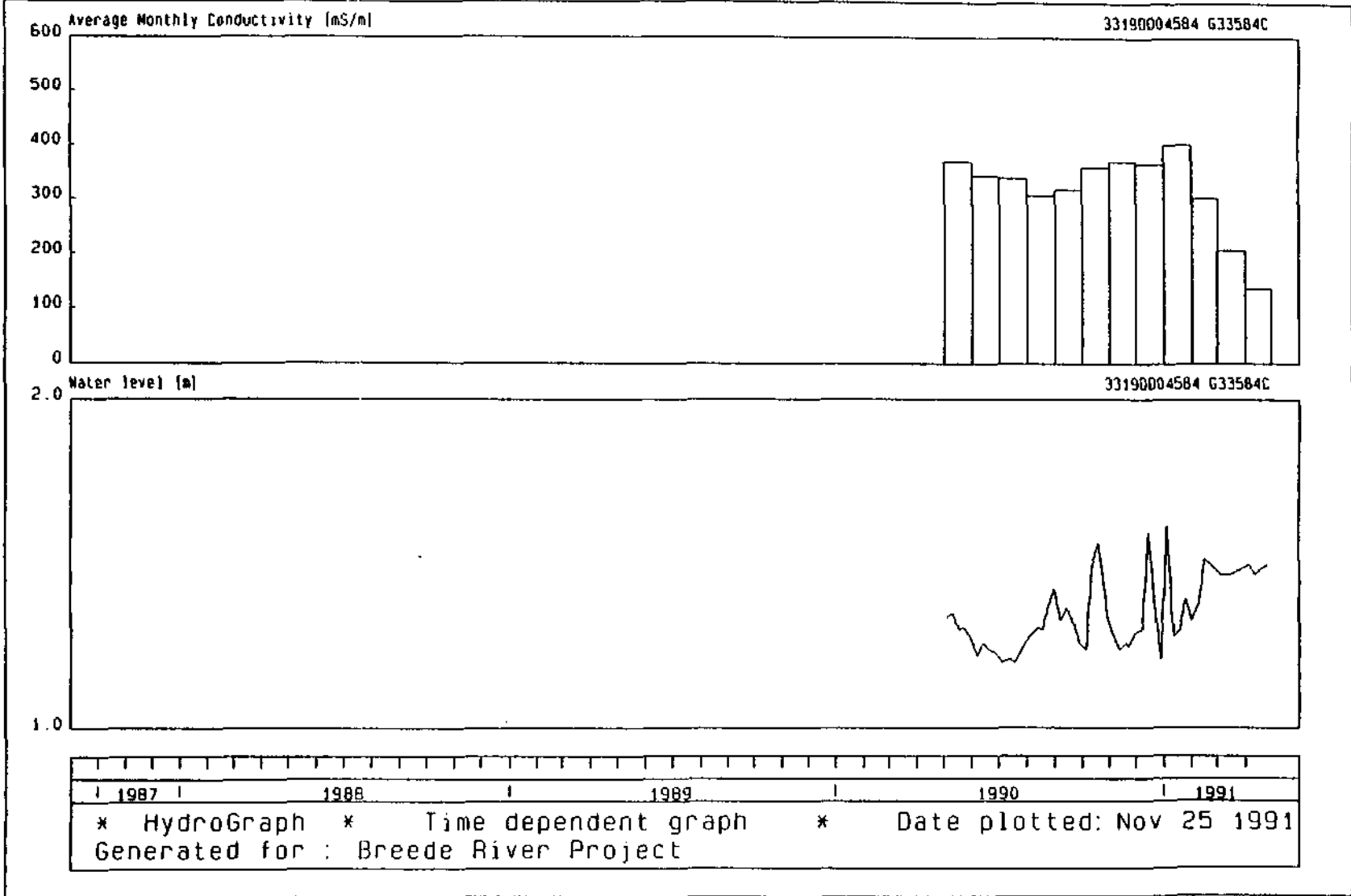

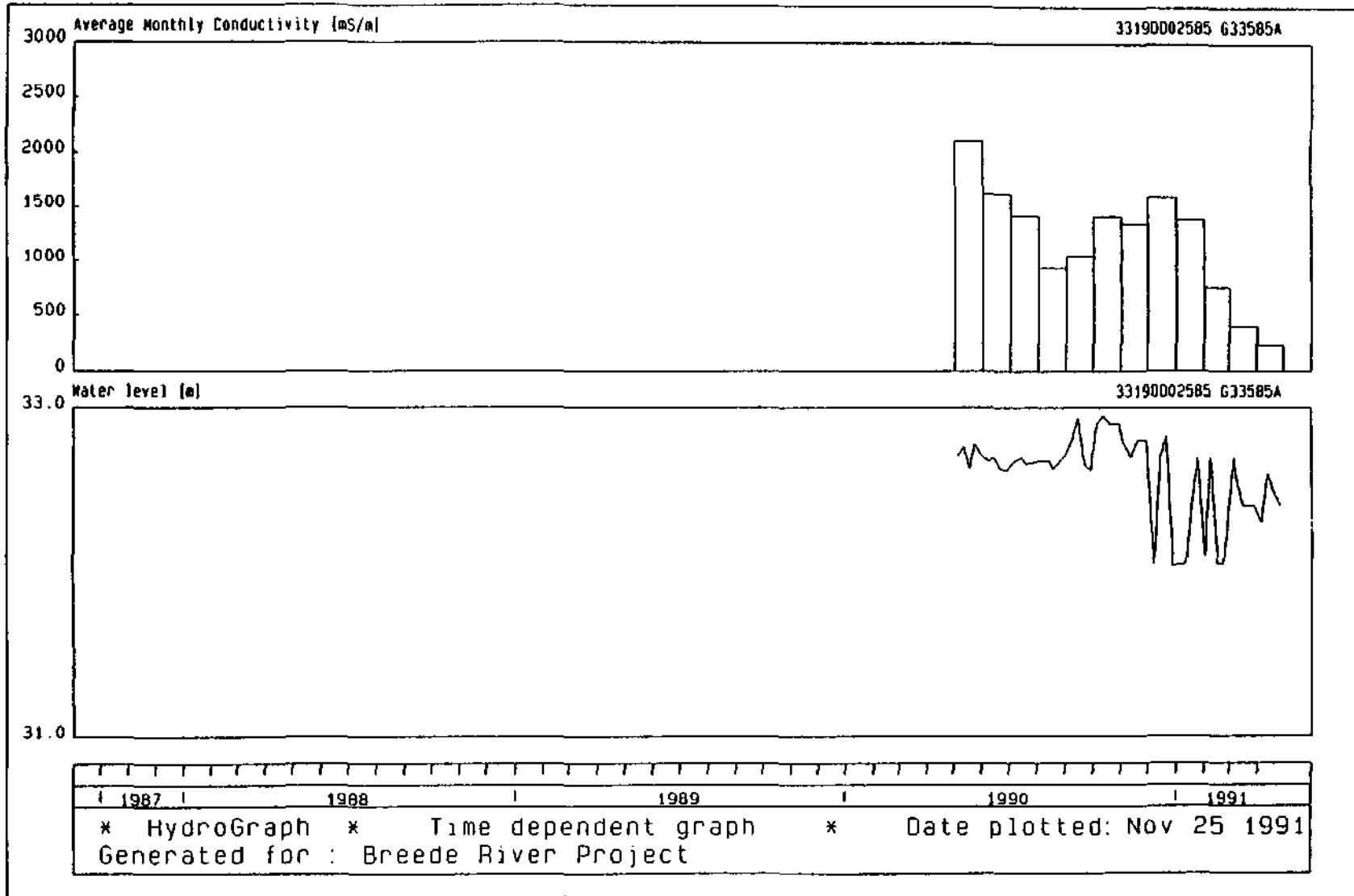

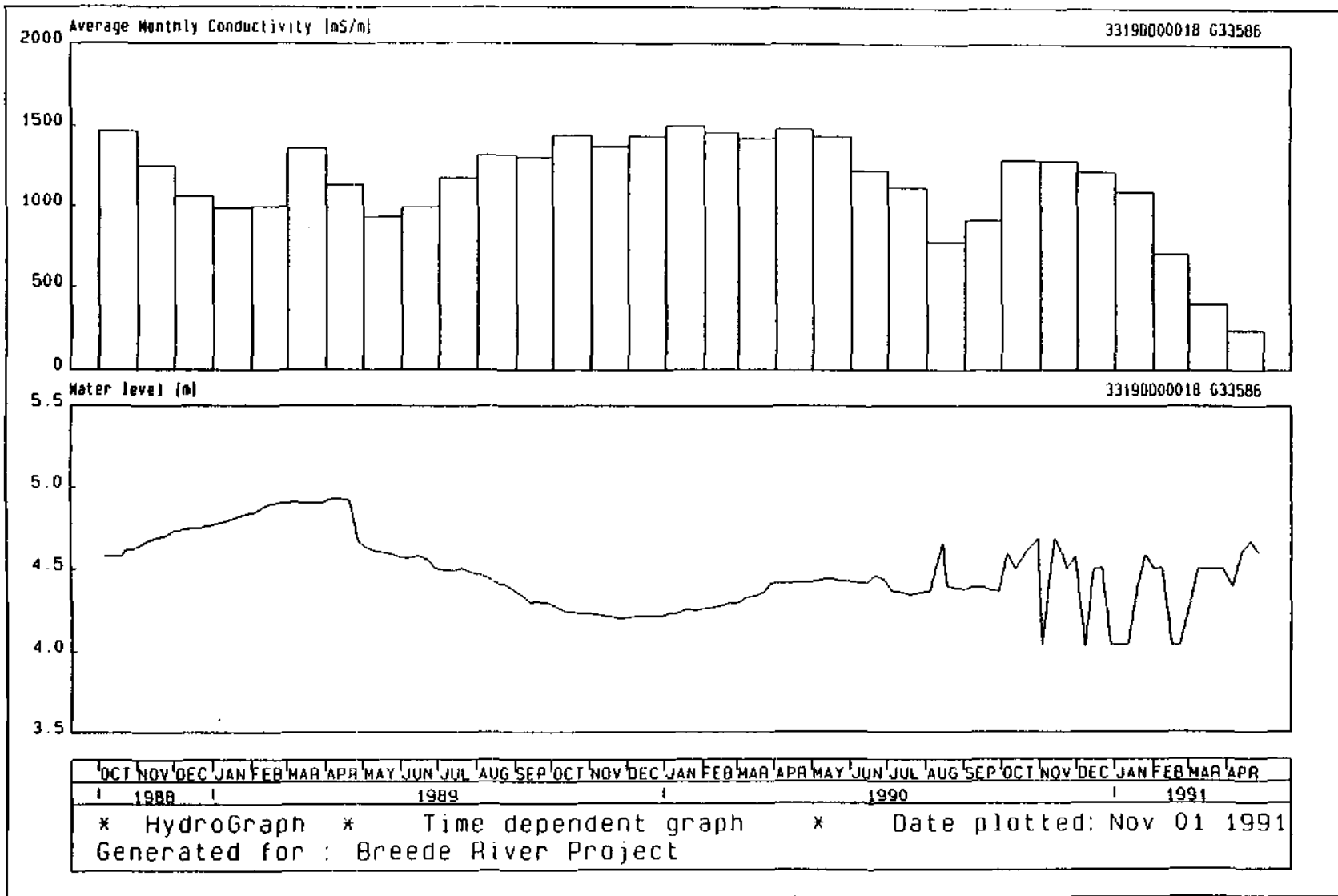

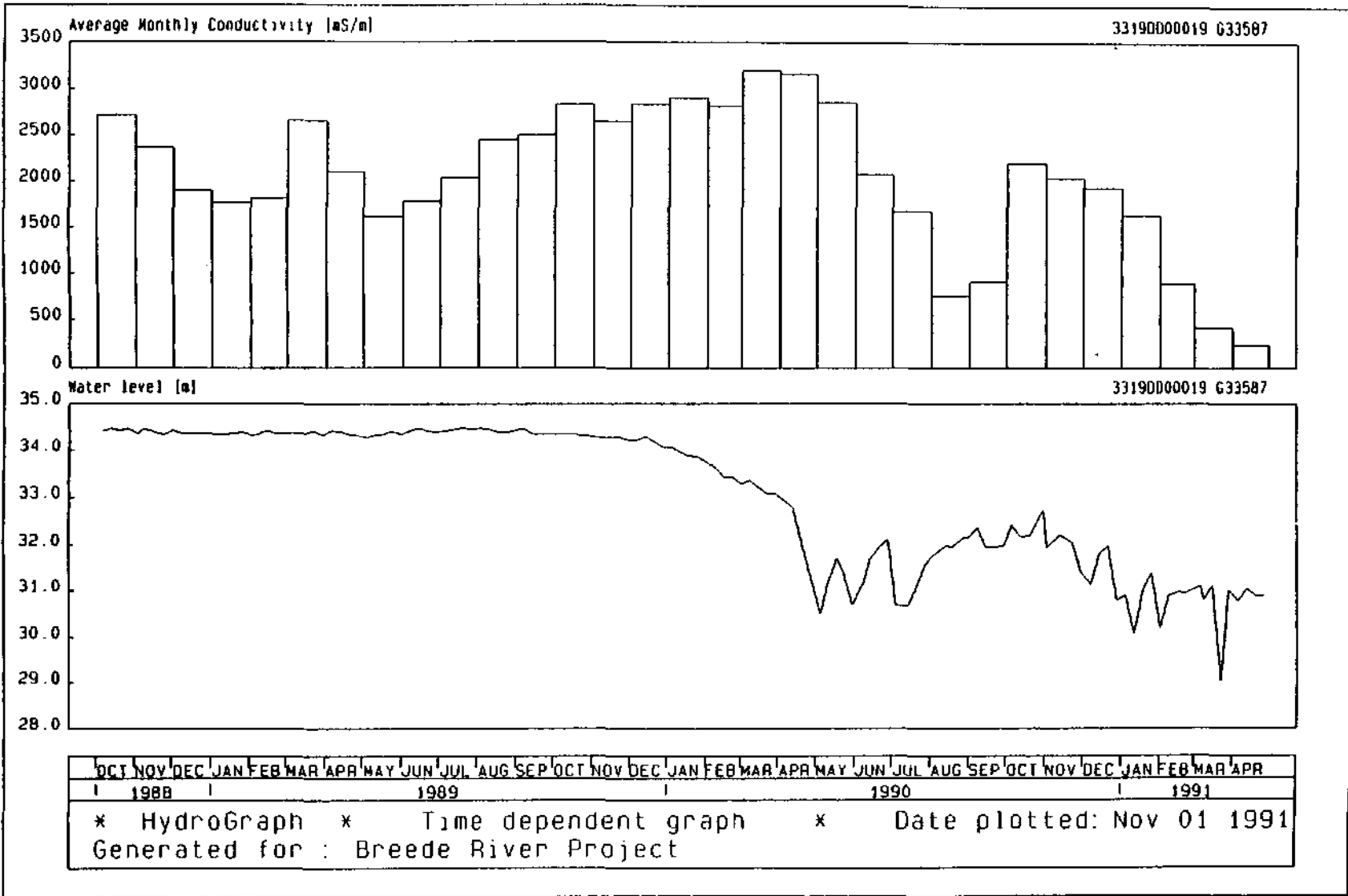

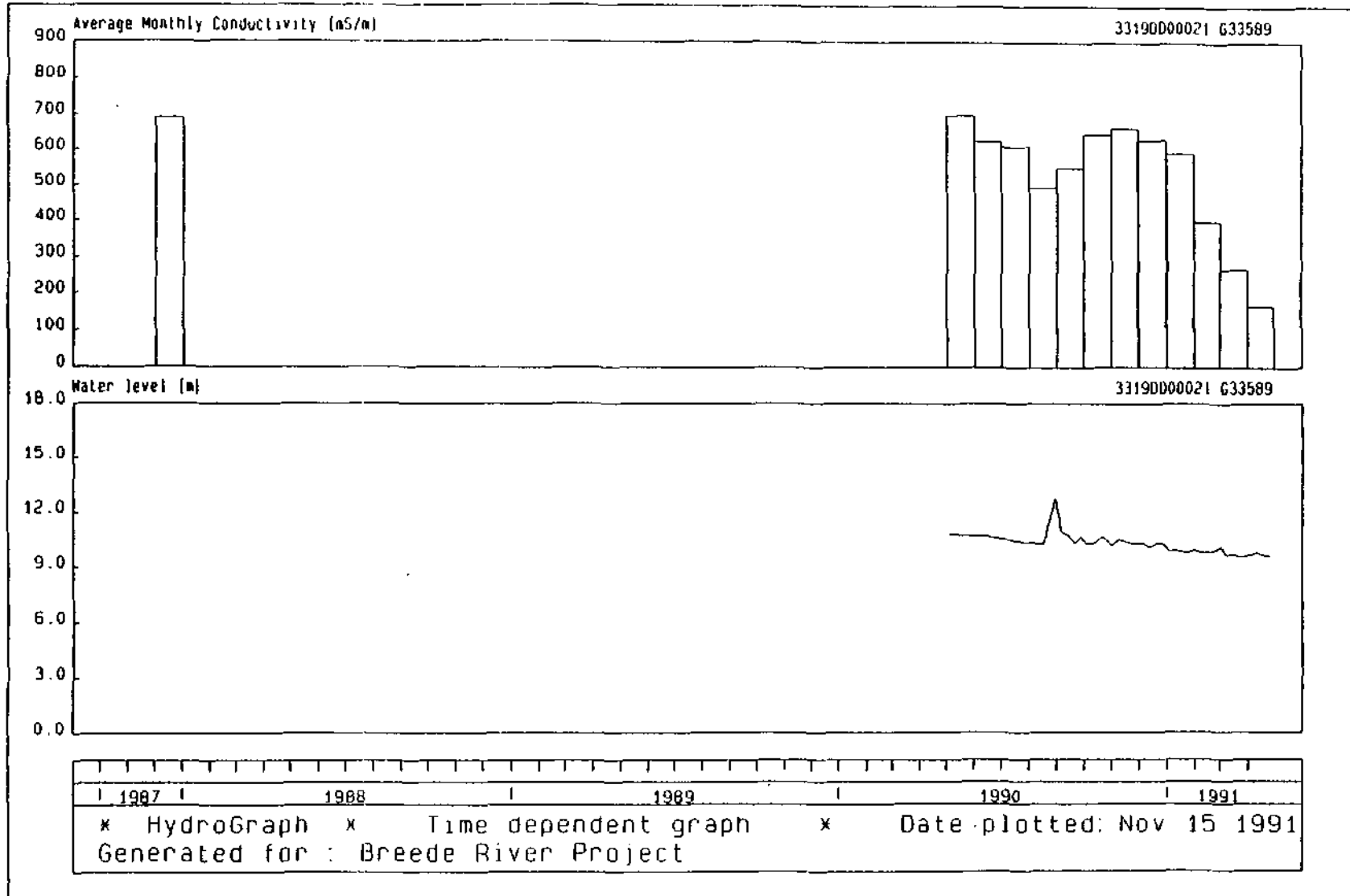

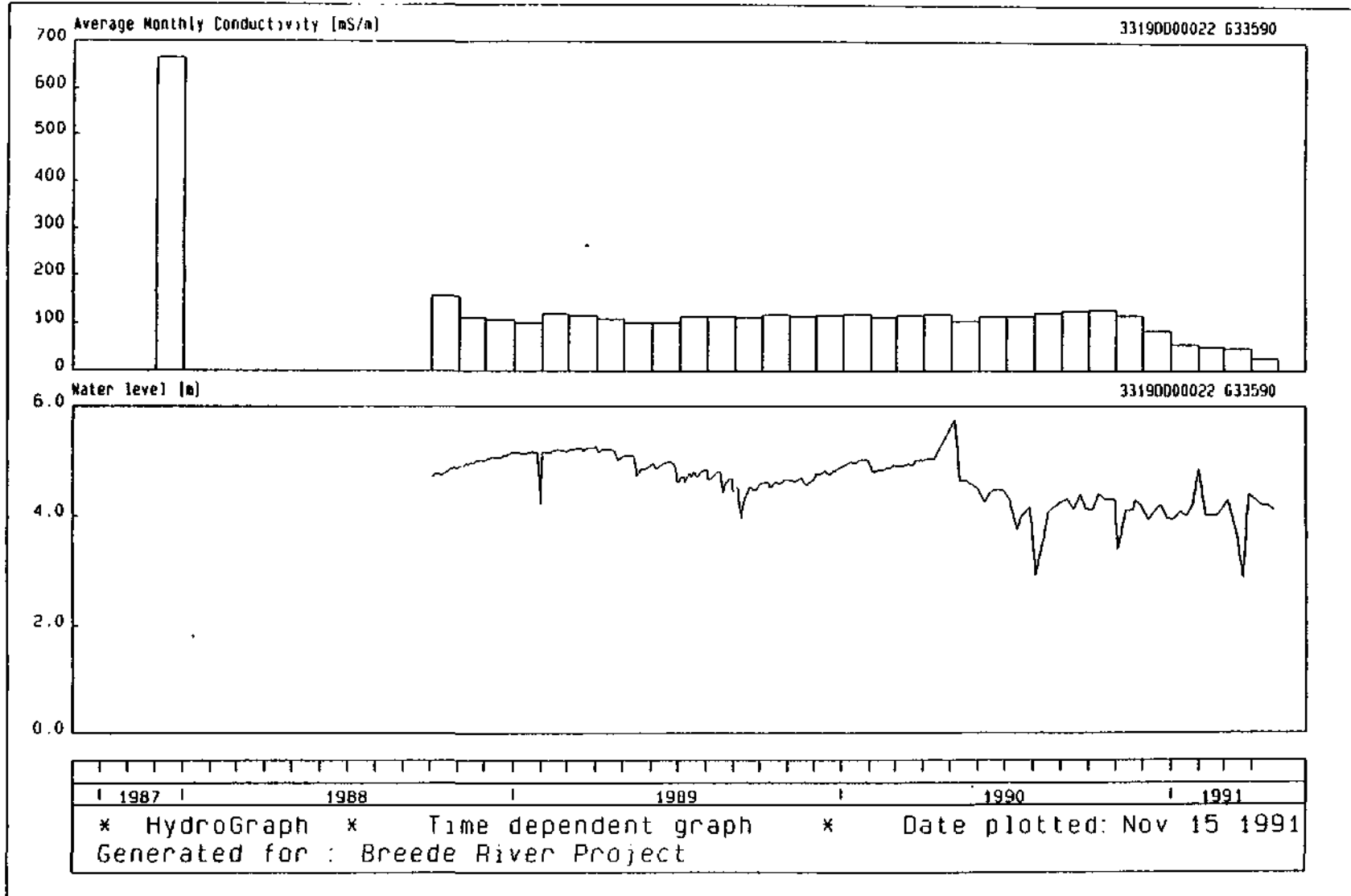

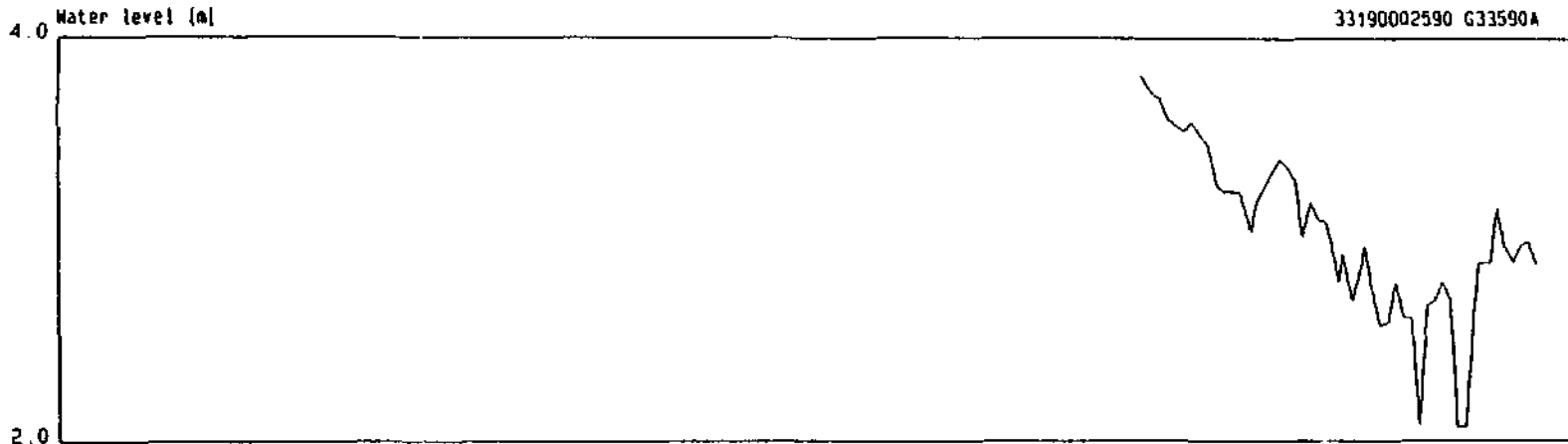
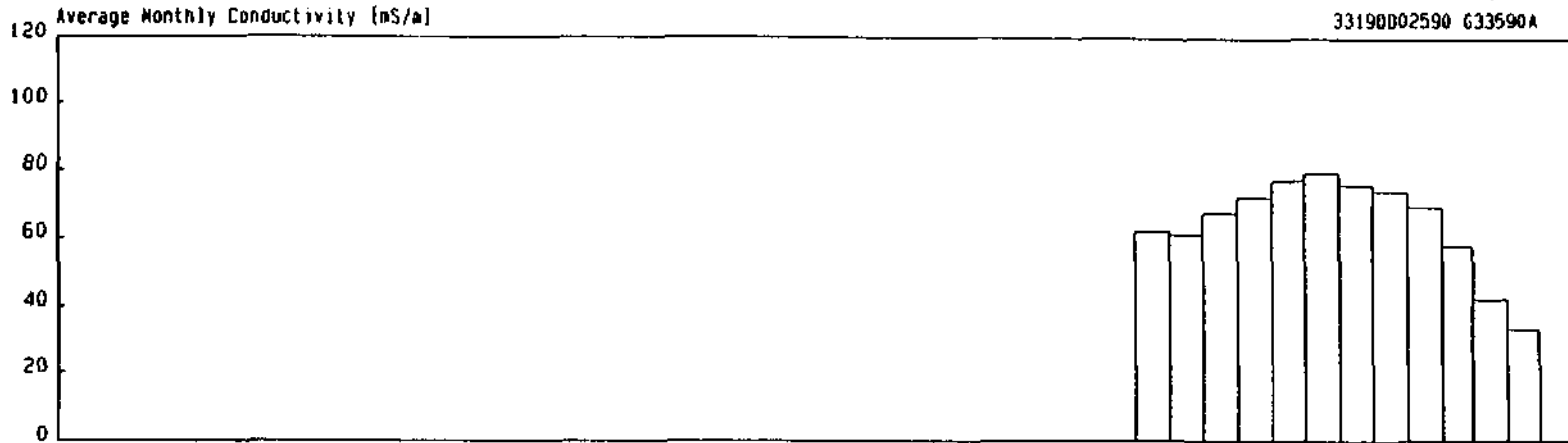

1987 1988 1989 1990 1991

* HydroGraph * Time dependent graph * Date plotted: Nov 25 1991
Generated for : Breede River Project

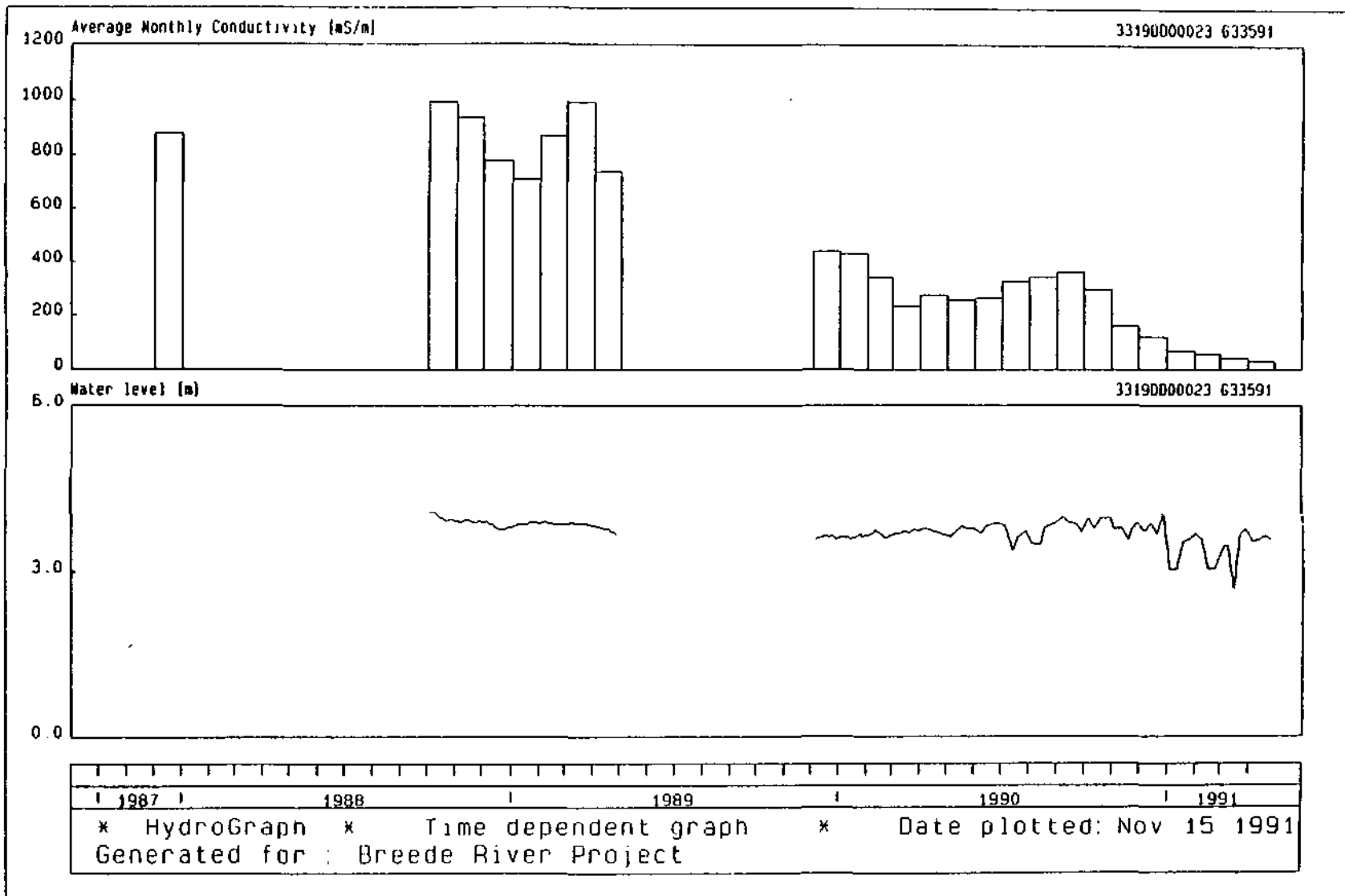

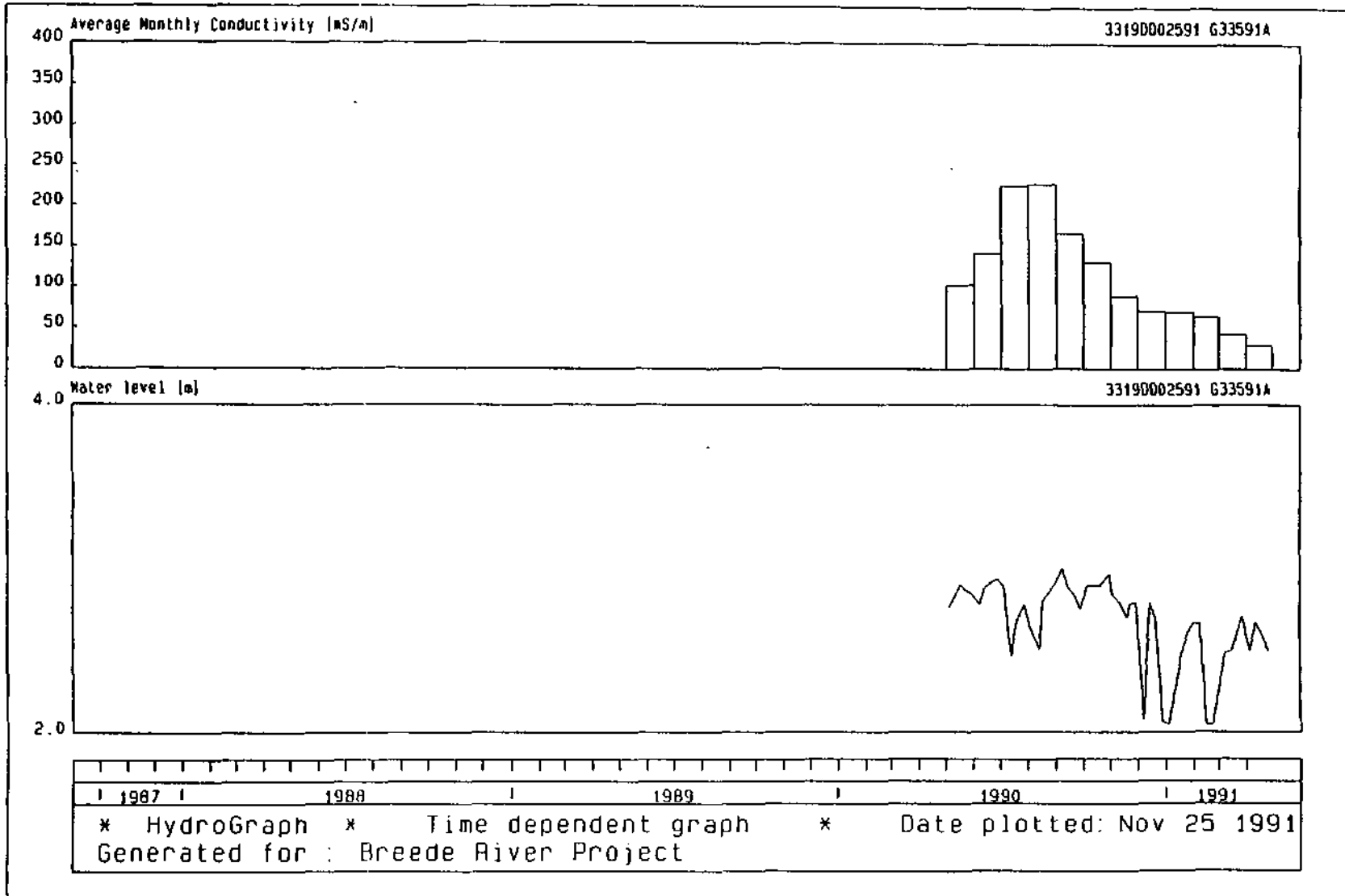

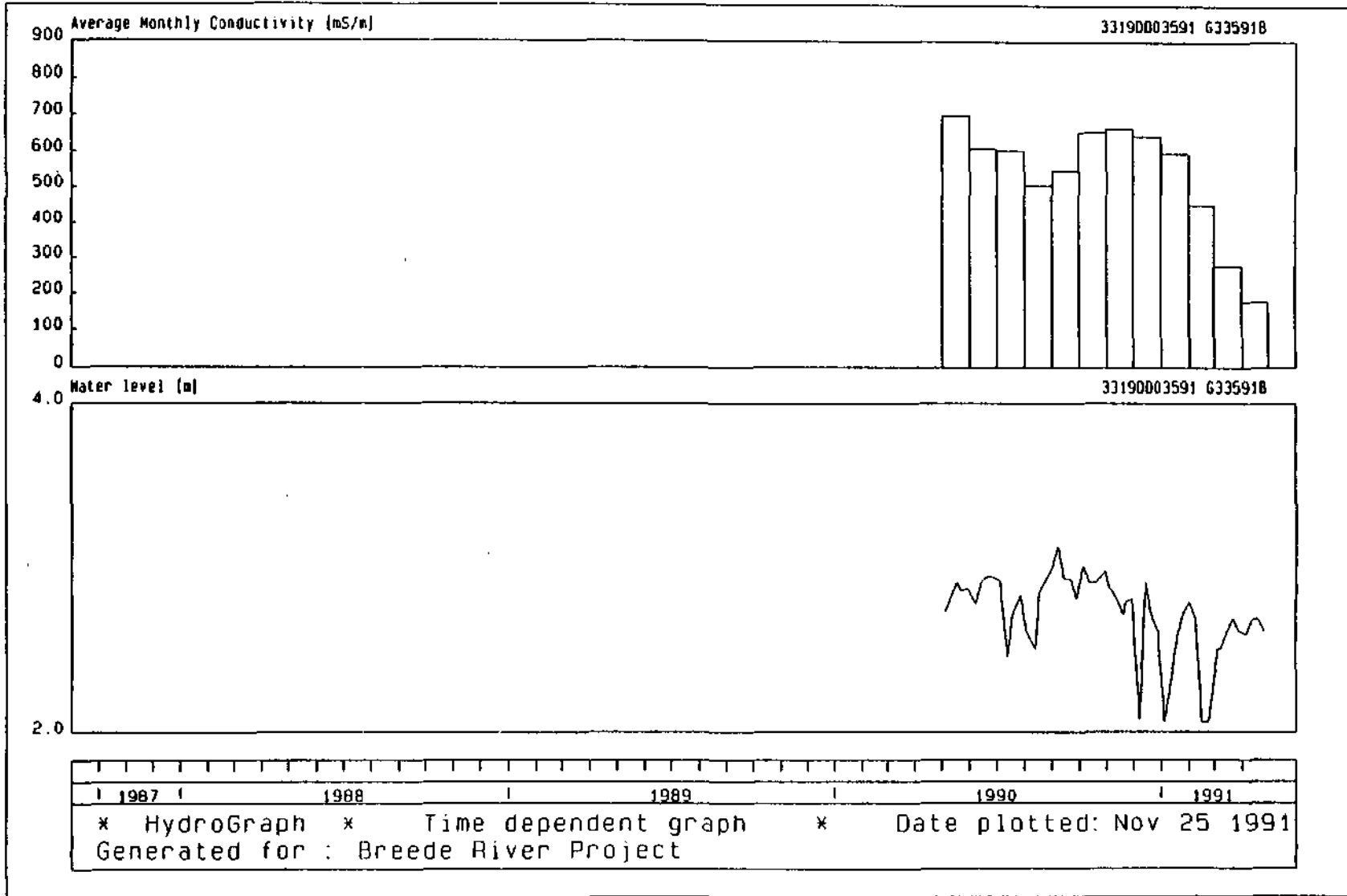

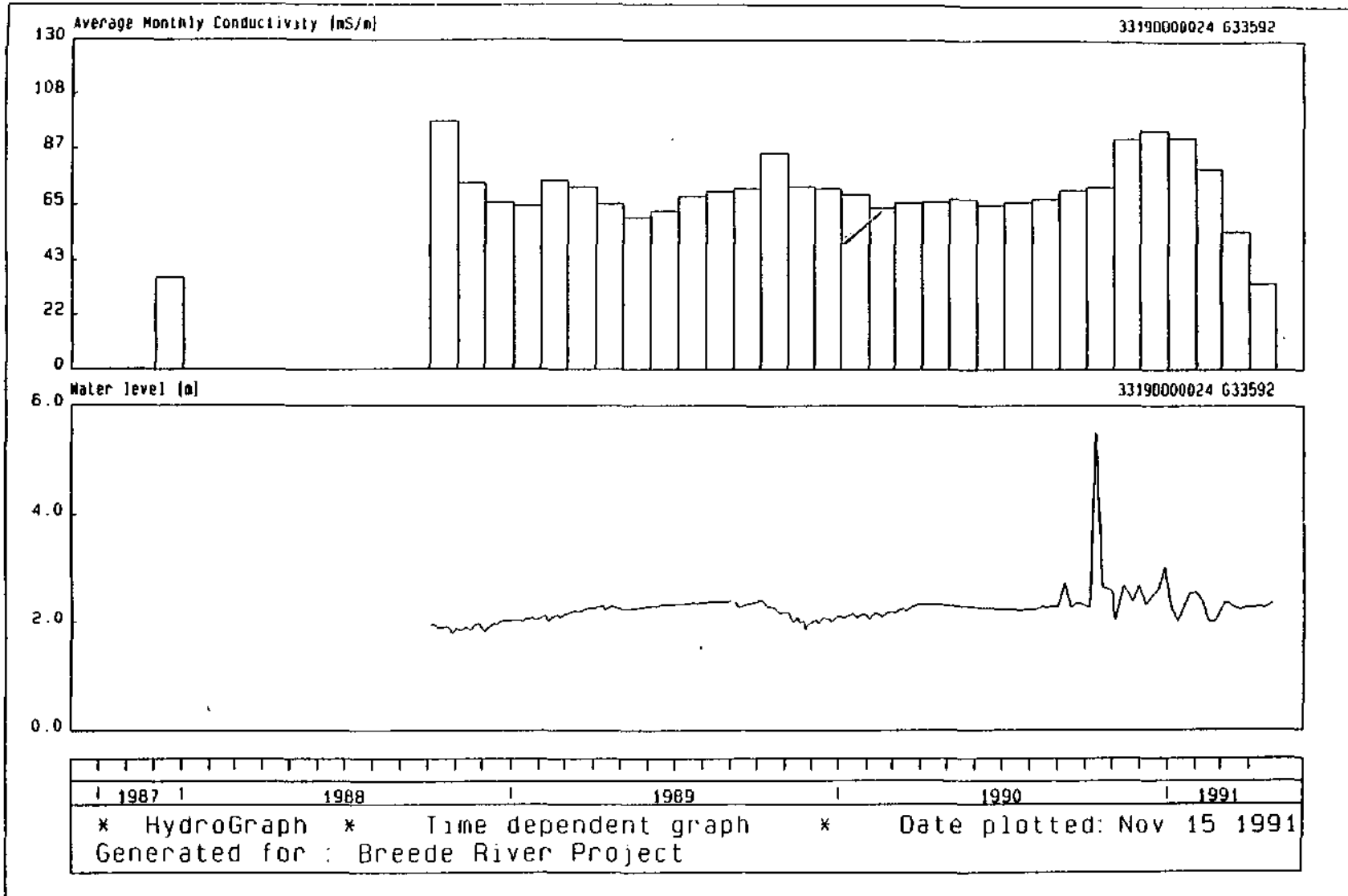

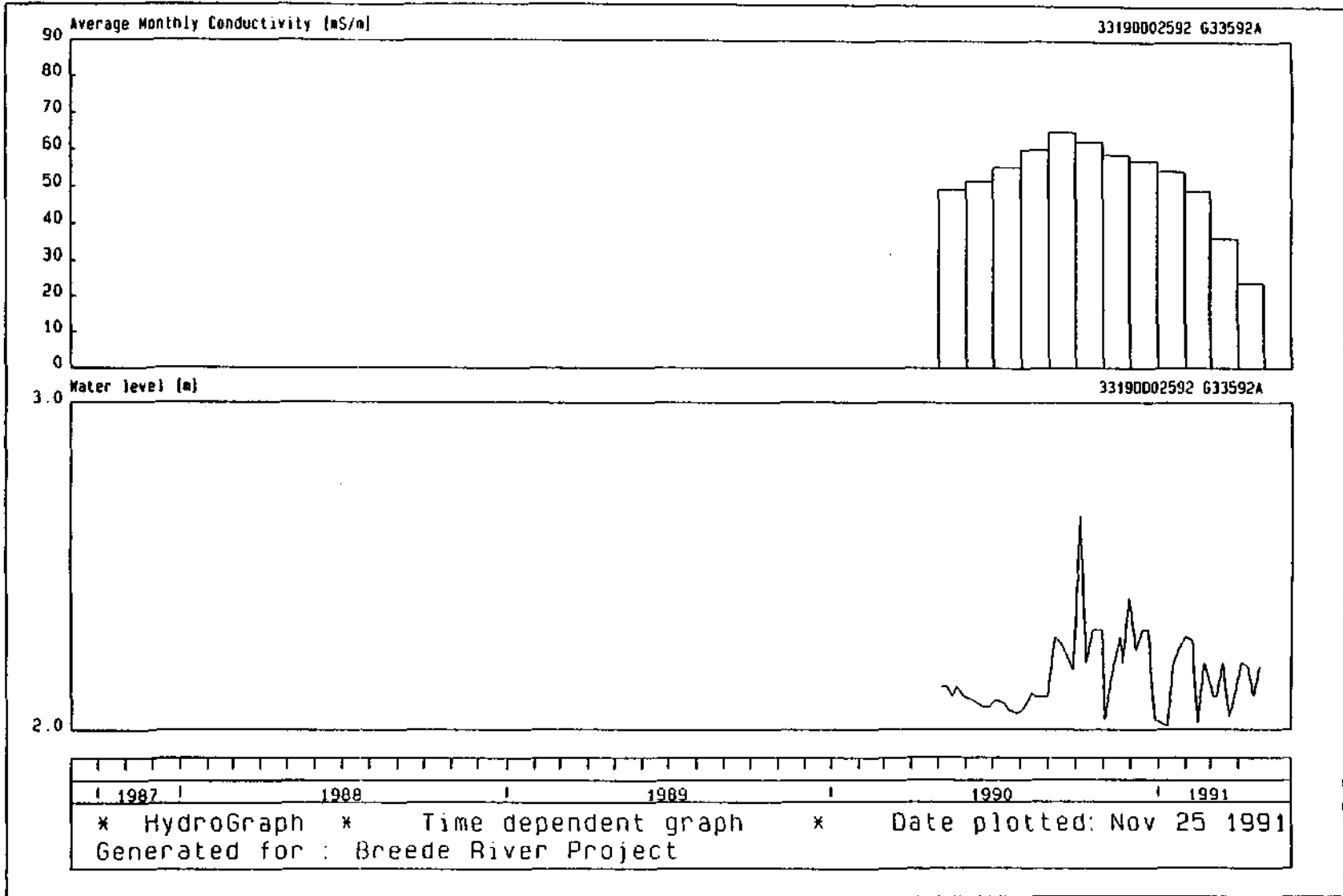

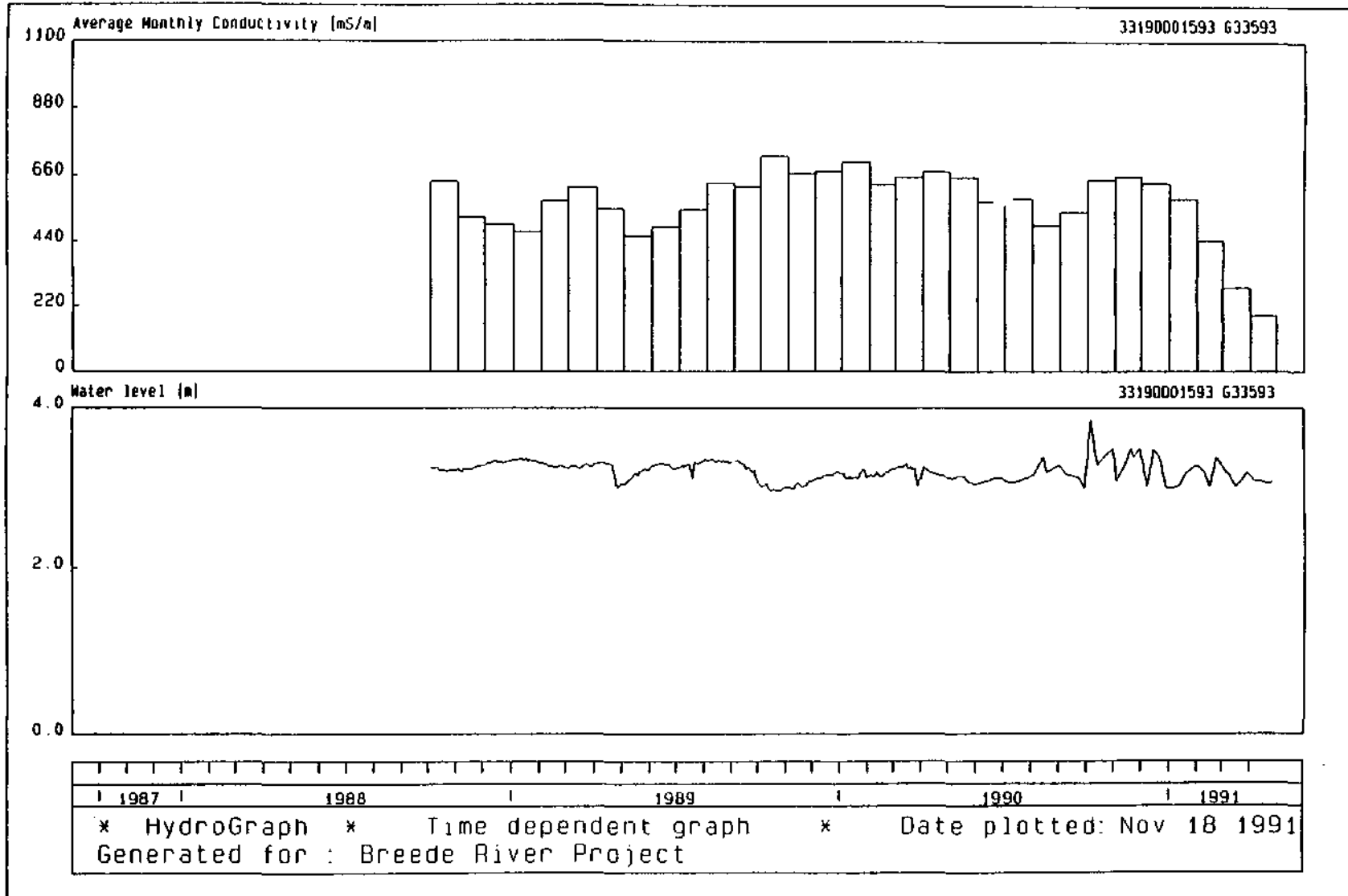

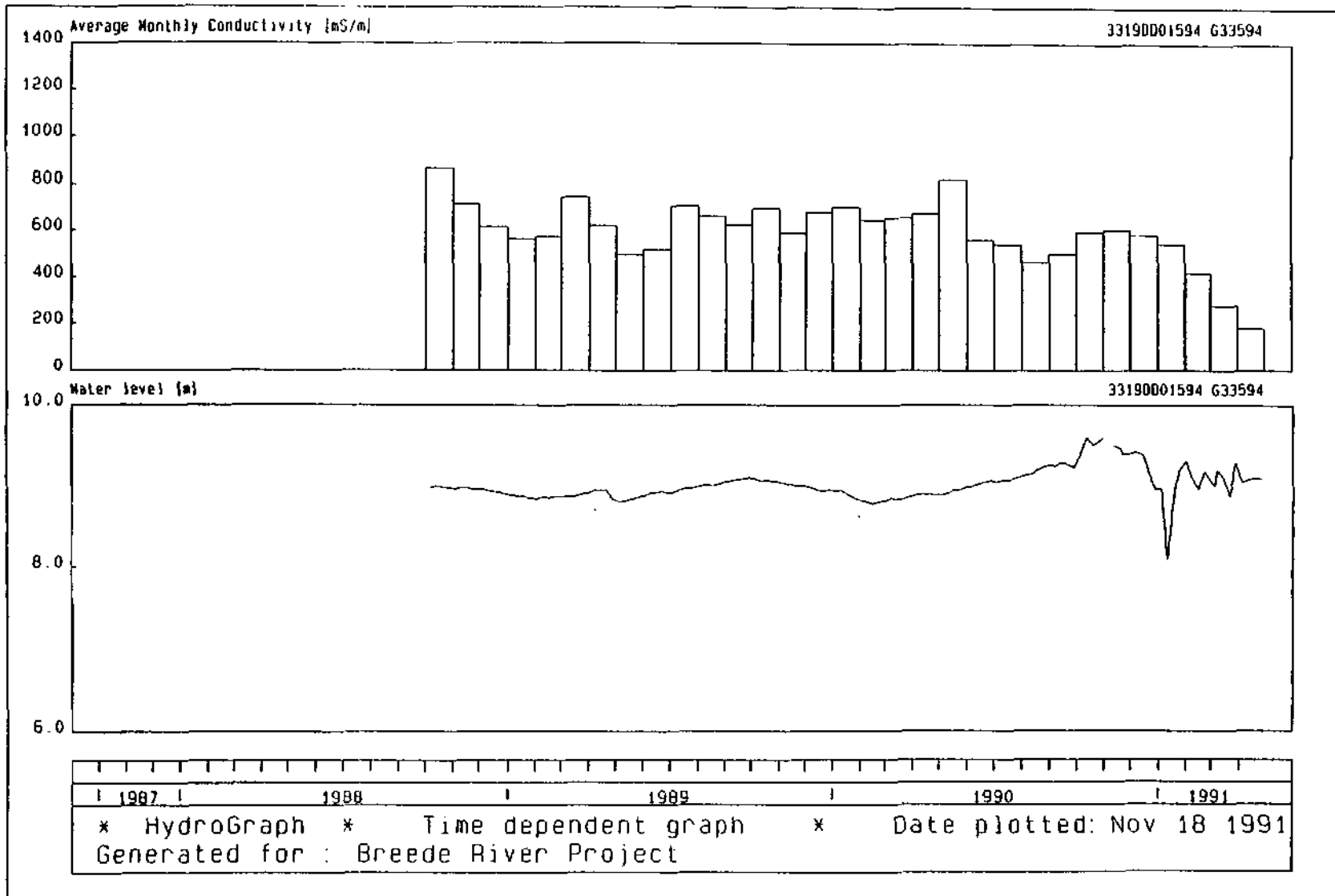

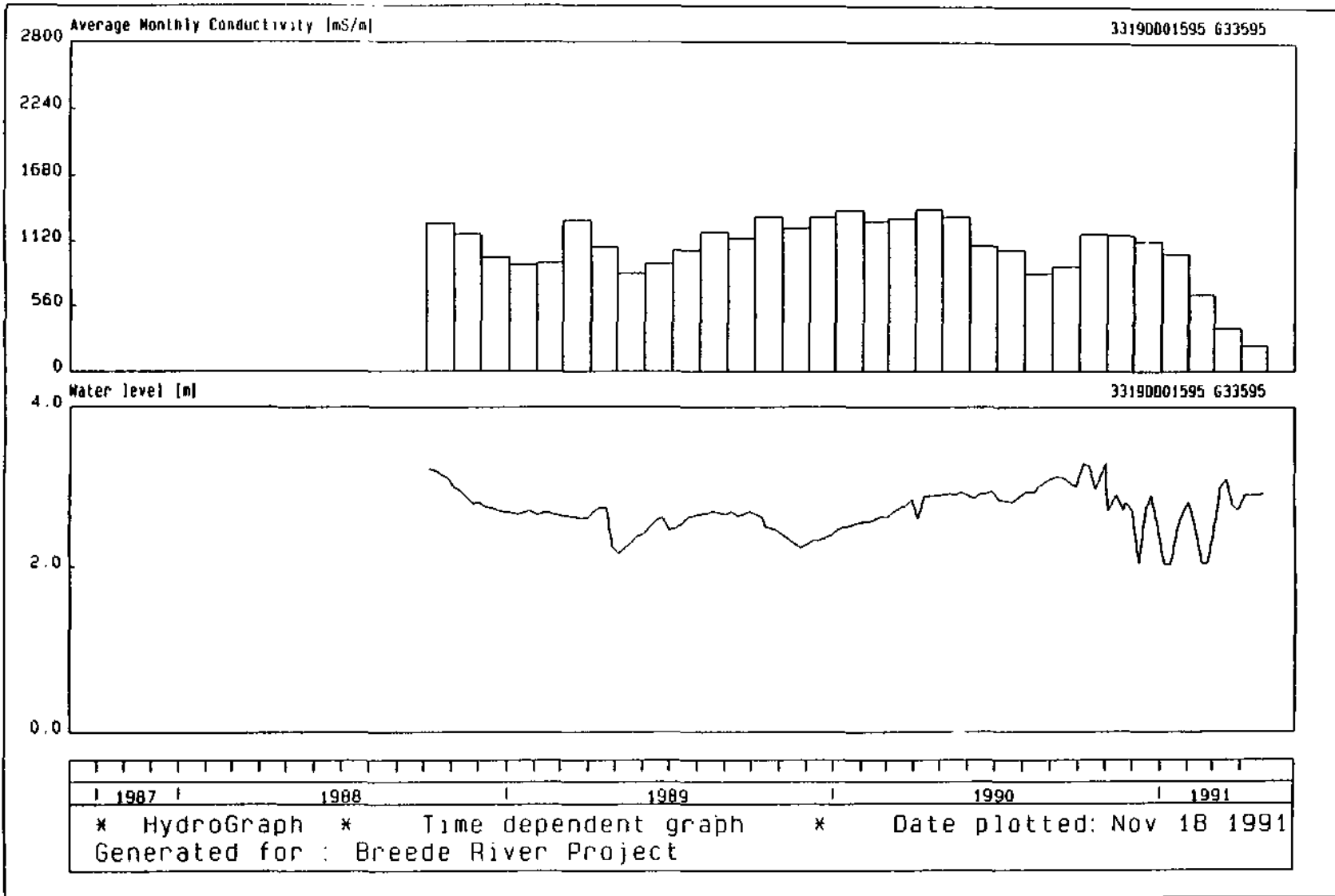

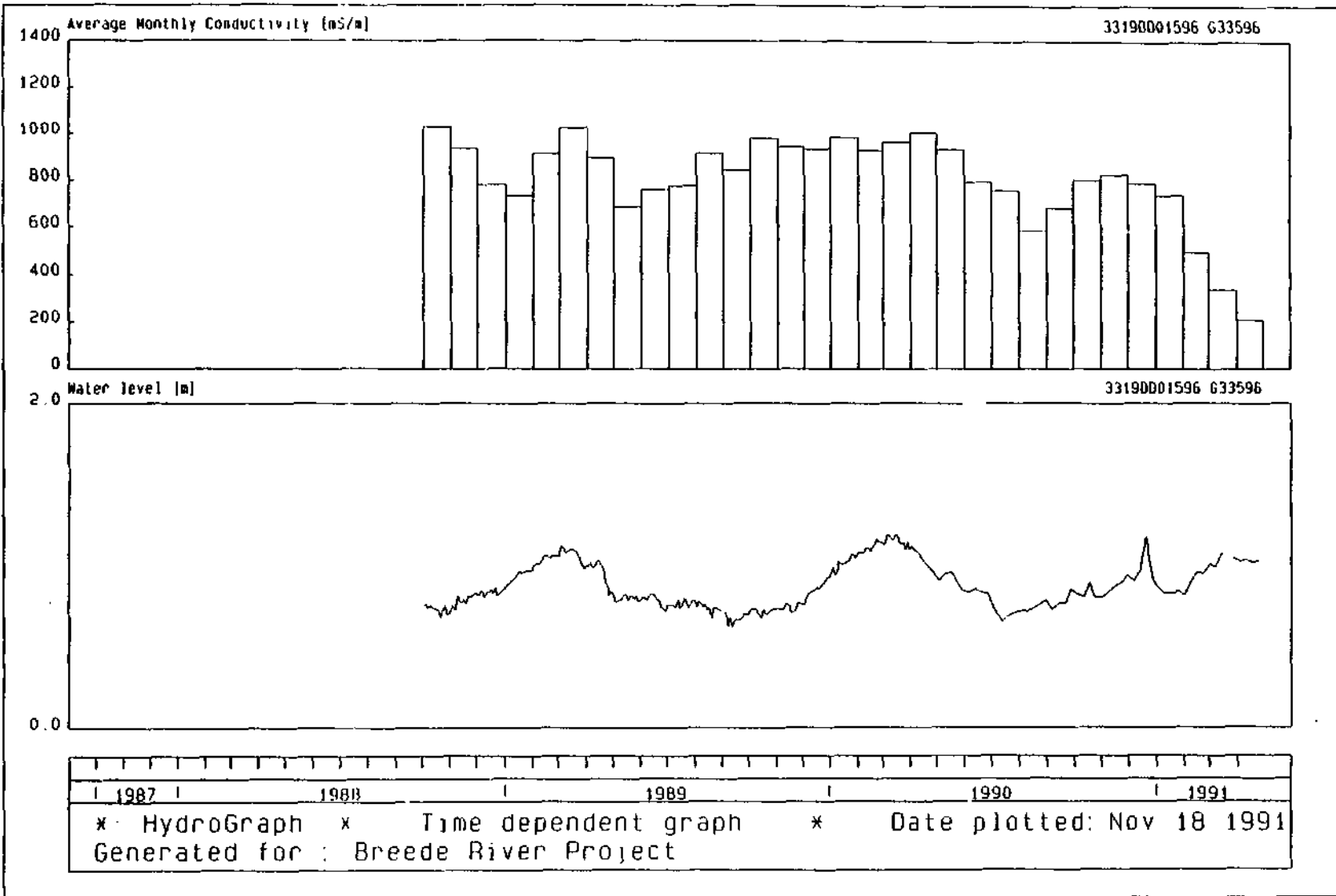

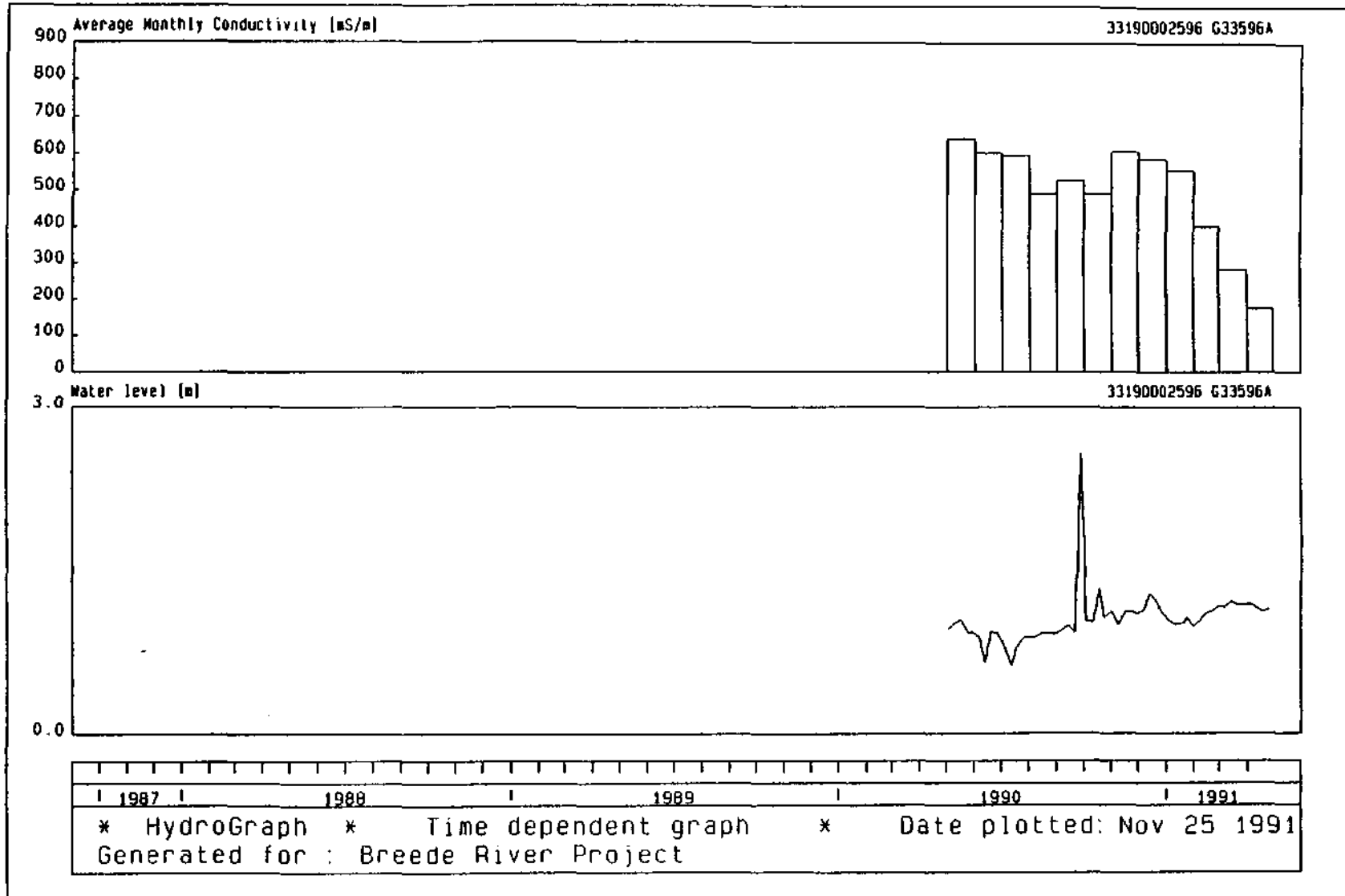

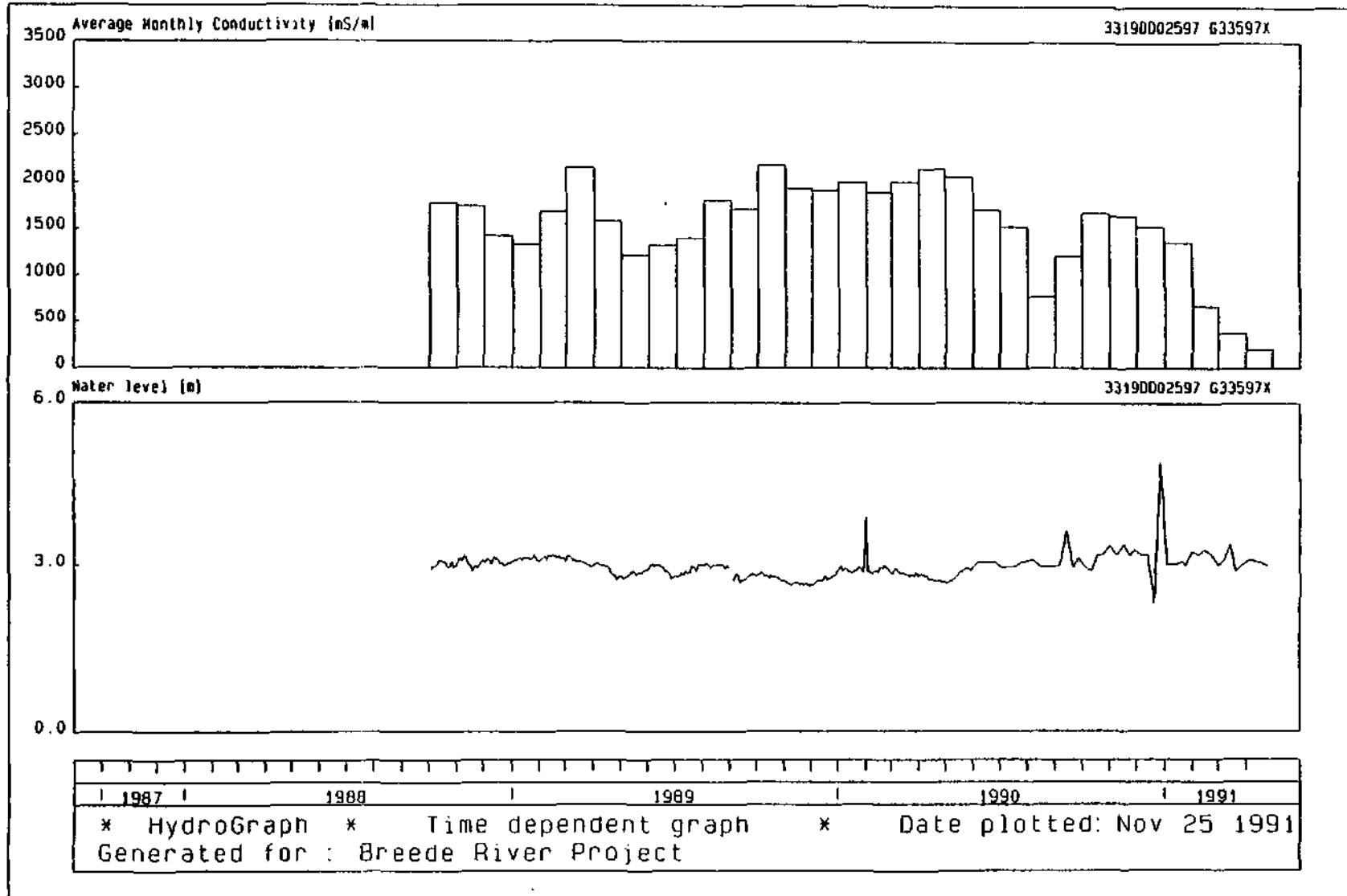

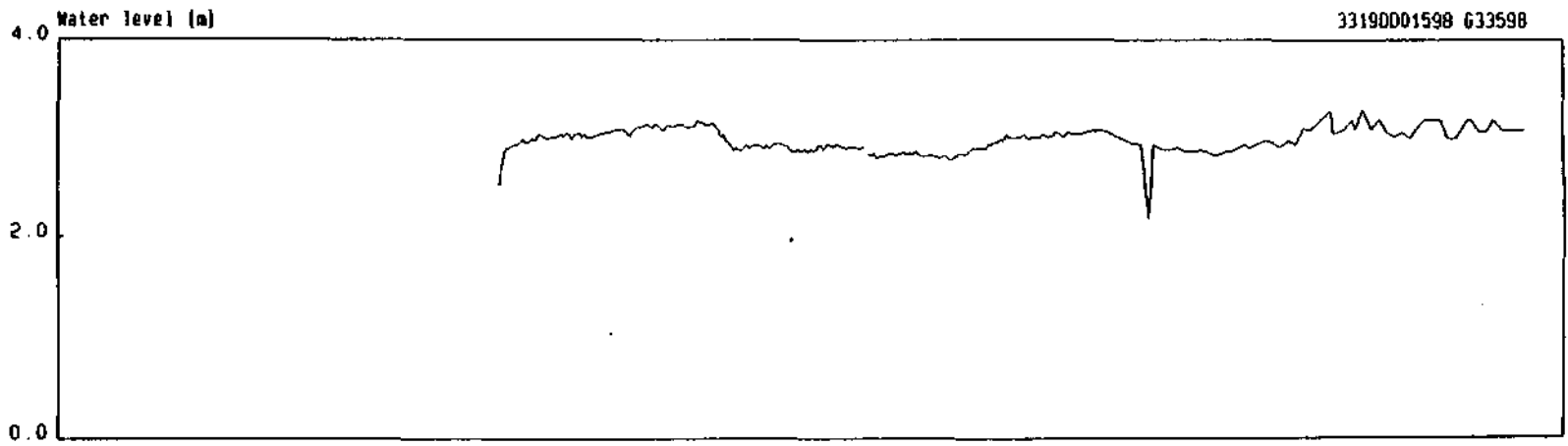
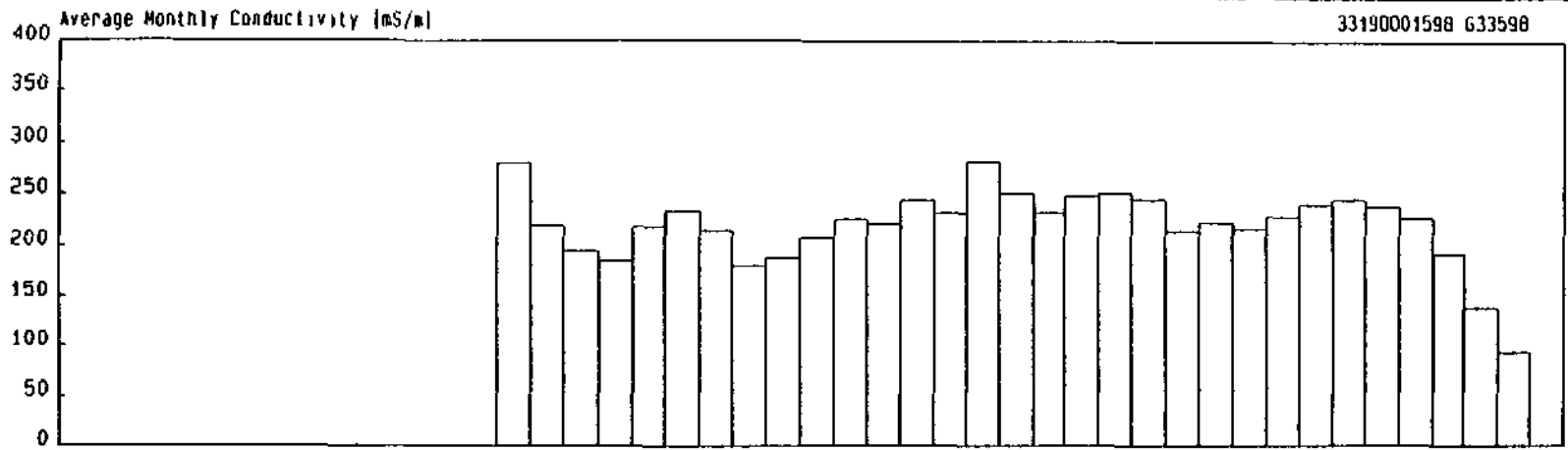

1987	1988		1989		1990		1991
* HydroGraph * Time dependent graph * Date plotted: Nov 18 1991							
Generated for : Breede River Project							

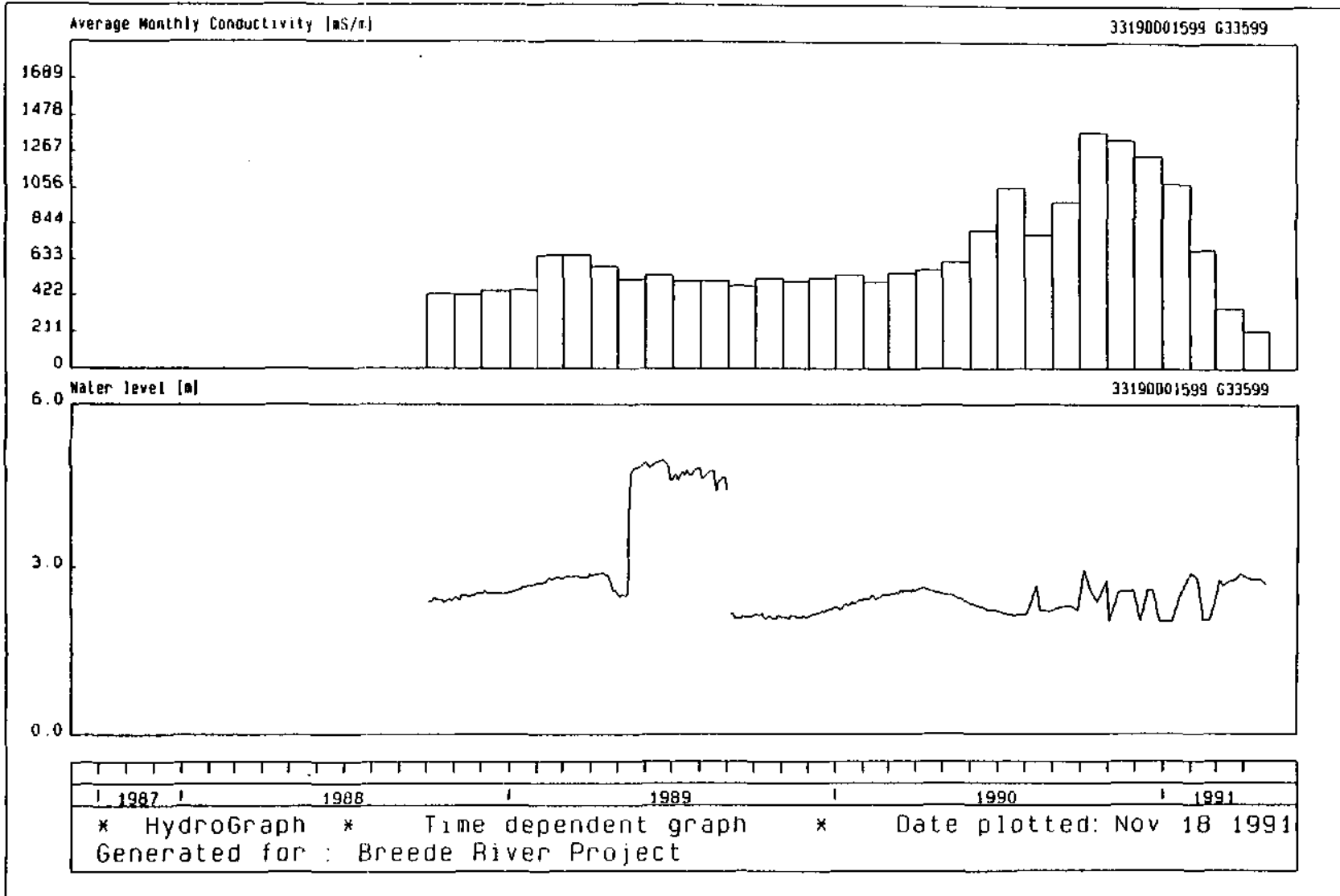

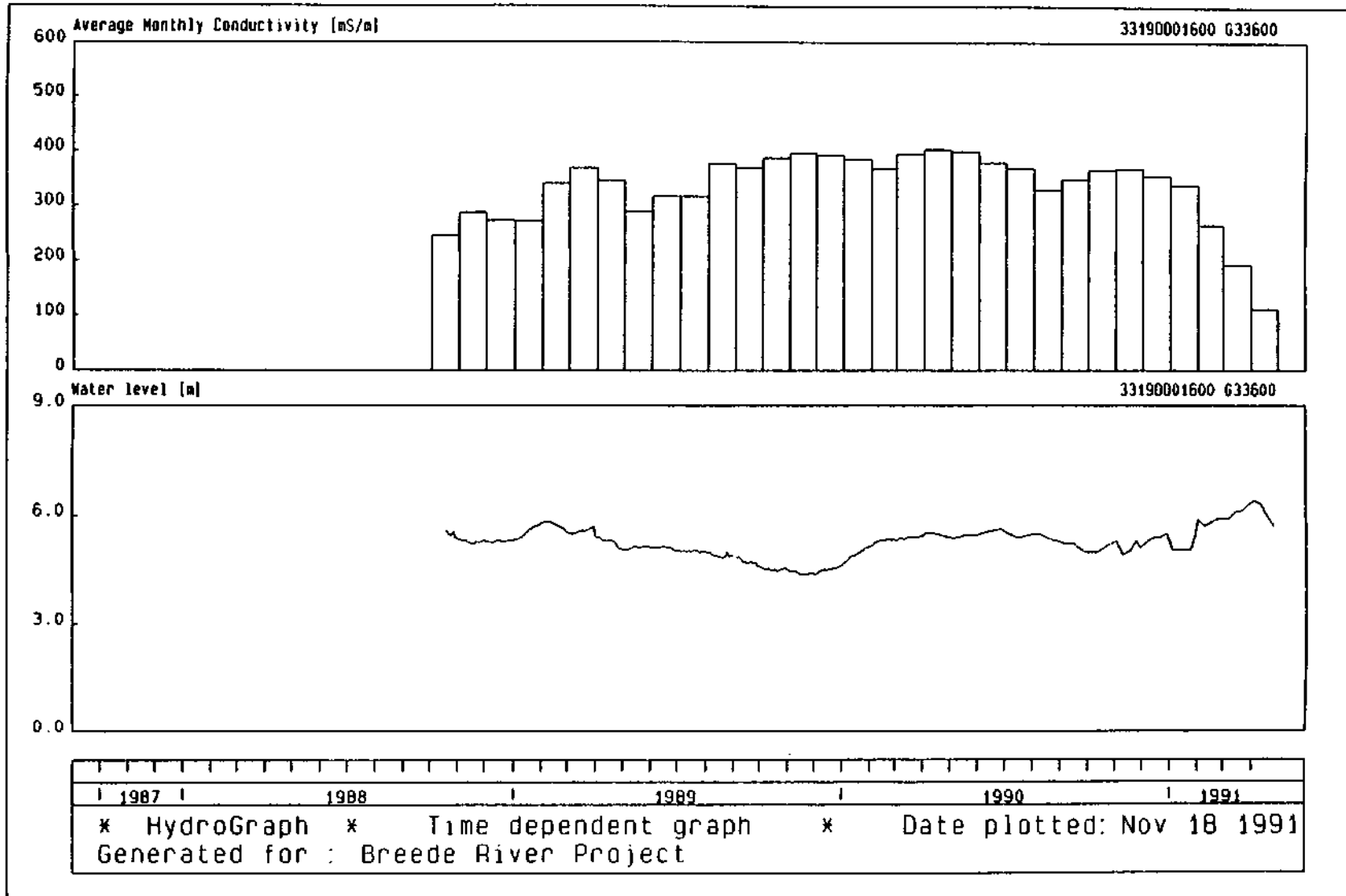

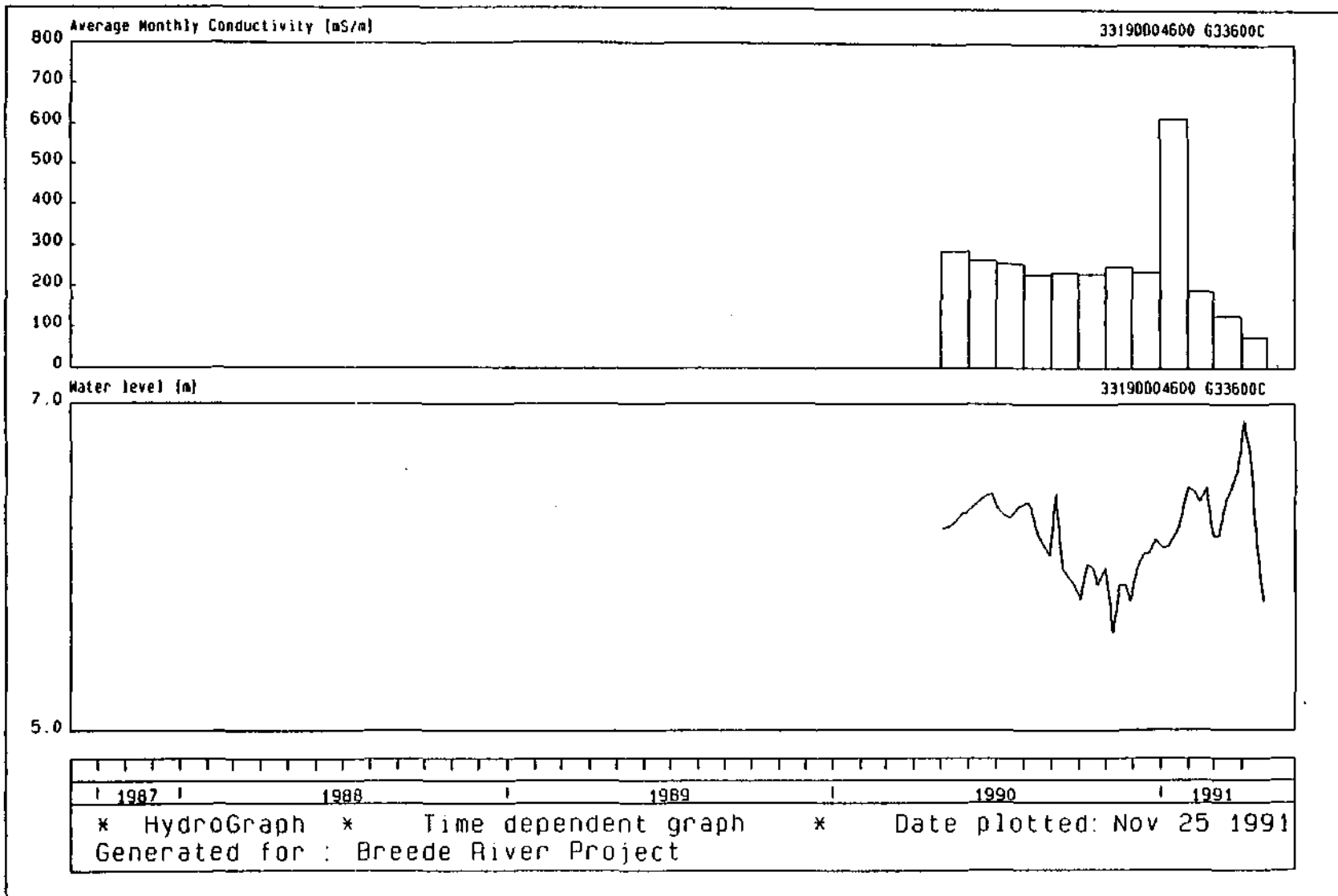

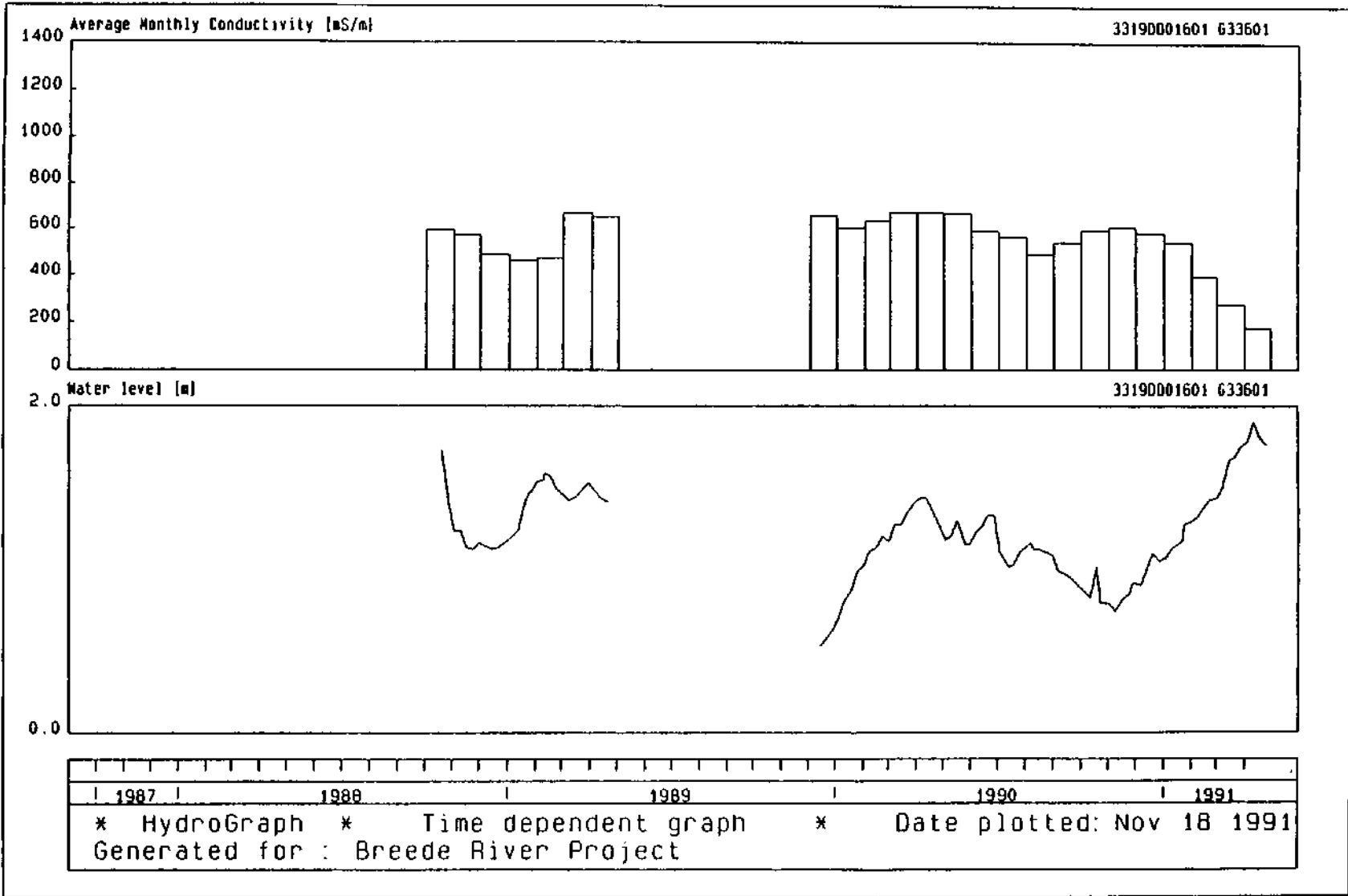

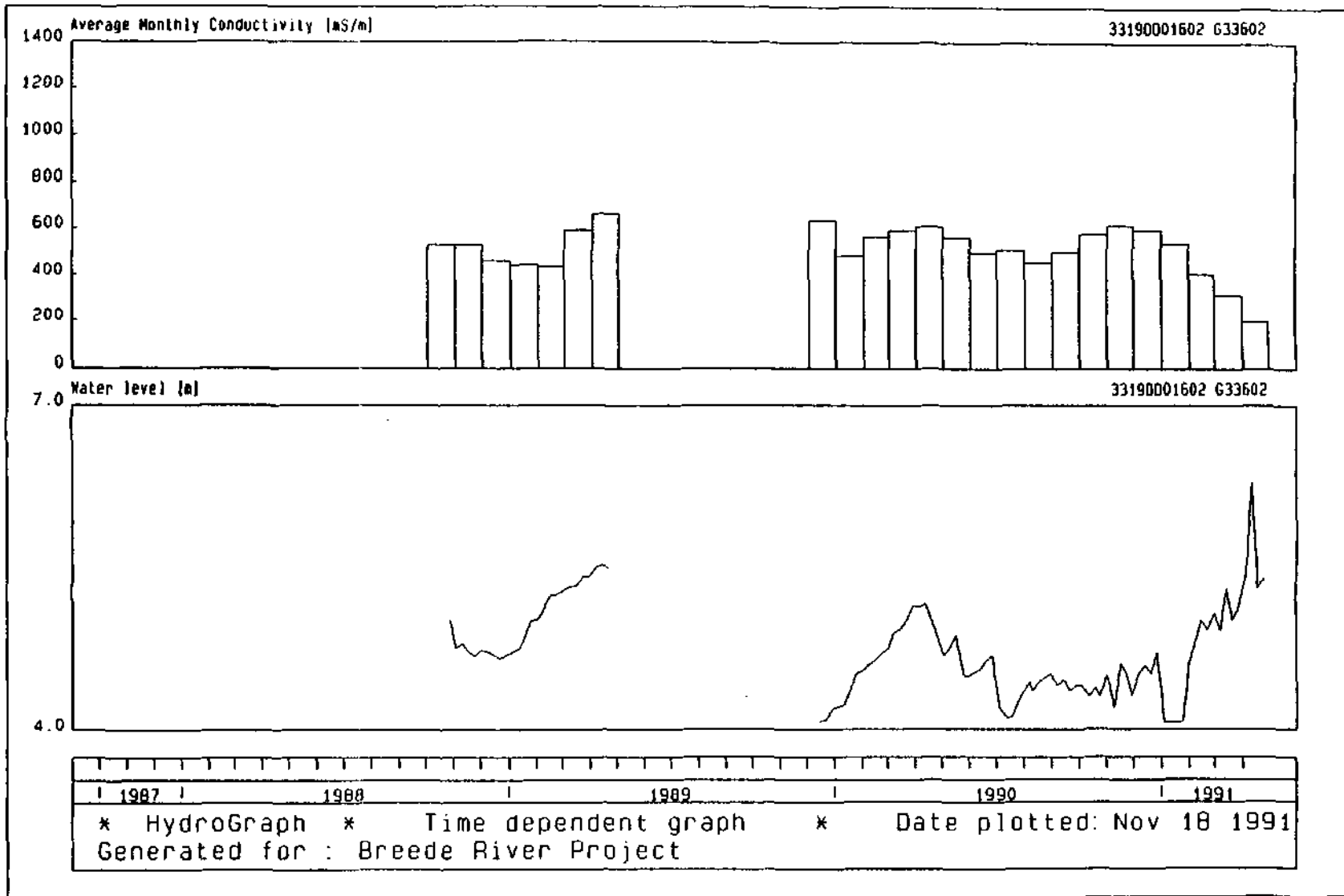

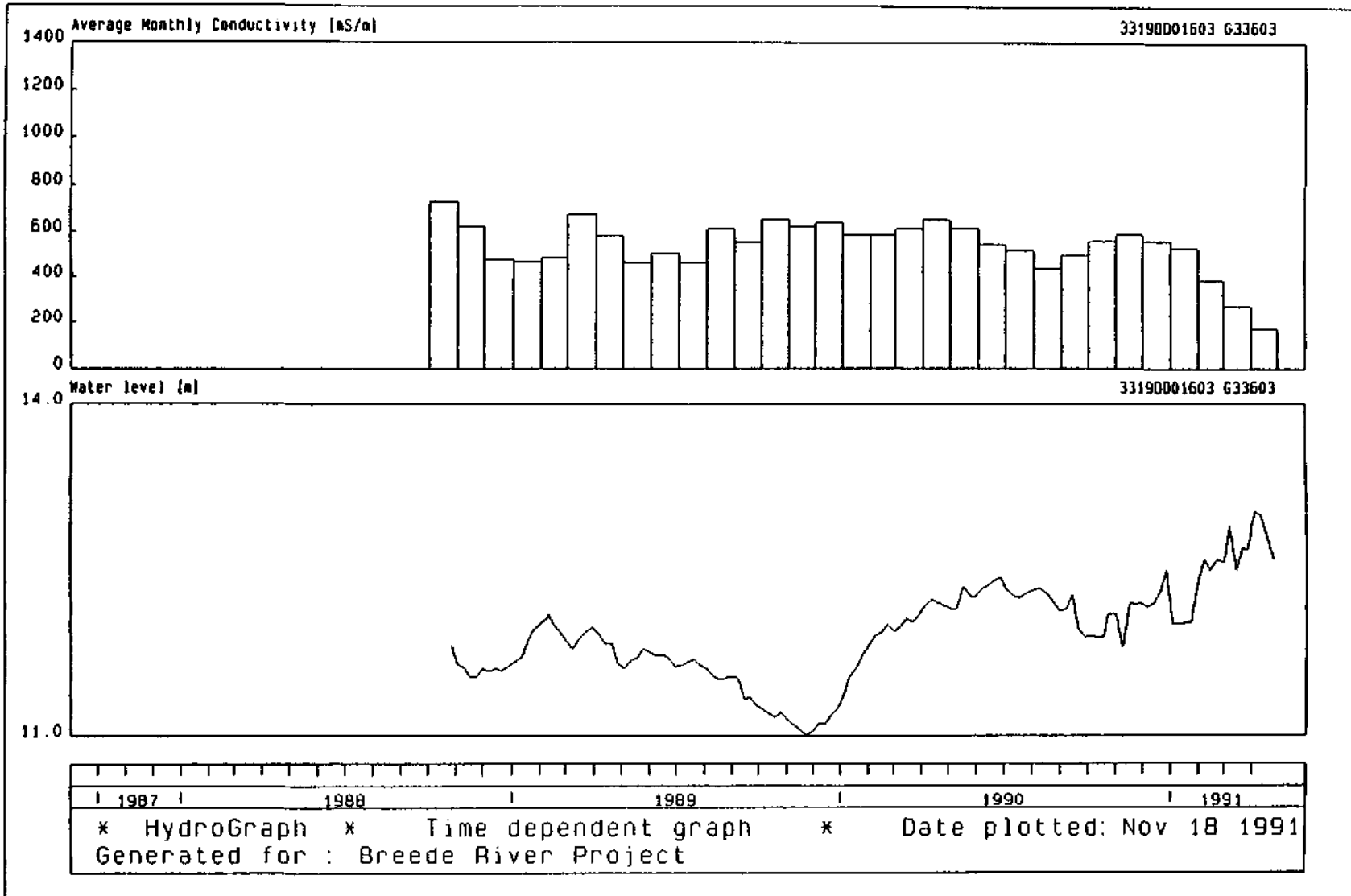

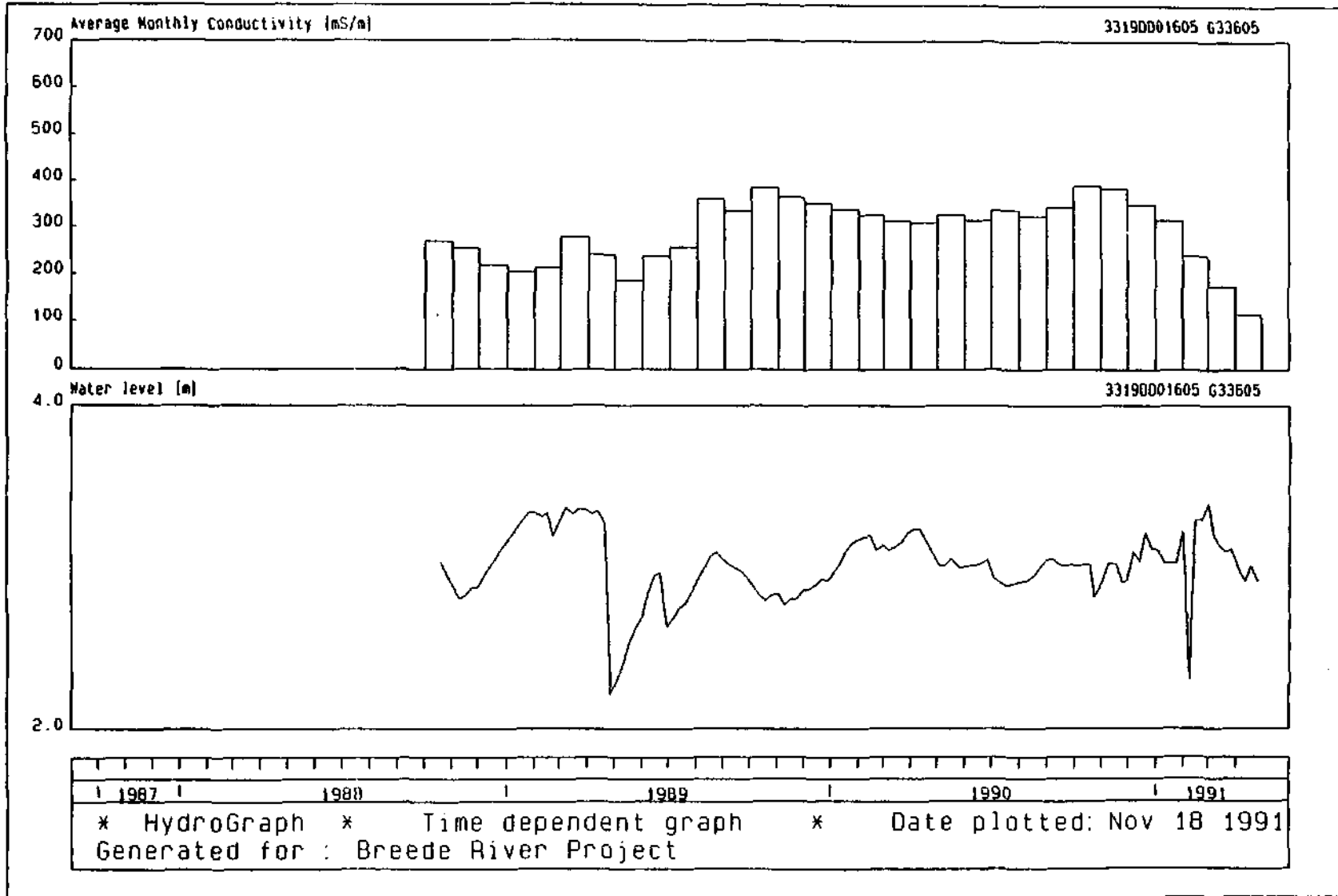

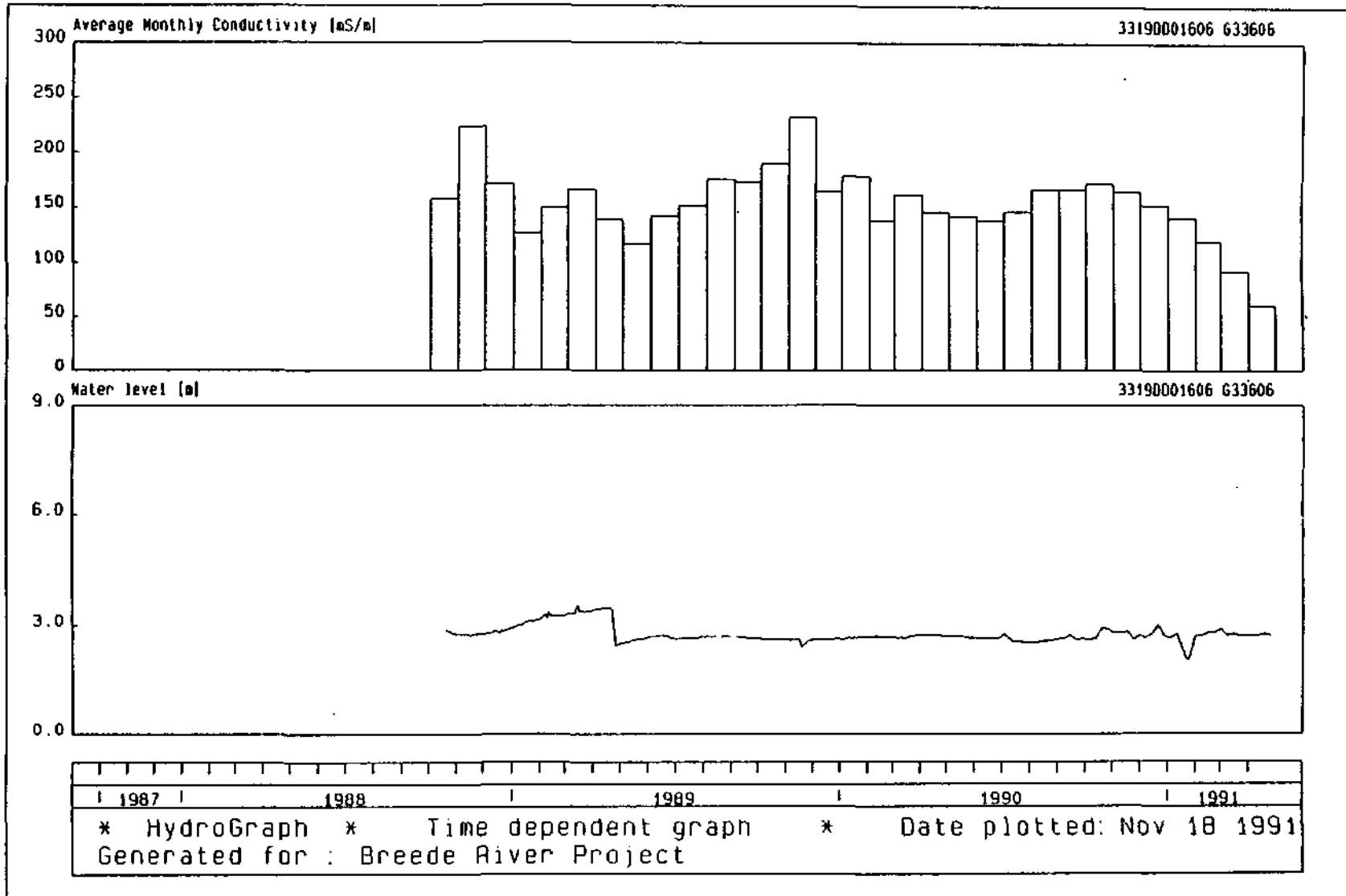

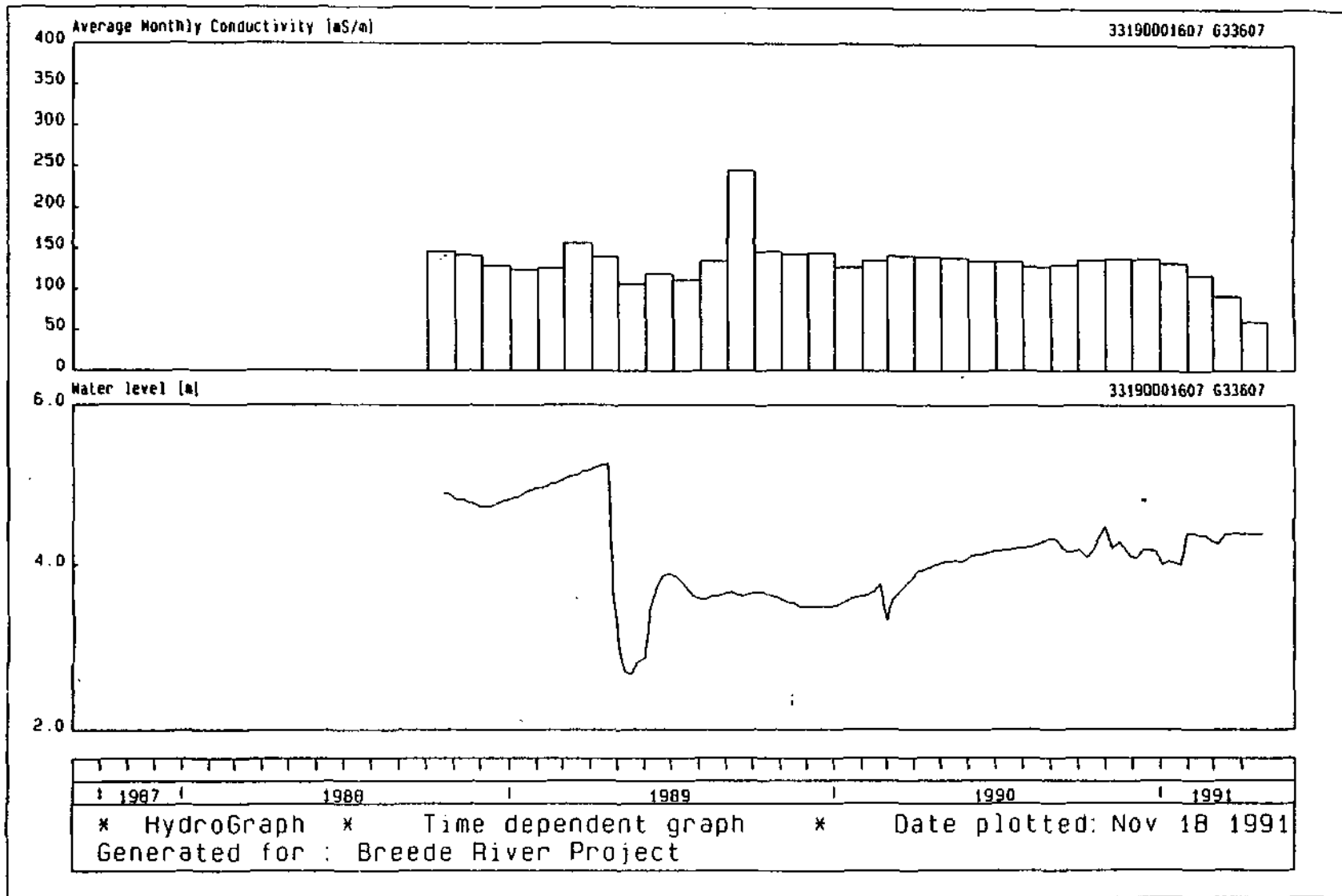

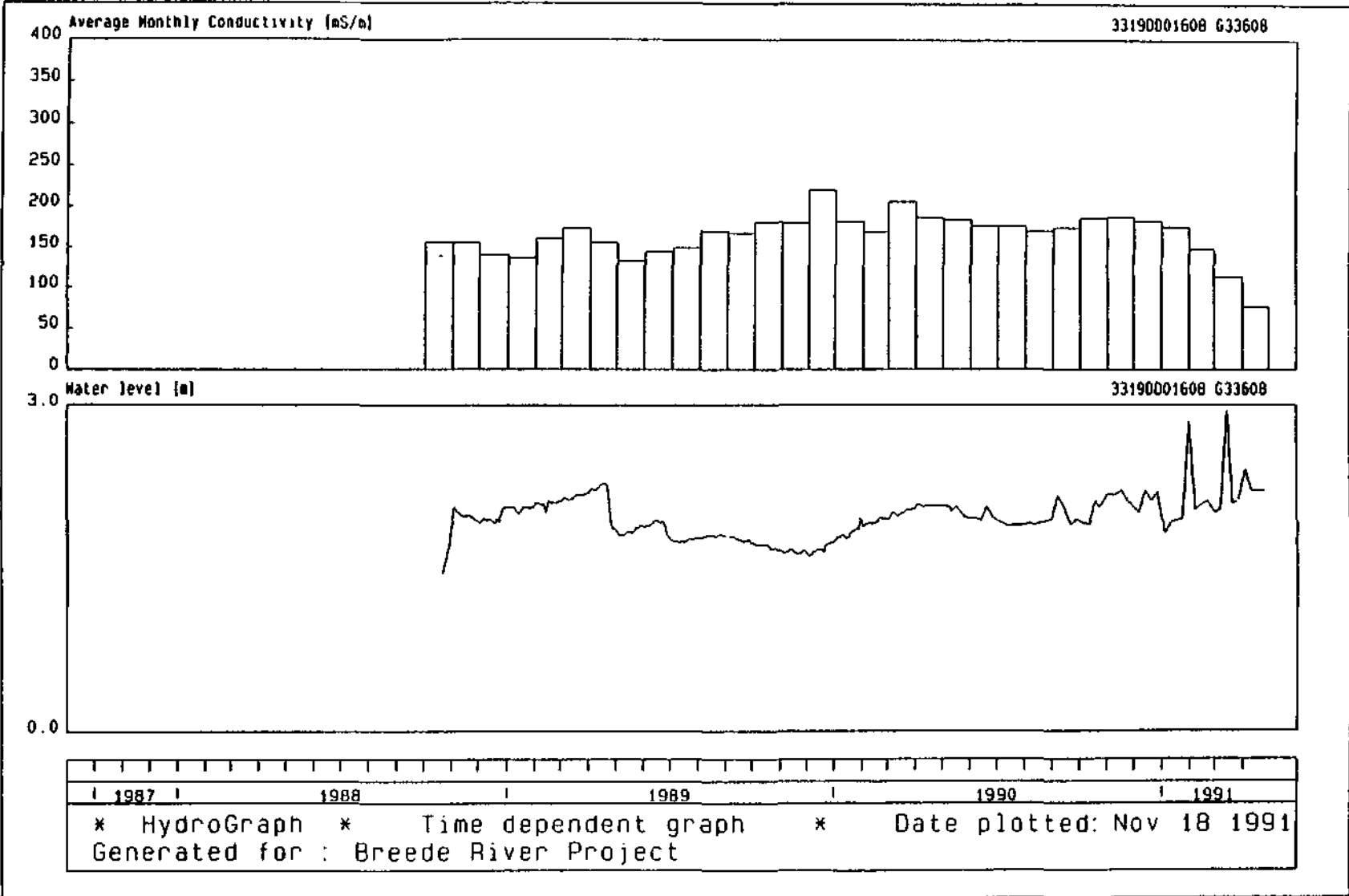

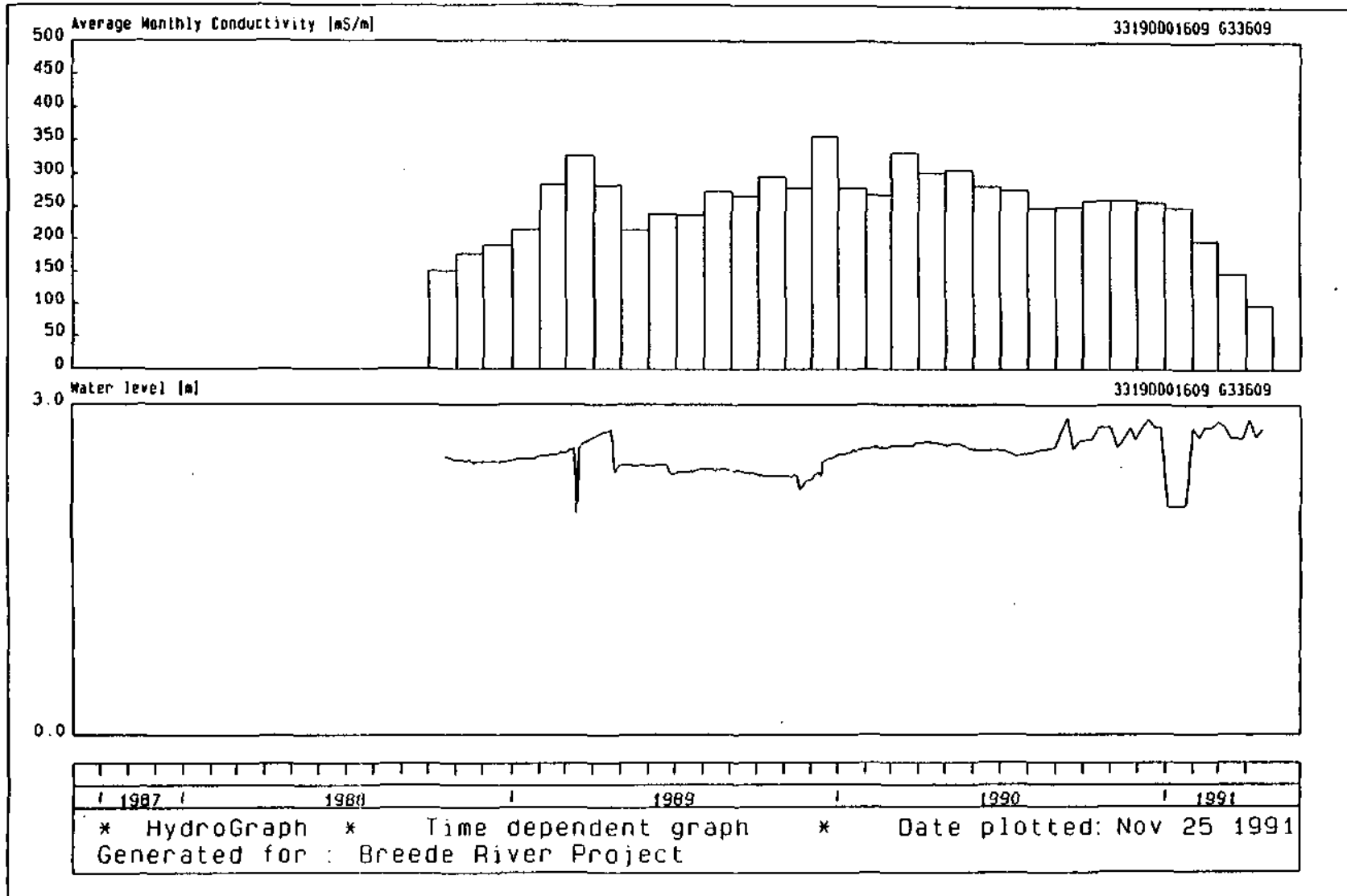

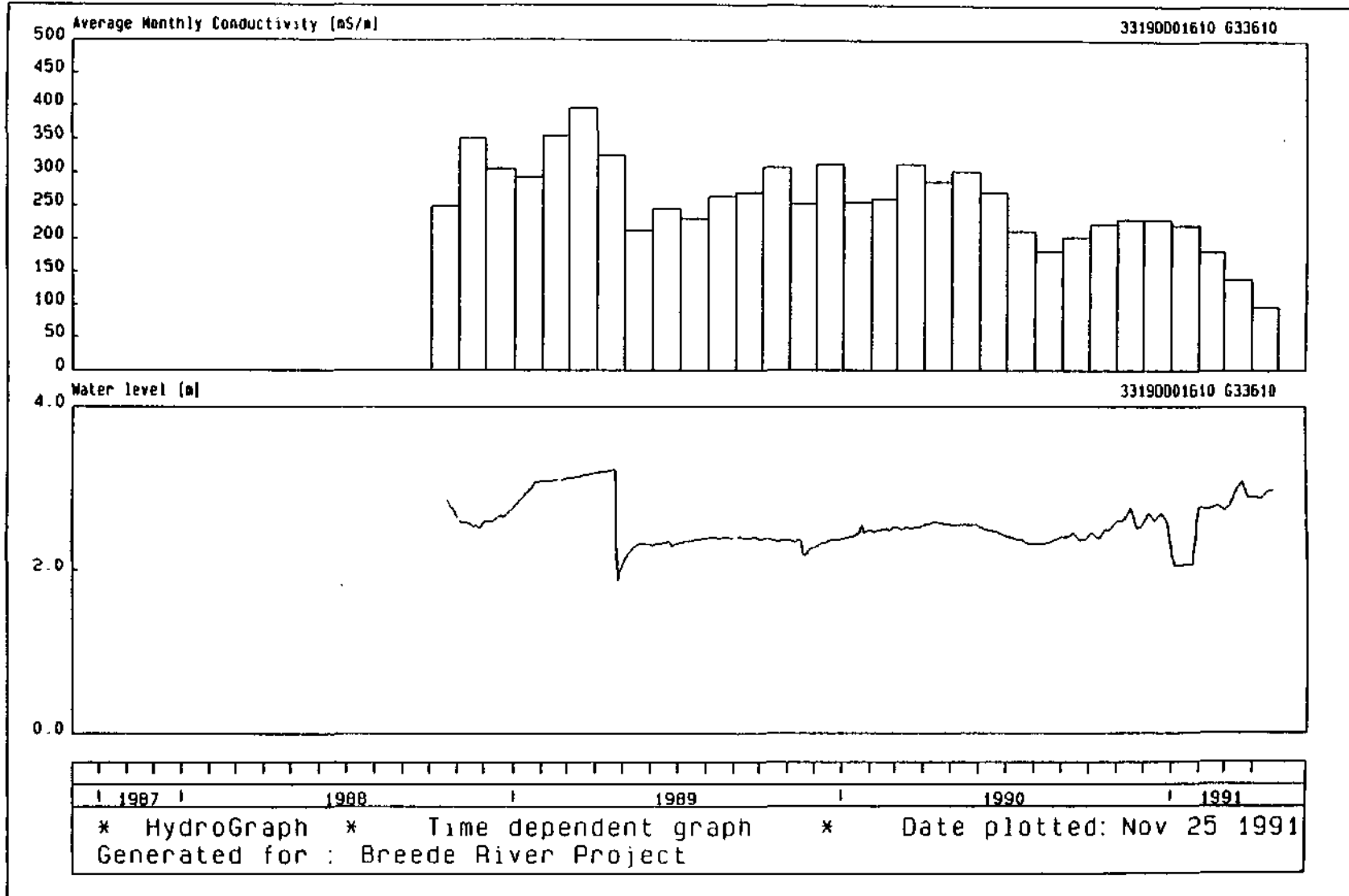

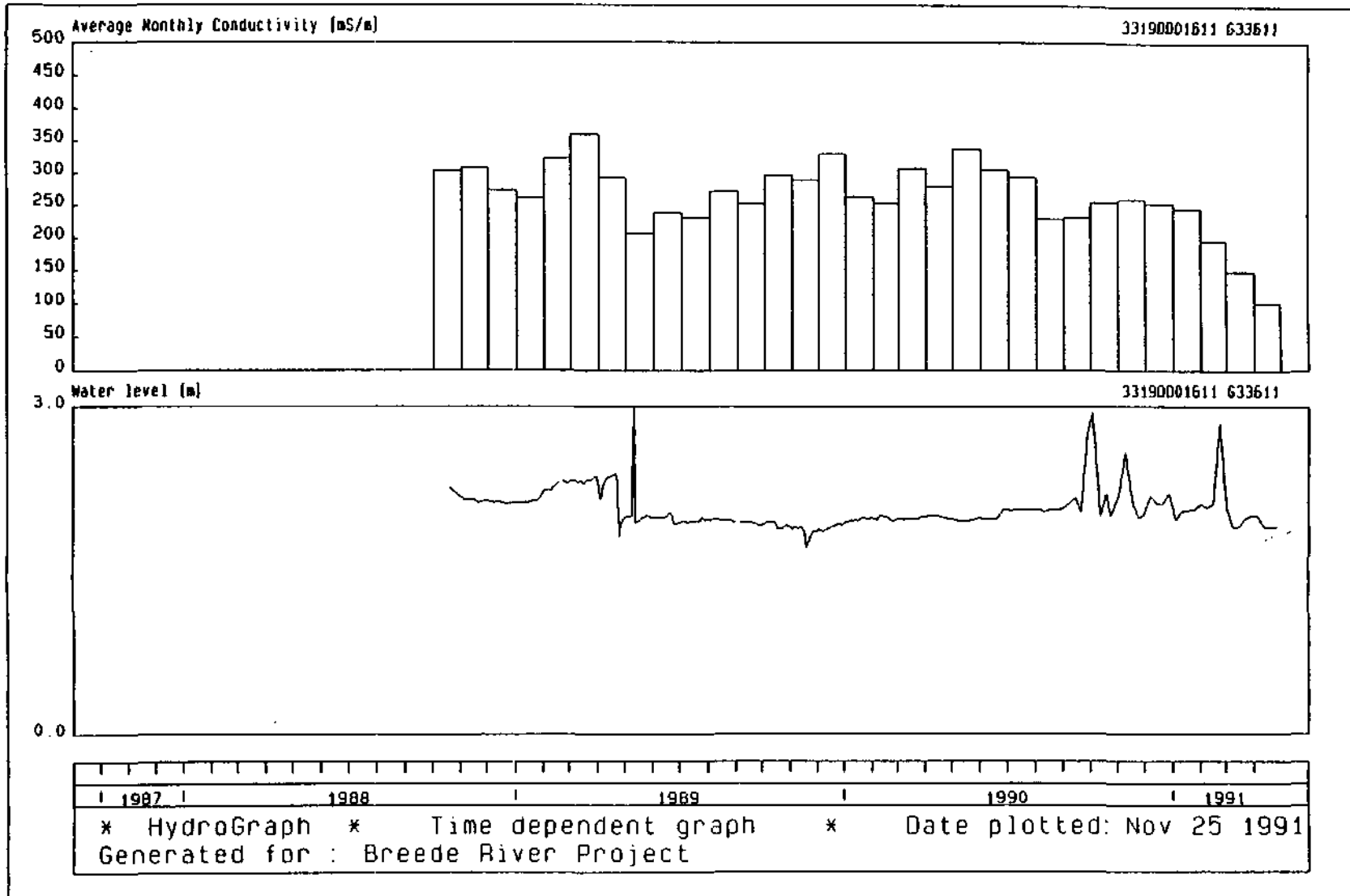

Appendix 5

Chemical analyses:
Macro elements

Site id	# on map	Sample #	Date	Time	Lab.	pH	EC mS/m	TDS () mg/L	Na mg/L	K mg/L	Ca mg/L	Mg mg/L	M.Alk mg/L	Cl mg/L	SO4 mg/L	F mg/L	NO3-N mg/L
3319CB00100	H1R01Y	A	19900530	1130	IGS (A)	6.34	10.0	82	16	1.5	6	4	10	24	10	0.6	1.2
3319CB00100	H1R01Y	H1R01Y	19900903	1530	IGS	6.76	12.0	87	15	1.1	7	4	14	26	11	0.4	0.9
3319CB00100	H1R01Y	H1R01Y	19901202	1730	IGS	6.35	14.0	99	18	0.4	8	5	18	30	11	0.2	0.7
3319CB00100	H1R01Y	A	19910226	1415	IGS	6.47	14.0	100	19	1.1	7	4	22	35	6	0.1	0.0
3319CB00101	BV	BV	19901202	1715	IGS	6.05	4.0	34	8	0.1	3	1	4	11	3	0.3	0.3
3319CB00101	BV	BV	19910226	1430	IGS	6.14	5.0	40	10	0.5	3	1	6	13	3	0.1	0.3
3319CB00102	RI		19881024	1000	HRI 1	5.90-	26.0	121	27	1.2	7	7	15	37	22	0.7<	0.1
3319CB00102	RI		19890425	1000	HRI 89617502	5.80-	22.0	108	23	1.7	5	5	18	33	17	0.0	0.0
3319CD00026	JF01	JF01	19900607	0930	IGS (JF1)	7.08	55.0	422	77	0.9	28	16	107	90	60	0.3	0.3
3319CD00027	JF02	JF02	19900607	0945	IGS (JF2)	6.88	34.0	255	45	0.6	20	11	47	54	54	0.3	0.5
3319CD00101	H4R04U	H4R04U	19881024	1100	HRI 2	5.00v	7.0	27	8	0.0	2	2	5	9	1	0.7<	0.0
3319CD00101	H4R04U	H4R04U	19890425	1010	HRI 89617514	5.60-	10.0	50	10	0.6	2	2	11	17	5	0.1	0.0
3319CD00101	H4R04U	H4R04U	19900530	1225	IGS (2)	6.59	5.0	47	11	0.8	3	2	6	15	5	0.7	0.4
3319CD00101	H4R04U	H4R04U	19900903	1600	IGS	6.39	4.0	38	9	0.9	3	1	5	12	4	0.5	0.3
3319CD00101	H4R04U	H4R04U	19901202	1800	IGS	6.03	4.0	38	9	0.1	3	1	5	12	4	0.3	0.3
3319CD00101	H4R04U	2	19910226	1500	IGS	6.07	5.0	40	10	0.8	3	1	6	13	3		0.3
3319CD00102	C2		19881024	1145	HRI 3	5.70-	11.0	55	10	0.9	4	3	9	20	4	0.7<	0.3
3319CD00102	C2		19890425	1015	HRI 89617526	5.70-	13.0	68	16	1.5	3	3	13	20	7	0.1	0.0
3319DA00002	NG01	NG1	19900605	1230	IGS (NG1)	7.56	8.0	100	10	2.1	7	5	39	10	9	0.7	0.4
3319DA00003	NG02	NG2	19900605	1215	IGS (NG2)	6.78	6.0	74	10	1.3	6	4	23	10	5	0.7	0.4
3319DA00003	NG02	NG2	19910301	0900	IGS	7.88	118.0+	888	195+	1.8	39	32	291	229	23	0.5	1.2
3319DA00004	NG03	NG3	19900605	1200	IGS (NG3)	6.30	5.0	56	9	0.4	3	3	12	12	4	0.7	0.4
3319DA00004	NG03	NG3	19900905	0000	IGS	6.95	11.0	89	9	0.9	3	2	43	12	2	0.5	0.3
3319DA00004	NG03	NG3	19901200	0000	IGS	6.01	6.0	67	12	0.5	4	3	16	15	4	0.3	0.4
3319DA00004	NG03	NG3	19910301	1000	IGS	4.43v	6.0	61	9	0.3	3	3	0	18	7	0.3	1.3
3319DA00005	NG04	NG4	19900605	1145	IGS (NG4)	6.14	5.0	52	8	0.9	3	3	14	11	0	0.7	0.4
3319DA00005	NG04	NG4	19900905	0000	IGS	6.23	5.0	51	8	0.8	3	2	13	10	3	0.6	0.3
3319DA00005	NG04	NG4	19901200	0000	IGS	5.89-	5.0	62	9	0.0	3	2	20	11	4	0.2	0.4
3319DA00005	NG04	NG4	19910301	1015	IGS	6.39	5.0	50	8	0.9	3	2	13	11	0	0.2	0.4
3319DA00006	NG05	NG5	19900605	1130	IGS (NG5)	5.86-	4.0	47	9	0.5	2	2	7	11	4	0.8	0.5
3319DA00006	NG05	NG5	19900905	0000	IGS	6.02	4.0	44	9	0.5	2	1	8	10	3	0.6	0.3
3319DA00006	NG05	NG5	19901200	0000	IGS	5.62-	4.0	41	9	0.0	3	1	6	10	3	0.3	0.4
3319DA00006	NG05	NG5	19910301	1030	IGS	5.49v	4.0	47	8	0.7	3	2	10	11	2	0.1	0.4
3319DA00007	NG06	NG6	19900605	1100	IGS (NG6)	5.90-	4.0	47	11	0.0	2	1	7	10	5	0.7	0.4
3319DA00008	VR01	VR1	19900605	0930	IGS (VR1)	8.37	113.0+	831	258+	1.5	12	5	217	250	30	1.1+	0.7
3319DA00008	VR01	VR1	19900903	1215	IGS	8.39	139.0+	1007	317+	1.6	13	5	272	306+	27	1.0	0.3
3319DA00008	VR01	VR1	19901203	1215	IGS	8.22	133.0+	977	303+	0.9	15	5	262	295+	29	1.3+	0.3
3319DA00008	VR01	VR01	19910226	0000	IGS	8.29	136.0+	920	296+	0.8	12	5	227	298+	23	1.8+	0.2
3319DA00101	R33		19881024	1230	HRI 4	8.10	323.0^	2075	512^	4.9	69	78+	425	658^	224+	2.7^	0.0
3319DA00101	R33		19890425	1200	HRI 89617538	7.00	32.0	219	51	2.5	9	3	80	44	6	0.5	0.1
3319DA00102	SMIT	SMIT	19900605	1000	IGS (SMIT)	8.01	70.0	643	153+	5.2	16	10	286	68	24	2.1^	1.0
3319DA00103	McG	McG	19900605	1015	IGS (McG)	7.69	290.0+	2140	517^	2.2	101	57	407	742^	213+	1.5+	0.4
3319DA00104	NGF	NGF	19900605	1115	IGS (NGF)	6.62	4.0	47	10	0.6	3	1	7	13	3	0.7	0.3
3319DB00005	KD01	KD01	19900531	1515	IGS (KD1)	7.27	131.0+	962	161+	1.7	68	37	333	262+	10	0.5	0.4
3319DB00005	KD01	KD1	19900903	1130	IGS	7.41	125.0+	901	160+	2.0	68	38	228	255+	82	0.5	0.3
3319DB00005	KD01	KD1	19901203	1040	IGS	7.46	124.0+	902	161+	1.3	71	37	222	255+	88	0.4	0.3
3319DB00005	KD01	KD1	19910226	0930	IGS	7.21	126.0+	906	158+	1.5	69	36	221	258+	95	1.0	0.2
3319DB00007	KD03	KD03	19900531	1545	IGS (KD3)	7.97	70.0	531	89	0.9	49	19	170	130	26	0.4	0.3

Site id	# on map	Sample #	Date	Time	Lab.	pH	EC mS/m	TDS { } mg/L	Na mg/L	K mg/L	Ca mg/L	Mg mg/L	H.Alk mg/L	Cl mg/L	SO4 mg/L	F mg/L	NO3-N mg/L
3319DB00007	KD03	KD3	19900903	1145	IGS	7.59	77.0+	569	88	3.0	56	21	170	136	47	0.3	0.3
3319DB00007	KD03	KD3	19901203	1025	IGS	7.47	76.0+	501	88	1.4	61	21	162	141	54	0.2	0.3
3319DB00007	KD03	KD3	19910226	0950	IGS	6.99	77.0+	574	80	2.0	60	19	160	143	61	0.5	0.1
3319DB00008	NE07	NE07	19890500	0000	IGS (D)	6.65	75.0+	529	102+	10.4	37	15	104	142	72	0.9	0.4
3319DB00009	NE05	NE05	19900531	0945	IGS (G)	7.00	11.0	116	13	1.6	14	3	44	14	4	0.6	0.4
3319DB00011	NE03	NE03	19881024	1400	HRI 6	6.20	48.0	207	29	2.2	40	3	9	121	0	0.7<	0.2
3319DB00011	NE03	NE03	19890425	1300	HRI 89617551	6.00	10.0	59	7	0.5	5	1	22	9	6	0.1	0.0
3319DB00011	NE03	NE03	19900531	0930	IGS (G)	7.12	137.0+	731	173+	5.0	54	17	24	422+	23	0.5	0.4
3319DB00011	NE03	NE03	19900903	1000	IGS	7.72	185.0+	1224	194+	6.0	133	49	189	465+	129	0.6	0.3
3319DB00011	NE03	NE3	19901200	0000	IGS	7.81	150.0+	941	184+	5.2	87	31	106	439+	59	0.5	0.3
3319DB00011	NE03	NE3	19910301	0000	IGS	6.97	6.0	66	11	0.0	8	2	13	15	6	0.2	0.4
3319DB00012	NE02	NE02	19900531	0915	IGS (F)	7.18	53.0	407	67	1.8	32	15	107	96	41	0.4	0.6
3319DB00012	NE02	NE02	19900903	0930	IGS	7.04	53.0	387	56	1.5	41	13	97	103	39	0.3	0.8
3319DB00012	NE02	NE2	19901200	0000	IGS	7.05	45.0	341	48	0.1	44	8	90	89	30	0.1	0.0
3319DB00012	NE02	NE02	19910301	0000	IGS	6.82	56.0	406	53	1.2	55	11	100	107	42	0.3	0.3
3319DB00013	NE01	NE01	19900531	0900	IGS (E)	7.65	187.0+	1256	191+	3.1	144	42	210	404+	195	0.9	0.3
3319DB00013	NE01	NE01	19900903	0915	IGS	7.47	174.0+	1203	180+	3.8	142	41	206	379+	187	1.6^	0.3
3319DB00013	NE01	NE1	19901200	0000	IGS	6.83	134.0+	939	147+	0.9	108	29	167	294+	140	1.0	0.5
3319DB00013	NE01	NE1	19910301	0000	IGS	7.03	27.0	1415	221+	3.6	166+	48	224	454+	233+	1.7^	0.3
3319DB00016	NE08	NE08	19900605	0830	IGS (NE8)	7.28	80.0+	593	80	1.2	72	30	182	102	72	0.4	0.4
3319DB00016	NE08	NE08	19900903	1245	IGS	7.57	44.0	367	46	1.2	34	18	151	57	17	0.3	0.4
3319DB00016	NE08	NE8	19901203	1120	IGS	7.77	75.0+	633	72	1.0	72	27	256	88	51	0.2	0.3
3319DB00016	NE08	NE8	19910226	1100	IGS	7.48	86.0+	699	77	1.2	75	29	269	104	73	0.7	0.3
3319DB00102	F1	F1	19881024	1300	HRI 7	5.80-	8.0	36	7	0.5	4	0	8	13	0	0.7<	0.0
3319DB00102	F1	F1	19890425	1315	HRI 89617563	7.10	195.0+	1060	170+	3.8	102	43	196	369+	121	0.5	0.0
3319DB00102	F1	F1	19900531	1015	IGS (7)	6.92	5.0	52	12	1.1	6	1	10	12	2	0.7	0.3
3319DB00102	F1	F1	19900903	1100	IGS	7.12	5.0	56	11	0.5	7	1	11	13	5	0.4	0.3
3319DB00102	F1	F1	19901200	0000	IGS	7.62	5.0	95	11	0.0	5	1	56	0	4	0.3	0.3
3319DB00102	F1	F1	19910226	1030	IGS	6.48	6.0	52	10	0.3	6	1	11	14	2	0.1	0.2
3319DB00103	H	H	19900531	1000	IGS (H)	7.34	27.0	199	48	1.0	10	6	31	73	8	0.5	0.4
3319DB00104	K	K	19900531	1310	IGS (K)	7.20	64.0	408	73	0.8	32	22	37	145	75	0.4	0.4
3319DB00105	L	L	19900531	1330	IGS (L)	7.76	29.0	242	34	1.1	29	6	95	33	17	0.6	0.4
3319DB00106	M	M	19900531	1345	IGS (M)	8.14	28.0	231	39	0.7	22	5	76	36	27	0.6	0.4
3319DB00107	KD2A	KD2A	19900531	1500	IGS (KD2A)	7.87	46.0	364	77	0.8	20	10	122	62	31	1.2+	0.7
3319DB00107	KD2A	KD2A	19901203	1020	IGS	7.30	40.0	315	70	0.0	17	8	111	59	6	1.0	0.5
3319DB00107	KD2A	KD2A	19910226	0955	IGS	7.22	40.0	322	67	0.8	15	8	110	60	24	1.1+	0.4
3319DC00002	DN02		19881025	1600	HRI 19	6.40	19.0	109	16	10.3	6	2	23	30	4	0.7<	0.0
3319DC00002	DN02		19890426	1230	HRI 89617680	6.90	119.0+	732	143+	21.7	31	33	155	283+	17	0.4	0.0
3319DC00006	DN06	DN6	19890426	1220	HRI 89617733	5.00v	20.0	102	23	2.3	2	3	13	44	5	0.3	0.0
3319DC00006	DN06	DN6	19900601	0000	IGS (DN6)	5.46v	15.0	108	29	1.7	4	4	5	48	6	0.4	0.6
3319DC00006	DN06	DN6	19900905	1140	IGS	6.46	21.0	144	25	2.5	3	3	40	47	4	0.4	0.5
3319DC00006	DN06	DN6	19901205	1330	IGS	5.21v	17.0	114	27	2.5	5	3	7	52	6	0.0	0.5
3319DC00006	DN06	DN6	19910227	1300	IGS	4.94v	14.0	99	24	2.3	3	3	5	48	3	0.3	0.5
3319DC00007	DN07	DN7	19881025	1530	HRI 17	7.30	180.0+	1110	235+	1.3	63	49	147	340+	226+	0.8	0.0
3319DC00007	DN07	DN7	19890426	1200	HRI 89617666	6.70	169.0+	1072	224+	1.7	60	45	176	305+	204+	0.6	0.0
3319DC00007	DN07	DN7	19900601	1320	IGS (DN7)	7.03	160.0+	1077	220+	0.9	62	42	159	328+	212+	0.4	0.3
3319DC00007	DN07	DN7	19900905	1045	IGS	6.90	152.0+	1091	228+	1.9	61	46	166	318+	212+	0.5	0.3
3319DC00007	DN07	DN7	19901205	1310	IGS	6.58	158.0+	1112	222+	0.0	64	45	164	327+	233+	0.5	0.3

Site id	# on map	Sample #	Date	Time	Lab.	pH	EC mS/m	TDS () mg/L	Na mg/L	K mg/L	Ca mg/L	Mg mg/L	H.Alk mg/L	Cl mg/L	SO4 mg/L	P mg/L	NO3-N mg/L
3319DC00007	DN07	DN7	19910227	1145	IGS	6.44	163.0+	1143	227+	1.2	64	44	155	353+	243+	1.8^	0.5
3319DC00008	DN08	DN8	19900601	0000	IGS (DN8)	7.74	147.0+	1096	340+	1.4	32	25	192	327+	123	1.0	0.4
3319DC00008	DN08	DN8	19900630	0000	IGS	8.18	151.0+	1030	269+	1.8	34	28	193	342+	108	0.9	0.2
3319DC00008	DN08	DN8	19900905	1015	IGS	7.51	153.0+	1085	283+	2.0	38	31	196	366+	114	0.8	0.3
3319DC00008	DN08	DN8	19901205	1230	IGS	7.34	162.0+	1107	284+	0.7	39	30	191	387+	121	0.6	0.4
3319DC00008	DN08	DN8	19910227	1130	IGS	7.17	164.0+	1105	279+	1.8	39	32	186	388+	126	1.6^	0.3
3319DC00010	PR01	PR01	19900601	1600	IGS (PR1)	7.19	83.0+	649	145+	2.0	35	11	215	139	39	1.2+	0.5
3319DC00010	PR01	PR01	19900905	1430	IGS	7.13	73.0+	558	121+	3.7	34	12	160	134	37	0.8	0.4
3319DC00010	PR01	PR1	19901205	1515	IGS	7.03	72.0+	628	129+	0.1	24	13	244	127	26	1.3+	0.0
3319DC00010	PR01	PR1	19910227	1600	IGS	6.96	75.0+	586	121+	3.2	35	11	192	132	35	1.2+	0.4
3319DC00027	PR18	PR18	19900602	0000	IGS (PR18)	5.76-	9.0	77	19	0.8	5	2	5	31	4	0.6	0.6
3319DC00027	PR18	PR18	19900905	1235	IGS	5.26v	10.0	73	18	1.7	3	2	4	31	4	0.4	0.5
3319DC00027	PR18	PR18	19901205	1350	IGS	4.87v	10.0	78	19	0.6	5	2	6	32	5	0.2	0.4
3319DC00027	PR18	PR18	19910227	1335	IGS	4.90v	10.0	65	17	1.3	3	2	0	31	3	0.3	0.5
3319DC00028	PY01	PY1	19900604	1200	IGS (PY1)	6.09	27.0	201	48	7.2	6	5	19	58	38	0.5	0.5
3319DC00028	PY01	PY1	19900907	1545	IGS	6.30	17.0	134	28	6.4	4	3	19	39	11	0.4	0.3
3319DC00028	PY01	PY1	19901206	1150	IGS	5.81-	16.0	135	27	7.3	6	3	18	40	11	0.2	0.4
3319DC00028	PY01	PY1	19910305	1015	IGS	6.19	18.0	151	30	7.2	5	3	22	43	13	0.2	2.0
3319DC00030	RY01	RY1	19900604	1100	IGS (RY1)	6.22	58.0	394	96	9.8	17	14	34	157	47	0.3	0.4
3319DC00030	RY01	RY1	19900907	1345	IGS	6.09	32.0	213	50	5.3	9	8	19	89	18	0.4	0.3
3319DC00030	RY01	RY1	19901206	1345	IGS	5.60-	15.0	114	27	1.0	9	3	11	44	8	0.2	0.5
3319DC00030	RY01	RY1	19910305	1315	IGS	5.56-	24.0	163	40	4.3	7	5	13	68	13	0.1	0.3
3319DC00033	RY04	RY4	19900604	1115	IGS (RY4)	6.90	53.0	345	80	9.4	14	13	31	127	56	0.4	0.6
3319DC00033	RY04	RY4	19900907	1415	IGS	7.48	54.0	339	80	8.9	12	13	34	142	30	0.3	0.3
3319DC00033	RY04	RY4	19901206	1355	IGS	6.91	53.0	379	82	9.6	15	12	49	155	33	0.4	0.3
3319DC00033	RY04	RY4	19910305	1345	IGS	6.88	53.0	413	80	8.1	12	11	90	137	30	5.7^	1.9
3319DC00036	RY07	RY07	19900604	0910	IGS (RY7)	7.14	116.0+	762	156+	4.5	43	30	95	271+	130	0.4	0.7
3319DC00037	RY08	RY08	19900604	1030	IGS (RY8)	7.77	237.0+	1573	375+	5.7	72	55	226	580+	196	1.1+	0.3
3319DC00039	RY10	RY10	19900604	0945	IGS (RY10)	7.71	69.0	489	98	8.0	37	17	69	129	97	0.2	0.4
3319DC00039	RY10	RY10	19900907	1205	IGS	6.72	101.0+	665	123+	6.8	42	31	78	193	159	0.3	0.3
3319DC00039	RY10	RY10	19901206	1510	IGS	6.67	104.0+	770	163+	6.7	48	31	95	236	157	0.3	0.3
3319DC00039	RY10	RY10	19910305	1100	IGS	6.69	216.0+	1413	295+	11.8	77	62	130	522+	258+	2.1^	1.7
3319DC00040	RY11	RY11	19900907	1200	IGS	7.69	140.0+	984	174+	10.4	52	44	156	234	261+	0.5	0.3
3319DC00040	RY11	RY11	19910305	1105	IGS	6.82	149.0+	1001	206+	9.2	63	37	145	334+	152	0.6	1.4
3319DC00041	RY12	RY12	19900604	0945	IGS (V)	7.30	211.0+	1454	276+	8.1	83	60	186	481+	303+	1.0	0.4
3319DC00041	RY12	RY12	19900907	1215	IGS	7.54	173.0+	1186	271+	8.3	56	39	184	358+	208+	0.7	1.0
3319DC00041	RY12	RY12	19901206	1530	IGS	7.13	207.0+	1496	356+	11.7	76	54	206	476+	257+	0.7	0.4
3319DC00041	RY12	RY12	19910305	1120	IGS	7.12	235.0+	1632	359+	10.1	88	63	215	524+	303+	2.7^	1.6
3319DC00042	RY13	RY13	19900604	1000	IGS (W)	9.48+	198.0+	1255	314+	8.2	64	42	98	474+	254+	0.8	0.5
3319DC00042	RY13	RY13	19900907	1215	IGS	7.35	201.0+	1350	279+	9.4	77	58	184	432+	257+	0.8	0.2
3319DC00042	RY13	RY13	19901206	1540	IGS	7.33	183.0+	1309	275+	8.5	83	52	185	405+	245+	2.0^	0.3
3319DC00042	RY13	RY13	19910305	1130	IGS	7.21	212.0+	1471	313+	10.0	83	60	197	463+	283+	1.4+	1.4
3319DC00101	H4M18	H4M18	19871005	1150	HRI	8.00	620.0^	4003	1029^	16.7	146	176^	357	1723^	471+	1.1+	0.2
3319DC00101	H4M18	H4M18	19871012	1123	HRI	7.90	579.2^	3594	866^	15.1	142	155^	332	1488^	515+	0.8	0.6
3319DC00101	H4M18	H4M18	19871019	1049	HRI	7.50	192.0+	1170	277+	5.3	56	55	116	487+	142	0.4	0.4
3319DC00101	H4M18	H4M18	19871026	1310	HRI	7.80	496.0^	2947	686^	9.3	135	143^	283	1265^	357+	0.7	0.3
3319DC00101	H4M18	H4M18	19871102	1305	HRI	7.80	473.6^	2813	642^	19.9	132	139^	279	1204^	325+	0.8	1.0
3319DC00101	H4M18	H4M18	19871109	1056	HRI	7.70	396.8^	2362	534^	15.6	113	116^	255	995^	266+	0.7	1.3

153

154

Site id	# on map	Sample #	Date	Time	Lab.	pH	EC mS/m	TDS () mg/L	Na mg/L	K mg/L	Ca mg/L	Mg mg/L	M.Alk mg/L	Cl mg/L	SO4 mg/L	F mg/L	NO3-N mg/L
3319DC00101	H4M18		19871116	1105	HRI	8.20	487.0^	2851	674^	14.3	126	144^	232	1250^	351+	0.6	0.6
3319DC00101	H4M18		19871123	1045	HRI	7.70	400.0^	2417	550^	68.9	107	114^	248	984^	278+	0.7	1.3
3319DC00101	H4M18		19871130	1057	HRI	7.90	350.2^	2034	461^	11.0	92	99+	223	858^	232+	0.6	0.9
3319DC00101	H4M18		19871207	0950	HRI	7.80	434.6^	2613	591^	13.2	117	129^	271	1128^	295+	0.8	0.6
3319DC00101	H4M18		19871214	0929	HRI	8.00	455.1^	2739	619^	13.0	125	135^	275	1202^	301+	0.8	0.4
3319DC00101	H4M18		19871221	1114	HRI	8.00	416.5^	2480	558^	14.1	109	123^	264	1062^	281+	0.8	0.9
3319DC00101	H4M18		19871228	1026	HRI	7.90	376.8^	2188	485^	14.3	117	109^	253	925^	214+	0.9	1.4
3319DC00101	H4M18		19880104	1100	HRI	7.70	399.9^	2282	522^	12.9	110	118^	248	955^	250+	0.7	1.0
3319DC00101	H4M18		19880111	1040	HRI	7.90	429.7^	2456	565^	11.5	120	127^	249	1048^	272+	0.8	0.4
3319DC00101	H4M18		19880118	1050	HRI	7.60	236.4+	1249	271+	6.0	62	63	126	557+	131	0.4	0.1
3319DC00101	H4M18		19880125	1010	HRI	7.90	411.1^	2374	542^	15.0	111	121^	254	989^	271+	0.8	1.6
3319DC00101	H4M18		19880201	1120	HRI	7.70	358.3^	2011	453^	8.4	100	103^	209	856^	228+	0.7	0.2
3319DC00101	H4M18		19880208	1000	HRI	8.10	431.8^	2508	568^	11.3	131	122^	253	1086^	273+	0.7	0.1
3319DC00101	H4M18		19880215	1019	HRI	8.10	356.7^	2052	453^	8.7	118	105^	232	856^	220+	0.7	0.2
3319DC00101	H4M18		19880222	1044	HRI	8.10	464.6^	2786	619^	16.2	135	141^	272	1218^	309+	0.8	1.5
3319DC00101	H4M18		19880229	1050	HRI	8.00	411.2^	2391	532^	10.3	132	123^	252	1025^	253+	0.8	0.1
3319DC00101	H4M18		19880307	1040	HRI	8.00	502.4^	3008	687^	15.5	148	126^	267	1331^	363+	0.8	0.4
3319DC00101	H4M18		19880314	1008	HRI	7.90	757.8^	4497	1109^	27.1	191+	202^	226	1963^	715^	0.9	1.1
3319DC00101	H4M18		19880321	1045	HRI	8.00	664.0^	3927	916^	16.2	193+	195^	317	1703^	505+	0.9	0.6
3319DC00101	H4M18		19880328	1005	HRI	7.50	196.8+	1005	241+	9.1	47	48	85	437+	114	0.3	0.2
3319DC00101	H4M18		19880404	1000	HRI	8.50	578.7^	3327	787^	27.8	156+	166^	313	1391^	389+	1.0	3.7
3319DC00101	H4M18		19880411	1100	HRI	7.40	508.4^	3092	742^	15.7	142	147^	249	1387^	344+	0.7	0.7
3319DC00101	H4M18		19880418	1047	HRI	7.50	532.4^	3258	785^	17.0	153+	159^	263	1446^	366+	0.7	0.8
3319DC00101	H4M18		19880425	1100	HRI	6.70	111.3+	589	145+	3.7	28	30	39	264+	67	0.2	0.1
3319DC00101	H4M18		19880502	1150	HRI	7.20	108.6+	572	137+	4.0	29	28	44	251+	65	0.1	0.3
3319DC00101	H4M18		19880509	1025	HRI	7.80	465.1^	2760	666^	12.8	126	135^	216	1247^	302+	0.6	0.2
3319DC00101	H4M18		19880516	1057	HRI	8.00	552.4^	3456	821^	16.8	146	163^	263	1588^	391+	0.7	0.3
3319DC00101	H4M18		19880523	1042	HRI	6.60	45.0	230	50	1.8	13	11	24	96	26	0.2	0.2
3319DC00101	H4M18		19880530	1145	HRI	7.70	447.8^	2702	651^	12.7	121	134^	212	1199^	318+	0.5	0.3
3319DC00101	H4M18		19880606	1100	HRI	6.30	56.0	296	71	2.2	14	15	24	126	36	0.1	0.2
3319DC00101	H4M18		19880613	1035	HRI	6.60	89.0+	465	112+	3.0	22	23	37	197	57	0.1	0.7
3319DC00101	H4M18		19880620	1041	HRI	7.60	382.0^	2242	530^	11.4	103	107^	194	1003^	242+	0.5	0.5
3319DC00101	H4M18		19880627	1010	HRI	7.00	106.3+	565	135+	3.4	27	28	48	238	67	0.2	0.8
3319DC00101	H4M18		19880704	1108	HRI	7.20	150.0+	836	192+	5.2	37	38	76	367+	96	0.1	0.9
3319DC00101	H4M18		19880711	1117	HRI	7.50	163.0+	936	218+	4.6	40	43	87	410+	111	0.4	0.2
3319DC00101	H4M18		19880718	1015	HRI	7.40	135.2+	764	173+	4.1	34	34	75	331+	90	0.2	0.7
3319DC00101	H4M18		19880725	1042	HRI	8.10	649.1^	3771	905^	20.1	167+	174^	335	1626^	461+	0.7	0.5
3319DC00101	H4M18		19880801	1125	HRI	8.00	638.9^	3637	864^	15.0	153+	167^	316	1626^	417+	0.9	0.4
3319DC00101	H4M18		19880808	1025	HRI	8.00	611.4^	3467	811^	15.0	147	160^	318	1534^	402+	1.0	0.7
3319DC00101	H4M18		19880815	1033	HRI	8.00	666.5^	3733	889^	19.5	145	174^	324	1661^	440+	0.8	0.7
3319DC00101	H4M18		19880822	1643	HRI	7.80	667.3^	3782	885^	19.5	153+	175^	335	1707^	423+	0.9	0.7
3319DC00101	H4M18		19880829	1114	HRI	8.60	800.0^	5413	1399^	24.3	161+	229^	364	2469^	673^	1.2+	1.1
3319DC00101	H4M18		19880905	1100	HRI	6.50	121.0+	701	173+	3.7	24	33	61	312+	76	0.2	0.5
3319DC00101	H4M18		19880912	1032	HRI	7.90	791.3^	4653	1140^	18.7	174+	209^	396	2066^	554+	0.9	0.5
3319DC00101	H4M18		19880919	1325	HRI	7.90	541.6^	3427	856^	13.4	113	152^	294	1507^	421+	0.8	0.3
3319DC00101	H4M18		19880926	1105	HRI	7.80	570.0^	3931	847^	162.9	171+	180^	344	1694^	451+	1.0	0.2
3319DC00101	H4M18		19881003	1130	HRI	7.90	500.0^	3458	812^	13.6	152+	171^	313	1508^	414+	0.7	0.2
3319DC00101	H4M18		19881010	1100	HRI	8.00	505.6^	3027	679^	15.1	138	153^	311	1288^	365+	0.7	1.1

Site id	# on map	Sample #	Date	Time	Lab.	pH	EC mS/m	TDS () mg/L	Na mg/L	K mg/L	Ca mg/L	Mg mg/L	M.Alk mg/L	Cl mg/L	SO4 mg/L	F mg/L	NO3-N mg/L
3319DC00101	H4M18	19881017	1045		HRI	7.90	492.8^	2931	670^	12.0	133	149^	284	1267^	348+	0.7	0.3
3319DC00101	H4M18	19881024	1023		HRI	8.10	448.5^	2721	627^	11.6	118	133^	286	1157^	319+	0.7	0.4
3319DC00101	H4M18	19881025	0845		HRI 12	7.90	458.0^	2683	607^	10.2	131	140^	261	1171^	301+	0.8	0.1
3319DC00101	H4M18	19881031	1115		HRI	8.10	422.3^	2593	583^	10.2	126	127^	282	1085^	311+	0.8	0.3
3319DC00101	H4M18	19881107	1012		HRI	8.00	403.0^	2453	544^	10.2	123	119^	281	1015^	292+	0.9	0.3
3319DC00101	H4M18	19881114	1126		HRI	7.80	335.5^	1999	435^	9.4	105	100+	250	797^	238+	0.8	0.9
3319DC00101	H4M18	19881121	1059		HRI	7.80	381.4^	2223	487^	10.8	114	114^	256	933^	247+	0.6	0.2
3319DC00101	H4M18	19881128	1146		HRI	8.10	414.7^	2434	544^	12.3	116	123^	250	1057^	272+	0.8	0.1
3319DC00101	H4M18	19881205	1110		HRI	8.00	500.0^	3127	703^	26.8	139	160^	354	1314^	327+	1.0	3.5
3319DC00101	H4M18	19881212	1205		HRI	8.10	543.7^	3427	784^	20.3	163+	173^	362	1478^	355+	1.0	0.9
3319DC00101	H4M18	19881219	1305		HRI	7.70	449.5^	2662	618^	26.8	117	127^	227	1167^	319+	0.9	1.0
3319DC00101	H4M18	19881226	0947		HRI	8.20	502.4^	3130	740^	23.2	115	163^	362	1252^	370+	1.1+	3.6
3319DC00101	H4M18	19890102	1025		HRI	8.20	521.8^	3203	745^	15.1	141	160^	329	1378^	354+	0.7	0.3
3319DC00101	H4M18	19890109	1050		HRI	8.30	530.4^	3246	765^	16.5	143	162^	348	1387^	337+	0.9	0.5
3319DC00101	H4M18	19890116	1130		HRI	8.20	611.2^	3408	794^	18.5	152+	172^	373	1452^	351+	1.0	0.8
3319DC00101	H4M18	19890123	1110		HRI	8.10	755.8^	4399	1063^	31.3	177+	214^	363	1941^	509+	0.9	2.2
3319DC00101	H4M18	19890130	1126		HRI	8.20	642.7^	3617	838^	19.0	166+	184^	398	1564^	347+	1.0	0.6
3319DC00101	H4M18	19890206	1140		HRI	8.20	635.9^	3594	828^	21.6	158+	180^	398	1541^	360+	1.1+	2.0
3319DC00101	H4M18	19890213	1100		HRI	7.90	479.8^	2893	677^	15.4	135	146^	329	1218^	287+	0.9	1.1
3319DC00101	H4M18	19890220	1130		HRI	8.20	473.4^	2829	654^	12.3	131	145^	304	1227^	281+	0.8	0.1
3319DC00101	H4M18	19890227	1142		HRI	8.20	627.7^	3474	792^	16.2	166+	175^	365	1525^	339+	1.0	1.3
3319DC00101	H4M18	19890306	1122		HRI	8.30	495.0^	3299	734^	17.0	160+	167^	348	1405^	379+	0.8	0.9
3319DC00101	H4M18	19890313	1142		HRI	8.00	600.0^	3888	934^	25.4	152+	177^	293	1771^	461+	0.7	0.8
3319DC00101	H4M18	19890320	1007		HRI	8.10	536.0^	3443	798^	18.1	160+	173^	346	1485^	374+	0.9	0.8
3319DC00101	H4M18	19890327	1230		HRI	8.50	495.0^	3254	744^	19.4	143	153^	339	1423^	340+	0.9	1.7
3319DC00101	H4M18	19890403	1200		HRI	8.10	524.0^	3495	789^	19.2	160+	174^	355	1525^	380+	0.9	1.3
3319DC00101	H4M18	19890410	1106		HRI	8.10	471.0^	3066	699^	13.5	150	153^	328	1328^	313+	0.8	0.2
3319DC00101	H4M18	19890417	1212		HRI	8.10	496.0^	3299	759^	15.2	160+	165^	345	1434^	335+	0.8	0.3
3319DC00101	H4M18	19890424	1130		HRI	7.70	137.0+	764	185+	5.8	29	30	68	327+	99	0.2	0.5
3319DC00101	H4M18	19890426	1030		HRI 89617617	7.50	501.0^	3016	706^	17.6	125	146^	283	1308^	359+	0.7	0.2
3319DC00101	H4M18	19890501	1055		HRI	7.60	86.4+	479	105+	3.2	21	22	48	199	65	0.1	0.4
3319DC00101	H4M18	19890508	1125		HRI	7.60	81.0+	462	102+	3.2	21	21	49	187	64	0.1	0.3
3319DC00101	H4M18	19890515	1100		HRI	7.40	63.4	349	77	2.1	17	17	35	147	43	0.1	0.1
3319DC00101	H4M18	19890522	1032		HRI	8.00	368.0^	2250	514^	10.2	98	106^	226	966^	272+	0.5	0.4
3319DC00101	H4M18	19890529	1112		HRI	7.80	399.0^	2437	570^	10.5	102	113^	243	1041^	296+	0.5	0.5
3319DC00101	H4M18	19890605	1157		HRI	8.00	799.0^	5215	1311^	20.2	193+	230^	450	2324^	576+	0.9	0.7
3319DC00101	H4M18	19890612	1123		HRI	8.40	703.0^	4765	1154^	21.3	171+	223^	469	2046^	561+	0.9	1.6
3319DC00101	H4M18	19890619	1124		HRI	8.40	495.0^	3260	814^	14.7	121	148^	299	1397^	390+	0.7	0.8
3319DC00101	H4M18	19890626	1110		HRI	8.30	584.0^	3902	1005^	16.9	113	165^	313	1687^	519+	0.7	1.4
3319DC00101	H4M18	19890703	1105		HRI	8.30	773.0^	5022	1261^	19.4	175+	226^	465	2163^	598+	0.8	1.0
3319DC00101	H4M18	19890710	1136		HRI	8.30	175.0+	967	242+	4.3	33	42	93	406+	119	0.3	1.0
3319DC00101	H4M18	19890717	1130		HRI	7.80	92.5+	534	127+	3.2	20	23	57	224	62	0.2	0.6
3319DC00101	H4M18	19890724	1212		HRI	8.20	733.0^	4698	1190^	16.4	141	204^	436	2036^	570+	0.8	0.6
3319DC00101	H4M18	19890731	1156		HRI	8.30	856.0^	5829	1506^	18.9	177+	248^	517	2547^	692^	1.0	0.6
3319DC00101	H4M18	19890807	1145		HRI	8.40	421.0^	2537	651^	10.1	74	105^	238	1105^	296+	0.6	0.3
3319DC00101	H4M18	19890814	1050		HRI	8.30	880.0^	5867	1549^	19.9	165+	250^	539	2532^	685^	1.0	0.4
3319DC00101	H4M18	19890821	1135		HRI	8.40	663.0^	4750	1225^	14.6	117	191^	474	2006^	613^	0.8	0.5
3319DC00101	H4M18	19890828	1140		HRI	8.30	396.0^	2649	717^	9.9	57	100+	243	1115^	350+	0.6	0.4

155

Site id	# on map	Sample #	Date	Time	Lab.	pH	EC mS/m	TDS () mg/L	Na mg/L	K mg/L	Ca mg/L	Mg mg/L	M.Alk mg/L	Cl mg/L	SO4 mg/L	F mg/L	NO3-N mg/L
3319DC00101	H4M18		19890904	1200	HRI	8.10	172.0+	1068	271+	5.4	32	45	102	457+	128	0.3	0.7
3319DC00101	H4M18		19890911	1205	HRI	8.10	188.0+	1179	302+	6.0	37	46	130	471+	154	0.3	0.4
3319DC00101	H4M18		19890918	1258	HRI	8.50	268.0+	1762	447^	6.6	58	71+	178	711^	247+	0.4	0.6
3319DC00101	H4M18		19890925	1120	HRI	8.30	453.0^	3055	769^	10.0	98	130^	291	1298^	390+	0.6	0.6
3319DC00101	H4M18	H4M18	19900601	1700	IGS POESJENELS	8.19	650.0^	4162	961^	21.0	155+	186^	412	1846^	469+	1.1+	2.3
3319DC00101	H4M18	H4M18	19900621	1555	IGS (H4M18)	7.78	140.0+	905	223+	4.4	34	38	88	382+	107	0.6	1.2
3319DC00101	H4M18	H4M18	19900723	0000	IGS	7.59	135.0+	918	226+	4.9	35	38	105	356+	123	0.5	0.9
3319DC00101	H4M18	H4M18	19900905	1610	IGS	8.47	465.0^	3268	846^	10.5	97	129^	378	1330^	404+	1.9^	0.3
3319DC00101	H4M18	H4M18	19900925	1504	IGS	7.97	488.0^	3442	841^	10.5	111	133^	437	1411^	398+	1.3+	0.4
3319DC00101	H4M18	POESJENE	19901025	1528	IGS	7.94	515.0^	3751	954^	9.9	132	151^	413	1614^	380+	2.4^	0.6
3319DC00101	H4M18	POESJENE	19901127	1123	IGS	8.00	431.0^	3058	678^	11.4	141	142^	342	1329^	332+	3.8^	0.7
3319DC00101	H4M18	POESJENE	19901205	0845	IGS	7.97	473.0^	2954	707^	14.1	156+	156^	330	1173^	334+	0.8	0.9
3319DC00101	H4M18	POESJENE	19901218	1515	IGS	8.00	478.0^	3816	920^	21.1	162+	182^	337	1663^	443+	3.5^	1.2
3319DC00101	H4M18	POESJENE	19910213	0000	IGS	7.73	321.0^	2631	586^	13.5	149	137^	295	1121^	253+	1.9^	0.6
3319DC00101	H4M18	POESJENE	19910302	1230	IGS	7.96	592.0^	3985	957^	17.1	183+	188^	366	1766^	404+	5.1^	2.1
3319DC00101	H4M18	POESJENE	19910319	0000	IGS	8.35	624.0^	4173	996^	23.8	196+	194^	409	1878^	394+	0.5	0.3
3319DC00101	H4M18	POESJENE	19910423	0000	IGS	8.39	500.0^	3297	757^	13.0	160+	160^	328	1504^	318+	0.7	0.0
3319DC00102	H4M17		19871005	1050	HRI	5.90-	20.8	106	23	1.1	5	5	13	37	15	0.1	0.4
3319DC00102	H4M17		19871012	0942	HRI	6.60	29.7	157	30	1.1	8	8	18	55	28	0.2	0.5
3319DC00102	H4M17		19871019	1020	HRI	6.40	30.7	170	33	1.2	8	8	18	56	36	0.1	0.4
3319DC00102	H4M17		19871026	1245	HRI	6.60	39.3	216	43	1.5	10	10	23	71	47	0.1	0.4
3319DC00102	H4M17		19871102	1235	HRI	6.70	30.0	153	31	1.2	8	8	18	55	24	0.1	0.2
3319DC00102	H4M17		19871109	1020	HRI	6.60	26.2	130	27	0.8	7	7	12	49	20	0.1	0.1
3319DC00102	H4M17		19871116	1045	HRI	6.60	30.7	147	32	1.1	7	7	15	57	21	0.1	0.1
3319DC00102	H4M17		19871123	1021	HRI	6.50	26.8	138	30	1.2	7	7	15	50	19	0.1	0.0
3319DC00102	H4M17		19871130	1025	HRI	6.80	28.9	150	33	1.6	6	7	15	56	22	0.1	0.1
3319DC00102	H4M17		19871207	0924	HRI	6.40	25.0	130	29	1.4	5	6	14	49	18	0.1	0.0
3319DC00102	H4M17		19871214	0902	HRI	4.90v	11.9	63	12	1.2	2	3	8	22	8	0.0	0.1
3319DC00102	H4M17		19871221	1050	HRI	6.20	20.3	105	24	1.4	4	5	10	42	14	0.0	0.0
3319DC00102	H4M17		19871228	0958	HRI	6.30	23.3	111	26	1.3	5	5	10	45	13	0.0	0.0
3319DC00102	H4M17		19880104	1035	HRI	6.10	24.0	104	24	1.3	4	5	8	40	14	0.1	0.1
3319DC00102	H4M17		19880111	1017	HRI	6.10	21.7	96	22	1.1	4	5	8	36	12	0.1	0.0
3319DC00102	H4M17		19880118	1030	HRI	6.10	20.2	82	21	1.0	3	4	3	34	10	0.1	0.0
3319DC00102	H4M17		19880125	0945	HRI	6.10	20.0	85	21	0.9	3	4	6	32	11	0.1	0.0
3319DC00102	H4M17		19880201	1100	HRI	6.10	19.9	85	21	1.0	3	4	4	33	10	0.1	0.0
3319DC00102	H4M17		19880208	0938	HRI	6.30	19.9	94	20	1.0	4	4	10	36	8	0.1	0.0
3319DC00102	H4M17		19880215	1000	HRI	6.20	14.7	74	16	0.9	3	3	9	30	6	0.1	0.0
3319DC00102	H4M17		19880222	1014	HRI	6.10	15.5	80	17	0.9	4	4	9	32	7	0.1	0.0
3319DC00102	H4M17		19880229	1030	HRI	6.20	17.1	90	19	1.0	4	4	10	35	9	0.2	0.0
3319DC00102	H4M17		19880307	1020	HRI	6.10	20.0	99	19	0.9	4	4	13	36	9	0.2	0.0
3319DC00102	H4M17		19880314	0945	HRI	6.00	23.5	115	25	1.3	5	5	11	45	13	0.1	0.0
3319DC00102	H4M17		19880321	1012	HRI	6.20	24.6	119	26	1.2	5	5	11	46	16	0.1	0.0
3319DC00102	H4M17		19880329	0945	HRI	6.10	22.4	109	23	1.1	5	5	9	42	13	0.1	0.0
3319DC00102	H4M17		19880404	1000	HRI	6.10	22.8	113	25	1.0	5	5	12	42	13	0.0	0.0
3319DC00102	H4M17		19880411	1035	HRI	5.90-	20.8	101	21	1.6	5	4	9	37	12	0.1	0.2
3319DC00102	H4M17		19880418	1029	HRI	5.90-	22.2	104	24	1.3	5	5	9	38	13	0.1	0.0
3319DC00102	H4M17		19880425	1040	HRI	5.40v	13.7	66	13	1.4	5	3	6	24	7	0.0	0.2
3319DC00102	H4M17		19880502	1130	HRI	5.50-	23.2	111	25	1.4	5	5	6	46	16	0.1	0.2

Site id	# on map	Sample #	Date	Time	Lab.	pH	EC mS/m	TDS () mg/L	Na mg/L	K mg/L	Ca mg/L	Mg mg/L	M. Alk mg/L	Cl mg/L	SO4 mg/L	F mg/L	NO3-N mg/L
3319DC00102	H4M17		19880509	1000	HRI	6.00	31.8	158	36	1.6	8	7	10	60	27	0.1	0.1
3319DC00102	H4M17		19880516	1034	HRI	6.80	37.6	213	43	1.8	9	9	21	79	37	0.3	0.1
3319DC00102	H4M17		19880523	1018	HRI	4.80v	11.2	58	11	1.3	3	2	7	20	5	0.1	0.1
3319DC00102	H4M17		19880530	1115	HRI	4.60v	9.7	56	9	1.0	2	2	11	17	5	0.1	0.2
3319DC00102	H4M17		19880606	1038	HRI	4.40v	7.9	41	7	1.4	2	2	5	13	4	0.1	0.3
3319DC00102	H4M17		19880613	1015	HRI	5.40v	15.1	83	16	1.4	4	4	10	28	9	0.1	0.8
3319DC00102	H4M17		19880620	1120	HRI	5.70-	17.5	95	19	1.4	5	4	12	31	12	0.1	0.8
3319DC00102	H4M17		19880627	0935	HRI	5.90-	23.6	117	24	1.4	6	6	12	40	18	0.1	0.8
3319DC00102	H4M17		19880704	1045	HRI	6.50	33.4	171	36	2.1	9	8	20	57	29	0.1	0.9
3319DC00102	H4M17		19880711	1045	HRI	4.80v	7.5	40	7	1.0	2	2	8	12	3	0.2	0.2
3319DC00102	H4M17		19880718	1000	HRI	6.10	20.9	97	21	1.4	5	5	8	35	15	0.1	0.7
3319DC00102	H4M17		19880725	1025	HRI	5.70-	12.8	62	14	1.1	3	3	6	22	7	0.1	0.4
3319DC00102	H4M17		19880801	1110	HRI	6.70	28.8	141	29	1.3	7	7	18	47	21	0.4	0.7
3319DC00102	H4M17		19880808	1010	HRI	6.50	37.4	208	44	2.0	10	9	25	71	36	0.2	0.8
3319DC00102	H4M17		19880815	1013	HRI	6.10	25.8	124	26	1.6	6	6	15	42	20	0.2	0.5
3319DC00102	H4M17		19880822	1025	HRI	6.50	37.2	191	40	1.8	9	9	20	67	33	0.1	0.6
3319DC00102	H4M17		19880829	1050	HRI	6.40	42.2	224	46	2.1	10	11	28	80	37	0.0	0.7
3319DC00102	H4M17		19880905	1040	HRI	5.00v	15.3	80	14	1.1	5	4	13	27	9	0.2	0.5
3319DC00102	H4M17		19880912	1010	HRI	3.60v	8.4	34	7	0.6	2	2	4	13	2	0.1	0.2
3319DC00102	H4M17		19880919	1300	HRI	4.40v	10.8	45	10	0.6	3	2	3	18	5	0.1	0.2
3319DC00102	H4M17		19880926	1044	HRI	5.60-	21.6	95	18	0.9	5	5	12	35	12	0.1	0.4
3319DC00102	H4M17		19881003	1040	HRI	5.70-	15.4	80	14	0.8	4	4	11	30	10	0.1	0.3
3319DC00102	H4M17		19881010	1035	HRI	6.20	23.4	121	23	0.9	6	6	12	46	21	0.0	0.4
3319DC00102	H4M17		19881017	1030	HRI	6.30	30.8	162	32	1.3	8	8	17	61	27	0.1	0.4
3319DC00102	H4M17		19881024	1002	HRI	6.60	41.0	214	44	1.3	10	11	26	76	35	0.3	0.3
3319DC00102	H4M17		19881025	0900	HRI 13	6.70	40.0	192	42	1.4	10	11	22	70	30	0.7<	0.0
3319DC00102	H4M17		19881031	1050	HRI	6.40	37.1	189	38	1.3	8	10	22	67	32	0.1	0.4
3319DC00102	H4M17		19881107	0952	HRI	5.90-	24.7	111	23	0.9	5	5	12	43	14	0.5	0.2
3319DC00102	H4M17		19881114	1110	HRI	6.20	34.0	172	35	0.9	8	8	20	63	28	0.2	0.1
3319DC00102	H4M17		19881121	1040	HRI	6.20	31.7	150	32	1.3	6	7	17	57	19	0.3	0.1
3319DC00102	H4M17		19881128	1126	HRI	6.00	19.0	113	26	1.2	5	6	9	44	14	0.1	0.0
3319DC00102	H4M17		19881205	1049	HRI	6.00	19.0	110	27	1.1	5	5	8	43	14	0.1	0.0
3319DC00102	H4M17		19881212	1100	HRI	6.20	25.0	113	25	1.0	4	5	11	44	16	0.5	0.0
3319DC00102	H4M17		19881219	1200	HRI	5.80-	17.6	100	24	1.2	4	5	8	39	11	0.0	0.0
3319DC00102	H4M17		19881226	0930	HRI	6.10	22.9	105	23	1.2	3	5	11	39	13	0.2	0.0
3319DC00102	H4M17		19890102	0948	HRI	6.00	16.6	94	17	0.8	4	4	16	32	8	0.4	0.0
3319DC00102	H4M17		19890109	1030	HRI	6.00	16.6	82	16	0.7	4	4	11	30	7	0.1	0.0
3319DC00102	H4M17		19890116	1050	HRI	6.10	17.2	87	16	0.7	4	4	11	32	7	0.1	0.0
3319DC00102	H4M17		19890123	1050	HRI	6.00	14.0	71	16	1.1	3	3	5	29	6	0.1	0.0
3319DC00102	H4M17		19890130	1105	HRI	6.00	15.9	73	17	1.0	3	3	6	30	5	0.1	0.0
3319DC00102	H4M17		19890206	1100	HRI	7.40	14.0	79	16	0.9	3	3	14	30	1	0.1	0.0
3319DC00102	H4M17		19890213	1042	HRI	7.00	13.6	86	16	1.0	3	3	12	28	10	0.1	0.0
3319DC00102	H4M17		19890220	1110	HRI	6.80	14.9	88	18	1.2	3	4	12	30	10	0.1	0.0
3319DC00102	H4M17		19890227	1105	HRI	6.70	13.7	83	16	1.0	3	3	12	29	8	0.1	0.0
3319DC00102	H4M17		19890306	1102	HRI	6.50	13.7	83	15	1.4	3	3	12	28	10	0.1	0.1
3319DC00102	H4M17		19890313	1122	HRI	7.50	16.5	92	20	1.1	4	4	10	34	12	0.1	0.0
3319DC00102	H4M17		19890320	0950	HRI	7.10	17.2	93	20	1.4	4	4	8	39	10	0.0	0.0
3319DC00102	H4M17		19890327	1205	HRI	7.10	21.8	114	26	1.1	5	5	11	43	16	0.0	0.0

157

Site id	# on map	Sample #	Date	Time	Lab.	pH	EC mS/m	TDS () mg/L	Na mg/L	K mg/L	Ca mg/L	Mg mg/L	M.Alk mg/L	Cl mg/L	SO4 mg/L	F mg/L	NO3-N mg/L
3319DC00102	H4M17		19890403	1140	HRI	6.60	9.6	51	11	1.2	3	2	5	18	4	0.0	0.0
3319DC00102	H4M17		19890410	1050	HRI	6.80	22.4	126	29	1.4	6	6	11	48	16	0.0	0.0
3319DC00102	H4M17		19890417	1110	HRI	7.10	23.8	133	28	1.2	5	6	17	51	16	0.2	0.0
3319DC00102	H4M17		19890424	1100	HRI	6.80	22.9	125	27	2.7	5	5	16	45	14	0.1	0.2
3319DC00102	H4M17		19890426	1130	HRI 89617629	6.50	29.0	170	27	2.1	16	6	52	39	14	0.3	0.0
3319DC00102	H4M17		19890501	1035	HRI	7.20	40.9	236	51	2.3	10	10	28	88	34	0.1	0.3
3319DC00102	H4M17		19890508	1100	HRI	7.40	47.6	284	56	3.3	14	13	36	99	46	0.1	0.4
3319DC00102	H4M17		19890515	1025	HRI	6.40	10.2	63	11	1.1	3	3	10	20	5	0.1	0.1
3319DC00102	H4M17		19890522	1010	HRI	6.10	17.1	98	20	1.2	5	4	12	33	11	0.2	0.2
3319DC00102	H4M17		19890529	1100	HRI	7.90	27.2	151	33	1.3	7	7	18	54	20	0.1	0.3
3319DC00102	H4M17		19890605	1132	HRI	7.60	11.5	70	14	1.0	4	3	11	22	6	0.2	0.2
3319DC00102	H4M17		19890612	1055	HRI	7.70	24.2	134	29	2.1	6	6	16	48	16	0.1	0.5
3319DC00102	H4M17		19890619	1100	HRI	7.80	36.0	206	45	2.5	9	10	26	73	28	0.3	0.5
3319DC00102	H4M17		19890626	1045	HRI	7.70	27.4	158	34	4.2	7	7	24	54	17	0.1	0.4
3319DC00102	H4M17		19890703	1046	HRI	7.50	17.1	99	20	1.8	5	4	14	32	14	0.1	0.6
3319DC00102	H4M17		19890710	1120	HRI	7.30	17.2	100	19	1.7	5	5	12	34	16	0.1	0.6
3319DC00102	H4M17		19890717	1112	HRI	7.40	22.0	123	24	1.9	7	6	18	40	18	0.1	0.7
3319DC00102	H4M17		19890724	1150	HRI	7.20	19.1	109	21	1.8	5	5	14	37	17	0.0	0.7
3319DC00102	H4M17		19890731	1137	HRI	7.00	20.3	117	23	1.7	5	5	16	38	18	0.2	0.7
3319DC00102	H4M17		19890807	1120	HRI	7.40	20.6	108	21	1.9	5	5	15	39	13	0.1	0.7
3319DC00102	H4M17		19890814	1030	HRI	7.20	25.5	130	25	2.0	6	7	17	46	17	0.1	0.8
3319DC00102	H4M17		19890821	1115	HRI	7.10	15.3	73	14	1.3	4	4	11	26	7	0.1	0.5
3319DC00102	H4M17		19890828	1120	HRI	6.90	10.6	52	10	0.9	3	3	7	18	5	0.0	0.3
3319DC00102	H4M17		19890904	1138	HRI	6.90	17.2	81	16	1.5	4	4	11	30	8	0.0	0.7
3319DC00102	H4M17	H4M17	19900601	1715	IGS LECHASSEUR	7.26	27.0	183	39	2.0	11	8	17	60	32	0.4	1.5
3319DC00102	H4M17	H4M17	19900621	1518	IGS (H4M17)	6.71	32.0	226	51	2.9	13	11	27	73	33	0.3	1.2
3319DC00102	H4M17	H4M17	19900723	0000	IGS	6.72	22.0	167	36	1.8	10	8	21	50	27	0.4	1.2
3319DC00102	H4M17	H4M17	19900900	0000	IGS	6.53	35.0	251	53	1.0	25	11	30	82	36	0.4	1.0
3319DC00102	H4M17	LE CHASS	19900905	1540	IGS	7.15	27.0	179	35	1.6	11	9	25	60	26	0.3	0.9
3319DC00102	H4M17	H4M17	19901025	1508	IGS	6.80	32.0	222	46	1.3	11	10	28	80	32	0.4	0.7
3319DC00102	H4M17	LE CHASS	19901127	1027	IGS	6.62	25.0	172	38	0.9	9	7	22	59	28	0.0	0.4
3319DC00102	H4M17	LE CHASS	19901205	0800	IGS	6.64	23.0	163	35	0.1	10	7	22	56	25	0.7	0.4
3319DC00102	H4M17	LE CHASS	19901218	1449	IGS	6.49	19.0	134	29	0.7	8	6	17	46	20	0.0	0.5
3319DC00102	H4M17	LE CHASS	19910122	1510	IGS	6.40	12.0	101	23	1.0	7	4	13	32	16	0.0	0.4
3319DC00102	H4M17	LE CHASS	19910213	0000	IGS	6.73	19.0	128	27	1.5	8	5	14	45	21	0.3	0.4
3319DC00102	H4M17	LE CHASS	19910302	1100	IGS	6.63	18.0	160	31	0.9	7	5	36	44	19	0.1	2.0
3319DC00102	H4M17	LE CHASS	19910319	0000	IGS	6.66	17.0	142	39	1.5	8	7	29	38	13	0.0	0.1
3319DC00102	H4M17	LE CHASS	19910423	0000	IGS	7.40	22.0	191	45	2.1	30	9	31	50	16	0.2	0.1
3319DC00104	B7		19891025	1545	HRI 18	5.80-	16.0	76	15	3.3	3	3	11	29	3	0.7<	0.0
3319DC00104	B7		19890426	1215	HRI 89617678	6.10	47.0	285	43	7.8	22	9	50	77	47	0.2	0.0
3319DC00107	AB	AB	19900607	1045	IGS (AB)	7.47	534.0^	3579	776^	4.6	173+	188^	415	1693^	224+	0.9	0.7
3319DC00107	AB	AB	19900905	1515	IGS	7.61	531.0^	3745	863^	4.9	182+	199^	416	1717^	257+	1.6^	0.4
3319DC00107	AB	AB	19901205	0830	IGS	7.19	546.0^	3650	818^	2.3	181+	192^	412	1662^	258+	4.5^	4.0
3319DC00107	AB	AB	19910302	1200	IGS	8.00	566.0^	3737	861^	6.0	184+	193^	411	1706^	262+	5.3^	2.1
3319DC00108	U	U	19900602	0000	IGS (U)	6.01	13.0	109	22	4.3	7	3	15	36	7	0.6	0.4
3319DC00108	U	U	19900905	1200	IGS	6.49	15.0	116	22	4.8	6	4	15	38	11	0.4	0.4
3319DC00108	U	U	19901205	1335	IGS	5.60-	14.0	119	23	4.3	8	4	15	37	12	0.2	0.5
3319DC00108	U	U	19910227	1305	IGS	5.75-	14.0	108	19	4.2	5	3	16	38	7	0.4	0.4

158

159

Site id	# on map	Sample #	Date	Time	Lab.	pH	EC mS/m	TDS () mg/L	Na mg/L	K mg/L	Ca mg/L	Mg mg/L	M. Alk mg/L	Cl mg/L	SO4 mg/L	F mg/L	NO3-N mg/L
3319DC00109	T	T	19900602	0000	IGS (T)	6.37	27.0	204	41	6.8	12	6	25	69	21	0.4	0.4
3319DC00110	Y	Y	19900604	1230	IGS (Y)	6.53	43.0	305	76	7.8	6	8	13	118	43	0.4	0.4
3319DC00110	Y	Y	19900907	1615	IGS	6.40	40.0	282	67	6.8	6	7	29	99	29	0.3	0.3
3319DC00110	Y	Y	19901206	1220	IGS	5.94-	33.0	255	60	6.5	8	5	26	84	28	0.1	0.3
3319DC00110	Y	Y	19910305	1015	IGS	5.85-	44.0	306	77	6.3	6	7	22	110	39	0.3	1.0
3319DC00111	X	X	19900604	1130	IGS (X)	7.85	88.0+	687	107+	8.4	44	33	202	131	104	0.3	0.4
3319DC00111	X	X	19900907	1400	IGS	8.22	94.0+	763	128+	8.5	50	34	230	145	95	0.3	0.4
3319DC00111	X	X	19901206	1410	IGS	7.86	63.0	526	91	7.2	31	20	176	98	45	0.3	0.3
3319DC00111	X	X	19910305	1410	IGS	7.05	224.0+	1505	270+	13.7	109	65	159	511+	317+	1.7+	1.7
3319DC00112	DN06A	DN6A	19900601	1430	IGS (DN6A)	5.66-	14.0	100	24	2.0	4	3	9	42	4	0.5	0.5
3319DC00113	LEC01	LEC01	19900621	1501	IGS (LEC01)	6.73	19.0	146	32	2.5	10	7	18	42	21	0.4	1.3
3319DC00113	LEC01	LEC01	19900723	0000	IGS	6.71	18.0	139	29	1.6	10	6	16	42	20	0.4	1.3
3319DC00113	LEC01	LEC01	19900900	0000	IGS	6.52	17.0	121	26	0.5	8	6	15	40	15	0.4	1.1
3319DC00113	LEC01	LEC01	19901025	1429	IGS	6.10	8.0	79	25	0.8	5	4	7	24	7	0.7	0.6
3319DC00113	LEC01	LEC01	19901127	1012	IGS	6.06	8.0	67	18	0.6	5	2	7	22	7	0.0	0.4
3319DC00113	LEC01	LEC01	19901218	1437	IGS	6.18	8.0	66	15	0.9	5	3	8	22	7	0.4	0.4
3319DC00113	LEC01	LEC01	19910122	1510	IGS	6.28	6.0	68	18	1.3	5	3	7	19	10	0.2	0.4
3319DC00113	LEC01	LEC01	19910213	0000	IGS	6.20	8.0	96	21	0.6	5	3	7	23	11	5.0+	4.0
3319DC00113	LEC01	LEC01	19910319	0000	IGS	7.19	9.0	144	17	0.4	5	3	80	16	3	0.1	0.3
3319DC00113	LEC01	LEC01	19910423	0000	IGS	6.33	12.0	105	26	1.1	7	4	27	25	8	0.1	0.2
3319DC00114	LEC02	LEC02	19900621	1628	IGS (LEC02)	7.38	26.0	192	47	2.4	12	10	19	64	25	0.4	1.3
3319DC00115	O	O	19900601	1610	IGS (O)	6.39	8.0	70	21	1.0	5	2	4	24	7	0.5	0.4
3319DC00116	RY14	RY14	19900900	0000	IGS	6.94	208.0+	1436	315+	10.2	68	57	171	453+	308+	0.7	0.3
3319DC00116	RY14	RY14	19900907	1430	IGS	7.30	264.0+	2141	275+	17.1	160+	159+	192	309+	970+	2.2+	0.2
3319DC00118	DN07B	DN7B	19900905	1110	IGS	7.37	196.0+	1502	306+	2.1	78	69	313	396+	250+	0.8	0.3
3319DD00001	G33570	G33570	19900608	1415	IGS (AK)	9.19+	682.0+	4209	1423+	46.3	19	88+	75	2428+	120	1.3+	0.3
3319DD00001	G33570	G33570	19900620	0000	IGS (G33570)	8.94	667.0+	4170	1420+	48.2	22	91+	75	2366+	142	0.7	0.3
3319DD00001	G33570	G33570	19900727	0000	IGS	8.69	667.0+	4450	1507+	48.0	20	94+	80	2524+	163	1.6+	0.2
3319DD00001	G33570	G33570	19901200	0000	IGS	7.36	99.0+	866	193+	2.2	17	8	436	99	5	0.9	0.3
3319DD00001	G33570	G33570	19910131	0000	IGS	7.31	692.0+	4170	1490+	43.9	17	78+	74	2318+	129	2.6+	0.2
3319DD00001	G33570	G33570	19910305	0000	IGS	8.63	663.0+	4132	1277+	46.0	16	119+	341	1978+	299+	0.7	0.1
3319DD00001	G33570	G33570	19910426	0000	IGS	8.85	660.0+	4069	1286+	46.0	11	111+	339	1954+	278+	0.8	0.2
3319DD00003	G33571A	G33571A	19900620	0000	IGS (G33571A)	7.83	2210.0+	15125+	4070+	114.3	493+	667+	399	8571+	704+	6.9+	0.2
3319DD00003	G33571A	G33571A	19900727	0000	IGS	7.49	1788.0+	15939+	4264+	133.5	482+	713+	433	8906+	892+	6.5+	0.0
3319DD00003	G33571A	G33571A	19901000	0000	IGS	7.09	2240.0+	15499+	4327+	110.0	499+	662+	395	8584+	811+	11.8+	0.4
3319DD00003	G33571A	G33571A	19901200	0000	IGS	7.35	2260.0+	16119+	4239+	118.7	521+	670+	393	9209+	858+	15.0+	
3319DD00003	G33571A	G33571A	19910131	0000	IGS	7.30	2250.0+	15403+	4282+	120.5	486+	673+	392	8449+	894+	10.1+	0.4
3319DD00004	G33572	G33572	19900620	0000	IGS (G33572)	8.91	280.0+	1665	566+	8.6	14	25	133	860+	40	0.7	0.3
3319DD00004	G33572	G33572	19900727	0000	IGS	8.60	275.0+	1449	599+	9.7	15	26	120	615+	41	0.5	0.3
3319DD00004	G33572	G33572	19900900	0000	IGS	8.20	280.0+	1641	540+	8.7	17	23	101	889+	30	1.5+	0.4
3319DD00004	G33572	G33572	19901000	0000	IGS	8.13	275.0+	1810	616+	10.2	22	24	110	971+	27	2.9+	0.5
3319DD00004	G33572	G33572	19901200	0000	IGS	8.10	275.0+	1582	556+	8.9	17	23	100	834+	17	1.1+	0.4
3319DD00004	G33572	G33572	19910131	0000	IGS	8.08	277.0+	1572	571+	9.0	16	22	89	831+	12	0.6	0.1
3319DD00004	G33572	G33572	19910305	0000	IGS	8.36	560.0+	3391	951+	35.0	88	102+	240	1688+	237+	0.9	0.4
3319DD00004	G33572	G33572	19910426	0000	IGS	8.39	561.0+	3436	993+	36.0	85	103+	242	1698+	230+	0.9	0.2
3319DD00005	G33573	G33573	19900620	0000	IGS (G33573)	8.51	339.0+	3628	1220+	25.7	16	62	238	1790+	229+	1.7+	0.3
3319DD00005	G33573	G33573	19900727	0000	IGS	7.41	531.0+	3828	1355+	27.5	26	71+	221	1784+	287+	4.7+	0.2
3319DD00005	G33573	G33573	19901200	0000	IGS	8.87	1525.0+	10155+	3318+	99.1	12	250+	377	5581+	462+	9.6+	2.6

Site id	# on map	Sample #	Date	Time	Lab.	pH	EC mS/m	TDS () mg/L	Na mg/L	K mg/L	Ca mg/L	Mg mg/L	M.Alk mg/L	Cl mg/L	SO4 mg/L	F mg/L	NO3-N mg/L
3319DD00005	G33573	G33573	19910131	0000	IGS	8.29	592.0^	3889	1284^	24.2	17	61	233	1930^	254+	3.9^	6.8+
3319DD00005	G33573	G33573	19910305	0000	IGS	7.18	44.0	324	85	3.3	11	11	67	112	16	0.1	0.9
3319DD00005	G33573	G33573	19910426	0000	IGS	7.68	39.0	326	63	2.1	10	9	109	97	10	0.1	0.3
3319DD00006	G33574	G33574	19900620	0000	IGS (G33574)	8.81	1150.0^	7767	2267^	61.8	33	353^	78	4750^	216+	3.6^	0.1
3319DD00007	G33575	G33575	19900620	0000	IGS (G33575)	8.86	457.0^	2943	945^	17.6	12	68	218	1521^	120	3.5^	0.3
3319DD00007	G33575	G33575	19910305	0000	IGS	8.03	274.0+	1592	548^	9.3	17	23	88	882^	4	0.5	0.2
3319DD00007	G33575	G33575	19910426	0000	IGS	7.92	271.0+	1640	574^	9.0	26	28	101	877^	2	0.5	0.1
3319DD00008	G33576	G33576	19900620	0000	IGS (G33576)	6.74	595.0^	3676	1177^	18.1	68	98+	25	2269^	11	1.6^	0.3
3319DD00008	G33576	G33576	19900727	0000	IGS	6.96	570.0^	3676	1199^	18.1	72	104^	24	2230^	20	0.9	0.2
3319DD00008	G33576	G33576	19901200	0000	IGS	6.38	612.0^	3511	1208^	17.7	75	91+	16	2086^	9	1.8^	0.2
3319DD00008	G33576	G33576	19910131	0000	IGS	6.52	612.0^	3594	1221^	18.2	74	89+	20	2152^	11	3.5^	0.1
3319DD00008	G33576	G33576	19910305	0000	IGS	8.17	365.0^	2148	640^	14.6	53	61	112	1144^	97	0.2	0.3
3319DD00008	G33576	G33576	19910426	0000	IGS	8.17	365.0^	2170	673^	16.7	51	63	112	1132^	96	0.2	0.2
3319DD00009	G33577	G33577	19900619	0000	IGS (G33577)	8.58	1376.0^	8790	2591^	22.3	42	459^	103	5138^	424+	3.6^	0.1
3319DD00009	G33577	G33577	19900724	0000	IGS	8.25	991.0^	9035	2658^	23.3	45	485^	90	5199^	505+	7.3^	0.2
3319DD00009	G33577	G33577	19900900	0000	IGS	7.85	1420.0^	9082	2535^	14.2	44	443^	81	5461^	481+	1.8^	0.5
3319DD00009	G33577	G33577	19901000	0000	IGS	7.91	1411.0^	9635	2662^	20.6	67	457^	93	5849^	456+	6.0^	0.8
3319DD00009	G33577	G33577	19901200	0000	IGS	7.01	141.0+	748	214+	2.7	20	31	39	421+	8	0.6	0.3
3319DD00009	G33577	G33577	19910131	0000	IGS	7.06	134.0+	747	208+	3.4	22	33	32	430+	9	0.8	0.3
3319DD00009	G33577	G33577	19910228	0000	IGS	7.83	689.0^	4502	1118^	12.9	165+	160^	579	1990^	347+	0.4	0.6
3319DD00009	G33577	G33577	19910425	0000	IGS	8.16	690.0^	4543	1160^	15.4	161+	156^	574	2009^	339+	0.2	0.6
3319DD00014	G33582	G33582	19900620	0000	IGS (G33582)	4.30v	2620.0^	18826^	4921^	114.3	629^	907^	0	11120^	1052^	13.4^	0.1
3319DD00014	G33582	G33582	19900727	0000	IGS	4.17v	2590.0^	19885^	5315^	133.9	636^	931^	0	11585^	1195^	17.0^	0.0
3319DD00014	G33582	G33582	19900900	0000	IGS	4.06v	2610.0^	19042^	4922^	131.8	628^	841^	0	11312^	1167^	0.8	0.0
3319DD00014	G33582	G33582	19901000	0000	IGS	3.44v	2630.0^	19663^	5070^	124.7	636^	487^	0	12289^	1006^	30.0^	0.0
3319DD00014	G33582	G33582	19901200	0000	IGS	8.22	214.0+	1572	379+	14.1	65	58	368	473+	121	2.3^	0.4
3319DD00014	G33582	G33582	19910131	0000	IGS	3.40v	2670.0^	18368^	5074^	130.3	596^	827^	0	10759^	945^	15.8^	0.2
3319DD00014	G33582	G33582	19910305	0000	IGS	8.91	1508.0^	10695^	3569^	104.0	231^	452^	375	5491^	434+	0.7	0.0
3319DD00014	G33582	G33582	19910426	0000	IGS	8.95	1500.0^	9521	2960^	89.7	11	215^	354	5440^	412+	0.7	0.0
3319DD00015	G33583	G33583	19900620	0000	IGS (G33583)	8.55	1427.0^	9795	3093^	96.8	23	260^	390	5468^	392+	5.2^	0.3
3319DD00015	G33583	G33583	19900727	0000	IGS	8.66	1157.0^	10124^	3487^	106.3	20	266^	371	5390^	414+	10.0^	0.5
3319DD00015	G33583	G33583	19901200	0000	IGS	7.23	1812.0^	12844^	4157^	20.9	88	319^	133	7239^	827^	11.6^	3.1
3319DD00015	G33583	G33583	19910131	0000	IGS	8.50	1523.0^	10434^	3348^	102.4	14	250^	353	5798^	478+	7.2^	5.0
3319DD00015	G33583	G33583	19910305	0000	IGS	8.32	1132.0^	7060	2218^	60.3	26	167^	228	3759^	548+	1.1+	0.5
3319DD00015	G33583	G33583	19910426	0000	IGS	8.43	1111.0^	6826	2118^	60.1	26	165^	224	3659^	532+	1.1+	0.2
3319DD00016	G33584	G33584	19900620	0000	IGS (G33584)	8.40	1065.0^	7168	2364^	64.2	28	184^	237	3711^	529+	2.8^	0.1
3319DD00016	G33584	G33584	19900727	0000	IGS	8.46	933.0^	7302	2401^	59.7	25	190^	218	3745^	611^	3.0^	0.1
3319DD00016	G33584	G33584	19900900	0000	IGS	8.38	1092.0^	7166	2239^	56.8	22	169^	217	3832^	581+	3.0^	0.8
3319DD00016	G33584	G33584	19901000	0000	IGS	8.46	1119.0^	7702	2389^	69.0	24	178^	221	4199^	575+	3.4^	0.6
3319DD00016	G33584	G33584	19901200	0000	IGS	8.30	637.0^	4986	1486^	19.7	32	86+	1098	1491^	514+	5.5^	0.5
3319DD00016	G33584	G33584	19910131	0000	IGS	8.41	1110.0^	7683	2399^	67.5	25	173^	229	4055^	562+	4.4^	28.3^
3319DD00016	G33584	G33584	19910305	0000	IGS	8.02	631.0^	3738	1179^	25.3	16	60	166	1974^	279+	0.6	0.2
3319DD00016	G33584	G33584	19910426	0000	IGS	8.20	624.0^	3792	1152^	38.4	57	108^	168	1946^	283+	0.6	0.5
3319DD00020	G33588	G33588	19900619	0000	IGS (G33588)	7.50	1734.0^	12555^	3671^	64.1	216^	443^	545	6186^	1292^	6.0^	1.0
3319DD00020	G33588	G33588	19900724	0000	IGS	7.47	1132.0^	12259^	3677^	69.0	262^	416^	558	5752^	1373^	11.7^	1.3
3319DD00020	G33588	G33588	19901200	0000	IGS	7.31	253.0+	6310	3531^	64.0	173+	359^	203	623^	1297^	0.7	1.6
3319DD00020	G33588	G33588	19910131	0000	IGS	7.26	261.0+	1732	360+	5.1	99	81+	204	734^	174	16.2^	1.6
3319DD00020	G33588	G33588	19910228	0000	IGS	8.93	894.0^	5931	1813^	20.0	16	187^	628	2641^	549+	1.5+	0.2

160

Site id	# on map	Sample #	Date	Time	Lab.	pH	EC mS/m	TDS () mg/L	Na mg/L	K mg/L	Ca mg/L	Hg mg/L	M.Alk mg/L	Cl mg/L	SO4 mg/L	F mg/L	NO3-N mg/L
3319DD00020	G33588	G33588	19910425	0000	IGS	9.08+	873.0^	5693	1725^	20.0	11	162^	657	2528^	530+	1.4+	0.2
3319DD00021	G33589	G33589	19900619	0000	IGS (G33589)	7.31	676.0^	4434	1176^	27.3	141	167^	478	1986^	340+	1.7^	0.6
3319DD00021	G33589	G33589	19900724	0000	IGS	7.52	565.0^	4791	1337^	20.5	178+	183^	588	1948^	392+	1.6^	0.6
3319DD00021	G33589	G33589	19901200	0000	IGS	7.59	148.0+	643	170+	1.8	46	60	92	244	5	0.7	0.2
3319DD00021	G33589	G33589	19910131	0000	IGS	7.52	140.0+	761	170+	2.5	28	57	60	421+	6	0.8	0.3
3319DD00021	G33589	G33589	19910228	0000	IGS	3.35v	2650.0^	17667^	4329^	119.0	566^	799^	0	11009^	845^	0.3	0.0
3319DD00021	G33589	G33589	19910426	0000	IGS	6.50	2640.0^	17712^	4350^	123.7	564^	818^	11	11004^	839^	0.7	0.0
3319DD00022	G33590	G33590	19900620	0000	IGS (G33590)	8.73	102.0+	674	221+	3.5	7	5	111	315+	9	0.3	0.3
3319DD00022	G33590	G33590	19900727	0000	IGS	7.86	108.0+	687	227+	3.3	7	6	88	310+	20	0.3	0.9
3319DD00022	G33590	G33590	19900900	0000	IGS	7.57	117.0+	748	248+	3.0	7	7	95	330+	33	0.1	0.7
3319DD00022	G33590	G33590	19901000	0000	IGS	7.58	108.0+	744	248+	3.4	8	7	93	321+	38	0.4	0.7
3319DD00022	G33590	G33590	19901200	0000	IGS	7.56	640.0^	4041	1246^	42.4	97	111^	173	2003^	305+	14.7^	0.9
3319DD00022	G33590	G33590	19910131	0000	IGS	6.67	41.0	281	78	3.4	12	10	35	105	27	0.1	0.4
3319DD00022	G33590	G33590	19910305	0000	IGS	8.00	79.0+	906	178+	3.9	21	17	458	125	1	0.7	0.1
3319DD00022	G33590	G33590	19910426	0000	IGS	8.00	67.0	479	97	2.6	13	13	188	118	6	0.3	0.1
3319DD00024	G33592	G33592	19900620	0000	IGS (G33592)	7.96	60.0	515	139+	2.1	9	8	202	103	5	0.0	0.0
3319DD00024	G33592	G33592	19900727	0000	IGS	8.01	63.0	557	168+	3.1	8	8	210	99	8	0.4	0.2
3319DD00024	G33592	G33592	19901200	0000	IGS	7.94	608.0^	3836	1204^	25.5	17	59	248	1879^	262+	3.9^	0.4
3319DD00024	G33592	G33592	19910131	0000	IGS	7.15	88.0+	769	187+	3.0	15	9	355	105	6	0.6	0.3
3319DD00024	G33592	G33592	19910305	0000	IGS	8.02	238.0+	1464	389+	17.0	39	66	136	642^	141	0.4	0.8
3319DD00024	G33592	G33592	19910426	0000	IGS	8.15	239.0+	1443	382+	17.0	36	65	137	636^	139	0.4	0.2
3319DD00029	BI02	BI2	19900606	1400	IGS (BI2)	6.85	16.0	154	18	9.1	10	4	52	22	9	0.7	0.4
3319DD00029	BI02	BI2	19900904	1130	IGS	6.89	17.0	153	18	9.4	12	4	51	24	8	0.6	0.3
3319DD00029	BI02	BI1	19901204	1100	IGS	6.60	17.0	157	17	7.8	12	4	57	23	7	0.4	0.3
3319DD00029	BI02	BI2	19910228	1130	IGS	6.83	18.0	151	16	8.2	10	4	52	27	6	0.3	0.3
3319DD00033	GE01	GE1	19900605	0000	IGS (GE1)	7.36	30.0	256	27	6.6	25	11	89	45	14	0.3	0.3
3319DD00033	GE01	GE1	19900906	1630	IGS	7.12	34.0	281	29	6.3	27	12	96	52	19	0.5	0.3
3319DD00033	GE01	GE01	19901207	1330	IGS	6.91	32.0	302	30	6.3	30	11	108	52	21	0.3	0.3
3319DD00033	GE01	GE1	19910226	1530	IGS	6.81	33.0	303	28	5.5	27	11	117	49	21	0.2	0.2
3319DD00035	KR01	KR1	19900608	1240	IGS (KR1)	5.84-	26.0	180	39	0.5	3	6	13	80	7	0.4	0.6
3319DD00035	KR01	KR1	19900906	1500	IGS	5.66-	24.0	148	37	1.2	4	5	9	73	7	0.4	0.9
3319DD00035	KR01	KR01	19901206	0950	IGS	6.27	18.0	123	20	0.0	7	2	25	50	8	0.3	0.4
3319DD00035	KR01	KR1	19910304	1700	IGS	6.24	26.0	186	38	2.8	8	6	30	71	8	0.3	0.8
3319DD00042	MD07	MD7	19890426	0930	HRI B9617721	7.20	169.0+	1137	259+	2.8	57	35	323	283+	95	1.0	0.0
3319DD00042	MD07	MD7	19900606	1130	IGS (MD7)	7.50	138.0+	1032	224+	2.0	51	27	297	282+	70	0.7	0.4
3319DD00042	MD07	MD7	19900904	1030	IGS	7.68	141.0+	1060	242+	2.6	52	29	294	280+	81	0.6	0.3
3319DD00042	MD07	MD7	19901204	1025	IGS	7.62	141.0+	1052	239+	1.0	55	28	288	282+	82	0.5	0.3
3319DD00042	MD07	MD7	19910228	1200	IGS	7.20	135.0+	998	218+	2.3	47	26	287	260+	80	1.4+	0.3
3319DD00043	MD08	MD8	19900606	1215	IGS (MD8)	7.68	163.0+	972	323+	2.7	18	10	33	567+	7	1.0	0.4
3319DD00043	MD08	MD8	19900904	1200	IGS	7.20	139.0+	979	214+	2.8	62	27	174	302+	141	1.2+	0.3
3319DD00043	MD08	MD8	19901204	1115	IGS	7.47	115.0+	800	207+	0.9	24	19	127	294+	96	1.1+	0.3
3319DD00043	MD08	MD8	19910228	1000	IGS	6.65	271.0+	1902	359+	3.4	147	66	242	664^	329+	2.0^	0.3
3319DD00045	DP04	DP4	19900609	0830	IGS (DP4)	7.95	26.0	236	26	1.4	29	8	79	34	29	0.4	0.4
3319DD00045	DP04	DP4	19900906	0930	IGS	8.09	35.0	292	22	0.9	27	8	125	35	27	0.5	0.3
3319DD00045	DP04	DP4	19901207	0830	IGS	7.24	36.0	301	26	1.7	43	11	107	36	41	0.2	0.2
3319DD00045	DP04	DP04	19910304	0845	IGS	8.45	35.0	304	29	1.5	40	12	109	32	41	0.3	2.0
3319DD00047	DP06	DP6	19900608	0000	IGS (DP6)	7.46	64.0	512	76	2.2	43	22	167	97	54	0.4	0.3
3319DD00047	DP06	DP6	19900907	0730	IGS	8.49	55.0	402	67	2.3	32	18	122	102	34	0.6	0.3

Site id	# on map	Sample #	Date	Time	Lab.	pH	EC mS/m	TDS () mg/L	Na mg/L	K mg/L	Ca mg/L	Mg mg/L	M.Alk mg/L	Cl mg/L	SO4 mg/L	F mg/L	NO3-N mg/L
3319DD00047	DP06	DP6	19901203	1300	IGS	7.09	83.0+	627	85	2.9	61	30	145	138	118	0.2	0.3
3319DD00047	DP06	DP6	19910304	1400	IGS	7.17	86.0+	601	85	3.6	58	29	137	153	94	0.6	0.4
3319DD00049	DP08	DP8	19900607	1500	IGS (DP8)	7.75	152.0+	1085	136+	5.7	123	37	280	334+	94	0.7	0.4
3319DD00050	DP09	DP9	19881026	0900	HRI 20	7.40	112.0+	709	131+	4.0	54	33	117	159	177	0.7<	0.0
3319DD00050	DP09	DP9	19890426	1400	HRI 89617691	6.30	121.0+	784	119+	3.7	65	38	185	176	146	0.4	0.0
3319DD00050	DP09	DP9	19900607	1345	IGS (DP9)	7.10	142.0+	1055	164+	53.1	81	49	190	214	182	0.5	14.9^
3319DD00050	DP09	DP9	19900907	0830	IGS	7.42	107.0+	773	120+	1.3	68	35	174	178	145	0.3	0.4
3319DD00050	DP09	DP9	19901206	0000	IGS	7.18	104.0+	804	132+	0.0	73	34	186	188	137	0.3	0.4
3319DD00050	DP09	DP9	19910304	1600	IGS	6.88	257.0+	1663	153+	174.1	85	44	236	391+	169	0.7	78.7^
3319DD00051	RE01	RE1	19881026	1130	HRI 22	7.90	142.0+	901	132+	2.5	118	24	248	233	80	0.6	0.0
3319DD00051	RE01	RE1	19890426	1340	HRI 89617710	7.00	121.0+	768	132+	3.9	66	24	235	248	4	0.5	0.0
3319DD00051	RE01	RE1	19900607	1530	IGS (RE1)	7.68	115.0+	866	127+	2.2	97	19	272	221	58	0.4	0.5
3319DD00051	RE01	RE1	19900906	1030	IGS	7.43	98.0+	802	112+	44.0	87	17	267	157	50	0.5	0.4
3319DD00051	RE01	RE1	19901203	1600	IGS	7.28	26.0	251	39	4.9	18	10	101	29	14	0.6	0.4
3319DD00051	RE01	RE1	19910304	1245	IGS	7.52	127.0+	902	129+	3.1	105	21	266	230	81	1.1+	0.3
3319DD00052	RE02	RE2	19881026	1140	HRI 21	7.80	58.0	409	48	10.1	28	21	205	25	11	1.0	0.0
3319DD00052	RE02	RE2	19890426	1400	HRI 89617708	7.10	41.0	300	51	5.9	18	8	140	34	8	1.3+	0.0
3319DD00052	RE02	RE2	19900607	0000	IGS (RE2)	8.18	37.0	346	52	7.2	22	13	163	35	8	0.7	0.4
3319DD00052	RE02	RE2	19900905	1015	IGS	8.16	38.0	351	47	9.0	22	14	158	32	17	1.1+	0.5
3319DD00052	RE02	RE2	19901203	1615	IGS	7.36	99.0+	781	110+	4.3	98	17	266	160	58	0.3	0.4
3319DD00053	RL01	RL1	19900606	1230	IGS (RL1)	7.06	55.0	409	87	7.2	18	13	99	117	29	0.4	0.4
3319DD00053	RL01	RL1	19900904	1230	IGS	6.97	93.0+	602	132+	10.5	26	19	92	229	59	0.5	0.3
3319DD00053	RL01	RL1	19901204	1130	IGS	6.60	184.0+	1160	284+	18.4	50	38	75	513+	137	0.3	0.2
3319DD00053	RL01	RL1	19910228	1030	IGS	6.55	178.0+	1137	268+	14.9	46	36	106	485+	128	1.2+	0.3
3319DD00054	TY01	TY1	19900606	1530	IGS (TY1)	5.96-	19.0	139	31	2.7	7	5	10	55	18	0.4	0.6
3319DD00054	TY01	TY1	19900904	1445	IGS	5.43v	19.0	125	31	2.6	4	4	6	62	5	0.4	0.4
3319DD00054	TY01	TY1	19901204	1400	IGS	5.37v	32.0	202	45	4.6	7	8	7	96	19	0.1	0.5
3319DD00054	TY01	TY1	19910228	0900	IGS	5.01v	18.0	122	30	2.8	4	4	6	58	7	0.1	0.4
3319DD00055	TY02	TY2	19900606	1500	IGS (TY2)	5.96-	28.0	183	45	5.1	6	7	5	85	16	0.3	0.5
3319DD00055	TY02	TY2	19900904	1415	IGS	4.13v	51.0	299	69	6.8	10	11	0	143	31	0.2	0.4
3319DD00055	TY02	TY2	19901204	1415	IGS	5.17v	20.0	137	33	1.7	4	5	7	61	13	0.2	0.3
3319DD00055	TY02	TY2	19910228	0910	IGS	5.00v	28.0	179	39	5.3	6	7	8	82	17	0.2	0.5
3319DD00057	TY04	TY4	19900606	1515	IGS (TY4)	5.31v	20.0	145	35	4.5	5	5	13	58	11	0.4	0.4
3319DD00057	TY04	TY4	19900904	1430	IGS	5.37v	23.0	153	38	4.5	4	6	4	70	15	0.3	0.3
3319DD00057	TY04	TY4	19901204	1430	IGS	5.06v	18.0	119	29	3.0	5	4	4	58	6	0.0	0.3
3319DD00057	TY04	TY4	19910228	0905	IGS	4.85v	18.0	123	28	3.1	4	4	4	57	10	1.0	0.6
3319DD00058	VD02	VD2	19900606	1000	IGS (VD2)	7.33	24.0	208	31	5.7	16	6	51	44	29	0.5	0.4
3319DD00058	VD02	VD2	19900904	0915	IGS	7.09	24.0	171	33	2.7	12	6	32	49	21	0.4	0.4
3319DD00058	VD02	VD2	19901204	0930	IGS	7.05	59.0	397	59	7.9	38	15	52	136	60	0.1	0.2
3319DD00058	VD02	VD2	19910228	1315	IGS	6.54	240.0+	1564	276+	13.5	120	68	84	652^	298+	2.5^	0.4
3319DD00059	VD03	VD3	19900606	1030	IGS (VD3)	6.77	15.0	156	18	6.3	12	4	53	19	13	0.7	0.4
3319DD00059	VD03	VD3	19900904	0845	IGS	6.78	14.0	149	15	6.0	13	4	53	16	8	0.6	0.3
3319DD00059	VD03	VD3	19901204	0920	IGS	7.16	119.0+	735	141+	3.4	72	23	161	185	96	0.3	0.3
3319DD00059	VD03	VD3	19910228	1250	IGS	6.80	80.0+	540	84	10.2	52	15	81	182	73	0.4	0.3
3319DD00060	VD04	VD4	19900606	1050	IGS (VD4)	7.76	264.0+	1977	436^	10.8	83	61	468	632^	167	0.4	0.7
3319DD00060	VD04	VD4	19900904	1000	IGS	7.78	274.0+	2062	478^	12.2	93	70	465	640^	186	0.8	0.5
3319DD00060	VD04	VD4	19901204	1500	IGS	7.72	287.0+	2138	494^	15.0	99	70	463	671^	206+	0.7	0.8
3319DD00060	VD04	VD4	19910228	1220	IGS	7.64	215.0+	1520	343+	8.5	68	49	327	485+	153	2.6^	0.6

Site id	# on map	Sample #	Date	Time	Lab.	pH	EC mS/m	TDS () mg/L	Na mg/L	K mg/L	Ca mg/L	Mg mg/L	M.Alk mg/L	Cl mg/L	SO4 mg/L	F mg/L	NO3-N mg/L
3319DD00066	ZN01	ZN01	19900601	0900	IGS (ZN1)	7.67	16.0	176	25	5.2	13	4	58	18	11	0.8	0.4
3319DD00066	ZN01	ZN1	19900907	1100	IGS	7.16	17.0	174	21	5.3	11	5	62	19	8	0.7	0.3
3319DD00066	ZN01	ZN1	19901205	1620	IGS	7.06	23.0	223	26	2.2	25	4	82	27	16	0.4	0.2
3319DD00066	ZN01	ZN1	19910227	0945	IGS	6.96	22.0	204	24	5.4	22	4	75	25	11	0.3	0.3
3319DD00067	ZN02	ZN02	19900601	0830	IGS (ZN2)	7.84	364.0^	2366	438^	20.0	228^	70	307	1032^	188	0.7	0.4
3319DD00067	ZN02	ZN2	19900907	1040	IGS	8.31	211.0+	1282	298+	15.6	73	47	116	594+	105	0.8	0.5
3319DD00067	ZN02	ZN2	19901205	1640	IGS	7.59	239.0+	1555	345+	7.7	88	53	150	731^	133	0.5	0.3
3319DD00067	ZN02	ZN2	19910227	0935	IGS	7.26	459.0^	3066	709^	29.0	184+	104^	325	1352^	275+	2.6^	0.2
3319DD00068	ZN03	ZN03	19881025	0900	HRI 11	6.70	19.0	96	11	4.7	8	3	29	17	3	0.7<	0.0
3319DD00068	ZN03	ZN03	19890426	1000	HRI 89617605	6.10	16.0	109	12	5.0	8	3	39	13	5	0.4	0.0
3319DD00068	ZN03	ZN03	19900601	0915	IGS (ZN3)	7.66	12.0	185	18	5.7	11	3	84	16	8	0.8	0.4
3319DD00068	ZN03	ZN3	19900907	1000	IGS	7.16	11.0	116	13	5.2	10	3	37	16	6	0.7	0.3
3319DD00068	ZN03	ZN3	19901205	1625	IGS	6.81	11.0	114	15	1.6	12	3	31	17	8	0.5	0.3
3319DD00068	ZN03	ZN3	19910227	0920	IGS	7.08	10.0	104	14	5.8	8	2	27	16	7	0.4	0.2
3319DD00105	R21		19881024	1530	HRI 8	7.80	486.0^	2737	595^	4.4	161+	148^	154	1343^	293+	0.6	0.0
3319DD00105	R21		19890426	1400	HRI 89617575	6.40	82.0+	429	84	2.1	29	21	56	173	47	0.3	0.0
3319DD00106	H4M19	H4M19	19881025	1000	HRI 14	7.70	371.0^	2099	441^	3.0	133	118^	149	944^	270+	0.7	0.2
3319DD00106	H4M19	H4M19	19890426	1220	HRI 89617630	6.60	113.0+	620	122+	2.7	41	32	79	252+	69	0.3	0.0
3319DD00106	H4M19	H4M19	19900530	1325	IGS (14)	8.21	352.0^	2328	464^	5.6	143	120^	220	1042^	271+	0.8	1.4
3319DD00106	H4M19	H4M19	19900622	0955	IGS (H4M19)	7.09	224.0+	1415	294+	5.2	92	75+	140	609^	157	2.9^	0.8
3319DD00106	H4M19	H4M19	19900723	0000	IGS	8.68	207.0+	1437	293+	3.8	91	74+	175	588+	173	0.9	0.9
3319DD00106	H4M19	H4M19	19900905	1645	IGS	8.02	274.0+	1819	367+	4.0	111	93+	204	761^	225+	0.9	1.0
3319DD00106	H4M19	H4M19	19900926	0938	IGS	7.66	294.0+	1949	388+	3.4	126	97+	223	823^	230+	0.8	1.1
3319DD00106	H4M19	VINK	19901026	0903	IGS	2.33v	454.0^	2056	336+	2.6	106	82+	0	716^	206+	4.6^	136.1^
3319DD00106	H4M19	H4M19	19901127	1540	IGS	7.58	316.0^	2138	457^	3.4	123	102^	209	904^	282+	1.4+	1.1
3319DD00106	H4M19	VINK	19901205	1030	IGS	8.02	335.0^	2255	471^	4.5	140	110^	241	952^	271+	0.7	1.1
3319DD00106	H4M19	VINK	19901219	0947	IGS	7.58	316.0^	2126	455^	4.2	122	106^	226	861^	290+	1.3+	1.0
3319DD00106	H4M19	VINK	19910123	0838	IGS	7.79	118.0+	2419	526^	3.8	147	121^	246	1002^	304+	1.6^	1.3
3319DD00106	H4M19	VINK	19910213	0800	IGS	7.98	303.0^	2417	524^	3.4	147	120^	250	999^	301+	2.8^	1.3
3319DD00106	H4M19	VINK	19910304	1130	IGS	8.10	284.0+	1840	386+	3.6	112	88+	192	761^	234+	2.8^	2.8
3319DD00106	H4M19	VINK	19910320	0000	IGS	7.96	369.0^	2329	519^	4.6	159+	118^	250	928^	290+	0.6	1.2
3319DD00106	H4M19	VINKRIVI	19910424	0000	IGS	8.43	386.0^	2526	547^	5.0	156+	121^	258	1083^	306+	0.4	1.2
3319DD00107	R35		19881024	1245	HRI 5	5.40v	8.0	37	7	0.0	2	2	7	14	1	0.7<	0.0
3319DD00107	R35		19890426	1230	HRI 89617540	6.30	89.0+	542	89	1.4	44	22	133	154	62	0.3	0.1
3319DD00108	H4M16		19881025	1330	HRI 16	8.10	457.0^	2953	717^	12.7	119	116^	405	944^	540+	1.2+	0.0
3319DD00108	H4M16		19890426	0915	HRI 8961754	6.50	112.0+	632	162+	3.5	17	23	67	231	109	0.3	0.0
3319DD00109	B5		19881025	1200	HRI 15	7.80	346.0^	2193	510^	2.4	86	103^	413	804^	175	0.8	0.0
3319DD00109	B5		19890426	0830	HRI 89617642	6.70	129.0+	780	181+	4.4	24	33	144	295+	58	0.4	0.0
3319DD00109	B5	B5	19900606	0830	IGS (15)	8.79	202.0+	1276	416^	3.3	19	34	205	554+	4	0.9	0.4
3319DD00109	B5	B	19901204	0830	IGS	7.59	271.0+	1497	471^	2.0	77	21	422	249	147	2.4^	0.3
3319DD00109	B5	B5	19910228	1415	IGS	7.08	300.0+	2132	488^	2.5	77	91+	456	743^	163	1.1+	0.3
3319DD00111	Z	Z	19900605	1600	IGS (Z)	6.95	69.0	515	89	1.2	39	22	142	128	51	0.3	1.0
3319DD00111	Z	Z	19900903	0830	IGS	7.47	63.0	451	73	1.3	38	20	122	113	46	0.3	0.9
3319DD00111	Z	Z	19901203	0830	IGS	6.93	72.0+	525	86	0.5	45	23	134	136	60	0.3	0.9
3319DD00111	Z	Z	19910226	0850	IGS	8.12	95.0+	666	106+	1.4	52	29	158	200	73	0.5	0.8
3319DD00112	AA	AA	19900605	0000	IGS (AA)	7.11	63.0	483	78	0.4	40	19	137	114	53	0.4	1.0
3319DD00112	AA	AA	19900903	0840	IGS	7.28	57.0	424	65	1.5	38	18	116	105	45	0.3	0.7
3319DD00112	AA	AA	19901203	0845	IGS	7.06	67.0	515	80	0.3	49	21	142	127	54	0.4	0.7

163

Site id	# on map	Sample #	Date	Time	Lab.	pH	EC mS/m	TDS () mg/L	Na mg/L	K mg/L	Ca mg/L	Mg mg/L	M.Alk mg/L	Cl mg/L	SO4 mg/L	F mg/L	NO3-N mg/L
3319DD00113	NELS	NELS	19900530	1400	IGS (B)	7.27	16.0	151	27	1.6	13	5	42	32	15	0.7	0.3
3319DD00113	NELS	NELS	19900622	0938	IGS (B)	7.12	12.0	121	27	1.0	10	4	32	23	12	0.6	0.3
3319DD00113	NELS	NELS	19900723	0000	IGS	7.42	29.0	232	41	1.5	19	8	66	51	23	0.5	0.4
3319DD00113	NELS	NELS	19900900	0000	IGS	7.55	61.0	451	75	2.1	37	15	132	110	42	0.4	0.4
3319DD00113	NELS	NELS	19900905	1700	IGS	8.03	46.0	352	57	2.6	30	12	110	79	30	0.4	0.3
3319DD00113	NELS	NELS	19901000	0000	IGS	7.17	58.0	448	75	3.1	38	15	130	113	36	0.3	0.5
3319DD00113	NELS	NELS	19901205	1100	IGS	7.02	55.0	408	65	0.4	35	13	128	103	29	0.1	0.3
3319DD00113	NELS	NELS	19910304	1140	IGS	6.77	47.0	360	54	1.8	31	12	109	80	33	0.3	1.6
3319DD00114	AE	AE	19900607	1530	IGS (AE)	8.28	58.0	529	97	7.0	31	14	227	54	28	1.8^	1.0
3319DD00115	AC	AC	19900607	1400	IGS (AC)	7.63	91.0+	645	112+	0.7	49	25	168	179	61	0.3	0.7
3319DD00116	AD	AD	19900607	1405	IGS (AD)	7.34	81.0+	560	99	0.6	38	23	139	165	54	0.2	0.5
3319DD00117	AG	AG	19900608	1100	IGS (AG)	7.18	12.0	90	18	0.7	6	4	12	29	12	0.4	0.7
3319DD00118	LE01	LE01	19900609	1100	IGS (LAC)	6.90	23.0	189	20	7.3	18	8	41	38	28	0.5	0.3
3319DD00118	LE01	LE1	19900906	1600	IGS	7.49	24.0	189	19	7.7	19	8	42	39	26	0.5	0.3
3319DD00118	LE01	LE1	19901207	1300	IGS	7.40	24.0	198	22	7.3	21	7	42	42	27	0.2	0.3
3319DD00118	LE01	LE01	19910304	1140	IGS	7.57	24.0	206	23	6.6	19	8	51	40	27	0.3	0.3
3319DD00119	H4H11	KEISERS	19900530	1625	IGS (C)	8.22	346.0^	2349	583^	11.2	68	85+	299	928^	300+	0.9	0.4
3319DD00119	H4H11	KEISERS	19900621	1242	IGS (H4H11)	8.08	315.0^	2152	539^	10.1	69	80+	285	829^	267+	1.1+	0.5
3319DD00119	H4H11	KEISERS	19900723	0000	IGS	8.43	284.0+	2107	544^	9.5	69	80+	280	770^	292+	0.7	0.4
3319DD00119	H4H11	KEISER	19900900	0000	IGS	7.96	377.0^	2606	646^	10.9	83	93+	376	978^	329+	1.5+	0.5
3319DD00119	H4H11	KEISERS	19901025	1229	IGS	8.29	486.0^	3307	927^	13.6	103	126^	446	1140^	448+	2.2^	0.3
3319DD00119	H4H11	KEISERS	19901127	1233	IGS	8.18	521.0^	3969	1045^	17.2	105	144^	449	1571^	532+	3.1^	0.4
3319DD00119	H4H11	KEISER	19901205	1725	IGS	8.41	565.0^	4023	986^	15.9	113	149^	422	1693^	546+	1.0	0.3
3319DD00119	H4H11	KEISERS	19901218	0000	IGS	7.84	446.0^	3633	932^	14.5	114	139^	410	1448^	478+	2.2^	0.3
3319DD00119	H4H11	KEISERS	19910122	0000	IGS	8.07	140.0+	5075	1432^	22.6	141	199^	474	2038^	654^	2.3^	0.7
3319DD00119	H4H11	KEISERS	19910212	0000	IGS	8.13	451.0^	4496	1245^	19.1	129	180^	452	1781^	578+	4.9^	0.6
3319DD00119	H4H11	KEISERS	19910305	0825	IGS	8.36	627.0^	4293	1123^	15.8	126	167^	440	1726^	583+	2.9^	1.4
3319DD00119	H4H11	KEISERS	19910319	0000	IGS	8.48	456.0^	3063	791^	14.3	96	119^	339	1265^	385+	0.6	0.0
3319DD00119	H4H11	KEISERS	19910423	0000	IGS	8.45	670.0^	4537	1173^	17.0	138	175^	482	1904^	567+	1.2+	0.4
3319DD00120	P	P	19900602	1045	IGS (P)	7.86	24.0	223	35	5.4	21	7	84	31	14	0.6	0.5
3319DD00120	P	P	19900905	0845	IGS	8.03	21.0	203	26	6.1	20	4	100	14	4	0.5	0.3
3319DD00120	P	P	19901205	1710	IGS	7.85	20.0	195	27	1.3	21	4	94	17	4	0.2	0.3
3319DD00120	P	P	19910227	0900	IGS	7.46	21.0	252	24	5.2	18	5	134	26	4	0.3	0.3
3319DD00121	Q	Q	19900602	1015	IGS (Q)	9.56^	728.0^	5106	1613^	48.1	11	105^	1195	1750^	387+	1.5+	2.6
3319DD00122	R	R	19900602	1000	IGS (R)	7.30	36.0	283	47	7.8	27	10	57	83	20	0.6	0.6
3319DD00123	S	S	19900602	0945	IGS (S)	6.83	28.0	219	28	8.4	23	7	46	64	12	0.6	0.3
3319DD00124	CD1A	CD1A	19900601	0000	IGS (CD1A)	7.25	11.0	110	13	5.7	10	3	33	16	5	0.7	0.3
3319DD00124	CD1A	CD1A	19900905	0950	IGS	6.58	11.0	116	12	6.0	9	3	36	16	7	0.7	0.3
3319DD00124	CD1A	CD1A	19901205	1605	IGS	6.41	12.0	141	12	5.8	14	3	61	15	5	0.5	0.2
3319DD00124	CD1A	CD1A	19910227	1000	IGS	6.36	15.0	120	12	5.8	9	3	34	25	6	0.3	0.3
3319DD00125	N	N	19900601	0000	IGS (N)	7.92	22.0	220	19	7.4	29	3	92	19	9	0.5	0.4
3319DD00125	N	N	19900905	0930	IGS	7.77	33.0	275	22	8.9	41	5	86	53	18	0.4	0.3
3319DD00125	N	N	19901205	1220	IGS	7.11	76.0+	523	54	13.9	77	14	93	178	51	0.2	0.3
3319DD00125	N	N	19910227	1100	IGS	7.00	73.0+	491	51	12.3	71	14	90	164	48	0.2	0.3
3319DD00126	HOOPS	HOOPS	19900609	1015	IGS (HOOPS)	8.20	136.0+	985	208+	4.5	51	37	265	266+	83	0.5	0.6
3319DD00126	HOOPS	HOOPS	19900621	0109	IGS (HOOPS)	7.27	72.0+	495	100	6.5	40	16	88	154	59	0.3	1.9
3319DD00126	HOOPS	HOOPS	19900723	0000	IGS	8.21	160.0+	1271	273+	3.9	77	47	326	342+	115	0.7	1.0
3319DD00126	HOOPS	HOOPS	19900900	0000	IGS	7.07	218.0+	1741	339+	5.1	88	54	507	487+	133	1.7^	0.6

Site id	# on map	Sample #	Date	Time	Lab.	pH	EC mS/m	TDS () mg/L	Na mg/L	K mg/L	Ca mg/L	Mg mg/L	H.Alk mg/L	Cl mg/L	SO4 mg/L	F mg/L	NO3-N mg/L
3319DD00126	HOOPS	HOOPS	19900905	1625	IGS	7.88	134.0+	933	190+	3.3	54	33	213	303+	81	0.5	0.3
3319DD00126	HOOPS	HOOPS	19901025	0000	IGS	7.92	187.0+	1377	296+	3.5	75	44	302	463+	115	1.0	0.4
3319DD00126	HOOPS	HOOPS	19901127	0000	IGS	7.63	221.0+	1625	349+	19.9	84	51	393	499+	129	2.4^	0.2
3319DD00126	HOOPS	HOOPS	19901205	1105	IGS	7.85	251.0+	1823	403^	5.1	105	63	394	608^	142	0.8	0.3
3319DD00126	HOOPS	HOOPS	19901218	0000	IGS	7.66	110.0+	1766	389+	6.8	91	59	381	605^	134	2.7^	0.3
3319DD00126	HOOPS	HOOPS	19910122	0000	IGS	7.93	283.0+	1991	443^	6.1	112	69	390	701^	167	2.2^	0.4
3319DD00126	HOOPS	HOOPS	19910213	0000	IGS	7.98	279.0+	2357	553^	8.3	135	83+	435	844^	186	1.0	0.3
3319DD00126	HOOPS	HOOPS	19910305	0810	IGS	7.80	303.0^	2120	472^	9.6	122	73+	388	785^	161	3.5^	1.6
3319DD00126	HOOPS	HOOPS	19910319	0000	IGS	7.80	167.0+	1086	252+	7.2	69	40	227	346+	93	0.6	0.3
3319DD00126	HOOPS	HOOPSRIV	19910423	0000	IGS	8.34	252.0+	1718	394+	7.7	102	59	322	622^	149	0.6	0.1
3319DD00127	AF	AF	19900608	1000	IGS (AF)	7.24	15.0	156	15	5.8	13	4	65	13	5	0.7	0.3
3319DD00127	AF	AF	19900904	1630	IGS	7.37	15.0	158	17	5.5	13	4	63	14	5	0.6	0.3
3319DD00127	AF	AF	19901204	1530	IGS	7.05	16.0	162	18	6.3	15	4	64	15	5	0.4	0.3
3319DD00127	AF	AF	19910228	1445	IGS	6.80	15.0	179	17	5.7	14	4	78	14	4	0.4	1.4
3319DD00128	ROB01	ROB01	19900621	1126	IGS (ROB01)	7.16	40.0	276	62	2.8	15	12	32	96	40	0.2	1.5
3319DD00128	ROB01	ROB01	19900723	0000	IGS	7.04	29.0	243	69	3.5	15	15	25	66	35	0.3	1.2
3319DD00128	ROB01	ROB01	19900900	0000	IGS	6.94	35.0	239	54	0.7	12	11	30	83	35	0.3	1.0
3319DD00128	ROB01	ROB01	19901130	0946	IGS	6.74	31.0	211	48	1.1	11	9	27	74	32	0.1	0.5
3319DD00128	ROB01	ROB01	19901218	1100	IGS	6.62	23.0	184	41	1.1	10	8	24	67	25	0.1	0.5
3319DD00128	ROB01	ROB01	19910122	0000	IGS	6.48	17.0	145	31	0.9	8	5	26	46	19	0.0	0.5
3319DD00128	ROB01	ROB01	19910319	0000	IGS	6.78	21.0	161	37	1.3	9	7	37	47	14	0.6	0.1
3319DD00128	ROB01	ROB01	19910423	0000	IGS	6.59	28.0	192	49	1.9	10	9	30	65	19	0.2	0.2
3319DD00129	VOOGDS_KLEIN	VOOGDS_K	19900621	0000	IGS (VOOGDS_K)	8.09	297.0+	1931	500^	10.9	60	73+	225	810^	192	0.9	0.6
3319DD00129	VOOGDS_KLEIN	VOOGDS_K	19900723	0000	IGS	8.62	314.0^	2300	625^	11.4	68	88+	256	963^	238+	0.6	0.6
3319DD00129	VOOGDS_KLEIN	KLAASVGS	19900900	0000	IGS	7.71	302.0^	2038	510^	10.0	66	74+	244	864^	206+	0.8	1.0
3319DD00129	VOOGDS_KLEIN	KLAASKLE	19901025	1100	IGS	8.00	307.0^	2151	558^	9.0	72	77+	286	856^	220+	1.3+	1.0
3319DD00129	VOOGDS_KLEIN	KLAASKLE	19901130	0000	IGS	7.64	248.0+	1744	432^	5.1	56	69	234	642^	243+	0.9	1.0
3319DD00129	VOOGDS_KLEIN	KLAASKLE	19901218	0000	IGS	7.92	273.0+	2838	770^	14.0	88	111^	303	1146^	321+	2.2^	1.8
3319DD00129	VOOGDS_KLEIN	KLAASKLE	19910122	0000	IGS	7.81	128.0+	3339	871^	18.8	116	141^	386	1348^	337+	4.4^	4.8
3319DD00129	VOOGDS_KLEIN	VOOGDSKL	19910212	0000	IGS	7.81	231.0+	1797	456^	7.9	65	73+	240	660^	228+	1.0	1.1
3319DD00129	VOOGDS_KLEIN	VOOGSKLE	19910319	0000	IGS	8.39	220.0+	1479	385+	18.8	51	54	245	529+	151	0.4	0.4
3319DD00129	VOOGDS_KLEIN	VOOGDSKL	19910423	0000	IGS	8.55	262.0+	1727	449^	8.5	59	63	260	663^	182	0.7	0.3
3319DD00130	VOOGDS_GROOT	VOOGDS_G	19900625	1540	IGS (VOOGDS_G)	7.93	239.0+	1634	410^	6.4	54	63	222	609^	207+	1.1+	1.2
3319DD00130	VOOGDS_GROOT	VOOGDS_G	19900723	0000	IGS	7.07	230.0+	1668	410^	5.7	54	66	227	625^	221+	0.9	0.3
3319DD00130	VOOGDS_GROOT	KLAASVGD	19900900	0000	IGS	7.89	161.0+	1062	248+	4.7	37	41	155	400+	135	0.7	0.4
3319DD00130	VOOGDS_GROOT	KLAASGRT	19901025	1100	IGS	7.58	205.0+	1449	358+	4.8	47	54	208	540+	182	0.8	0.5
3319DD00130	VOOGDS_GROOT	KLAASGRO	19901130	0000	IGS	7.80	276.0+	1919	465^	10.0	65	72+	270	757^	205+	1.5+	1.7
3319DD00130	VOOGDS_GROOT	KLAASGRO	19901218	0000	IGS	7.54	116.0+	1885	465^	7.6	60	73+	244	708^	261+	0.9	1.2
3319DD00130	VOOGDS_GROOT	KLAASGRO	19910122	0000	IGS	7.50	263.0+	1796	434^	5.4	63	73+	237	656^	263+	1.1+	1.1
3319DD00130	VOOGDS_GROOT	VOOGDSGR	19910212	0000	IGS	7.94	381.0^	2291	918^	16.8	87	130^	379	325+	330+	4.4^	1.7
3319DD00130	VOOGDS_GROOT	VOOGDSGR	19910319	0000	IGS	8.43	262.0+	1721	460^	8.0	58	64	258	670^	161	0.4	0.3
3319DD00130	VOOGDS_GROOT	VOOGDSGR	19910423	0000	IGS	8.37	222.0+	1484	379+	8.0	57	59	197	548+	194	0.5	0.4
3319DD00131	ANG01	ANG01	19900621	1219	IGS (ANG01)	7.06	44.0	303	72	3.9	16	14	35	105	41	0.2	1.2
3319DD00131	ANG01	ANG01	19900723	0000	IGS	7.42	33.0	260	53	3.2	14	11	44	79	36	0.3	1.1
3319DD00131	ANG01	ANGORA01	19900900	0000	IGS	7.00	41.0	272	61	1.2	13	12	35	98	39	0.3	0.8
3319DD00131	ANG01	ANG01	19901025	1153	IGS	7.06	52.0	350	79	1.2	17	15	44	133	47	0.2	0.6
3319DD00131	ANG01	ANG01	19901218	0902	IGS	6.85	44.0	285	67	1.3	14	12	35	107	38	0.1	0.4
3319DD00131	ANG01	ANG01	19910122	0932	IGS	6.69	32.0	247	72	1.6	15	13	27	74	36	0.1	0.2

Site id	# on map	Sample #	Date	Time	Lab.	pH	EC mS/m	TDS () mg/L	Na mg/L	K mg/L	Ca mg/L	Mg mg/L	H.Alk mg/L	Cl mg/L	SO4 mg/L	P mg/L	NO3-N mg/L
3319DD00131	ANG01	ANG01	19910212	0000	IGS	6.61	40.0	302	69	1.2	14	12	60	95	37	0.1	0.1
3319DD00131	ANG01	ANG01	19911127	1211	IGS	6.80	49.0	348	71	1.8	16	14	43	145	45	0.1	0.5
3319DD00132	SAN01	SAN01	19900621	0927	IGS (SAN01)	7.07	45.0	311	72	3.0	16	13	37	110	43	0.4	1.1
3319DD00132	SAN01	SAN01	19900723	0000	IGS	6.90	31.0	230	58	3.1	11	11	28	71	34	0.3	1.2
3319DD00132	SAN01	SAN01	19900900	0000	IGS	6.83	42.0	292	63	1.7	22	13	39	101	39	0.2	0.7
3319DD00132	SAN01	SAN01	19901025	0935	IGS	7.04	59.0	396	87	2.2	18	17	53	155	48	0.2	0.6
3319DD00132	SAN01	SAN01	19901130	0940	IGS	6.96	61.0	401	89	2.7	19	18	54	147	55	0.3	0.6
3319DD00132	SAN01	SAN01	19901218	1003	IGS	6.79	43.0	358	96	3.4	19	17	54	121	33	0.2	0.3
3319DD00132	SAN01	SAN01	19910122	0000	IGS	6.89	45.0	279	64	1.6	13	12	39	100	38	0.2	0.4
3319DD00132	SAN01	SAN01	19910212	0000	IGS	7.04	51.0	331	79	2.2	17	14	43	122	42	0.2	0.5
3319DD00132	SAN01	SAN01	19910320	0000	IGS	7.25	46.0	337	78	2.1	18	13	82	97	28	0.0	0.3
3319DD00133	SAND	SAND	19900622	0944	IGS (SANDRIV)	7.94	86.0+	653	145+	6.9	36	20	174	179	38	0.9	0.7
3319DD00133	SAND	SAND	19900723	0000	IGS	7.30	22.0	173	38	1.1	11	5	43	45	13	0.6	0.5
3319DD00133	SAND	SANDRIV	19900900	0000	IGS	7.78	120.0+	1046	189+	6.8	44	25	396	224	53	1.5+	0.8
3319DD00133	SAND	SANDRIVI	19901000	0000	IGS	7.89	127.0+	1022	231+	8.9	43	26	317	249	58	1.2+	0.5
3319DD00133	SAND	SANDRIV	19901127	0000	IGS	7.91	150.0+	1196	273+	11.7	46	28	402	253+	71	3.3+	0.4
3319DD00133	SAND	SANDRIVI	19901218	0000	IGS	7.88	145.0+	1238	298+	11.1	48	33	411	245	79	3.0+	0.5
3319DD00133	SAND	SANDRIVI	19910122	0000	IGS	7.90	153.0+	1228	281+	11.4	44	28	428	239	78	3.4+	0.3
3319DD00133	SAND	SANDRIVI	19910213	0000	IGS	7.85	157.0+	1334	343+	15.3	47	33	407	281+	94	0.5	0.4
3319DD00133	SAND	SANDRIVI	19910320	0000	IGS	8.66	190.0+	1432	346+	19.4	53	33	537	333+	40	2.2+	0.3
3319DD00133	SAND	SANDRIVI	19910424	0000	IGS	8.57	184.0+	1374	328+	13.9	56	34	448	327+	90	2.1+	0.3
3319DD00134	TY SIG	SIG	19900904	1630	IGS	7.96	215.0+	1552	422+	7.6	32	51	278	510+	172	0.6	1.0
3319DD01593	G33593	G33593	19900620	0000	IGS (G33593)	9.06+	600.0+	3960	1237+	46.6	10	114+	378	1866+	265+	1.7+	0.3
3319DD01593	G33593	G33593	19900727	0000	IGS	9.00	618.0+	4349	1371+	50.6	9	125+	357	2047+	346+	1.3+	0.2
3319DD01593	G33593	G33593	19900900	0000	IGS	8.62	665.0+	4367	1319+	49.1	16	118+	351	2096+	355+	1.3+	0.1
3319DD01593	G33593	G33593	19901000	0000	IGS	8.37	677.0+	4561	1480+	50.9	20	119+	354	2089+	373+	2.2+	0.3
3319DD01593	G33593	G33593	19901220	0000	IGS	7.50	244.0+	2459	1324+	28.4	12	97+	136	693+	135	1.0	0.3
3319DD01593	G33593	G33593	19910131	0000	IGS	8.63	647.0+	4261	1371+	44.4	15	114+	351	1960+	344+	2.6+	0.4
3319DD01593	G33593	G33593	19910305	0000	IGS	7.40	56.0	367	94	9.0	21	14	54	122	39	0.2	0.5
3319DD01593	G33593	G33593	19910426	0000	IGS	7.61	56.0	423	90	9.1	19	14	105	122	38	0.2	0.6
3319DD01594	G33594	G33594	19900620	0000	IGS (G33594)	8.81	588.0+	3843	1224+	29.3	14	113+	255	2022+	142	1.4+	1.0
3319DD01594	G33594	G33594	19900727	0000	IGS	8.71	588.0+	4119	1350+	29.7	18	124+	258	2108+	186	1.6+	0.3
3319DD01594	G33594	G33594	19900900	0000	IGS	8.92	622.0+	3790	1216+	26.9	11	102+	260	1977+	160	2.6+	0.7
3319DD01594	G33594	G33594	19901000	0000	IGS	9.00	617.0+	4188	1230+	25.8	10	94+	261	2407+	129	2.2+	0.6
3319DD01594	G33594	G33594	19910305	0000	IGS	8.36	1418.0+	9397	2588+	44.9	184+	305+	393	4652+	1156+	1.6+	0.3
3319DD01594	G33594	G33594	19910426	0000	IGS	8.57	1376.0+	8928	2479+	46.9	173+	288+	398	4396+	1079+	1.7+	0.2
3319DD01595	G33595	G33595	19900608	1330	IGS (AJ)	7.36	1206.0+	8244	2518+	46.5	97	319+	90	4447+	686+	4.0+	0.2
3319DD01595	G33595	G33595	19900906	1400	IGS	7.17	1296.0+	8467	2467+	45.3	115	325+	102	4664+	711+	7.4+	0.2
3319DD01596	G33596	G33596	19900619	0000	IGS (G33596)	8.74	870.0+	5906	1815+	19.6	17	180+	670	2564+	529+	2.3+	0.0
3319DD01596	G33596	G33596	19900724	0000	IGS	8.67	679.0+	6111	2032+	21.2	17	181+	696	2446+	595+	1.9+	0.3
3319DD01596	G33596	G33596	19900900	0000	IGS	8.51	870.0+	6042	1826+	18.4	22	175+	671	2619+	579+	2.9+	0.1
3319DD01596	G33596	G33596	19901000	0000	IGS	8.67	871.0+	6474	1991+	17.4	14	179+	627	2973+	565+	4.1+	0.2
3319DD01596	G33596	G33596	19901200	0000	IGS	7.96	233.0+	1468	316+	3.4	94	71+	221	551+	151	0.6	0.2
3319DD01596	G33596	G33596	19910131	0000	IGS	7.31	234.0+	1566	317+	4.0	91	71+	231	641+	151	0.7	0.2
3319DD01596	G33596	G33596	19910228	0000	IGS	7.78	1416.0+	8554	2444+	26.8	46	437+	76	5116+	386+	0.3	1.1
3319DD01596	G33596	G55396	19910425	0000	IGS	8.06	1416.0+	8596	2447+	24.2	43	430+	80	5181+	372+	0.3	0.2
3319DD01598	G33598	G33598	19900620	0000	IGS (G33598)	7.39	226.0+	1438	376+	15.7	35	69	134	642+	127	0.4	0.4
3319DD01598	G33598	G33598	19900727	0000	IGS	6.66	230.0+	1469	385+	16.8	33	68	111	664+	153	3.9+	0.5

Site id	# on map	Sample #	Date	Time	Lab.	pH	EC mS/m	TDS () mg/L	Na mg/L	K mg/L	Ca mg/L	Mg mg/L	M.Alk mg/L	Cl mg/L	SO4 mg/L	F mg/L	NO3-N mg/L
3319DD01598	G33598	G33598	19900900	0000	IGS	7.32	236.0+	1470	367+	15.4	34	63	134	665^	153	0.1	0.4
3319DD01598	G33598	G33598	19901000	0000	IGS	7.12	239.0+	1597	386+	15.9	49	63	139	754^	149	0.9	0.3
3319DD01598	G33598	G33598	19901200	0000	IGS	7.21	71.0+	462	131+	4.1	11	9	64	192	33	0.3	0.6
3319DD01598	G33598	G33598	19910131	0000	IGS	7.14	234.0+	1448	363+	16.0	35	63	137	636^	157	2.1^	0.3
3319DD01598	G33598	G33598	19910305	0000	IGS	8.06	715.0^	4169	1363^	47.9	20	82+	122	2407^	99	0.6	0.1
3319DD01598	G33598	G33598	19910426	0000	IGS	8.54	712.0^	4081	1366^	43.0	17	75+	77	2408^	85	0.6	0.1
3319DD01599	G33599	G33599	19900620	0000	IGS (G33599)	7.86	987.0^	6772	1895^	32.1	118	187^	391	3515^	532+	3.3^	0.6
3319DD01599	G33599	G33599	19900700	0000	IGS	8.31	1413.0^	11985^	3401^	56.4	261^	439^	363	5870^	1499^	4.9^	0.2
3319DD01600	G33600	G33600	19900619	0000	IGS (G33600)	9.05+	382.0^	2236	728^	13.9	14	71+	105	1245^	48	0.8	0.3
3319DD01600	G33600	G33600	19900724	0000	IGS	6.51	336.0^	2268	777^	15.2	13	73+	77	1224^	61	7.0^	0.3
3319DD01600	G33600	G33600	19900900	0000	IGS	8.06	367.0^	2272	685^	14.2	25	68	148	1193^	101	1.7^	0.3
3319DD01600	G33600	G33600	19901000	0000	IGS	7.35	361.0^	2482	691^	14.1	74	72+	218	1147^	207+	1.5+	0.3
3319DD01600	G33600	G33600	19901200	0000	IGS	7.38	356.0^	2259	652^	14.6	75	71+	203	975^	210+	1.9^	0.4
3319DD01600	G33600	G33600	19910131	0000	IGS	7.52	347.0^	2238	635^	12.8	68	68	206	981^	207+	3.1^	0.6
3319DD01600	G33600	G33600	19910425	0000	IGS	8.56	236.0+	1509	427^	9.4	44	51	175	636^	134	0.9	0.1
3319DD01601	G33601	G33601	19900619	0000	IGS (G33601)	8.42	630.0^	3892	1038^	14.0	51	228^	159	2137^	237+	0.3	0.3
3319DD01601	G33601	G33601	19900724	0000	IGS	7.98	529.0^	3893	1106^	14.6	43	228^	88	2164^	227+	1.6^	0.2
3319DD01601	G33601	G33601	19900900	0000	IGS	8.38	631.0^	3717	995^	11.8	35	204^	69	2193^	196	0.7	0.0
3319DD01601	G33601	G33601	19901000	0000	IGS	8.62	612.0^	4018	1081^	13.1	46	201^	59	2436^	166	2.0^	0.1
3319DD01601	G33601	G33601	19901220	0000	IGS	8.18	231.0+	1592	497^	9.9	23	34	284	504+	161	2.9^	1.1
3319DD01601	G33601	G33601	19910131	0000	IGS	7.73	225.0+	1557	474^	8.5	22	23	275	523+	154	2.9^	1.0
3319DD01601	G33601	G33601	19910228	0000	IGS	6.53	611.0^	3600	998^	15.9	62	177^	46	2043^	247+	0.6	0.2
3319DD01601	G33601	G33601	19910425	0000	IGS	6.51	645.0^	3848	1033^	17.7	118	180^	52	2148^	287+	0.7	0.1
3319DD01602	G33602	G33602	19900619	0000	IGS (G33602)	9.07+	518.0^	3387	937^	16.6	18	147^	299	1640^	267+	1.1+	0.3
3319DD01602	G33602	G33602	19900724	0000	IGS	7.97	469.0^	3439	1012^	15.1	43	169^	139	1742^	284+	1.4+	0.2
3319DD01602	G33602	G33602	19900900	0000	IGS	7.23	580.0^	3735	887^	14.2	149	179^	256	1817^	365+	1.2+	0.0
3319DD01602	G33602	G33602	19901000	0000	IGS	7.89	595.0^	4371	979^	14.6	155+	186^	270	2330^	365+	3.0^	0.3
3319DD01602	G33602	G33602	19901200	0000	IGS	7.48	630.0^	3615	1094^	14.0	33	202^	80	2019^	151	2.0^	0.2
3319DD01602	G33602	G33602	19910131	0000	IGS	6.85	612.0^	3676	1074^	13.2	30	196^	49	2161^	137	1.1+	0.4
3319DD01602	G33602	G33602	19910218	0000	IGS	6.81	133.0+	1186	556^	13.9	70	68	31	437+	2	0.4	0.1
3319DD01602	G33602	G33602	19910425	0000	IGS	7.07	135.0+	808	223+	2.7	27	33	68	436+	3	0.3	0.1
3319DD01603	G33603	G33603	19900000	0000	IGS	7.19	568.0^	3824	1002^	21.3	158+	141^	282	1817^	326+	2.6^	0.5
3319DD01603	G33603	G33603	19900619	0000	IGS (G33603)	7.08	587.0^	3909	1017^	20.8	166+	157^	283	1860^	331+	1.5+	0.3
3319DD01603	G33603	G33603	19900724	0000	IGS	7.19	499.0^	3902	1058^	22.1	163+	160^	283	1800^	339+	1.5+	0.7
3319DD01603	G33603	G33603	19900900	0000	IGS	7.56	588.0^	3788	945^	19.7	157+	143^	283	1840^	326+	1.0	0.3
3319DD01603	G33603	G33603	19901200	0000	IGS	8.02	590.0^	3589	978^	22.8	156+	135^	236	1700^	296+	2.1^	0.1
3319DD01603	G33603	G33603	19910131	0000	IGS	7.22	553.0^	3855	986^	21.6	148	134^	305	1870^	310+	2.3^	0.4
3319DD01603	G33603	G33603	19910228	0000	IGS	7.72	576.0^	3681	934^	22.3	160+	135^	292	1772^	300+	0.6	0.2
3319DD01603	G33603	G33603	19910425	0000	IGS	7.91	571.0^	3627	920^	22.5	149	133^	282	1755^	301+	0.7	0.3
3319DD01605	G33605	G33605	19900619	0000	IGS (G33605)	6.64	334.0^	1899	385+	2.8	95	152^	54	1109^	83	2.0^	0.3
3319DD01605	G33605	G33605	19900724	0000	IGS	6.80	344.0^	2434	438^	4.6	186+	174^	164	1139^	267+	9.1^	0.3
3319DD01605	G33605	G33605	19901200	0000	IGS	7.74	258.0+	1675	340+	4.5	109	87+	226	674^	169	0.7	1.1
3319DD01605	G33605	G33605	19910131	0000	IGS	7.12	263.0+	1719	349+	4.9	106	88+	228	700^	180	0.5	0.6
3319DD01605	G33605	G33605	19910228	0000	IGS	8.03	1535.0^	10397^	2939^	58.7	161+	312^	532	5049^	1223^	1.4+	0.8
3319DD01605	G33605	G33605	19910415	0000	IGS	7.83	1541.0^	10600^	2983^	60.8	159+	310^	707	5025^	1194^	1.5+	0.9
3319DD01606	G33606	G33606	19900619	0000	IGS (G33606)	8.85	136.0+	748	185+	1.9	19	54	33	449+	4	0.4	0.3
3319DD01606	G33606	G33606	19900724	0000	IGS	8.10	141.0+	882	198+	2.1	37	64	69	466+	27	0.3	0.3
3319DD01606	G33606	G33606	19901200	0000	IGS	6.62	180.0+	1035	173+	1.9	88	70	48	549+	73	0.3	0.4

167

Site id	# on map	Sample #	Date	Time	Lab.	pH	EC mS/m	TDS () mg/L	Na mg/L	K mg/L	Ca mg/L	Mg mg/L	M.Alk mg/L	Cl mg/L	SO4 mg/L	P mg/L	NO3-N mg/L
3319DD01606	G33606	G33606	19910131	0000	IGS	6.69	175.0+	1035	172+	2.2	86	68	47	544+	85	1.2+	0.4
3319DD01606	G33606	G33606	19910228	0000	IGS	7.56	335.0^	1922	471^	4.9	51	152^	46	1122^	64	0.4	0.1
3319DD01606	G33606	G33606	19910425	0000	IGS	7.22	330.0^	1905	466^	5.3	47	144^	73	1109^	44	0.4	0.1
3319DD01607	G33607	G33607	19900619	0000	IGS (G33607)	5.86-	131.0+	754	205+	2.2	25	35	44	421+	6	4.2^	0.3
3319DD01607	G33607	G33607	19900724	0000	IGS	7.89	126.0+	776	219+	2.4	23	36	50	427+	6	0.4	0.1
3319DD01607	G33607	G33607	19901200	0000	IGS	7.26	637.0^	4080	993^	19.0	162+	197^	267	1994^	374+	2.0^	0.9
3319DD01607	G33607	G33607	19910131	0000	IGS	7.33	578.0^	3772	1040^	15.2	79	184^	142	1950^	321+	1.5+	0.6
3319DD01607	G33607	G33607	19910228	0000	IGS	6.99	140.0+	768	175+	2.2	25	56	47	448+	4	0.2	0.1
3319DD01607	G33607	G33607	19910425	0000	IGS	6.76	133.0+	741	197+	2.6	27	51	19	438+	2	0.2	0.1
3319DD02572	G33572A	G33572A	19900620	0000	IGS (G33572A)	7.74	528.0^	3364	966^	35.4	84	108^	236	1661^	211+	1.3+	0.4
3319DD02572	G33572A	G33572A	19900727	0000	IGS	8.60	522.0^	3572	1034^	36.8	86	114^	243	1730^	270+	0.5	0.2
3319DD02572	G33572A	G55372A	19901200	0000	IGS	7.85	556.0^	3425	1035^	37.1	88	105^	239	1601^	257+	1.6^	0.4
3319DD02572	G33572A	G33572A	19910131	0000	IGS	7.79	538.0^	3234	1032^	36.3	94	108^	240	1655^	5	0.0	2.5
3319DD02572	G33572A	G33572A	19910305	0000	IGS	8.42	2070.0^	13905^	3650^	90.6	321^	574^	494	7784^	905^	1.5+	0.8
3319DD02572	G33572A	G33572A	19910426	0000	IGS	8.23	2070.0^	13744^	3425^	97.8	323^	572^	493	7814^	906^	1.4+	0.8
3319DD02574	G33574A	G33574A	19900727	0000	IGS	8.10	857.0^	5991	1285^	51.6	203^	326^	338	3289^	406+	2.1^	0.9
3319DD02574	G33574A	G33574A	19900900	0000	IGS	7.98	946.0^	5999	1365^	51.7	233^	345^	329	3126^	453+	4.8^	1.3
3319DD02574	G33574A	G33574A	19901000	0000	IGS	7.53	926.0^	6397	1465^	57.1	221^	341^	307	3505^	414+	3.1^	0.4
3319DD02575	G33575A	G33575A	19900620	0000	IGS (G33575A)	7.43	206.0+	1272	402^	7.8	18	28	125	569+	85	1.0	0.4
3319DD02576	G33576A	G33576A	19900620	0000	IGS (G33576A)	7.22	333.0^	1383	596^	15.1	49	59	113	406+	109	2.8^	0.4
3319DD02576	G33576A	G33576A	19900727	0000	IGS	8.38	329.0^	2124	562^	14.3	49	63	109	1093^	112	0.5	0.5
3319DD02576	G33576A	G33576A	19900900	0000	IGS	6.89	353.0^	2079	609^	14.5	51	59	110	1086^	116	0.7	0.4
3319DD02576	G33576A	G33576A	19901000	0000	IGS	8.07	357.0^	2331	697^	14.7	51	59	111	1255^	109	1.2+	0.4
3319DD02576	G33576A	G33576A	19910131	0000	IGS	7.23	362.0^	2150	665^	14.7	53	46	111	1102^	123	2.6^	0.4
3319DD02584	G33584A	G33584A	19900620	0000	IGS (G33584A)	7.38	282.0+	3697	1090^	37.9	51	104^	243	1850^	258+	1.5+	0.4
3319DD02584	G33584A	G33584A	19900727	0000	IGS	7.33	547.0^	3861	1279^	38.5	51	134^	161	1889^	262+	1.5+	0.4
3319DD02584	G33584A	G33584A	19901200	0000	IGS	6.97	1953.0^	13829^	3669^	24.3	245^	741^	26	8392^	699^	12.1^	3.2
3319DD02584	G33584A	G33584A	19910131	0000	IGS	7.82	615.0^	4186	1202^	36.8	53	102^	223	2099^	302+	2.3^	25.1^
3319DD02584	G33584A	G33584A	19910325	0000	IGS	8.44	599.0^	3686	1171^	38.9	54	107^	234	1804^	232+	0.2	0.2
3319DD02584	G33584A	G33584A	19910426	0000	IGS	8.64	595.0^	4600	1193^	25.2	13	58	234	1801^	228+	0.2	228.0^
3319DD02585	G33585A	G33585A	19900620	0000	IGS (G33585A)	7.35	1776.0^	14128^	3991^	103.6	345^	638^	440	7680^	820^	6.1^	0.2
3319DD02585	G33585A	G33585A	19900727	0000	IGS	7.27	1706.0^	15184^	4146^	121.9	354^	684^	504	8183^	1064^	5.8^	1.1
3319DD02585	G33585A	G33585A	19900900	0000	IGS	7.21	1996.0^	8713	185+	4.0	17	30	496	7809^	49	10.5^	0.7
3319DD02585	G33585A	G33585A	19901000	0000	IGS	7.38	2080.0^	15422^	4137^	109.0	363^	624^	492	8590^	980^	8.5^	0.6
3319DD02585	G33585A	G33585A	19901200	0000	IGS	7.34	2090.0^	15087^	4116^	93.8	358^	622^	497	8289^	984^	8.9^	0.8
3319DD02585	G33585A	G33585A	19910131	0000	IGS	7.22	1896.0^	14361^	4023^	104.5	344^	603^	493	7666^	996^	15.1^	0.7
3319DD02585	G33585A	G33585A	19910305	0000	IGS	7.99	2240.0^	14985^	3558^	117.1	454^	633^	376	8947^	814^	0.8	0.4
3319DD02585	G33585A	G33585A	19910426	0000	IGS	7.80	2250.0^	14672^	3528^	112.2	458^	629^	395	8659^	802^	0.8	0.2
3319DD02591	G33591A	G33593A	19900620	0000	IGS (G33591A)	7.60	146.0+	934	235+	7.6	38	35	123	364+	94	0.6	0.8
3319DD02591	G33591A	G33591A	19900700	0000	IGS	8.41	273.0+	1921	546^	7.0	57	57	214	758^	226+	0.6	0.5
3319DD02591	G33591A	G33591A	19910405	0000	IGS	8.48	683.0^	4225	1300^	19.0	69	88+	328	2010^	347+	0.9	0.5
3319DD03591	G33591B	G33591B	19900620	0000	IGS (G33591B)	7.86	542.0^	4290	1328^	19.2	70	96+	328	2036^	332+	1.0	0.3
3319DD03591	G33591B	G33591B	19900727	0000	IGS	8.70	644.0^	4648	1489^	20.1	69	101^	329	2167^	412+	1.4+	0.2
3319DD03591	G33591B	G33591B	19900900	0000	IGS	7.75	677.0^	4523	1355^	18.8	69	92+	329	2181^	398+	0.7	0.3
3319DD03591	G33591B	G33591B	19901000	0000	IGS	6.89	91.0+	2528	1633^	19.4	71	90+	77	213	397+	0.3	0.7
3319DD03591	G33591B	G33591B	19901200	0000	IGS	8.31	126.0+	743	195+	6.8	14	18	110	337+	31	0.7	1.3
3319DD03591	G33591B	G33591B	19910131	0000	IGS	8.33	684.0^	4675	1447^	20.1	71	91+	327	2220^	393+	2.5^	5.8+
3319DD03591	G33591B	G33591B	19910305	0000	IGS	9.02+	616.0^	3629	1173^	28.4	9	91+	255	1945^	99	1.4+	0.6

Site id	# on map	Sample #	Date	Time	Lab.	pH	EC mS/m	TDS () mg/L	Na mg/L	K mg/L	Ca mg/L	Mg mg/L	M.Alk mg/L	Cl mg/L	SO4 mg/L	P mg/L	NO3-N mg/L
3319DD03591	G33591B	G33591B	19910426	0000	IGS	9.00	609.0^	3639	1242^	29.0	11	84+	252	1907^	84	1.3+	0.7
3319DD04574	G33574C	G33574C	19900620	0000	IGS	8.15	454.0^	4509	1038^	40.3	131	241^	532	2203^	192	1.6^	0.6
3319DD04574	G33574C	G33574C	19900727	0000	IGS	8.37	654.0^	3947	127+	38.8	142	261^	607	2354^	270+	1.4+	0.7
3319DD04574	G33574C	G33574C	19900900	0000	IGS	8.05	723.0^	4607	1062^	37.3	151+	245^	447	2287^	260+	3.0^	1.0
3319DD04574	G33574C	G33574C	19901000	0000	IGS	7.80	718.0^	4980	1150^	41.8	155+	245^	446	2577^	243+	2.6^	1.4
3319DD04574	G33574C	G33574C	19901220	0000	IGS	7.85	718.0^	3624	637^	15.2	51	60	451	2189^	107	2.7^	1.3
3319DD04574	G33574C	G33574C	19910131	0000	IGS	7.75	687.0^	4560	1118^	37.0	135	226^	459	2225^	236+	6.9^	1.2
3319DD04574	G33574C	G33574C	19910305	0000	IGS	7.72	618.0^	3630	1179^	16.8	75	91+	39	2217^	2	0.8	0.2
3319DD04574	G33574C	G33574C	19910426	0000	IGS	6.81	618.0^	3708	1257^	17.5	84	93+	29	2217^	3	0.8	0.1
3320CC00101	H5M04		19871005	1630	HRI	7.10	35.2	182	41	1.3	8	9	21	68	25	0.2	0.4
3320CC00101	H5M04		19871012	1618	HRI	6.10	52.4	275	65	1.8	12	14	36	99	36	0.1	0.4
3320CC00101	H5M04		19871019	1525	HRI	6.38	58.2	305	73	1.9	13	15	41	110	39	0.1	0.3
3320CC00101	H5M04		19871026	1920	HRI	7.10	64.0	366	86	2.1	16	17	43	139	51	0.2	0.3
3320CC00101	H5M04		19871102	1657	HRI	7.70	88.0+	496	117+	2.6	20	23	77	173	65	0.3	0.1
3320CC00101	H5M04		19871109	1535	HRI	7.50	68.0	381	92	2.3	15	18	50	141	50	0.2	0.1
3320CC00101	H5M04		19871116	1600	HRI	7.50	92.0+	525	128+	2.7	21	25	66	203	63	0.2	0.1
3320CC00101	H5M04		19871123	1436	HRI	7.60	75.3+	393	95	2.6	16	18	50	144	55	0.2	0.1
3320CC00101	H5M04		19871130	1550	HRI	7.30	112.0+	611	150+	3.0	23	30	74	241	72	0.3	0.1
3320CC00101	H5M04		19871207	1453	HRI	7.50	114.0+	630	156+	3.6	24	28	80	248	71	0.2	0.0
3320CC00101	H5M04		19871214	1410	HRI	5.90-	24.9	120	27	1.4	5	6	12	48	15	0.1	0.2
3320CC00101	H5M04		19871221	1516	HRI	6.60	63.3	323	79	1.9	12	15	37	128	40	0.1	0.1
3320CC00101	H5M04		19871228	1454	HRI	7.30	79.0+	415	101+	2.4	16	20	47	166	50	0.3	0.2
3320CC00101	H5M04		19880104	1558	HRI	7.20	70.0	413	98	2.6	16	19	57	158	48	0.2	0.1
3320CC00101	H5M04		19880111	1555	HRI	7.10	91.0+	525	127+	3.0	19	24	70	203	62	0.2	0.1
3320CC00101	H5M04		19880118	1443	HRI	7.40	115.9+	618	153+	3.3	23	29	78	244	69	0.4	0.0
3320CC00101	H5M04		19880125	1515	HRI	7.40	185.6+	1143	286+	5.2	35	51	138	469+	128	0.3	0.0
3320CC00101	H5M04		19880201	1540	HRI	7.00	72.2+	366	93	4.4	13	16	40	145	45	0.2	0.0
3320CC00101	H5M04		19880208	1425	HRI	7.70	185.6+	1157	295+	5.0	38	54	132	472+	131	0.4	0.0
3320CC00101	H5M04		19880215	1410	HRI	7.10	64.0	364	90	1.9	13	17	42	145	45	0.2	0.0
3320CC00101	H5M04		19880222	1525	HRI	7.70	158.0+	862	218+	4.0	31	41	106	339+	98	0.4	0.0
3320CC00101	H5M04		19880229	1445	HRI	7.90	208.6+	1147	287+	5.8	40	51	133	473+	127	0.4	0.0
3320CC00101	H5M04		19880307	1450	HRI	7.50	160.9+	903	222+	4.4	34	41	118	366+	90	0.4	0.0
3320CC00101	H5M04		19880314	1356	HRI	7.90	219.4+	1230	288+	13.3	54	52	162	459+	158	0.4	0.1
3320CC00101	H5M04		19880321	1530	HRI	8.10	248.0+	1386	342+	7.5	51	62	167	565+	152	0.4	0.0
3320CC00101	H5M04		19880328	1650	HRI	7.60	264.0+	1545	381+	33.5	46	68	175	615^	186	0.6	0.0
3320CC00101	H5M04		19880404	1545	HRI	7.20	164.4+	954	223+	5.4	32	44	116	401+	104	0.4	0.1
3320CC00101	H5M04		19880411	1600	HRI	7.20	67.0	388	92	2.4	15	18	52	147	49	0.2	0.1
3320CC00101	H5M04		19880418	1608	HRI	7.60	104.0+	560	125+	2.6	24	30	77	210	72	0.2	0.1
3320CC00101	H5M04		19880502	1600	HRI	6.50	37.6	202	46	2.0	8	9	25	78	25	0.0	0.2
3320CC00101	H5M04		19880509	1610	HRI	6.90	69.9	376	87	2.5	15	17	48	140	52	0.1	0.3
3320CC00101	H5M04		19880516	1522	HRI	7.00	116.6+	631	157+	3.4	24	30	77	240	80	0.1	0.2
3320CC00101	H5M04		19880523	1653	HRI	5.70-	15.9	75	19	1.1	4	4	8	30	5	0.0	0.1
3320CC00101	H5M04		19880530	1615	HRI	5.60-	13.2	62	16	0.9	3	3	8	23	4	0.0	0.2
3320CC00101	H5M04		19880606	1605	HRI	5.20v	10.0	45	9	1.4	2	2	7	16	3	0.0	0.3
3320CC00101	H5M04		19880613	1535	HRI	6.30	20.4	107	24	1.3	5	5	10	41	14	0.0	0.6
3320CC00101	H5M04		19880620	1616	HRI	6.40	26.7	133	30	1.2	5	6	18	48	16	0.1	0.6
3320CC00101	H5M04		19880627	1640	HRI	6.70	37.5	196	45	1.7	8	9	23	72	27	0.1	0.7
3320CC00101	H5M04		19880704	1600	HRI	6.90	54.9	294	67	2.1	12	14	34	109	43	0.1	0.8

Site id	# on map	Sample #	Date	Time	Lab.	pH	EC mS/m	TDS () mg/L	Na mg/L	K mg/L	Ca mg/L	Mg mg/L	M.Alk mg/L	Cl mg/L	SO4 mg/L	F mg/L	NO3-N mg/L
3320CC00101	H5M04		19880711	1600	HRI	5.20v	9.7	52	10	0.7	3	2	7	18	7	0.0	0.2
3320CC00101	H5M04		19880718	1520	HRI	6.40	32.0	162	35	1.4	7	7	19	61	23	0.1	0.6
3320CC00101	H5M04		19880725	1626	HRI	5.90-	17.1	88	19	0.9	4	4	11	34	11	0.0	0.3
3320CC00101	H5M04		19880801	1640	HRI	6.60	46.0	240	57	1.5	10	11	29	86	35	0.1	0.6
3320CC00101	H5M04		19880808	1608	HRI	6.90	65.5	338	80	2.2	14	16	42	118	52	0.1	0.6
3320CC00101	H5M04		19880815	1552	HRI	6.60	35.5	181	42	1.3	8	8	22	66	26	0.1	0.3
3320CC00101	H5M04		19880822	1528	HRI	7.00	72.9+	404	93	2.6	17	18	50	152	57	0.0	0.4
3320CC00101	H5M04		19880829	1600	HRI	6.80	60.0	346	79	3.2	15	15	42	128	51	0.1	0.4
3320CC00101	H5M04		19880905	1620	HRI	6.10	20.9	95	21	1.2	5	5	9	36	12	0.0	0.4
3320CC00101	H5M04		19880912	1547	HRI	5.90-	17.0	84	17	0.8	4	4	10	32	11	0.1	0.4
3320CC00101	H5M04		19880919	1755	HRI	5.50-	13.5	65	13	0.8	4	3	7	27	6	0.0	0.2
3320CC00101	H5M04		19880926	1605	HRI	6.50	31.8	157	34	1.2	8	7	19	59	22	0.0	0.4
3320CC00101	H5M04		19881003	1638	HRI	6.20	23.5	116	27	1.0	5	6	12	45	14	0.1	0.3
3320CC00101	H5M04		19881010	1720	HRI	6.70	44.2	236	53	1.3	10	11	26	92	33	0.1	0.4
3320CC00101	H5M04		19881017	1617	HRI	6.80	67.4	325	72	1.7	13	15	41	124	46	0.1	0.4
3320CC00101	H5M04		19881024	1535	HRI	7.30	104.5+	576	134+	3.0	23	26	74	223	74	0.3	0.2
3320CC00101	H5M04		19881025	0745	HRI 10	7.30	86.0+	451	108+	2.4	19	22	56	173	58	0.7<	0.0
3320CC00101	H5M04		19881107	1640	HRI	7.10	53.0	310	72	1.9	13	15	40	118	40	0.1	0.1
3320CC00101	H5M04		19881114	1635	HRI	7.50	112.0+	641	152+	3.2	24	30	87	253+	71	0.2	0.1
3320CC00101	H5M04		19881121	1558	HRI	7.00	92.3+	494	117+	2.6	17	23	67	190	61	0.1	0.1
3320CC00101	H5M04		19881128	1623	HRI	7.10	102.2+	551	133+	2.6	18	26	74	217	64	0.2	0.0
3320CC00101	H5M04		19881205	1647	HRI	7.50	134.8+	797	188+	3.5	27	37	98	330+	89	0.5	0.1
3320CC00101	H5M04		19881212	1740	HRI	7.70	201.9+	1023	250+	4.7	33	49	134	405+	116	0.6	0.1
3320CC00101	H5M04		19881219	1715	HRI	7.10	110.0+	592	146+	3.4	21	27	74	235	68	0.4	0.1
3320CC00101	H5M04		19881226	1537	HRI	7.20	114.7+	655	162+	3.5	22	31	93	250	72	0.4	0.1
3320CC00101	H5M04		19890102	1626	HRI	6.90	105.2+	578	135+	3.8	23	27	80	222	68	0.2	0.0
3320CC00101	H5M04		19890109	1606	HRI	7.00	107.1+	583	137+	3.3	22	28	80	227	67	0.2	0.0
3320CC00101	H5M04		19890116	1608	HRI	7.80	126.0+	707	166+	3.6	25	35	94	286+	75	0.3	0.0
3320CC00101	H5M04		19890123	1656	HRI	7.60	103.7+	556	133+	3.5	20	27	73	221	61	0.3	0.1
3320CC00101	H5M04		19890130	1713	HRI	7.60	96.5+	510	121+	3.1	18	24	65	207	56	0.4	0.1
3320CC00101	H5M04		19890206	1730	HRI	7.20	118.4+	642	151+	3.4	22	30	85	260+	70	0.3	0.0
3320CC00101	H5M04		19890213	1613	HRI	7.10	115.3+	634	148+	3.3	22	29	88	255+	68	0.3	0.0
3320CC00101	H5M04		19890220	1730	HRI	7.80	254.1+	1384	345+	5.7	47	59	172	570+	146	0.4	0.0
3320CC00101	H5M04		19890227	1633	HRI	7.70	289.5+	1631	416^	8.7	53	72+	199	654^	181	0.5	0.0
3320CC00101	H5M04		19890306	1624	HRI	7.20	46.0	273	67	1.9	10	13	33	114	26	0.1	0.0
3320CC00101	H5M04		19890313	1640	HRI	8.00	178.0+	837	203+	4.7	28	38	110	343+	85	0.3	0.0
3320CC00101	H5M04		19890320	1535	HRI	6.80	44.1	264	59	2.4	10	12	39	103	27	0.1	0.1
3320CC00101	H5M04		19890327	1655	HRI	7.70	117.5+	736	175+	4.3	27	33	108	288+	73	0.3	0.1
3320CC00101	H5M04		19890403	1705	HRI	6.50	16.7	77	19	1.3	4	3	8	32	6	0.0	0.1
3320CC00101	H5M04		19890410	1600	HRI	7.50	76.5+	457	111+	2.7	17	19	67	175	48	0.1	0.1
3320CC00101	H5M04		19890417	1600	HRI	7.30	83.1+	540	133+	3.7	20	25	72	210	57	0.2	0.2
3320CC00101	H5M04		19890424	1735	HRI	7.10	41.9	244	56	4.6	12	11	29	88	33	0.1	0.4
3320CC00101	H5M04		19890426	1700	HRI 89617599	6.70	45.0	267	50	3.2	19	10	57	82	30	0.3	0.0
3320CC00101	H5M04		19890501	1505	HRI	8.20	75.6+	440	102+	3.8	18	19	55	168	58	0.2	0.3
3320CC00101	H5M04		19890508	1634	HRI	7.30	84.2+	506	117+	3.5	21	23	63	196	64	0.2	0.3
3320CC00101	H5M04		19890515	1540	HRI	6.70	13.0	74	16	1.2	4	3	8	31	7	0.0	0.1
3320CC00101	H5M04		19890522	1500	HRI	7.60	35.2	201	44	1.5	8	9	25	75	28	0.1	0.4
3320CC00101	H5M04		19890529	1540	HRI	7.80	46.8	265	63	1.8	10	13	36	103	27	0.1	0.3

Site id	# on map	Sample #	Date	Time	Lab.	pH	EC µS/m	TDS () mg/L	Na mg/L	K mg/L	Ca mg/L	Mg mg/L	M.Alk mg/L	Cl mg/L	SO4 mg/L	F mg/L	NO3-N mg/L
3320CC00101	H5M04		19890605	1545	HRI	7.20	16.4	91	19	0.8	4	4	14	36	8	0.1	0.2
3320CC00101	H5M04		19890612	1535	HRI	7.90	46.7	257	60	2.2	10	11	33	98	32	0.1	0.4
3320CC00101	H5M04		19890619	1530	HRI	7.20	60.9	382	89	3.2	15	17	50	140	50	0.1	0.3
3320CC00101	H5M04		19890626	1510	HRI	7.40	49.7	293	66	4.6	11	13	35	109	39	0.2	0.3
3320CC00101	H5M04		19890703	1640	HRI	7.50	21.7	139	30	1.7	6	6	18	54	15	0.0	0.5
3320CC00101	H5M04		19890710	1600	HRI	7.90	28.2	144	31	1.6	6	6	21	53	16	0.2	0.5
3320CC00101	H5M04		19890717	1606	HRI	7.40	31.7	176	40	1.8	8	8	19	66	25	0.1	0.5
3320CC00101	H5M04		19890724	1640	HRI	7.50	28.7	164	35	1.5	8	7	22	60	21	0.1	0.6
3320CC00101	H5M04		19890731	1620	HRI	7.50	28.3	166	36	1.5	8	8	22	61	21	0.1	0.5
3320CC00101	H5M04		19890814	1540	HRI	7.30	43.6	231	51	2.4	10	11	27	89	30	0.1	0.7
3320CC00101	H5M04		19890821	1554	HRI	7.20	21.5	109	22	1.4	5	5	16	42	11	0.0	0.4
3320CC00101	H5M04		19890828	1518	HRI	7.20	25.4	135	28	1.4	6	6	17	52	17	0.0	0.5
3320CC00101	H5M04		19890904	1625	HRI	7.30	24.1	118	25	1.6	6	6	14	45	13	0.0	0.7
3320CC00101	H5M04		19890907	1550	HRI	7.30	31.4	158	35	1.8	7	7	16	63	20	0.1	0.6
3320CC00101	H5M04		19890911	1620	HRI	7.00	21.7	128	24	1.7	6	6	16	47	16	0.2	0.0
3320CC00101	H5M04		19890918	1712	HRI	7.20	33.3	212	44	2.1	10	10	25	78	30	0.1	0.0
3320CC00101	H5M04		19890925	1610	HRI	7.00	20.0	121	23	1.3	6	5	16	44	14	0.1	0.0
3320CC00101	H5M04	H5M4	19900608	1150	IGS (AI)	6.80	13.0	97	21	1.6	5	4	12	33	12	0.5	0.7
3320CC00101	H5M04	H5M4	19900621	0852	IGS (H5M04)	7.66	55.0	361	84	3.7	18	16	45	130	47	0.1	1.1
3320CC00101	H5M04	H5M04	19900723	0000	IGS	6.92	34.0	237	55	2.2	12	11	30	79	33	0.3	1.1
3320CC00101	H5M04	SEC	19900900	0000	IGS	6.90	55.0	373	80	2.5	17	16	57	136	47	0.2	0.7
3320CC00101	H5M04	H5M04	19900906	1315	IGS	7.59	47.0	305	65	2.6	15	14	42	111	40	0.2	0.9
3320CC00101	H5M04	H5M4	19901025	0900	IGS	7.59	95.0+	632	139+	2.8	26	26	80	260+	74	0.5	1.0
3320CC00101	H5M04	SEC	19901130	0958	IGS	7.52	165.0+	1071	250+	3.8	36	46	137	430+	132	1.6^	0.6
3320CC00101	H5M04	SEC	19901206	0825	IGS	8.15	143.0+	1003	229+	50.0	36	40	121	389+	107	0.5	0.3
3320CC00101	H5M04	SEC	19901218	1018	IGS	6.49	19.0	134	29	0.7	8	6	17	46	20	0.0	0.5
3320CC00101	H5M04	SEC	19910322	1953	IGS	7.26	108.0+	676	166+	3.6	26	30	85	258+	85	0.7	0.5
3320CC00101	H5M04	SEC	19910212	0000	IGS	7.82	107.0+	1867	506^	8.0	63	81+	214	757^	185	0.4	0.5
3320CC00101	H5M04	SEC	19910301	1550	IGS	8.28	296.0+	1925	495^	8.3	60	82+	222	780^	219+	1.0	1.6
3320CC00101	H5M04	SEC	19910319	0000	IGS	7.93	134.0+	865	231+	5.0	35	37	110	336+	86	0.2	0.1
3320CC00101	H5M04	SEC	19910423	0000	IGS	8.47	230.0+	1501	376+	6.9	54	64	186	622^	155	0.5	0.4
3320CC00102	H3M11		19871005	1710	HRI	7.30	155.0+	885	215+	3.5	36	40	120	343+	98	0.5	0.3
3320CC00102	H3M11		19871012	1632	HRI	7.70	200.0+	1176	275+	3.9	45	54	153	473+	134	0.4	0.3
3320CC00102	H3M11		19871019	1717	HRI	8.10	400.0^	2447	597^	8.3	91	111^	285	976^	308+	0.7	0.6
3320CC00102	H3M11		19871027	0610	HRI	7.80	457.6^	2810	683^	8.1	101	128^	328	1138^	346+	0.8	0.4
3320CC00102	H3M11		19871102	1755	HRI	7.90	300.8^	1796	443^	8.7	58	84+	209	735^	208+	0.5	0.2
3320CC00102	H3M11		19871109	1618	HRI	8.10	396.8^	2363	584^	10.5	76	108^	266	990^	263+	0.7	0.3
3320CC00102	H3M11		19871116	1630	HRI	8.10	387.2^	2343	585^	7.8	77	108^	270	978^	253+	0.7	0.2
3320CC00102	H3M11		19871123	1630	HRI	7.80	281.6+	1681	421^	5.9	57	78+	195	695^	182	0.5	0.2
3320CC00102	H3M11		19871130	1707	HRI	8.00	486.8^	2994	732^	11.1	95	136^	306	1270^	369+	0.7	0.4
3320CC00102	H3M11		19871207	1530	HRI	8.00	448.7^	2696	669^	11.3	88	121^	297	1130^	305+	0.7	0.8
3320CC00102	H3M11		19871214	1525	HRI	8.10	477.9^	2938	720^	11.1	93	134^	309	1232^	362+	0.8	0.7
3320CC00102	H3M11		19871221	1550	HRI	8.10	514.1^	3197	791^	12.2	99	145^	327	1356^	388+	0.8	0.4
3320CC00102	H3M11		19871228	1556	HRI	7.80	274.5+	1596	386+	7.2	55	72+	188	654^	188	0.5	0.4
3320CC00102	H3M11		19880104	1644	HRI	7.90	317.4^	1774	444^	9.8	57	82+	186	726^	221+	0.5	0.6
3320CC00102	H3M11		19880111	1642	HRI	8.20	476.8^	2968	743^	11.1	101	138^	281	1284^	341+	0.7	0.4
3320CC00102	H3M11		19880118	1620	HRI	8.10	541.6^	3260	832^	9.6	90	153^	309	1391^	399+	0.9	0.4
3320CC00102	H3M11		19880125	1600	HRI	8.20	473.4^	2786	715^	9.0	78	131^	265	1200^	323+	0.7	0.3

171

Site id	# on map	Sample #	Date	Time	Lab.	pH	EC mS/m	TDS () mg/L	Na mg/L	K mg/L	Ca mg/L	Mg mg/L	M.Alk mg/L	Cl mg/L	SO4 mg/L	F mg/L	NO3-N mg/L
3320CC00102	H3M11		19880201	1610	HRI	8.20	466.8^	2780	703^	8.4	82	130^	264	1193^	333+	0.7	0.5
3320CC00102	H3M11		19880208	1520	HRI	8.50	494.9^	2967	744^	10.5	95	135^	297	1253^	356+	0.7	0.8
3320CC00102	H3M11		19880215	1500	HRI	8.30	429.4^	2574	642^	12.3	89	116^	340	1055^	234+	0.7	0.1
3320CC00102	H3M11		19880222	1630	HRI	8.20	286.8+	1620	397+	6.1	59	73+	175	685^	180	0.5	0.3
3320CC00102	H3M11		19880229	1530	HRI	8.10	267.5+	1498	368+	6.0	52	66	174	627^	161	0.5	0.4
3320CC00102	H3M11		19880307	1033	HRI	8.10	326.4^	1931	504^	8.4	69	86+	210	802^	198	0.5	0.3
3320CC00102	H3M11		19880314	1505	HRI	8.00	328.5^	1975	475^	12.7	81	85+	248	770^	236+	0.7	0.4
3320CC00102	H3M11		19880321	1640	HRI	8.30	450.0^	2762	681^	9.3	102	128^	315	1150^	298+	0.8	0.4
3320CC00102	H3M11		19880328	1615	HRI	8.30	465.3^	2925	729^	9.0	98	136^	318	1227^	328+	0.8	0.5
3320CC00102	H3M11		19880404	1605	HRI	8.50	463.7^	2797	711^	10.7	101	129^	317	1154^	290+	0.8	1.1
3320CC00102	H3M11		19880411	1620	HRI	8.30	400.7^	2357	578^	7.5	86	114^	274	994^	233+	0.7	0.6
3320CC00102	H3M11		19880418	1631	HRI	8.50	506.0^	3025	745^	9.3	104	149^	355	1278^	295+	0.9	0.6
3320CC00102	H3M11		19880425	1555	HRI	7.50	360.6^	2165	524^	8.7	81	99+	262	888^	235+	0.5	0.5
3320CC00102	H3M11		19880502	1630	HRI	7.40	234.0+	1290	316+	5.8	53	62	159	507+	146	0.3	0.3
3320CC00102	H3M11		19880509	1625	HRI	7.60	448.2^	2763	669^	9.0	104	127^	320	1148^	305+	0.7	0.9
3320CC00102	H3M11		19880516	1600	HRI	8.20	481.4^	2967	735^	12.1	114	141^	363	1224^	287+	0.9	0.8
3320CC00102	H3M11		19880523	1705	HRI	8.30	488.4^	3050	750^	11.2	106	141^	370	1283^	296+	1.0	0.9
3320CC00102	H3M11		19880530	1630	HRI	8.20	461.5^	2795	692^	10.4	106	133^	358	1137^	268+	0.9	0.9
3320CC00102	H3M11		19880606	1636	HRI	8.10	413.6^	2506	621^	9.6	99	119^	308	1021^	249+	0.8	0.9
3320CC00102	H3M11		19880613	1600	HRI	7.90	278.1+	1575	376+	6.9	67	76+	204	623^	169	0.6	0.7
3320CC00102	H3M11		19880620	1640	HRI	8.10	364.6^	2243	530^	8.7	95	106^	284	873^	276+	0.7	0.7
3320CC00102	H3M11		19880627	1700	HRI	8.40	353.6^	2150	504^	8.7	92	100+	277	840^	260+	0.7	0.7
3320CC00102	H3M11		19880704	1613	HRI	8.20	338.1^	1973	466^	8.0	76	89+	260	766^	244+	0.5	0.8
3320CC00102	H3M11		19880711	1618	HRI	8.20	264.4+	1638	387+	7.1	64	74+	223	632^	198	0.5	0.4
3320CC00102	H3M11		19880718	1538	HRI	7.90	224.6+	1234	290+	5.2	49	56	164	478+	151	0.4	0.6
3320CC00102	H3M11		19880725	1644	HRI	8.00	243.8+	1369	325+	5.2	55	62	187	521+	160	0.4	0.5
3320CC00102	H3M11		19880801	1650	HRI	7.80	341.5^	2006	471^	7.7	74	92+	248	811^	240+	0.7	0.8
3320CC00102	H3M11		19880808	1635	HRI	8.30	435.2^	2717	656^	7.9	101	125^	346	1087^	310+	1.0	0.9
3320CC00102	H3M11		19880815	1612	HRI	8.00	277.8+	1623	374+	5.3	59	73+	212	659^	190	0.6	0.4
3320CC00102	H3M11		19880822	1558	HRI	7.90	294.6+	1719	404^	6.8	59	78+	212	707^	200	0.6	0.7
3320CC00102	H3M11		19880829	1610	HRI	8.10	303.0^	1746	408^	12.2	64	76+	214	709^	208+	0.6	0.7
3320CC00102	H3M11		19880905	1640	HRI	7.50	146.2+	831	189+	3.7	36	38	117	321+	98	0.3	0.2
3320CC00102	H3M11		19880912	1610	HRI	8.10	204.8+	1302	296+	4.9	53	58	177	516+	155	0.3	0.3
3320CC00102	H3M11		19880919	1815	HRI	7.80	171.6+	1044	241+	4.1	44	47	147	400+	126	0.4	0.2
3320CC00102	H3M11		19880926	1638	HRI	8.10	249.6+	1590	371+	4.8	58	73+	216	619^	196	0.6	0.3
3320CC00102	H3M11		19881003	1655	HRI	8.30	441.6^	2748	645^	6.8	102	133^	335	1128^	319+	0.7	0.5
3320CC00102	H3M11		19881010	1740	HRI	7.90	362.2^	2278	537^	10.2	84	105^	285	918^	269+	0.6	0.7
3320CC00102	H3M11		19881017	1630	HRI	7.40	158.0+	932	225+	3.4	37	43	129	360+	104	0.3	0.2
3320CC00102	H3M11		19881024	1555	HRI	8.10	301.3^	1712	411^	5.1	62	77+	227	671^	205+	0.8	0.3
3320CC00102	H3M11		19881025	0730	HRI	7.90	278.0+	1571	377+	4.9	56	72+	197	646^	174	0.7<	0.0
3320CC00102	H3M11		19881031	1705	HRI	8.20	351.3^	2070	499^	5.7	76	94+	262	823^	247+	0.7	0.4
3320CC00102	H3M11		19881107	1730	HRI	8.30	429.8^	2678	657^	8.1	92	122^	333	1076^	310+	0.9	0.5
3320CC00102	H3M11		19881114	1705	HRI	8.30	391.1^	2369	579^	6.7	81	108^	291	960^	273+	0.8	0.4
3320CC00102	H3M11		19881121	1655	HRI	8.00	421.2^	2513	610^	9.5	86	119^	309	1025^	279+	0.9	0.5
3320CC00102	H3M11		19881128	1600	HRI	8.20	482.8^	2985	750^	10.9	93	143^	348	1247^	307+	0.9	0.5
3320CC00102	H3M11		19881205	1657	HRI	8.60	530.5^	3337	836^	11.5	105	161^	368	1418^	347+	1.0	0.6
3320CC00102	H3M11		19881212	1815	HRI	8.40	528.4^	3407	852^	10.4	105	163^	378	1412^	394+	1.1+	0.8
3320CC00102	H3M11		19881219	1130	HRI	7.90	380.7^	2188	548^	20.0	68	100+	252	908^	228+	0.7	0.8

Site id	# on map	Sample #	Date	Time	Lab.	pH	EC mS/m	TDS () mg/L	Na mg/L	K mg/L	Ca mg/L	Mg mg/L	M.Alk mg/L	Cl mg/L	SO4 mg/L	F mg/L	NO3-N mg/L
3320CC00102	H3M11		19890102	1730	HRI	8.00	249.6+	1520	357+	7.8	62	69	228	589+	150	0.6	0.3
3320CC00102	H3M11		19890109	1655	HRI	8.40	502.4^	3138	766^	11.3	108	146^	380	1311^	320+	0.9	0.6
3320CC00102	H3M11		19890116	1630	HRI	8.10	496.0^	3097	770^	13.5	99	141^	361	1304^	318+	0.9	0.7
3320CC00102	H3M11		19890123	1715	HRI	8.20	531.2^	3286	827^	14.0	105	150^	373	1398^	327+	1.0	0.3
3320CC00102	H3M11		19890130	1730	HRI	7.80	500.0^	3400	858^	11.8	92	156^	368	1466^	354+	1.0	0.5
3320CC00102	H3M11		19890206	1800	HRI	8.70	525.0^	3519	883^	11.6	96	169^	360	1507^	404+	0.9	0.3
3320CC00102	H3M11		19890213	1637	HRI	8.40	381.0^	2450	604^	9.6	77	118^	279	1031^	261+	0.7	0.5
3320CC00102	H3M11		19890220	1750	HRI	8.60	476.0^	3212	801^	11.6	96	154^	364	1333^	361+	0.8	0.5
3320CC00102	H3M11		19890227	1654	HRI	8.50	448.0^	2956	733^	13.5	95	143^	365	1216^	297+	0.8	0.7
3320CC00102	H3M11		19890306	1640	HRI	8.60	329.0^	2137	527^	8.5	67	101^	260	879^	220+	0.6	0.5
3320CC00102	H3M11		19890313	1655	HRI	8.30	420.0^	2721	678^	18.0	88	117^	319	1133^	285+	0.7	0.9
3320CC00102	H3M11		19890320	1548	HRI	8.50	324.0^	2026	480^	8.1	67	94+	272	816^	218+	0.6	0.6
3320CC00102	H3M11		19890327	1715	HRI	8.20	170.0+	991	238+	4.9	37	45	139	392+	98	0.3	0.2
3320CC00102	H3M11		19890403	1715	HRI	8.00	181.0+	1225	299+	5.8	42	52	164	498+	122	0.4	0.3
3320CC00102	H3M11		19890410	1610	HRI	8.10	194.0+	1264	307+	5.3	44	52	171	520+	120	0.4	0.3
3320CC00102	H3M11		19890417	1615	HRI	8.20	274.0+	1754	424^	8.6	61	79+	232	711^	179	0.5	0.5
3320CC00102	H3M11		19890424	1745	HRI	7.90	148.0+	890	207+	10.5	38	37	139	327+	91	0.3	0.8
3320CC00102	H3M11		19890426	1630	HRI 89617587	7.10	188.0+	1195	294+	10.8	43	52	183	436+	129	0.4	0.1
3320CC00102	H3M11		19890501	1540	HRI	8.00	238.0+	1470	345+	8.4	56	68	198	587+	156	0.4	0.4
3320CC00102	H3M11		19890508	1700	HRI	8.00	335.0^	2149	523^	11.0	82	102^	274	874^	214+	0.6	0.6
3320CC00102	H3M11		19890515	1605	HRI	8.10	315.0^	1989	476^	8.1	67	91+	244	830^	210+	0.6	0.7
3320CC00102	H3M11		19890522	1540	HRI	8.70	416.0^	2846	674^	11.9	103	135^	355	1204^	274+	0.8	0.8
3320CC00102	H3M11		19890529	1615	HRI	8.70	422.0^	2960	706^	11.6	108	138^	376	1218^	307+	0.8	1.0
3320CC00102	H3M11		19890605	1610	HRI	8.70	431.0^	3082	738^	11.6	107	144^	398	1266^	317+	0.8	1.0
3320CC00102	H3M11		19890612	1600	HRI	8.70	292.0+	1944	478^	7.5	69	94+	253	763^	215+	0.6	0.8
3320CC00102	H3M11		19890619	1600	HRI	8.70	390.0^	2670	632^	10.4	97	124^	348	1088^	284+	0.7	0.8
3320CC00102	H3M11		19890626	1500	HRI	8.50	204.0+	1244	307+	9.3	46	54	173	487+	122	0.7	0.5
3320CC00102	H3M11		19890703	1640	HRI	8.00	235.0+	1491	355+	8.0	54	67	218	582+	152	0.6	0.5
3320CC00102	H3M11		19890710	1627	HRI	8.10	287.0+	1957	466^	10.4	72	88+	289	733^	227+	0.7	0.6
3320CC00102	H3M11		19890717	1635	HRI	8.20	213.0+	1327	314+	7.3	50	60	197	511+	140	0.5	0.4
3320CC00102	H3M11		19890724	1707	HRI	8.20	217.0+	1360	325+	6.6	50	61	200	527+	143	0.5	0.3
3320CC00102	H3M11		19890731	1645	HRI	8.10	194.0+	1205	281+	6.0	46	54	167	478+	132	0.4	0.4
3320CC00102	H3M11		19890807	1630	HRI	8.60	194.0+	1150	292+	6.0	39	50	163	449+	111	0.4	0.4
3320CC00102	H3M11		19890814	1605	HRI	8.30	205.0+	1202	295+	6.1	41	53	166	482+	116	0.4	0.6
3320CC00102	H3M11		19890821	1620	HRI	8.60	206.0+	1213	291+	5.8	41	53	166	496+	120	0.4	0.3
3320CC00102	H3M11		19890828	1545	HRI	8.20	231.0+	1278	317+	7.2	42	61	159	533+	119	0.4	0.5
3320CC00102	H3M11		19890904	1650	HRI	8.20	185.0+	1124	278+	5.2	39	49	165	440+	108	0.3	0.3
3320CC00102	H3M11	H3M11	19900608	1120	IGS (AH)	8.02	260.0+	1735	398+	7.5	64	75+	237	707^	183	2.5^	0.9
3320CC00102	H3M11	H3M11	19900621	1013	IGS (H3M11)	8.10	278.0+	1845	442^	9.1	72	83+	243	723^	209+	0.9	1.0
3320CC00102	H3M11	H3M11	19900723	0000	IGS	7.84	209.0+	1494	359+	5.7	57	67	207	578+	168	0.9	0.8
3320CC00102	H3M11	H3M11	19900906	1245	IGS	8.21	253.0+	1652	394+	6.1	63	74+	230	647^	178	2.6^	0.7
3320CC00102	H3M11	H3M11	19900925	1530	IGS	7.83	319.0^	2152	505^	7.1	75	90+	297	861^	244+	1.1+	0.8
3320CC00102	H3M11	H3M11	19901025	0947	IGS	8.10	432.0^	3090	744^	9.0	98	124^	367	1308^	347+	2.1^	1.1
3320CC00102	H3M11	H3M11	19901130	0930	IGS	7.81	362.0^	2558	630^	9.2	77	109^	306	1054^	292+	3.5^	1.1
3320CC00102	H3M11	H3M11	19901206	0810	IGS	7.85	316.0^	2182	541^	9.3	75	91+	247	920^	235+	2.7	0.8
3320CC00102	H3M11	H3M11	19901218	0930	IGS	7.48	275.0+	1955	490^	11.1	65	82+	213	784^	253+	2.3^	0.5
3320CC00102	H3M11	H3M11	19910122	1011	IGS	7.82	451.0^	3198	806^	12.4	101	136^	354	1315^	382+	1.9^	1.1
3320CC00102	H3M11	H3M11	19910212	0000	IGS	7.66	111.0+	2176	563^	10.4	72	92+	238	914^	223+	1.3+	0.9

173

Site id	# on map	Sample #	Date	Time	Lab.	pH	EC mS/m	TDS () mg/L	Na mg/L	K mg/L	Ca mg/L	Mg mg/L	H.Alk mg/L	Cl mg/L	SO4 mg/L	F mg/L	NO3-N mg/L
3320CC00102	H3M11	H3M11	19910301	1520	IGS	8.28	414.0^	2708	701^	10.9	82	112^	286	1160^	282+	2.0^	0.4
3320CC00102	H3M11	H3M11	19910319	0000	IGS	7.93	355.0^	2347	605^	13.7	80	102^	245	998^	246+	0.3	0.7
3320CC00102	H3M11	H3M11	19910423	0000	IGS	8.55	419.0^	2758	676^	11.3	97	120^	327	1178^	286+	0.9	1.1

Selected standard : SA drinking water- humans

^ = Exceeds max acceptable value - = Below min guideline value
 + = Exceeds max guideline value v = Below min acceptable value
 < = Below detection limit

Appendix 6

Chemical analyses:
Micro elements

Site id	# on map	Sample #	Date	NO2-N mg/L	Al mg/L	Ba mg/L	B mg/L	Br mg/L	Cu mg/L	Fe mg/L	Mn mg/L	PO4 mg/L	Si mg/L	Sr mg/L	Zn mg/L	Temp. C	TDS () mg/L	Ion-ba l
3319CB00100	H1R01Y	A	19900530	0.00	0.03	0.015	0.013	0.00	0.022	0.48+	0.025<		2.5	0.043	0.047	15.4	82	6.98
3319CB00100	H1R01Y	H1R01Y	19900903	0.00	0.00	0.010	0.013<	0.06	0.020<	0.31+	0.000		1.4	0.023	0.017		87	1.48
3319CB00100	H1R01Y	H1R01Y	19901202		0.08<	0.013	0.013	0.07	0.020<	0.73+	0.025<		0.6	0.047	0.086		99	3.85
3319CB00100	H1R01Y	A	19910226	0.00	0.08<	0.011	0.013<	0.13	0.020<	0.40+	0.109+		0.5	0.045	0.016		100	-0.32
3319CB00101	BV	BV	19901202	0.00	0.08<	0.013	0.013	0.03	0.020<	0.75+	0.025	0.00	0.6	0.047	0.086		34	10.09
3319CB00101	BV	BV	19910226	0.00	0.08	0.011	0.013<	0.00	0.020<	0.21+	0.025<		0.4	0.013	0.015		40	8.66
3319CB00102	R1		19881024			0.026							1.7	0.075			121	9.23
3319CB00102	R1		19890425			0.009						0.03	1.7	0.055			108	1.80
3319CD00026	JF01	JF01	19900607	0.01	0.08<	0.039	0.013<	0.17	0.020<	2.29*	0.341+	0.00	15.4	0.243	0.268	19.0	422	1.65
3319CD00027	JF02	JF02	19900607	0.01	0.08<	0.035	0.013<	0.09	0.023	1.04*	0.336+		10.1	0.173	0.975		255	3.70
3319CD00101	H4R04U	H4R04U	19881024			0.037							0.0	0.021			27	28.42
3319CD00101	H4R04U	H4R04U	19890425			0.021						0.02	0.4	0.022			50	-6.58
3319CD00101	H4R04U	H4R04U	19900530	0.00	0.11	0.014	0.013<	0.00	0.026	0.24+	0.025<	0.00	0.9	0.018	0.041	16.0	47	7.79
3319CD00101	H4R04U	H4R04U	19900903	0.00	0.14	0.236	0.013	0.04	0.020<	0.27+	0.025<		0.2	0.114	0.047		38	8.06
3319CD00101	H4R04U	H4R04U	19901202	0.00	0.13	0.012	0.013<	0.00	0.020<	0.58+	0.025<		0.3	0.018	0.077		38	8.20
3319CD00101	H4R04U	2	19910226	0.00	0.08<	0.011	0.013<	0.00	0.020<	0.20+	0.025<		0.3	0.015	0.010		40	9.52
3319CD00102	C2		19881024			0.034							1.7	0.036			55	5.26
3319CD00102	C2		19890425			0.009						0.06	1.6	0.032			68	7.11
3319DA00002	NG01	NG1	19900605	0.00	0.08<	0.006	0.013<	0.00	0.020<	0.62+	0.182+	0.00	6.1	0.030	0.024	17.0	100	-1.55
3319DA00003	NG02	NG2	19900605	0.00	0.08<	0.006	0.013<	0.00	0.020<	0.96+	0.038	0.00	6.1	0.025	0.028	16.5	74	10.78
3319DA00003	NG02	NG2	19910301	0.00	0.08<	0.197	0.073	0.76	0.020<	0.45+	0.025<		6.6	1.250	0.028		888	0.96
3319DA00004	NG03	NG3	19900605	0.00	0.08<	0.003	0.013<	0.00	0.028	1.49*	0.025<	0.00	6.2	0.008	0.050	17.5	56	7.01
3319DA00004	NG03	NG3	19900905	0.00	0.08<	0.002	0.013	0.00	0.020<	0.02<	0.025<		6.2	0.010	0.011		89	-28.36
3319DA00004	NG03	NG3	19901200	0.00	0.08<	0.002	0.013<	0.00	0.020<	0.15+	0.020<		6.1	0.010	0.030		67	5.95
3319DA00004	NG03	NG3	19910301	0.00	0.08<	0.004	0.013<	0.00	0.020<	10.61*	0.078+		3.6	0.006	0.062		61	21.24
3319DA00005	NG04	NG4	19900605	0.00	0.08<	0.007	0.013<	0.00	0.020<	0.72+	0.025<	0.00	6.5	0.010	0.454	17.7	52	8.97
3319DA00005	NG04	NG4	19900905	0.00	0.08<	0.002	0.013<	0.00	0.020<	0.02<	0.025<		6.6	0.010	0.011		51	1.49
3319DA00005	NG04	NG4	19901200	0.00	0.08<	0.002	0.013<	0.00	0.020<	0.17+	0.025<		6.9	0.010	0.114		62	-7.79
3319DA00005	NG04	NG4	19910301	0.00	0.03	0.003	0.013<	0.08	0.020<	0.21+	0.025<		6.6	0.006	0.378		50	6.15
3319DA00006	NG05	NG5	19900605	0.00	0.08<	0.003	0.013<	0.00	0.020<	0.07	0.025<	0.00	6.3	0.008	0.041	17.5	47	3.94
3319DA00006	NG05	NG5	19900905	0.00	0.08<	0.002	0.013<	0.00	0.020<	0.02<	0.025<		6.4	0.012	0.300		44	1.75
3319DA00006	NG05	NG5	19901200	0.00	0.08<	0.002<	0.013<	0.00	0.020<	0.13+	0.025<		6.4	0.005	0.040		41	9.73
3319DA00006	NG05	NG5	19910301	0.00	0.08<	0.004	0.013<	0.00	0.020<	0.20+	0.025<		6.3	0.007	0.025		47	7.09
3319DA00007	NG06	NG6	19900605	0.00	0.08<	0.008	0.013<	0.00	0.020	0.21+	0.025<	0.00	6.3	0.026	0.347	17.0	47	5.60
3319DA00008	VR01	VR1	19900605	0.00	0.08<	0.139	0.062	0.78	0.020<	0.25+	0.027	0.00	4.8	1.161	0.216	12.0	831	0.62
3319DA00008	VR01	VR1	19900903	0.20	0.08<	0.140	0.112	1.00	0.000	0.03	0.025<		5.9	1.833	0.013		1007	0.57
3319DA00008	VR01	VR1	19901203	0.00	0.08<	0.159	0.104	0.97	0.020<	0.44+	0.025<		5.8	1.320	0.080		977	0.38
3319DA00008	VR01	VR01	19910226	0.00	0.08<	0.151	0.086	0.13	0.020<	0.17+	0.025<	0.00	5.6	1.295	0.013		920	1.38
3319DA00101	R33		19881024			0.102							7.7	0.828			2075	0.61
3319DA00101	R33		19890425			1.060*						3.11	4.1	0.190			219	-0.33
3319DA00102	SMIT	SMIT	19900605	0.01	0.08<	0.025	0.368	0.23	0.020<	0.07	0.025<	0.00	11.1	0.176	0.244		643	0.54
3319DA00103	MCG	MCG	19900605	0.65	0.08<	0.087	0.292	2.56	0.060	0.13+	0.238+	0.00	7.0	6.802	7.088*		2140	-2.02
3319DA00104	NGF	NGF	19900605	0.00	0.08<	0.006	0.013<	0.00	0.020<	0.20+	0.025<	0.00	5.5	0.015	0.016	14.0	47	3.82
3319DB00005	KD01	KD1	19900531	0.00	0.08<	0.010	0.060	0.75	0.020	7.23*	0.328+	0.00	6.8	0.608	0.031	24.0	962	-2.00
3319DB00005	KD01	KD1	19900903	0.02	0.08<	0.009	0.034	0.18	0.020<	4.93*	0.152+		11.6	0.255	0.028		901	0.73
3319DB00005	KD01	KD1	19901203	0.00	0.08<	0.009	0.114	0.73	0.020<	4.78*	0.146+		11.4	0.616	0.098	20.0	902	1.06
3319DB00005	KD01	KD1	19910226	0.00	0.08<	0.007	0.085	1.18	0.020<	5.81*	0.155+		10.7	0.598	0.009		906	-0.81
3319DB00007	KD03	KD3	19900531	0.00	0.08<	0.010	0.013	0.37	0.022	2.38*	0.267+	0.00	6.2	0.509	0.070	19.0	531	2.17

175

Site id	# on map	Sample #	Date	NO2-N mg/L	Al mg/L	Ba mg/L	B mg/L	Br mg/L	Cu mg/L	Fe mg/L	Mn mg/L	PO4 mg/L	Si mg/L	Sr mg/L	Zn mg/L	Temp. C	TDS () mg/L	Ion-ba %
3319DB00007	KD03	KD3	19900903	0.19	0.08<	0.007	0.106	0.78	0.020<	1.29^	0.230+		8.4	0.807	0.012	19.0	569	1.37
3319DB00007	KD03	KD3	19901203	0.00	0.08<	0.010	0.062	0.37	0.020<	0.31+	0.098+		12.8	0.620	0.043	21.0	501	1.59
3319DB00007	KD03	KD3	19910226	0.00	0.08<	0.008	0.043	0.42	0.020<	0.26+	0.124+		12.7	0.636	0.027	20.0	574	-2.64
3319DB00008	NE07	NE7	19890500		0.08<	0.013<	0.014		0.020<	0.95+	0.471+		19.7	0.249	0.092		529	1.10
3319DB00009	NE05	NE5	19900531	0.05	0.08<	0.009	0.013<	0.00	0.020<	3.03^	0.148+	0.00	6.5	0.120	0.139	17.0	116	7.79
3319DB00011	NE03	NE3	19881024			0.520+							1.0	0.807			207	-0.14
3319DB00011	NE03	NE3	19890425			0.004<						0.04	3.4	0.003			59	-11.56
3319DB00011	NE03	NE3	19900531	0.00	0.08<	0.018	0.013<	1.14	0.088	4.08^	0.066+	0.00	1.2	0.918	0.048	15.5	731	-4.15
3319DB00011	NE03	NE3	19900903	0.17	0.08<	0.027	0.146	1.11	0.020<	0.94+	0.136+		13.7	2.442	0.093		1224	-0.90
3319DB00011	NE03	NE3	19901200	0.00	0.08<	0.025	0.040	1.08	0.020<	0.15+	0.031		4.7	1.669	0.014		941	-2.43
3319DB00011	NE03	NE3	19910301	0.00	0.08<	0.008	0.013<	0.09	0.020<	0.11+	0.029		5.6	0.082	0.057		66	10.05
3319DB00012	NE02	NE2	19900531	0.00	0.12	0.016	0.018	0.30	0.021	7.61^	0.107+	0.00	12.6	0.303	0.158	15.0	407	2.62
3319DB00012	NE02	NE2	19900903	0.01	0.08<	0.006	0.062	0.40	0.020<	0.46+	0.059+		11.4	0.765	0.016		387	-1.15
3319DB00012	NE02	NE2	19901200	0.00	0.08<	0.010	0.013<	0.13	0.020<	0.15+	0.048		11.4	0.435	0.007		341	0.10
3319DB00012	NE02	NE2	19910301	0.00	0.08<	0.016	0.013<	0.29	0.020<	0.20+	0.116+		12.5	0.615	0.058		406	0.50
3319DB00013	NE01	NE1	19900531	0.03	0.08<	0.038	0.114	1.06	0.023	5.55^	0.368+	0.00	13.3	1.979	0.506	15.5	1256	-1.26
3319DB00013	NE01	NE1	19900903	0.00	0.02<	0.011	0.029	0.25	0.020<	1.37^	0.324+		14.3	0.552	0.083		1203	-0.97
3319DB00013	NE01	NE1	19901200	0.00	0.08<	0.021	0.089	0.76	0.020<	0.15+	0.197+		12.2	1.366	0.061		939	-1.53
3319DB00013	NE01	NE1	19910301	0.00	0.08<	0.035	0.123	1.19	0.020<	0.15+	0.436+		13.0	2.113	0.311		1415	-0.68
3319DB00016	NE08	NE8	19900605	0.00	0.08<	0.025	0.057	0.29	0.020<	3.30^	0.430+	0.00	7.5	0.473	0.061	15.2	593	9.17
3319DB00016	NE08	NE08	19900903	0.02	0.08<	0.140	0.112	1.01	0.020<	0.07	0.025<		7.4	1.833	0.013		367	1.76
3319DB00016	NE08	NE8	19901203	0.00	0.08<	0.018	0.063	0.18	0.020<	0.29+	0.275+		7.9	0.455	0.036	20.0	633	1.64
3319DB00016	NE08	NE8	19910226	0.00	0.08<	0.020	0.032	0.33	0.020<	1.02^	0.498+		8.0	0.497	0.018		699	-1.70
3319DB00102	F1	F1	19881024			0.017							2.4	0.034			36	2.97
3319DB00102	F1	F1	19890425			0.004<						0.03	11.3	1.295			1060	-2.27
3319DB00102	F1	F1	19900531	0.00	0.08<	0.005	0.013<	0.00	0.020	0.03	0.025<	0.00	3.5	0.036	0.050		52	18.47
3319DB00102	F1	F1	19900903	0.00	0.08<	0.005	0.013<	0.00	0.020<	0.06	0.025<		3.8	0.046	0.044		56	11.52
3319DB00102	F1	F1	19901200	0.00	0.08<	0.002	0.013<	0.00	0.020<	0.16+	0.025<		3.9	0.025	0.005<		95	-20.98
3319DB00102	F1	F1	19910226	0.00	0.08<	0.004	0.013<	0.00	0.022	0.20+	0.025<		4.4	0.030	0.028		52	9.33
3319DB00103	H	H	19900531	0.00	0.15	0.011	0.013<	0.23	0.020<	0.46+	0.025<	0.00	11.9	0.058	0.057		199	3.81
3319DB00104	K	K	19900531	0.00	0.08<	0.021	0.013<	0.47	0.020<	12.54^	0.105+	0.00	0.5	0.291	0.058	19.0	408	4.52
3319DB00105	L	L	19900531	0.91	0.08<	0.031	0.013<	0.06	0.020<	0.64+	0.150+	0.00	2.7	0.350	0.020	20.0	242	3.43
3319DB00106	M	M	19900531	0.03	0.08<	0.015	0.013<	0.03	0.020<	0.19+	0.025<	0.00	6.2	0.350	0.055	20.0	231	0.94
3319DB00107	KD2A	KD2A	19900531	0.02	0.08<	0.004	0.053	0.17	0.020<	0.12+	0.025<	0.00	9.7	0.148	0.033	16.8	364	2.37
3319DB00107	KD2A	KD2A	19901203	0.00	0.08<	0.035	0.013<	0.08	0.020<	0.26+	0.773+		16.1	0.054	0.123	21.0	315	5.53
3319DB00107	KD2A	KD2A	19910226	0.00	0.08<	0.002	0.057	0.11	0.015	0.09	0.025<		10.4	0.124	0.023		322	-1.59
3319DC00002	DN02		19881025			0.120							13.4	0.078			109	2.53
3319DC00002	DN02		19890426			0.004<						0.15	14.1	0.390			732	-1.87
3319DC00006	DN06	DN6	19890426			0.004<						0.02	6.7	0.001<			102	-6.93
3319DC00006	DN06	DN6	19900601	0.00	0.08<	0.067	0.013<	0.10	0.020<	0.06	0.025<	0.00	6.8	0.032	0.179	24.0	108	5.48
3319DC00006	DN06	DN6	19900905	0.00	0.08<	0.058	0.013<	0.05	0.020<	0.02	0.025<		7.5	0.033	0.050	26.8+	144	-19.16
3319DC00006	DN06	DN6	19901205	0.00	0.08<	0.070	0.013	0.06	0.020<	0.23+	0.025<		7.3	0.033	0.087		114	-0.85
3319DC00006	DN06	DN6	19910227	0.00	0.08<	0.064	0.013<	0.13	0.020<	0.04	0.025<		6.9	0.023	0.032	25.5+	99	-2.61
3319DC00007	DN07	DN7	19881025			0.056							15.7	0.664			1110	0.43
3319DC00007	DN07	DN7	19890426			0.004<						0.02	16.5	0.629			1072	0.24
3319DC00007	DN07	DN7	19900601	0.09	0.08<	0.018	0.050	0.94	0.021	0.21+	0.197+	0.00	16.3	0.542	0.135	21.0	1077	-2.24
3319DC00007	DN07	DN7	19900905	0.26	0.08<	0.011	0.114	0.98	0.020<	0.18+	0.199+		18.8	0.377	0.065	21.1	1091	0.15
3319DC00007	DN07	DN7	19901205	0.00	0.08<	0.024	0.064	0.79	0.020<	0.39+	0.193+		18.3	0.543	0.143		1112	-2.44

176

Site id	# on map	Sample #	Date	NO2-N mg/L	Al mg/L	Ba mg/L	B mg/L	Br mg/L	Cu mg/L	Fe mg/L	Mn mg/L	PO4 mg/L	Si mg/L	Sr mg/L	Zn mg/L	Temp. C	TDS () mg/L	Ion-ba %
3319DC00007	DN07	DN7	19910227	0.00	0.08<	0.016	0.034	0.92	0.020<	0.29+	0.241+		17.4	0.585	0.043	22.2	1143	-4.35
3319DC00008	DN08	DN8	19900601	0.08	0.08<	0.018	0.061	0.97	0.020<	0.60+	0.110+	0.00	10.4	0.260	0.210	20.5	1096	8.16
3319DC00008	DN08	DN8	19900630	0.00	0.08<	0.002<	0.013<	0.00	0.020<	0.04	0.054+		10.1	0.008	0.019		1030	-0.22
3319DC00008	DN08	DN8	19900905	0.00	0.08<	0.073	0.013	0.07	0.020<	0.02<	0.025<		10.5	0.056	0.042	16.0	1085	0.36
3319DC00008	DN08	DN8	19901205	0.00	0.08<	0.021	0.117	1.08	0.020<	0.33+	0.025<		10.1	0.303	0.090		1107	-1.55
3319DC00008	DN08	DN8	19910227	0.00	0.80<	0.016	0.095	1.31	0.020<	0.05	0.025<		9.7	0.317	0.050	25.0	1105	-2.02
3319DC00010	PR01	PR1	19900601	0.00	0.08<	0.043	0.013<	0.42	0.022	2.43^	0.801+	0.00	9.2	0.239	0.364	16.0	649	-0.05
3319DC00010	PR01	PO1	19900905	1.40	0.08<	0.076	0.231	4.51	0.020<	4.15^	0.861+		13.9	4.259	0.038	22.8	558	2.49
3319DC00010	PR01	PR1	19901205	0.00	0.08<	0.043	0.013<	0.00	0.020<	2.08^	0.472+		7.3	0.145	5.691^		628	-6.46
3319DC00010	PR01	PR1	19910227	0.00	0.08<	0.033	0.013<	0.44	0.020<	0.31+	0.848+		10.4	0.241	0.132		586	-2.13
3319DC00027	PR18	PR18	19900602	0.00	0.08<	0.023	0.013<	0.05	0.020<	0.08	0.025<	0.00	5.6	0.019	0.512		77	5.44
3319DC00027	PR18	PR18	19900905	0.12	0.08<	0.034	0.021	0.48	0.020<	0.03	0.025<		6.1	0.315	0.243	21.9	73	1.80
3319DC00027	PR18	PR18	19901205	0.00	0.08<	0.016	0.013<	0.00	0.020	0.14+	0.025<		5.9	0.019	0.056		78	3.31
3319DC00027	PR18	PR18	19910227	0.00	0.08<	0.013	0.013<	0.12	0.020<	0.10	0.025<		5.7	0.010	0.021	22.3	65	4.35
3319DC00028	PY01	PY1	19900604	0.00	0.17+	0.037	0.013<	0.13	0.020<	0.36+	0.167+	0.00	12.1	0.055	0.036		201	2.38
3319DC00028	PY01	PY1	19900907	0.06	0.08<	0.018	0.013<	0.28	0.020<	0.61+	0.123+		16.9	0.086	0.038	18.2	134	2.78
3319DC00028	PY01	PY1	19901206	0.00	0.08<	0.026	0.013<	0.00	0.021	0.27+	0.181+		16.5	0.041	0.522		135	4.35
3319DC00028	PY01	PY1	19910305	0.00	0.08<	0.027	0.013<	0.07	0.020<	0.11+	0.166+		14.0	0.676	0.448		151	-2.21
3319DC00030	RY01	RY1	19900604	0.07	0.08<	0.116	0.013<	0.38	0.020<	0.06	1.588^	0.00	8.4	0.106	0.074		394	2.78
3319DC00030	RY01	RY1	19900907	0.12	0.08<	0.071	0.013<	0.35	0.020<	0.29+	0.508+		8.5	0.555	0.031		213	1.93
3319DC00030	RY01	RY1	19901206	0.00	0.08<	0.027	0.013<	0.00	0.020<	0.35+	0.037		6.7	0.041	0.182		114	6.44
3319DC00030	RY01	RY1	19910305	0.00	0.08	0.045	0.013<	0.19	0.020<	0.15+	0.379+		7.5	0.035	0.041		163	3.13
3319DC00033	RY04	RY4	19900604	0.08	0.32+	0.139	0.019	0.30	0.020<	0.51+	0.068+	0.00	3.3	0.089	0.025		345	0.91
3319DC00033	RY04	RY4	19900907	0.00	0.08<	0.017	0.013<	0.10	0.020<	0.25+	0.486+		9.4	0.040	0.420		339	0.47
3319DC00033	RY04	RY4	19901206	0.00	0.08<	0.059	0.025	0.19	0.020<	0.37+	0.187+		10.2	0.078	0.052		379	-4.47
3319DC00033	RY04	RY4	19910305	0.00	0.08<	0.066	0.013<	0.32	0.020<	0.38+	0.437+		9.7	0.070	0.026		433	-12.66
3319DC00036	RY07	RY7	19900604	0.00	0.08<	0.033	0.072	0.54	0.027	0.58+	0.057+	0.00	7.7	0.338	0.243	19.2	762	-3.31
3319DC00037	RY08	RY08	19900604	0.32	0.08<	0.019	0.371	1.51	0.020<	0.29+	0.040	0.00	10.4	0.525	0.132	14.0	1573	-0.93
3319DC00039	RY10	RY10	19900604	0.07	0.08<	0.098	0.018	0.31	0.024	3.81^	0.872+	0.00	12.7	0.344	0.103		489	5.35
3319DC00039	RY10	RY10	19900907	0.07	0.08<	0.061	0.013<	0.18	0.020<	1.42^	1.446^		11.1	0.068	0.064		665	-0.39
3319DC00039	RY10	RY10	19901206	0.00	0.08<	0.043	0.073	0.53	0.020<	1.36^	0.974+		8.3	0.343	0.075		770	1.78
3319DC00039	RY10	RY10	19910305	0.00	0.08<	0.094	0.118	1.20	0.020<	2.99^	1.972^		14.0	0.676	0.149		1413	-1.51
3319DC00040	RY11	RY11	19900907	0.28	0.08<	0.125	0.013<	0.75	0.020<	1.65^	3.282^		11.8	0.544	0.098		984	-3.33
3319DC00040	RY11	RY11	19910305	0.00	0.08<	0.076	0.089	0.71	0.020<	2.76^	1.361^		12.1	0.511	0.060		1001	-0.29
3319DC00041	RY12	RY12	19900604	0.31	0.19+	0.052	0.170	1.21	0.000	2.59^	0.369+		10.0	0.646	0.211	15.8	1454	-5.03
3319DC00041	RY12	RY12	19900907	0.33	0.08<	0.028	0.089	1.07	0.020<	0.13+	0.025<		16.8	0.803	0.490		1186	-0.61
3319DC00041	RY12	RY12	19901206	0.00	0.08<	0.028	0.212	0.98	0.020<	0.76+	0.321+		10.6	0.542	0.368		1496	2.32
3319DC00041	RY12	RY12	19910305	0.00	0.08<	0.048	0.265	1.30	0.020<	1.58^	0.441+		11.4	0.676	0.074		1632	-0.25
3319DC00042	RY13	RY13	19900604	0.37	0.27+	0.052	1.700+	1.21	0.020<	0.73+	0.033		4.2	0.646	0.211	10.0	1255	-0.31
3319DC00042	RY13	RY13	19900907	0.00	0.08<	0.017	0.130<	0.00	0.020<	1.15^	0.236+		10.5	0.188	0.023		1350	-0.54
3319DC00042	RY13	RY13	19901206	0.00	0.08<	0.038	0.157	0.79	0.020<	0.27+	0.184+		10.7	0.543	0.269		1309	0.63
3319DC00042	RY13	RY13	19910305	0.00	0.08<	0.044	0.197	1.16	0.020<	0.41+	0.158+		10.8	0.606	0.170		1471	-0.24
3319DC00101	H4M18		19871005										3.7			16.0	4003	1.01
3319DC00101	H4M18		19871012										4.6			15.0	3594	-1.30
3319DC00101	H4M18		19871019										3.6			17.0	1170	1.17
3319DC00101	H4M18		19871026										4.6			15.0	2947	-0.27
3319DC00101	H4M18		19871102										5.5			0.0	2813	0.04
3319DC00101	H4M18		19871109										5.3			0.0	2362	-0.04

Site id	# on map	Sample #	Date	NO2-N mg/L	Al mg/L	Ba mg/L	B mg/L	Br mg/L	Cu mg/L	Fe mg/L	Mn mg/L	PO4 mg/L	Si mg/L	Sr mg/L	Zn mg/L	Temp. C	TDS () mg/L	Ion-ba %
3319DC00101	H4M18		19871116										5.2			21.0	2851	0.57
3319DC00101	H4M18		19871123										5.7			21.0	2417	2.24
3319DC00101	H4M18		19871130										4.1			20.6	2034	-0.78
3319DC00101	H4M18		19871207										5.0			20.0	2613	-1.13
3319DC00101	H4M18		19871214										5.6			19.0	2739	-1.25
3319DC00101	H4M18		19871221										6.2			26.0+	2480	-1.23
3319DC00101	H4M18		19871228										7.4			19.0	2188	0.71
3319DC00101	H4M18		19880104										6.3			25.0	2282	1.37
3319DC00101	H4M18		19880111										5.7			22.0	2456	1.26
3319DC00101	H4M18		19880118										4.1			27.0+	1249	-1.87
3319DC00101	H4M18		19880125										7.3			22.0	2374	0.87
3319DC00101	H4M18		19880201										5.7			27.0+	2011	0.41
3319DC00101	H4M18		19880208										6.5			16.0	2508	0.10
3319DC00101	H4M18		19880215										7.0			26.0+	2052	1.53
3319DC00101	H4M18		19880222										8.8			24.0	2786	-0.76
3319DC00101	H4M18		19880229										7.7			20.0	2391	1.06
3319DC00101	H4M18		19880307										8.6			18.0	3008	-2.52
3319DC00101	H4M18		19880314										8.4			24.0	4497	0.12
3319DC00101	H4M18		19880321										8.0			20.0	3927	0.73
3319DC00101	H4M18		19880328										3.5			23.0	1005	1.73
3319DC00101	H4M18		19880404										11.0			18.0	3327	2.25
3319DC00101	H4M18		19880411										7.0			17.0	3092	0.49
3319DC00101	H4M18		19880418										7.2			17.6	3258	1.41
3319DC00101	H4M18		19880425										2.5			13.8	589	3.16
3319DC00101	H4M18		19880502										3.0			20.0	572	2.45
3319DC00101	H4M18		19880509										6.0			15.0	2760	0.94
3319DC00101	H4M18		19880516										6.7			16.2	3456	-1.23
3319DC00101	H4M18		19880523										1.8			14.0	230	0.27
3319DC00101	H4M18		19880530										5.9			11.6	2702	1.08
3319DC00101	H4M18		19880606										1.7			12.0	296	2.83
3319DC00101	H4M18		19880613										2.4			13.0	465	2.58
3319DC00101	H4M18		19880620										5.4			12.0	2242	0.03
3319DC00101	H4M18		19880627										3.4			9.6	565	2.51
3319DC00101	H4M18		19880704										3.3			12.0	836	-1.75
3319DC00101	H4M18		19880711										2.6			8.0	936	-1.66
3319DC00101	H4M18		19880718										2.8			11.6	764	-2.61
3319DC00101	H4M18		19880725										6.1			8.6	3771	0.23
3319DC00101	H4M18		19880801										6.3			9.6	3637	-1.34
3319DC00101	H4M18		19880808										6.4			12.0	3467	-1.70
3319DC00101	H4M18		19880815										5.4			14.0	3733	-1.52
3319DC00101	H4M18		19880822										6.1			10.4	3782	-2.19
3319DC00101	H4M18		19880829										7.8			14.5	5413	-1.52
3319DC00101	H4M18		19880905										2.5			13.4	701	-0.52
3319DC00101	H4M18		19880912										4.9			11.4	4653	-1.22
3319DC00101	H4M18		19880919										3.7			14.0	3427	-1.32
3319DC00101	H4M18		19880926										3.6			14.8	3931	0.19
3319DC00101	H4M18		19881003										3.9			15.0	3458	-0.12
3319DC00101	H4M18		19881010										4.7			15.5	3027	-0.87

Site id	# on map	Sample #	Date	NO2-N mg/L	Al mg/L	Ba mg/L	B mg/L	Br mg/L	Cu mg/L	Fe mg/L	Mn mg/L	PO4 mg/L	Si mg/L	Sr mg/L	Zn mg/L	Temp. C	TDS () mg/L	Ion-ba %
3319DC00101	H4M18		19881017										3.8			15.6	2931	-0.38
3319DC00101	H4M18		19881024										4.1			17.0	2721	-0.74
3319DC00101	H4M18		19881025			0.087							3.7	1.811			2683	0.17
3319DC00101	H4M18		19881031										4.6			16.0	2593	-0.50
3319DC00101	H4M18		19881107										4.6			15.0	2453	-0.67
3319DC00101	H4M18		19881114										5.0			18.5	1999	0.14
3319DC00101	H4M18		19881121										4.2			22.0	2223	-0.14
3319DC00101	H4M18		19881128										3.9			22.0	2434	-0.80
3319DC00101	H4M18		19881205										9.0			15.0	3127	0.11
3319DC00101	H4M18		19881212										6.4			15.5	3427	0.48
3319DC00101	H4M18		19881219										4.6			20.0	2662	-0.41
3319DC00101	H4M18		19881226										8.3			22.0	3130	1.33
3319DC00101	H4M18		19890102										6.5			20.5	3203	0.11
3319DC00101	H4M18		19890109										7.1			20.0	3246	0.91
3319DC00101	H4M18		19890116										9.4		26.0+	3408	0.81	
3319DC00101	H4M18		19890123										9.8			19.0	4399	0.45
3319DC00101	H4M18		19890130										9.0			25.0	3617	0.80
3319DC00101	H4M18		19890206										9.7			24.0	3594	0.12
3319DC00101	H4M18		19890213										8.2			20.5	2893	1.62
3319DC00101	H4M18		19890220										6.2			22.0	2829	0.68
3319DC00101	H4M18		19890227										8.8			22.0	3474	0.03
3319DC00101	H4M18		19890306										7.6			23.0	3299	-0.46
3319DC00101	H4M18		19890313										6.5			18.5	3888	-1.61
3319DC00101	H4M18		19890320										8.0			20.0	3443	0.61
3319DC00101	H4M18		19890327										8.8			21.6	3254	-1.48
3319DC00101	H4M18		19890403										8.6			17.6	3495	-0.91
3319DC00101	H4M18		19890410										7.6			19.0	3066	0.24
3319DC00101	H4M18		19890417										7.7			16.2	3299	0.53
3319DC00101	H4M18		19890424										3.2			17.4	764	-2.34
3319DC00101	H4M18		19890426			0.107						29.00	7.7	1.854		3016	-0.67	
3319DC00101	H4M18		19890501										3.0			16.6	479	-2.91
3319DC00101	H4M18		19890508										2.5			17.0	462	-2.15
3319DC00101	H4M18		19890515										2.0			11.8	349	-0.88
3319DC00101	H4M18		19890522										5.6			15.0	2250	-1.71
3319DC00101	H4M18		19890529										6.0			10.0	2437	-1.25
3319DC00101	H4M18		19890605										7.6			13.5	5215	-0.32
3319DC00101	H4M18		19890612										8.6			13.6	4765	-0.84
3319DC00101	H4M18		19890619										6.2			13.0	3260	0.37
3319DC00101	H4M18		19890626										6.8			11.7	3902	-1.11
3319DC00101	H4M18		19890703										6.9			12.0	5022	-0.12
3319DC00101	H4M18		19890710										2.9			10.9	967	-0.44
3319DC00101	H4M18		19890717										2.4			12.0	534	-1.73
3319DC00101	H4M18		19890724										5.4			9.9	4698	-1.36
3319DC00101	H4M18		19890731										5.6			11.8	5829	-0.76
3319DC00101	H4M18		19890807										3.7			13.0	2537	-1.49
3319DC00101	H4M18		19890814										5.5			13.3	5867	0.08
3319DC00101	H4M18		19890821										2.5			13.3	4750	-2.39
3319DC00101	H4M18		19890828										2.2			13.0	2649	-1.32

Site id	# on map	Sample #	Date	NO2-N mg/L	Al mg/L	Ba mg/L	B mg/L	Br mg/L	Cu mg/L	Fe mg/L	Mn mg/L	PO4 mg/L	Si mg/L	Sr mg/L	Zn mg/L	Temp. C	TDS () mg/L	Ion-ba %
3319DC00101	H4M18		19890904										2.2			11.8	1068	-1.23
3319DC00101	H4M18		19890911										1.9			15.0	1179	-0.58
3319DC00101	H4M18		19890918										1.7			14.1	1762	-0.82
3319DC00101	H4M18		19890925										2.1			14.6	3055	-1.34
3319DC00101	H4M18	H4M18	19900601	0.39	0.08<	0.090	0.749+	4.96	0.021	0.15+	0.209+	0.00	9.4	1.997	0.258		4162	-3.62
3319DC00101	H4M18	H4M18	19900621	0.00	0.08<	0.027	0.092	1.05	0.020<	0.21+	0.025<	0.00	3.8	0.397	0.036		905	-0.81
3319DC00101	H4M18	H4M18	19900723	0.00	0.08<	0.011	0.044	0.15	0.020<	0.12+	0.025<		2.6	0.149	0.008		918	0.14
3319DC00101	H4M18	H4M18	19900905	0.15	0.08<	0.040	0.036	1.00	0.020<	0.17+	0.025<		2.4	0.584	0.020		3268	-1.03
3319DC00101	H4M18	H4M18	19900925	0.00	0.08<	0.060	0.648+	2.84	0.020<	0.02<	0.025<		1.1	1.363	0.029		3442	-3.27
3319DC00101	H4M18	POESJENE	19901025	0.00	0.08<	0.068	0.556+	3.72	0.020<	0.24+	0.025<		0.9	1.555	0.005<		3751	-0.90
3319DC00101	H4M18	POESJENE	19901127	0.00	0.08<	0.072	0.519+	3.82	0.020<	0.38+	0.025<		0.6	1.673	0.071	24.2	3058	-2.98
3319DC00101	H4M18	POESJENE	19901205	0.00	0.08<	0.081	0.534+	3.78	0.020<	0.89+	0.081+		5.2	1.724	0.121		2954	5.10
3319DC00101	H4M18	POESJENE	19901218	0.00	0.08<	0.078	0.761+	4.68	0.020<	0.02<	0.025<		5.7	2.020	0.034	22.8	3816	0.37
3319DC00101	H4M18	POESJENE	19910213	0.00	0.08<	0.078	0.486	2.94	0.020<	0.02<	0.205+		7.2	1.679	0.092		2631	1.85
3319DC00101	H4M18	POESJENE	19910302	0.00	0.08<	0.098	0.778+	4.31	0.020<	0.16+	0.088+		8.0	2.194	0.026		3985	0.53
3319DC00101	H4M18	POESJENE	19910319	0.00				5.12				0.00					4173	0.19
3319DC00101	H4M18	POESJENE	19910423	0.00				4.20				0.00					3297	-1.12
3319DC00102	H4M17		19871005										1.6			18.0	106	1.20
3319DC00102	H4M17		19871012										2.2			18.0	157	-3.04
3319DC00102	H4M17		19871019										4.0			19.5	170	-3.82
3319DC00102	H4M17		19871026										3.8			18.0	216	-3.73
3319DC00102	H4M17		19871102										3.2			0.0	253	0.21
3319DC00102	H4M17		19871109										3.8			0.0	130	1.68
3319DC00102	H4M17		19871116										3.1			20.0	147	-0.21
3319DC00102	H4M17		19871123										5.9			22.0	138	3.43
3319DC00102	H4M17		19871130										5.7			22.0	150	0.00
3319DC00102	H4M17		19871207										4.8			15.0	130	0.00
3319DC00102	H4M17		19871214										4.2			19.0	63	-2.70
3319DC00102	H4M17		19871221										2.7			26.0+	105	0.30
3319DC00102	H4M17		19871228										3.6			19.0	111	2.52
3319DC00102	H4M17		19880104										4.8			24.0	104	3.05
3319DC00102	H4M17		19880111										5.6			26.0+	96	5.61
3319DC00102	H4M17		19880118										4.5			26.0+	82	7.17
3319DC00102	H4M17		19880125										5.5			18.0	85	5.97
3319DC00102	H4M17		19880201										7.4			26.0+	85	7.58
3319DC00102	H4M17		19880208										9.3			18.0	94	1.07
3319DC00102	H4M17		19880215										4.1			26.0+	74	-1.75
3319DC00102	H4M17		19880222										3.7			26.0+	80	2.38
3319DC00102	H4M17		19880229										5.8			24.0	90	-0.36
3319DC00102	H4M17		19880307										9.6			22.0	99	-3.16
3319DC00102	H4M17		19880314										7.6			24.0	115	0.28
3319DC00102	H4M17		19880321										7.1			19.0	119	-1.09
3319DC00102	H4M17		19880329										8.7			22.0	109	1.50
3319DC00102	H4M17		19880404										6.7			20.0	113	2.02
3319DC00102	H4M17		19880411										8.2			18.0	101	1.32
3319DC00102	H4M17		19880418										6.5			19.3	104	6.42
3319DC00102	H4M17		19880425										4.6			13.6	66	6.80
3319DC00102	H4M17		19880502										6.3			19.0	111	2.01

181

Site id	# on map	Sample #	Date	NO2-N mg/L	Al mg/L	Ba mg/L	B mg/L	Br mg/L	Cu mg/L	Fe mg/L	Mn mg/L	PO4 mg/L	Si mg/L	Sr mg/L	Zn mg/L	Temp. C	TDS () mg/L	Ion-ba %
3319DC00102	H4M17		19880509										6.1			17.0	158	2.18
3319DC00102	H4M17		19880516										7.1			16.6	213	-5.04
3319DC00102	H4M17		19880523										6.5			14.0	58	0.61
3319DC00102	H4M17		19880530										6.2			13.0	56	-9.33
3319DC00102	H4M17		19880606										4.5			13.0	41	1.69
3319DC00102	H4M17		19880613										4.5			12.5	83	0.80
3319DC00102	H4M17		19880620										3.7			11.0	95	0.35
3319DC00102	H4M17		19880627										2.9			10.6	117	1.63
3319DC00102	H4M17		19880704										1.8			12.0	171	0.92
3319DC00102	H4M17		19880711										2.1			9.2	40	0.00
3319DC00102	H4M17		19880718										1.8			11.6	97	3.21
3319DC00102	H4M17		19880725										2.8			10.8	62	5.64
3319DC00102	H4M17		19880801										2.8			12.6	141	0.68
3319DC00102	H4M17		19880808										1.4			12.5	208	-1.84
3319DC00102	H4M17		19880815										1.9			14.0	124	0.51
3319DC00102	H4M17		19880822										4.1			11.6	191	-0.83
3319DC00102	H4M17		19880829										1.3			14.0	224	-2.54
3319DC00102	H4M17		19880905										1.3			13.4	80	-1.61
3319DC00102	H4M17		19880912										1.4			11.6	34	6.42
3319DC00102	H4M17		19880919										1.9			15.0	45	4.83
3319DC00102	H4M17		19880926										2.3			16.5	95	-1.34
3319DC00102	H4M17		19881003										2.9			17.0	80	-5.69
3319DC00102	H4M17		19881010										1.5			16.6	121	-4.71
3319DC00102	H4M17		19881017										2.2			18.6	162	-3.50
3319DC00102	H4M17		19881024										2.7			19.0	214	-1.18
3319DC00102	H4M17		19881025			0.031							1.2	0.132		19.0	192	4.31
3319DC00102	H4M17		19881031										3.4			19.0	189	-2.02
3319DC00102	H4M17		19881107										3.7			22.0	111	-3.17
3319DC00102	H4M17		19881114										4.7			23.5	172	-3.35
3319DC00102	H4M17		19881121										5.5			25.0	150	-1.50
3319DC00102	H4M17		19881128										5.6			25.0	113	4.97
3319DC00102	H4M17		19881205										4.6			20.0	110	5.38
3319DC00102	H4M17		19881212										4.3			21.4	113	-2.82
3319DC00102	H4M17		19881219										5.4			24.4	100	6.29
3319DC00102	H4M17		19881226										7.7			20.0	105	-0.31
3319DC00102	H4M17		19890102										7.3			25.0	94	-4.44
3319DC00102	H4M17		19890109										7.2			24.0	82	0.81
3319DC00102	H4M17		19890116										9.7			25.0	87	-1.20
3319DC00102	H4M17		19890123										7.1			24.0	71	3.23
3319DC00102	H4M17		19890130										6.5			25.0	73	3.57
3319DC00102	H4M17		19890206										8.1			26.0+	79	-1.32
3319DC00102	H4M17		19890213										9.4			24.2	86	-5.08
3319DC00102	H4M17		19890220										6.9			25.0	88	-0.39
3319DC00102	H4M17		19890227										7.9			24.0	83	-4.68
3319DC00102	H4M17		19890306										7.3			22.5	83	-7.30
3319DC00102	H4M17		19890313										4.9			21.7	92	0.70
3319DC00102	H4M17		19890320										4.3			21.0	93	-1.38
3319DC00102	H4M17		19890327										4.6			22.4	114	1.39

Site id	# on map	Sample #	Date	NO2-N mg/L	Al mg/L	Ba mg/L	B mg/L	Br mg/L	Cu mg/L	Fe mg/L	Mn mg/L	PO4 mg/L	Si mg/L	Sr mg/L	Zn mg/L	Temp. C	TDS () mg/L	Ion-ba t
3319DC00102	H4M17		19890403										5.7			17.6	51	8.61
3319DC00102	H4M17		19890410										6.1			22.0	126	4.50
3319DC00102	H4M17		19890417										5.0			18.5	133	-3.16
3319DC00102	H4M17		19890424										5.6			17.5	125	0.00
3319DC00102	H4M17		19890426			0.022						0.04		0.349			170	1.41
3319DC00102	H4M17		19890501										5.4			17.6	236	-2.44
3319DC00102	H4M17		19890508										6.7			17.2	284	-2.39
3319DC00102	H4M17		19890515										7.4			12.9	63	1.12
3319DC00102	H4M17		19890522										7.3			14.8	98	2.07
3319DC00102	H4M17		19890529										4.8			13.8	151	1.27
3319DC00102	H4M17		19890605										5.5			11.5	70	4.35
3319DC00102	H4M17		19890612										4.3			12.0	134	1.44
3319DC00102	H4M17		19890619										3.7			12.6	206	1.23
3319DC00102	H4M17		19890626										4.0			11.7	158	2.45
3319DC00102	H4M17		19890703										2.2			11.8	99	
3319DC00102	H4M17		19890710										1.5			11.0	100	-1.61
3319DC00102	H4M17		19890717										1.4			12.2	123	0.52
3319DC00102	H4M17		19890724										2.0			10.5	109	-3.28
3319DC00102	H4M17		19890731										3.0			10.9	117	-3.68
3319DC00102	H4M17		19890807										1.7			13.1	108	-3.28
3319DC00102	H4M17		19890814										1.9			13.5	130	-0.99
3319DC00102	H4M17		19890821										1.8			13.7	73	1.30
3319DC00102	H4M17		19890828										1.9			12.1	52	4.94
3319DC00102	H4M17		19890904										1.8			11.7	81	-0.79
3319DC00102	H4M17	H4M17	19900601	0.13	0.08<	0.019	0.013<	0.15	0.033	0.38+	0.025<	0.00	2.5	0.089	0.272		183	2.25
3319DC00102	H4M17	H4M17	19900621	0.00	0.08<	0.017	0.013<	0.18	0.020<	0.32+	0.025<	0.00	2.9	0.114	0.036		226	6.35
3319DC00102	H4M17	H4M17	19900723	0.00	0.08<	0.052	0.257	0.95	0.020<	0.27+	0.025<		2.6	0.909	0.014		167	5.12
3319DC00102	H4M17	H4M17	19900900	0.00	0.08<	0.015	0.044	0.16	0.020<	0.21+	0.056+		1.5	0.155	0.033		251	8.85
3319DC00102	H4M17	LE CHASS	19900905	0.79	0.08<	0.046	0.518+	3.73	0.020<	0.37+	0.025<		1.3	1.688	0.009		179	0.88
3319DC00102	H4M17	H4M17	19901025	0.00	0.08<	0.015	0.034	0.00	0.021	0.20+	0.025<		3.8	0.109	0.005<		222	-2.01
3319DC00102	H4M17	LE CHASS	19901127	0.00	0.08<	0.012	0.056	0.18	0.020<	0.38+	0.025<		0.6	0.083	0.071	24.2	172	-0.18
3319DC00102	H4M17	LE CHASS	19901205	0.00	0.08<	0.015	0.042	0.00	0.020<	0.43+	0.029	0.00	0.3	0.083	0.088		163	0.00
3319DC00102	H4M17	LE CHASS	19901218	0.00	0.14	0.012	0.044	0.18	0.020<	0.32+	0.025<		0.4	0.072	0.048	22.7	134	2.34
3319DC00102	H4M17	LE CHASS	19910122	0.00	0.08	0.009	0.044	0.12	0.029	0.12+	0.025<		0.2	0.051	0.060	26.0+	101	5.88
3319DC00102	H4M17	LE CHASS	19910213	0.00	0.12	0.014	0.046	0.17	0.036	0.82+	0.054+		0.4	0.066	0.051		128	0.73
3319DC00102	H4M17	LE CHASS	19910302	0.00	0.08	0.015	0.025	0.24	0.020<	0.38+	0.025<		0.5	0.061	0.015	26.1+	160	-7.13
3319DC00102	H4M17	LE CHASS	19910319	0.00				0.00				0.00					142	16.81
3319DC00102	H4M17	LE CHASS	19910423	0.00				0.00				0.00					191	28.21
3319DC00104	B7		19881025			0.088							7.2	0.029			76	3.20
3319DC00104	B7		19890426			0.004<						0.02	17.6	0.282			285	-3.10
3319DC00107	AB	AB	19900607	0.00	0.00	0.091	0.183	4.79	0.000	0.00	0.793+	0.00	9.7	3.172	0.027		3579	-2.36
3319DC00107	AB	AB	19900905	0.00	0.08<	0.011	0.027	0.07	0.020<	0.02	0.521+		10.2	0.133	0.021		3745	0.73
3319DC00107	AB	AB	19901205	0.00	0.08<	0.093	0.185	4.93	0.020<	0.42+	1.057+		9.8	3.207	0.087		3650	-0.41
3319DC00107	AB	AB	19910302	0.00	0.08<	0.083	0.215	4.77	0.020<	0.10	0.025<		9.8	3.266	0.016	22.0	3737	0.35
3319DC00108	U	U	19900602	0.00	0.08<	0.079	0.013<	0.00	0.020<	0.27+	0.025<	0.00	9.4	0.039	0.574		109	4.70
3319DC00108	U	U	19900905	0.00	0.08<	0.058	0.013<	0.05	0.020<	0.02<	0.025<		10.6	0.033	0.050	24.0	116	1.49
3319DC00108	U	U	19901205	0.00	0.08<	0.082	0.013<	0.04	0.020<	0.25+	0.025<		10.3	0.044	0.109		119	5.75
3319DC00108	U	U	19910227	0.00	0.08<	0.074	0.013<	0.09	0.022	0.25+	0.025<		9.6	0.035	0.090	27.0+	108	-5.30

Site id	# on map	Sample #	Date	NO2-N mg/L	Al mg/L	Ba mg/L	B mg/L	Br mg/L	Cu mg/L	Fe mg/L	Mn mg/L	PO4 mg/L	Si mg/L	Sr mg/L	Zn mg/L	Temp. C	TDS () mg/L	Ion-ba %
3319DC00109	T	T	19900602	0.00	0.08<	0.098	0.013<	0.00	0.020<	0.31+	0.239+	0.00	14.5	0.135	0.471		204	2.17
3319DC00110	Y	Y	19900604	0.00	0.08<	0.028	0.013<	0.34	0.020<	0.08	0.705+	0.00	27.5	0.065	0.113		305	-0.44
3319DC00110	Y	Y	19900907	0.32	0.08<	0.009	0.013<	1.01	0.020<	1.70^	0.726+		28.1	0.367	0.026		282	0.50
3319DC00110	Y	Y	19901206	0.00	0.08<	0.023	0.013<	0.18	0.020<	0.29+	0.740+		29.1	0.065	0.096		255	1.69
3319DC00110	Y	Y	19910305	0.00	0.08<	0.023	0.014	0.26	0.020<	0.29+	0.706+		27.6	0.065	0.054		306	-0.23
3319DC00111	X	X	19900604	0.00	0.08<	0.077	0.065	0.30	0.020<	0.04	0.025<	0.00	12.1	0.407	0.038		687	-0.81
3319DC00111	X	X	19900907	0.12	0.08<	0.056	0.013<	0.38	0.020<	0.12+	0.025<		19.6	0.098	0.020		763	1.70
3319DC00111	X	X	19901206	0.00	0.08<	0.055	0.045	0.21	0.020<	0.32+	0.025<		16.7	0.552	0.038		526	0.55
3319DC00111	X	X	19910305	0.00	0.08<	0.077	0.140	1.19	0.020<	0.17+	1.687^		13.9	1.059	0.105		1505	-3.08
3319DC00112	DN06A	DN6A	19900601	0.00	0.08<	0.060	0.013<	0.12	0.020<	0.04	0.025<		7.1	0.028	0.225	26.3+	100	0.98
3319DC00113	LEC01	LEC01	19900621	0.00	0.08<	0.016	0.013<	0.03	0.020<	0.29+	0.025<		3.1	0.082	0.036		146	9.29
3319DC00113	LEC01	LEC01	19900723	0.01	0.05<	0.012	0.024	0.02	0.020<	0.25+	0.025<		4.6	0.103	0.114		139	5.99
3319DC00113	LEC01	LEC01	19900900	0.00	0.08<	0.013	0.013<	0.00	0.020<	0.28+	0.025<		1.8	0.650	0.310		121	5.15
3319DC00113	LEC01	LEC01	19901025	0.00	0.14	0.014	0.013<	0.00	0.020<	0.40+	0.025<		0.6	0.047	0.005		79	24.36
3319DC00113	LEC01	LEC01	19901127	0.00	0.15	0.011	0.013	0.00	0.020<	0.24+	0.025<		0.9	0.032	0.044		67	13.89
3319DC00113	LEC01	LEC01	19901218	0.00	0.10	0.011	0.013<	0.00	0.020<	0.21+	0.025<		0.4	0.039	0.057		66	9.68
3319DC00113	LEC01	LEC01	19910122	0.00	0.09	0.010	0.028	0.06	0.047	0.11+	0.025<		0.4	0.036	0.064		68	17.06
3319DC00113	LEC01	LEC01	19910213	0.00	0.10	0.040	0.00	0.00	0.010	0.13+	0.025<		0.3	0.027	0.082		96	-4.32
3319DC00113	LEC01	LEC01	19910319	0.00			0.00					0.70					144	-26.25
3319DC00113	LEC01	LEC01	19910423	0.00			0.00					0.00					105	12.54
3319DC00114	LEC02	LEC02	19900621	0.00	0.08<	0.018	0.013<	0.17	0.020<	0.24+	0.025<		2.5	0.110	0.037		192	11.18
3319DC00115	O	O	19900601	0.00	0.08<	0.016	0.013<	0.00	0.303	0.05	0.025<		2.7	0.024	0.441		70	16.88
3319DC00116	RY14	RY14	19900900	0.00	0.08<	0.046	0.164	1.07	0.020<	0.26+	0.627+		13.2	0.567	0.155		1436	-1.34
3319DC00116	RY14	RY14	19900907	0.35	0.08<	0.048	0.361	1.45	0.020<	0.37+	1.844^		11.8	0.441	0.022		2141	0.99
3319DC00118	DN07B	DN7B	19900905	0.31	0.08<	0.009	0.116	1.02	0.020<	0.36+	0.137+		16.6	0.876	0.044	22.0	1502	0.55
3319DD00001	G33570	G33570	19900608	0.00	0.08<	0.018	1.759+	6.01	0.020<	0.07	0.078+	0.00	0.7	0.239	0.086		4209	-1.03
3319DD00001	G33570	G33570	19900620	0.00	0.08<	0.024	1.767+	8.80	0.020<	0.43+	0.093+	0.00	0.6	0.229	0.040		4170	0.24
3319DD00001	G33570	G33570	19900727	0.70	0.08<	0.121	0.539+	1.73	0.020<	0.31+	0.025<		2.2	0.841	0.051		4450	-0.51
3319DD00001	G33570	G33570	19901200	0.00	0.08<	0.284	0.641+	0.29	0.020<	0.02<	0.052+		7.6	0.132	0.024		866	-8.04
3319DD00001	G33570	G33570	19910131	0.00	0.08<	0.018	1.486+	8.45	0.020<	0.36+	0.025<		0.6	0.171	0.035		4170	2.46
3319DD00001	G33570	G33570	19910305	0.00			5.66					0.00					4132	-1.15
3319DD00001	G33570	G33570	19910426	0.00			5.44					2.53					4069	-0.70
3319DD00003	G33571A	G33571A	19900620	0.00	0.00		2.289^	29.50	0.000	0.02<	4.842^	0.00	6.3	10.518	0.062		15125^	-0.98
3319DD00003	G33571A	G33571A	19900727	3.04	0.08<	0.024	5.946^	21.66	0.020<	0.02<	4.671^		9.4	9.212	0.005<		15939^	-1.28
3319DD00003	G33571A	G33571A	19901000	0.00	0.08<	0.152	1.785+	29.60	0.174	2.27^	4.376^		4.2	9.601	0.005<		15499^	0.57
3319DD00003	G33571A	G33571A	19901200	0.00	0.08<	0.145	1.952+		0.020<	0.02<	4.154^		5.1	10.634	0.062		16119^	-3.17
3319DD00003	G33571A	G33571A	19910131	0.00	0.08<	0.192	2.040^	31.90	0.144	0.02<	4.416^		4.3	9.816	0.144		15403^	0.71
3319DD00004	G33572	G33572	19900620	0.00	0.08<	0.017	0.894+	2.30	0.020<	0.08	0.030	0.00	1.1	0.173	0.026		1665	-0.40
3319DD00004	G33572	G33572	19900727	0.53	0.08<	0.042	0.452	2.90	0.020<	0.49+	0.025<		2.3	1.152	0.046		1449	17.15
3319DD00004	G33572	G33572	19900900	0.00	0.08<	0.024	0.734+	2.77	0.020<	0.28+	0.025<		6.7	0.193	0.043		1641	-2.52
3319DD00004	G33572	G33572	19901000	0.00	0.08<	0.022	0.778+	2.50	0.020<	0.18+	0.053+		0.7	0.221	0.030		1810	-0.35
3319DD00004	G33572	G33572	19901200	0.00	0.13	0.025	0.747+	2.21	0.020<	0.51+	0.049		0.7	0.207	0.026		1582	2.28
3319DD00004	G33572	G33572	19910131	0.00	0.08<	0.024	0.764+	1.90	0.020<	0.15+	0.025<		0.5	0.202	0.025		1572	4.06
3319DD00004	G33572	G33572	19910305	0.00			5.03					0.00					3391	-2.12
3319DD00004	G33572	G33572	19910426	0.00			4.50					0.00					3436	-0.66
3319DD00005	G33573	G33573	19900620	0.00	0.08<	0.009	1.244+	7.40	0.020<	0.10	0.101+	0.00	1.4	0.321	0.036		3628	-0.42
3319DD00005	G33573	G33573	19900727	1.32	0.08<	0.023	1.166+	5.10	0.029	0.05	0.131+		2.3	1.386	0.041		3828	4.54
3319DD00005	G33573	G33573	19901200	0.00	0.08<	0.010	2.332^	17.50	0.020<	0.10	0.029		0.5<	0.152	0.105		10155^	-2.11

183

Site id	# on map	Sample #	Date	NO2-N mg/L	Al mg/L	Ba mg/L	B mg/L	Br mg/L	Cu mg/L	Fe mg/L	Mn mg/L	PO4 mg/L	Si mg/L	Sr mg/L	Zn mg/L	Temp. C	TDS () mg/L	Ion-ba %
3319DD00005	G33573	G33573	19910131	0.00	0.08<	0.015	1.073+	7.26	0.020<	0.39+	0.025<		0.8	0.326	0.068		3889	-2.14
3319DD00005	G33573	G33573	19910305	0.00				0.10				0.68					324	3.35
3319DD00005	G33573	G33573	19910426	0.00				0.35				0.00					326	-12.20
3319DD00006	G33574	G33574	19900620	0.00	0.08	0.024	1.526+	15.50	0.024	0.26+	0.204+	0.00	0.9	0.493	0.036		7767	-3.44
3319DD00007	G33575	G33575	19900620	0.00	0.08<	0.010	0.901+	5.30	0.020<	0.12+	0.069+	0.00	0.1	0.118	0.032		2943	-2.27
3319DD00007	G33575	G33575	19910305	0.00				2.24				0.00					1592	0.11
3319DD00007	G33575	G33575	19910426	0.00				2.48				0.00					1640	3.54
3319DD00008	G33576	G33576	19900620	0.00	0.08<	0.578+	0.457	7.30	0.020<	0.36+	0.197+	0.00	0.2	1.516	0.021		3676	-1.34
3319DD00008	G33576	G33576	19900727	1.73	0.08<	0.124	0.900+	8.70	0.041	1.37^	0.209+		0.8	4.012	0.021		3676	0.75
3319DD00008	G33576	G33576	19901200	0.00	0.08<	0.533+	0.376	6.19	0.020<	1.47^	0.236+		0.4	1.552	0.064		3511	3.90
3319DD00008	G33576	G33576	19910131	0.00	0.08<	0.555+	0.427	5.99	0.020<	0.34+	0.239+		0.3	1.529	0.054		3594	2.44
3319DD00008	G33576	G33576	19910305	0.00				3.45				0.00					2148	-0.94
3319DD00008	G33576	G33576	19910426	0.00				3.47				0.00					2170	1.67
3319DD00009	G33577	G33577	19900619	0.00	0.08<	0.035	1.006+	13.40	0.020<	0.15+	0.442+	0.00	0.1	0.435	0.051		8790	-0.93
3319DD00009	G33577	G33577	19900724	1.69	0.08<	0.005	2.739^	5.87	0.002<	0.19+	0.606+		0.8	0.538	0.005<		9035	-0.31
3319DD00009	G33577	G33577	19900900	0.00	0.12	0.030	0.824+	18.04	0.020<	0.29+	0.338+		0.1<	0.447	0.099		9082	-5.23
3319DD00009	G33577	G33577	19901000	0.00	0.08<	0.044	0.850+	15.12	0.020<	1.06^	0.142+		0.1<	0.621	0.556		9635	-5.81
3319DD00009	G33577	G33577	19901200	0.00	0.11	0.026	0.056	1.16	0.020<	0.60+	0.048		0.3	0.311	0.074		748	0.31
3319DD00009	G33577	G33577	19910131	1.63	0.02	0.027	0.073	0.79	0.020<	0.34+	0.064+		0.4	0.372	0.034		747	-0.23
3319DD00009	G33577	G33577	19910228	0.00				6.42				1.52					4502	-3.19
3319DD00009	G33577	G33577	19910425	0.00				6.21				0.00					4543	-2.41
3319DD00014	G33582	G33582	19900620	0.00	0.08<	0.058	1.764+	32.00	0.053	64.45^	3.344^		0.8	10.787	0.058		18826^	-1.64
3319DD00014	G33582	G33582	19900727	1.26	0.08<	0.061	1.066+	6.53	0.020<	68.73^	3.329^		0.1	9.482	0.006		19885^	-1.01
3319DD00014	G33582	G33582	19900900	0.00	0.08<	0.041	1.327+	36.41	0.020	35.96^	3.900^		0.5<	10.496	0.123		19042^	-3.62
3319DD00014	G33582	G33582	19901000	0.00	0.30+	0.109	1.316+	36.67	0.020<	14.77^	5.250^		0.2	11.249	0.072		19663^	-10.95
3319DD00014	G33582	G33582	19901200	0.00	0.08<	0.011	0.796+	1.25	0.020<	0.02<	0.025<		9.2	0.975	0.012		1572	3.09
3319DD00014	G33582	G33582	19910131	0.00	0.08<	0.080	1.315+	34.19	0.199	15.15^	4.823^		0.1<	10.603	0.159		18368^	-0.23
3319DD00014	G33582	G33582	19910305	0.00				16.93				2.94					10695^	9.30
3319DD00014	G33582	G33582	19910426	0.00				17.61				4.46					9521	-6.30
3319DD00015	G33583	G33583	19900620	0.00	0.08<	0.005	2.658^	16.90	0.020<	0.91+	0.379+	0.00	0.1	0.466	0.035		9795	-3.30
3319DD00015	G33583	G33583	19900727	6.46+	0.08	0.002<	1.843+	34.26	0.063	0.35+	0.092+		0.1	14.365	0.105		10124^	2.50
3319DD00015	G33583	G33583	19901200	0.00	0.08	0.026	1.483+	21.16	0.020<	4.22^	1.748^		0.1<	1.973	0.159		12844^	-2.90
3319DD00015	G33583	G33583	19910131	0.00	0.08<	0.040	2.191^	23.40	0.040	0.02<	0.025<		0.1<	0.160	0.214		10434^	-3.36
3319DD00015	G33583	G33583	19910305	0.00				9.95				2.18					7060	-3.84
3319DD00015	G33583	G33583	19910426	0.00				9.99				0.00					6826	-4.53
3319DD00016	G33584	G33584	19900620	0.00	0.08<	0.004	1.992+	10.00	0.020<	0.51+	0.078+	0.00	0.7	0.384	0.026		7168	0.18
3319DD00016	G33584	G33584	19900727	3.65	0.08<	0.002<	2.486^	14.08	0.107	0.10	0.025<		0.6	0.503	0.061		7302	-0.02
3319DD00016	G33584	G33584	19900900	0.00	0.20+	0.020<	1.651+	11.58	0.058	0.02<	0.025<		0.1<	0.288	0.048		7166	-4.56
3319DD00016	G33584	G33584	19901000	0.00	0.08<	0.013	1.661+	11.35	0.063	1.48^	0.025<		0.1<	0.315	0.005<		7702	-5.26
3319DD00016	G33584	G33584	19901200	0.00	0.08<	0.044	3.567^	3.44	0.020<	0.02<	0.025<		9.3	0.942	0.005<		4986	-0.83
3319DD00016	G33584	G33584	19910131	0.00	0.12	0.019	1.728+	12.55	0.020<	0.56+	0.025<		0.2	0.321	0.094		7683	-4.45
3319DD00016	G33584	G33584	19910305	0.00				6.31				0.00					3738	-5.87
3319DD00016	G33584	G33584	19910426	0.00				5.72				0.00					3792	-1.09
3319DD00020	G33588	G33588	19900619	0.00	0.08<	0.024	3.522^	16.88	0.020<	0.02<	0.036	0.00	7.7	3.659	0.036		12555^	-0.98
3319DD00020	G33588	G33588	19900724	0.65	0.08<	0.100	0.200	2.13	0.020<	0.02<	0.025<		11.3	2.780	0.040		12259^	1.53
3319DD00020	G33588	G33588	19901200	0.00	0.08<	0.031	2.952^	2.22	0.020<	0.02<	0.025<		7.6	2.889	0.066		6310	59.71
3319DD00020	G33588	G33588	19910131	0.00	0.08<	0.061	0.251	1.53	0.052	0.23+	0.025<		6.3	1.076	0.088		1732	-3.47
3319DD00020	G33588	G33588	19910228	0.00				6.31				3.31					5931	-1.56

Site id	# on map	Sample #	Date	NO2-N mg/L	Al mg/L	Ba mg/L	B mg/L	Br mg/L	Cu mg/L	Fe mg/L	Mn mg/L	PO4 mg/L	Si mg/L	Sr mg/L	Zn mg/L	Temp. C	TDS () mg/L	Ion-ba %
3319DD00020	G33588	G33588	19910425	0.00				5.66				5.44					5693	-3.32
3319DD00021	G33589	G33589	19900619	0.00	0.08<	0.138	1.134+	7.00	0.020<	0.02<	0.550+	0.00					4434	-0.10
3319DD00021	G33589	G33589	19900724	3.23	0.08<	0.012	1.078+	14.08	0.109	0.02<	1.000+		9.2	6.282	0.029		4791	4.85
3319DD00021	G33589	G33589	19901200	0.00	0.08<	0.045	0.040	1.28	0.020<	1.10^	0.380+		10.6	0.618	0.109		643	24.75
3319DD00021	G33589	G33589	19910131	0.00	0.08<	0.027	0.050	1.10	0.020<	0.33+	0.172+		0.8	0.457	0.027		761	1.12
3319DD00021	G33589	G33589	19910228	0.00				31.38				0.00					17667^	-6.98
3319DD00021	G33589	G33589	19910426	0.00				36.46				0.00					17712^	-6.54
3319DD00022	G33590	G33590	19900620	0.00	0.08<	0.032	0.228	0.90	0.020<	0.20+	0.032	0.00	0.7	0.157	0.034		674	-3.94
3319DD00022	G33590	G33590	19900727	1.29	0.13	0.016	1.218+	4.89	0.200<	0.64+	0.047		1.3	0.769	0.018		687	-0.73
3319DD00022	G33590	G33590	19900900	0.00	0.08<	0.018	0.265	0.99	0.020<	0.22+	0.025<		0.8	0.166	0.040		748	-0.67
3319DD00022	G33590	G33590	19901000	0.00	0.08<	0.020	0.269	0.81	0.020<	0.37+	0.045		1.8	0.170	0.010		744	0.34
3319DD00022	G33590	G33590	19901200	0.00	0.08<	0.061	1.087+	6.33	0.020<	0.88	0.029		6.5	1.269	0.067		4041	1.55
3319DD00022	G33590	G33590	19910131	0.00	0.08<	0.015	0.087	0.44	0.020<	0.30+	0.025<		0.4	0.125	0.037		281	7.09
3319DD00022	G33590	G33590	19910305	0.00				0.34				0.30					906	-10.68
3319DD00022	G33590	G33590	19910426	0.00				0.37				0.00					479	-9.37
3319DD00024	G33592	G33592	19900620	0.00	0.08<	0.014	0.280	0.00	0.020<	0.30+	0.229+	0.00	2.7	0.095	0.035		515	1.19
3319DD00024	G33592	G33592	19900727	0.06	0.08<	0.017	0.263	0.82	0.020<	0.49+	0.172+		4.9	0.181	0.049		557	8.12
3319DD00024	G33592	G33592	19901200	0.00	0.08<	0.061	1.087+	6.78	0.020<	0.43+	0.025<		1.0	1.269	0.144		3836	-1.14
3319DD00024	G33592	G33592	19910131	0.00	0.08<	0.081	0.560+	0.37	0.020<	1.15^	0.195+		8.2	0.131	0.043		769	-2.50
3319DD00024	G33592	G33592	19910305	0.00				1.67				1.50					1464	1.83
3319DD00024	G33592	G33592	19910426	0.00				1.81				1.04					1443	1.23
3319DD00029	BI02	BI2	19900606	0.00	0.08<	0.295	0.013<	0.00	0.020<	5.64^	1.374^	0.00	9.6	0.100	0.063	21.0	154	4.50
3319DD00029	BI02	BI2	19900904	0.22	0.08<	0.016	0.134	0.80	0.020<	2.32^	1.384^		10.5	0.600	0.092	22.0	153	4.00
3319DD00029	BI02	BI1	19901204	0.00	0.08<	0.299	0.013<	0.00	0.020<	2.64^	1.411^		10.1	0.102	0.057		157	0.75
3319DD00029	BI02	BI2	19910228	0.00	0.08<	0.297	0.013<	0.00	0.020<	3.89^	1.447^		9.6	0.094	0.022	24.0	151	-1.03
3319DD00033	GE01	GE1	19900605	0.00	0.08<	0.056	0.013<	0.08	0.020<	0.70+	0.766+	0.00	15.1	0.157	0.066		256	2.31
3319DD00033	GE01	GE1	19900906	0.10	0.08<	0.007	0.013<	0.49	0.032	0.78+	0.781+		15.7	0.863	0.948	22.5	281	-0.26
3319DD00033	GE01	GE1	19901207	0.00	0.08<	0.061	0.029	0.13	0.020<	0.79+	0.764+		16.3	0.169	0.128		302	-2.24
3319DD00033	GE01	GE1	19910226	0.00	0.08<	0.062	0.013<	0.00	0.022	0.85+	0.813+		16.1	0.165	0.043		303	-6.50
3319DD00035	KR01	KR1	19900608	0.00	0.08<	0.020	0.013<	0.21	0.023	21.57^	0.224+	0.00	4.0	0.027	0.450		180	6.83
3319DD00035	KR01	KR1	19900906	0.03	0.09	0.005	0.013<	0.38	0.020<	0.14+	0.025<		5.3	0.441	0.039		148	-4.44
3319DD00035	KR01	KR1	19901206	0.00	0.10	0.010	0.013<	0.00	0.020<	0.62+	0.025		1.8	0.025	4.699+		123	-20.11
3319DD00035	KR01	KR1	19910304	0.00	0.08<	0.017	0.013<	0.23	0.020<	6.78^	0.089+		4.5	0.062	12.453^	20.3	186	0.35
3319DD00042	MD07	MD7	19890426			0.004<						0.03	10.6	0.567			1137	1.76
3319DD00042	MD07	MD7	19900606	0.00	0.14	0.033	0.194	0.80	0.020<	0.51+	0.377+	0.00	10.9	0.465	0.046	20.4	1032	-2.73
3319DD00042	MD07	MD7	19900904	0.00	0.08<	0.259	0.019	0.00	0.020<	0.47+	0.344+		12.1	0.132	0.033	20.0	1060	0.26
3319DD00042	MD07	MD7	19901204	0.00	0.08<	0.029	0.200	0.71	0.020<	0.48+	0.344+		11.9	0.438	0.192	23.0	1052	0.06
3319DD00042	MD07	MD7	19910228	0.00	0.08<	0.027	0.167	0.73	0.020<	0.70+	0.280+		11.4	0.399	0.020	23.0	998	-2.67
3319DD00043	MD08	MD8	19900606	0.00	0.08<	0.008	0.015	1.37	0.027	0.12+	0.047	0.00	1.0	0.218	0.060	20.5	972	-3.18
3319DD00043	MD08	MD8	19900904	0.10	0.08<	0.234	0.146	0.64	0.020<	2.55^	1.107^		12.0	0.247	0.078	21.2	979	-0.67
3319DD00043	MD08	MD8	19901204	0.00	0.08<	0.013	0.083	0.72	0.020<	0.23+	0.130+		0.9	0.219	0.072		800	-4.49
3319DD00043	MD08	MD8	19910228	0.00	0.08<	0.039	0.138	1.60	0.020<	20.88^	2.844^		11.7	1.105	0.175	23.7	1902	-2.05
3319DD00045	DP04	DP4	19900609	0.00	0.12	0.023	0.013<	0.02	0.020<	0.04	0.480+	0.00	10.2	0.152	0.151		236	1.69
3319DD00045	DP04	DP4	19900906	0.00	0.08<	0.017	0.013<	0.00	0.020<	6.47^	0.526+		10.8	0.188	0.023		292	-11.87
3319DD00045	DP04	DP4	19901207	0.00	0.08<	0.009	0.013<	0.13	0.020<	0.05	0.200+		10.2	0.184	0.049	18.0	301	2.42
3319DD00045	DP04	DP4	19910304	0.00	0.08<	0.012	0.013<	0.10	0.020<	0.22+	0.224+		10.6	0.206	0.019	15.5	304	2.39
3319DD00047	DP06	DP6	19900608	0.02	0.08<	0.010	0.013<	0.30	0.020<	0.66+	0.345+	0.00	11.2	0.540	0.043		512	0.75
3319DD00047	DP06	DP6	19900907	0.03	0.08<	0.050	0.013<	0.11	0.020<	0.06	0.051+		1.5	0.213	0.118		402	-0.25

Site id	# on map	Sample #	Date	NO2-N mg/L	Al mg/L	Ba mg/L	B mg/L	Br mg/L	Cu mg/L	Fe mg/L	Mn mg/L	PO4 mg/L	Si mg/L	Sr mg/L	Zn mg/L	Temp- C	TDS () mg/L	Ion-ba %
3319DD00047	DP06	DP6	19901201	0.00	0.08<	0.016	0.013<	0.51	0.020<	1.36^	0.987+		11.3	0.601	0.077		627	0.43
3319DD00047	DP06	DP6	19910304	0.00	0.08<	0.007	0.013<	0.78	0.020<	2.86^	0.486+		5.3	0.541	0.187		601	0.60
3319DD00049	DP08	DP8	19900607	0.00	0.08<	0.034	0.036	1.08	0.020<	0.27+	0.042	0.00	10.5	1.517	2.097+		1085	-5.54
3319DD00050	DP09	DP9	19881026			0.085							8.6	0.594			709	3.41
3319DD00050	DP09	DP9	19890426			0.004<						0.03	10.3	0.704			784	-0.39
3319DD00050	DP09	DP9	19900607	0.20	0.08<	0.019	0.019	0.62	0.020<	2.40^	0.529+	49.11	10.7	0.957	0.609	19.3	1055	6.21
3319DD00050	DP09	DP9	19900907	0.00	0.08<	0.015	0.013<	0.00	0.265	0.22+	0.476+		11.2	0.067	0.325		773	-0.04
3319DD00050	DP09	DP9	19901206	0.00	0.08<	0.013	0.032	0.53	0.022	0.20+	0.370+		10.9	0.652	0.292		804	1.16
3319DD00050	DP09	DP9	19910304	0.00	0.08<	0.015	0.033	0.00	0.020<	0.55+	0.482+	184.67	11.1	0.851	0.247		1663	-13.48
3319DD00051	RE01	RE1	19881026			0.047							8.0	1.246			901	1.64
3319DD00051	RE01	RE1	19890426			0.021<						0.06	2.3	0.971			768	-3.05
3319DD00051	RE01	RE1	19900607	0.00	0.08<	0.022	0.067	0.75	0.021	0.65+	0.028	0.00	7.1	0.722	0.638	19.0	866	-3.77
3319DD00051	RE01	RE1	19900906	0.03	0.08<	0.018	0.013<	0.13	0.020<	0.12+	0.232+		6.7	0.034	5.679^	21.0	802	3.89
3319DD00051	RE01	RE1	19901203	0.00	0.14	0.060	0.029	0.00	0.020<	0.61+	0.034		10.0	0.146	0.082		251	5.76
3319DD00051	RE01	RE1	19910304	0.00	0.08<	0.013	0.050	0.75	0.020<	0.17+	0.057+		5.1	0.438	0.438		902	-3.47
3319DD00052	RE02	RE2	19881026			0.129							14.4	0.329			409	3.60
3319DD00052	RE02	RE2	19890426			0.000						0.01	3.2	0.380			300	-0.76
3319DD00052	RE02	RE2	19900607	0.15	0.08<	0.107	0.013	0.13	0.022	0.38+	1.021^	0.00	5.6	0.226	0.321		346	1.97
3319DD00052	RE02	RE2	19900905	0.14	0.08<	0.013	0.013<	0.50	0.020<	0.02<	0.025<		13.8	0.778	10.439^	20.0	351	0.11
3319DD00052	RE02	RE2	19901203	0.00	0.08<	0.016	0.072	0.53	0.020<	0.19+	0.025<		7.0	0.629	3.842+		781	0.40
3319DD00053	RL01	RL1	19900606	0.00	0.21+	0.342	0.065	0.39	0.020<	4.90^	1.504^	0.00	8.0	0.141	0.225	20.6	409	2.06
3319DD00053	RL01	RL1	19900904	0.00	0.08<	0.048	0.013<	0.15	0.020<	0.20+	2.601^		10.3	0.035	0.044	21.5	602	-3.29
3319DD00053	RL01	RL1	19901204	0.00	0.08<	0.243	0.133	1.16	0.020<	6.91^	4.061^		15.4	0.390	0.258		1160	-0.03
3319DD00053	RL01	RL1	19910228	0.00	0.08<	0.239	0.180	1.35	0.020<	10.10^	4.256^		13.2	0.374	0.211	23.0	1137	-2.04
3319DD00054	TY01	TY1	19900606	0.00	0.17+	0.040	0.013<	0.02	0.040	0.63+	0.031	0.00	4.9	0.041	0.072	15.8	139	0.45
3319DD00054	TY01	TY1	19900904	0.00	0.08<	0.066	0.013<	0.13	0.020<	0.51+	0.025<		7.2	0.052	0.041	21.0	125	-1.51
3319DD00054	TY01	TY1	19901204	0.00	0.08<	0.147	0.013<	0.24	0.020<	0.45+	0.139+		10.6	0.061	0.116		202	-2.82
3319DD00054	TY01	TY1	19910228	0.00	0.08<	0.058	0.013<	0.11	0.020<	0.11+	0.025<		7.1	0.026	0.045	25.0	122	-1.84
3319DD00055	TY02	TY2	19900606	0.00	0.08<	0.149	0.013<	0.21	0.026	0.09	0.139+	0.00	9.8	0.058	0.057	20.0	183	1.54
3319DD00055	TY02	TY2	19900904	0.00	0.08<	16.700^	0.013<	0.00	0.020<	5.86^	2.611^		17.6	0.136	0.197	22.2	299	1.67
3319DD00055	TY02	TY2	19901204	0.00	0.08<	0.084	0.013<	0.00	0.020<	0.33+	0.065+		8.9	0.035	0.080		137	-1.41
3319DD00055	TY02	TY2	19910228	0.00	0.08	0.126	0.013<	0.23	0.021	0.15+	0.107+		10.2	0.052	0.048	21.6	179	-2.68
3319DD00057	TY04	TY4	19900606	0.00	0.08<	0.080	0.013<	0.09	0.025	0.22+	0.075+	0.00	8.3	0.036	0.068	21.5	145	2.91
3319DD00057	TY04	TY4	19900904	0.00	0.08<	0.095	0.013<	0.37	0.020<	0.23+	0.054+		9.1	0.110	0.094	22.5	153	1.44
3319DD00057	TY04	TY4	19901204	0.00	0.08<	0.060	0.013<	0.11	0.020<	0.29+	0.039		7.4	0.028	0.099		119	1.59
3319DD00057	TY04	TY4	19910228	0.00	0.08<	0.071	0.013<	0.13	0.020<	0.09	0.055+		8.2	0.030	0.042	22.8	123	-4.19
3319DD00058	VD02	VD2	19900606	0.00	0.08<	0.130	0.013<	0.12	0.020<	0.15+	2.067^	0.00	10.2	0.124	0.087	18.8	208	-1.04
3319DD00058	VD02	VD2	19900904	0.50	0.08<	0.046	0.464	1.94	0.020<	0.37+	0.370+		5.0	1.453	0.407	18.0	171	2.14
3319DD00058	VD02	VD2	19901204	0.00	0.08<	0.185	0.033	0.24	0.020<	0.46+	4.154^		12.6	0.257	0.058	23.0	397	-0.74
3319DD00058	VD02	VD2	19910228	0.00	0.08<	0.120	0.136	1.65	0.020<	8.54^	6.655^		15.4	0.839	0.260	24.0	1564	-3.85
3319DD00059	VD03	VD3	19900606	0.00	0.08<	0.240	0.013<	0.02	0.020<	0.40+	1.176^	0.00	15.0	0.088	0.075	21.5	156	-0.26
3319DD00059	VD03	VD3	19900904	0.03	0.08<	0.052	0.029	0.08	0.020<	1.16^	1.429^		17.1	0.118	0.108	21.8	149	3.89
3319DD00059	VD03	VD3	19901204	0.00	0.08<	0.242	0.124	0.48	0.020<	1.05^	2.427^		13.8	0.540	0.151	24.0	735	6.10
3319DD00059	VD03	VD3	19910228	0.00	0.08<	0.174	0.038	0.59	0.020<	2.30^	3.725^		16.8	0.364	0.058	23.8	540	-2.21
3319DD00060	VD04	VD4	19900606	0.00	0.21+	0.006	0.464	1.24	0.031	0.23+	0.070+	0.00	12.0	1.078	0.157		1977	-3.90
3319DD00060	VD04	VD4	19900904	0.17	0.08<	0.026	0.209	0.80	0.020<	0.02<	0.041		13.0	0.575	0.027		2062	0.32
3319DD00060	VD04	VD4	19901204	0.00	0.08<	0.059	0.465	1.73	0.020<	0.30+	0.025<		13.9	1.069	0.152		2138	0.02
3319DD00060	VD04	VD4	19910228	0.00	0.08<	0.043	0.302	0.00	0.023	0.20+	0.059+		8.8	0.821	0.077		1520	-2.21

Site id	# on map	Sample #	Date	NO2-N mg/L	Al mg/L	Ba mg/L	B mg/L	Br mg/L	Cu mg/L	Fe mg/L	Mn mg/L	PO4 mg/L	Si mg/L	Sr mg/L	Zn mg/L	Temp. C	TDS () mg/L	Ion-ba %
3319DD00066	ZN01	ZN01	19900601	0.02	0.08<	0.163	0.013	0.00	0.021	1.76^	1.376^	0.00	23.0	0.136	0.036	16.0	176	7.94
3319DD00066	ZN01	ZN1	19900907	0.00	0.08<	0.117	0.000	0.00	0.000	0.03	0.905+		26.1	0.136	0.030		174	0.99
3319DD00066	ZN01	ZN1	19901205	0.00	0.24+	0.202	0.013<	0.00	0.020<	1.30^	0.636+		19.5	0.211	0.073		223	1.42
3319DD00066	ZN01	ZN1	19910227	0.00	0.08<	0.227	0.013<	0.08	0.020<	0.24+	0.655+		18.6	0.215	0.019	24.2	204	3.33
3319DD00067	ZN02	ZN2	19900601	0.00	0.08<	0.132	0.151	2.95	0.041	0.98+	1.947^	0.00	9.7	2.786	0.044	17.3	2366	-3.20
3319DD00067	ZN02	ZN2	19900907	0.00	0.08<	0.117	0.013<	0.00	0.020<	0.04	0.025<		4.0	0.136	0.030		1282	-1.11
3319DD00067	ZN02	ZN2	19901205	0.00	0.08<	0.163	0.136	1.96	0.020<	0.29+	0.262+		12.1	0.959	0.072		1555	-4.90
3319DD00067	ZN02	ZN2	19910227	0.00	0.08<	0.080	0.274	3.63	0.025	0.24+	1.341^		10.8	1.862	0.055	25.0	3066	-1.14
3319DD00068	ZN03	ZN3	19881025			0.052							15.0	0.061			96	6.44
3319DD00068	ZN03	ZN3	19890426			0.025						0.09	15.0	0.052			109	1.17
3319DD00068	ZN03	ZN3	19900601	0.03	0.08<	0.023	0.013<	0.02	0.075	2.64^	0.025<	0.00	16.4	0.059	0.049	18.5	185	-13.40
3319DD00068	ZN03	ZN3	19900907	0.44	0.08<	0.049	0.013<	1.67	0.020<	0.04	0.025<		16.2	1.261	0.053		116	2.49
3319DD00068	ZN03	ZN3	19901205	0.00	0.08<	0.019	0.013<	0.00	0.020<	0.20+	0.025<		17.6	0.050	0.152		114	8.07
3319DD00068	ZN03	ZN3	19910227	0.00	0.08<	0.011	0.013<	0.07	0.020<	0.07	0.025<		17.1	0.031	0.034	27.8+	104	6.02
3319DD00105	R21		19881024			0.152							4.0	2.152			2737	-0.95
3319DD00105	R21		19890426			0.004<						0.02	4.8	0.219			429	-0.79
3319DD00106	H4M19	H4M19	19881025			0.136							6.2	1.728			2099	0.47
3319DD00106	H4M19	H4M19	19890426			0.047						0.02	5.1	0.510			620	-0.40
3319DD00106	H4M19	H4M19	19900530	0.44	0.08<	0.105	0.278	2.96	0.020<	0.05	0.025<	0.00	7.0	1.571	0.025	16.0	2328	-2.93
3319DD00106	H4M19	H4M19	19900622	0.00	0.08<	0.063	0.150	1.58	0.020<	0.03	0.025<		5.7	0.994	0.035		1415	0.47
3319DD00106	H4M19	H4M19	19900723	1.48	0.08<	0.002	1.514+	6.04	0.020<	0.28+	0.025<		5.8	0.105	0.022		1437	-0.60
3319DD00106	H4M19	H4M19	19900905	0.05	0.08<	0.019	0.013<	0.14	0.020<	0.05	0.025<		4.2	0.294	0.022		1819	-1.85
3319DD00106	H4M19	H4M19	19900926	0.00	0.08<	0.067	0.024	2.26	0.020<	0.13+	0.025<		3.9	1.259	0.058		1949	-2.13
3319DD00106	H4M19	H4M19	19901026	0.00	0.08<	0.057	0.191	1.59	0.020<	0.20+	0.025<		3.8	1.092	0.005<		2056	-12.62
3319DD00106	H4M19	H4M19	19901127	0.00	0.08<	0.080	0.333	2.42	0.020<	0.05	0.025<		5.6	1.329	0.049	24.4	2138	-1.72
3319DD00106	H4M19	VINK	19901205	0.00	0.08<	0.080	0.322	2.59	0.020<	0.22+	0.025<		7.1	1.428	0.098		2255	-1.07
3319DD00106	H4M19	VINK	19901219	0.00	0.08<	0.077	0.035	2.64	0.020<	0.08	0.025<		6.2	1.439	0.039	18.5	2126	-0.40
3319DD00106	H4M19	VINK	19910123	0.00	0.08<	0.095	0.440	2.72	0.020<	0.02<	0.037		7.7	1.603	0.073	20.2	2419	0.73
3319DD00106	H4M19	VINK	19910213	0.00	0.08<	0.096	0.431	3.64	0.023	0.28+	0.174+		8.3	1.567	0.093		2417	0.51
3319DD00106	H4M19	VINK	19910304	0.00	0.08<	0.074	0.314	1.95	0.020<	0.22+	0.025<		6.5	1.218	0.019		1840	-1.36
3319DD00106	H4M19	VINK	19910320	0.00				3.11				0.00					2329	3.88
3319DD00106	H4M19	VINK	19910424	0.00				2.72				0.00					2526	-0.63
3319DD00107	R35		19881024			0.053							2.4	0.023			37	4.59
3319DD00107	R35		19890426			0.043						0.07	6.6	0.480			542	-2.53
3319DD00108	H4M16		19881025			0.100							8.8	1.188			2953	1.03
3319DD00108	H4M16		19890426										4.0				632	-1.30
3319DD00109	B5		19881025			0.087							8.0	1.201			2193	0.55
3319DD00109	B5		19890426			0.036						0.02	7.7	0.341			780	-2.10
3319DD00109	B5	B5	19900606	0.00	0.08<	0.012	0.078	2.06	0.026	0.93+	0.040	0.00	1.0	0.263	0.521	13.5	1276	4.92
3319DD00109	B5	B5	19901204	0.00	0.08<	0.037	0.313	1.62	0.020<	1.75^	0.545+		8.7	0.817	0.967	26.0+	1497	16.76
3319DD00109	B5	B5	19910228	0.00	0.08<	0.034	0.311	1.93	0.020<	0.80+	0.592+		8.2	0.881	0.234	23.0	2132	-1.33
3319DD00111	Z	Z	19900605	0.00	0.08<	0.017	0.045	0.35	0.020<	0.04	0.025<	0.00	6.8	0.358	0.103		515	0.33
3319DD00111	Z	Z	19900903	0.09	0.08<	0.013	0.048	0.28	0.020<	0.02<	0.025<		7.0	0.387	0.052		451	0.52
3319DD00111	Z	Z	19901203	0.00	0.08<	0.019	0.073	0.24	0.020<	0.33+	0.025<		7.2	0.349	0.052	19.0	525	0.32
3319DD00111	Z	Z	19910226	0.00	0.08<	0.023	0.078	0.65	0.021	0.17+	0.025<		7.6	0.420	0.025	21.0	666	-3.89
3319DD00112	AA	AA	19900605	0.00	0.08<	0.018	0.031	0.24	0.020<	0.04	0.025<	0.00	6.5	0.323	0.034	17.0	483	-1.35
3319DD00112	AA	AA	19900903	0.29	0.08<	0.015	0.103	1.35	0.020<	0.03	0.025<		6.4	1.599	0.058		424	-0.32
3319DD00112	AA	AA	19901203	0.00	0.08<	0.019	0.063	0.38	0.020<	0.03	0.025<		7.1	0.344	0.056	19.0	515	0.26

187

Site id	# on map	Sample #	Date	NO2-N mg/L	Al mg/L	Ba mg/L	B mg/L	Br mg/L	Cu mg/L	Fe mg/L	Mn mg/L	PO4 mg/L	Si mg/L	Sr mg/L	Zn mg/L	Temp. C	TDS () mg/L	Ion-ba t
3319DD00113	NELS	NELS	19900530	0.00	0.08<	0.010	0.013<	0.00	0.020<	0.05	0.025<	0.00	4.6	0.096	0.029	18.0	151	3.65
3319DD00113	NELS	NELS	19900622	0.00	0.08<	0.009	0.013<	0.00	0.020<	0.09	0.025<	0.00	3.0	0.062	0.039		121	11.91
3319DD00113	NELS	NELS	19900723	0.00	0.08<	0.009	0.047	0.16	0.020<	0.05	0.025<		5.3	0.183	0.018		232	1.94
3319DD00113	NELS	NELS	19900900	0.00	0.08<	0.023	0.071	0.24	0.020<	0.02<	0.025		7.0	0.275	0.042		451	-2.14
3319DD00113	NELS	NELS	19900905	0.48	0.08<	0.038	0.160	1.88	0.025<	0.16+	0.025<		5.7	1.002	0.027		352	-0.69
3319DD00113	NELS	NELS	19901000	0.00	0.08<	0.028	0.055	0.29	0.020<	0.19+	0.025<		6.2	0.289	0.019		448	-0.92
3319DD00113	NELS	NELS	19901205	0.00	0.08<	0.030	0.065	0.28	0.020<	0.31+	0.058+		4.4	0.245	0.055		408	-3.74
3319DD00113	NELS	NELS	19910304	0.00	0.08<	0.027	0.042	0.21	0.020<	2.27^	0.180+		5.9	0.242	0.034		360	-2.34
3319DD00114	AE	AE	19900607	0.00	0.22+	0.080	0.111	0.15	0.029	0.32+	0.025<	0.00	14.1	0.317	0.117		529	2.23
3319DD00115	AC	AC	19900607	0.00	0.08<	0.020	0.062	0.47	0.020<	0.25+	0.287+	0.00	9.2	0.461	0.054	20.0	645	-1.77
3319DD00116	AD	AD	19900607	0.00	0.08<	0.014	0.018	0.49	0.020<	0.07	0.032	0.00	8.3	0.305	0.027	18.5	560	-2.93
3319DD00117	AG	AG	19900608	0.00	0.08	0.016	0.013<	0.04	0.020<	0.30+	0.033	0.00	1.6	0.049	0.023		90	2.47
3319DD00118	LE01	LE1	19900609	0.00	0.09	0.028	0.013	0.15	0.020<	0.02	0.025<	0.16	17.8	0.082	0.092		189	1.95
3319DD00118	LE01	LE1	19900906	0.00	0.08<	0.028	0.013<	0.06	0.020<	0.02<	0.025<		18.1	0.112	0.017		189	1.75
3319DD00118	LE01	LE1	19901207	0.00	0.08<	0.039	0.029	0.12	0.020<	0.24+	0.025<		18.9	0.090	0.023		198	2.78
3319DD00118	LE01	LE1	19910304	0.00	0.08<	0.045	0.013<	0.08	0.020<	0.20+	0.025<		18.6	0.094	0.026		206	0.54
3319DD00119	H4H11	KEISERS	19900530	0.28	0.16+	0.037	0.607+	2.49	0.020<	0.78+	0.884+	0.00	5.0	0.738	0.016	16.0	2349	-3.22
3319DD00119	H4H11	KEISERS	19900621	0.00	0.09	0.035	0.518+	2.10	0.020<	0.44+	0.077+	0.00	6.2	0.695	0.034		2152	-1.43
3319DD00119	H4H11	KEISERS	19900723	0.22	0.16+	0.046	0.214	1.32	0.020<	0.41+	0.044		6.3	1.252	0.025		2107	0.73
3319DD00119	H4H11	KEISERS	19900900	0.00	0.13	0.038	0.694+	2.99	0.020<	0.27+	0.052+		3.1	0.834	0.030		2606	-2.27
3319DD00119	H4H11	KEISERS	19901025	0.00	0.08<	0.047	1.007+	3.50	0.020<	0.16+	0.025<		1.9	1.138	0.005<		3307	5.28
3319DD00119	H4H11	KEISERS	19901127	0.00	0.08<	0.050	1.181+	3.92	0.020<	0.02<	0.025<		1.7	1.284	0.013	29.4+	3969	-1.24
3319DD00119	H4H11	KEISERS	19901205	0.00	0.08<	0.051	1.236+	4.34	0.020<	0.72+	0.025<		2.5	1.333	0.189		4023	-4.98
3319DD00119	H4H11	KEISERS	19901218	0.00	0.08<	0.050	1.046+	3.67	0.020<	0.17+	0.629+		3.1	1.276	0.076		3633	-0.92
3319DD00119	H4H11	KEISERS	19910122	0.00	0.08<	0.064	1.662+	6.86	0.026	0.02<	0.025<		5.1	1.741	0.017		5075	3.30
3319DD00119	H4H11	KEISERS	19910212	0.00	0.08<	0.062	1.468+	4.83	0.020<	0.02<	0.033		5.3	1.550	0.026		4496	2.90
3319DD00119	H4H11	KEISERS	19910305	0.00	0.10	0.055	1.378+	3.84	0.020<	0.32+	0.055+		5.3	1.497	0.018		4293	-0.42
3319DD00119	H4H11	KEISERS	19910319	0.00				3.64				0.00					3063	-1.15
3319DD00119	H4H11	KEISERS	19910423	0.00				4.62				0.00					4537	-1.69
3319DD00120	P	P	19900602	0.00	0.08<	0.125	0.013<	0.03	0.020<	0.22+	0.076+	0.00	4.4	0.199	0.686	20.0	223	6.13
3319DD00120	P	P	19900905	0.00	0.08<	0.034	0.019	0.00	0.020<	0.02<	0.050		4.7	0.053	0.035	21.0	203	1.56
3319DD00120	P	P	19901205	0.00	0.08<	0.113	0.013<	0.00	0.020<	0.49+	0.886+		3.3	0.231	0.381		195	2.56
3319DD00120	P	P	19910227	0.00	0.08<	0.114	0.013<	0.00	0.020<	0.12+	0.099+		4.9	0.168	0.453	20.6	252	-17.28
3319DD00121	Q	Q	19900602	0.00	0.08<	0.005	0.258	3.98	0.020<	0.02<	0.025<	0.00	2.7	0.089	0.034	18.0	5106	-0.63
3319DD00122	R	R	19900602	0.03	0.12	0.313	0.013<	0.21	0.022	0.96+	1.617^	0.00	12.2	0.157	0.430	17.0	283	6.48
3319DD00123	S	S	19900602	0.03	0.08<	0.256	0.013<	0.09	0.022	4.72^	1.794^	0.00	12.1	0.132	0.445	18.0	219	5.61
3319DD00124	CD1A	CD1A	19900601	0.00	0.08<	0.042	0.013<	0.02	0.020<	0.09	0.850+	0.00	14.9	0.044	0.159	24.0	110	7.97
3319DD00124	CD1A	CD1A	19900905	0.04	0.08<	0.155	0.023	0.12	0.020<	0.03	0.841+		16.5	0.488	0.030	26.0+	116	0.72
3319DD00124	CD1A	CD1A	19901205	0.00	0.08<	0.005	0.072	0.00	0.020<	0.20+	0.025<		11.0	0.134	0.077		141	-4.99
3319DD00124	CD1A	CD1A	19910227	0.00	0.08<	0.034	0.013<	0.15	0.020<	0.09	0.762+		15.5	0.040	0.019	26.0+	120	-5.44
3319DD00125	N	N	19900601	0.00	0.08<	0.135	0.013<	0.00	0.020<	0.71+	0.726+	0.00	18.4	0.258	0.195	19.0	220	2.60
3319DD00125	N	N	19900905	0.14	0.08<	0.018	0.111	0.85	0.020<	0.41+	1.078^		19.0	0.713	0.054	21.8	275	0.82
3319DD00125	N	N	19901205	0.00	0.08<	0.288	0.013	0.32	0.020<	1.03^	1.949^		18.0	0.694	2.038+		523	-1.08
3319DD00125	N	N	19910227	0.00	0.80<	0.279	0.013<	0.68	0.020<	0.94+	1.847^		17.1	0.680	0.016	21.8	491	-1.29
3319DD00126	HOOPS	HOOPS	19900609	0.00	0.11	0.045	0.166	1.00	0.020<	0.06	0.025<	0.00	9.7	0.451	0.095		985	0.54
3319DD00126	HOOPS	HOOPS	19900621	0.00	0.25+	0.035	0.048	0.55	0.020<	0.23+	0.025<	0.00	3.8	0.302	0.051		495	2.41
3319DD00126	HOOPS	HOOPS	19900723	0.00	0.08<	0.012	0.052	0.18	0.020<	0.02<	0.025<		10.4	0.156	0.015		1271	2.63
3319DD00126	HOOPS	HOOPS	19900900	0.00	0.08<	0.078	0.299	1.45	0.020<	0.35+	0.399+		10.9	0.694	0.047		1741	-6.04

188

Site id	# on map	Sample #	Date	NO2-N mg/L	Al mg/L	Ba mg/L	B mg/L	Br mg/L	Cu mg/L	Fe mg/L	Mn mg/L	PO4 mg/L	Si mg/L	Sr mg/L	Zn mg/L	Temp. C	TDS () mg/L	Ion-ba %
3319DD00126	HOOPS	HOOPS	19900905	0.72	0.08<	0.059	0.117	2.10	0.020<	0.16+	0.061+		6.6	1.626	0.014		933	-2.76
3319DD00126	HOOPS	HOOPS	19901025	0.00	0.15	0.059	0.247	1.29	0.020<	0.56+	0.034		9.1	0.588	0.018		1377	-2.91
3319DD00126	HOOPS	HOOPS	19901127	0.00	0.08<	0.073	0.328	1.34	0.020<	0.20+	0.205+		10.9	0.685	0.069		1625	-1.37
3319DD00126	HOOPS	HOOPS	19901205	0.00	0.08<	0.081	0.351	1.79	0.020<	0.29+	0.031		13.4	0.827	0.105		1823	0.07
3319DD00126	HOOPS	HOOPS	19901218	0.00	0.08<	0.067	0.346	2.06	0.020<	0.02<	0.025<		12.0	0.793	0.006		1766	-2.14
3319DD00126	HOOPS	HOOPS	19910122	0.00	0.08<	0.083	0.418	2.10	0.020<	0.02<	0.034		12.9	0.934	0.026		1991	-0.82
3319DD00126	HOOPS	HOOPS	19910213	0.00	0.08<	0.089	0.532+	3.06	0.036	0.05	0.096+		14.2	1.051	0.118		2357	1.86
3319DD00126	HOOPS	HOOPS	19910305	0.00	0.08<	0.121	0.396	2.46	0.020<	0.34+	0.485+		13.5	0.976	0.047		2120	-0.98
3319DD00126	HOOPS	HOOPS	19910319	0.00				1.23				0.00					1086	4.65
3319DD00126	HOOPS	HOOPS	19910423	0.00				2.05				1.54					1718	0.28
3319DD00127	AF	AF	19900608	0.00	0.08<	0.198	0.013<	0.00	0.023	2.21^	1.150^	0.00	15.7	0.109	0.240	21.6	156	1.61
3319DD00127	AF	AF	19900904	0.00	0.08<	0.110	0.013<	0.00	0.020<	1.08^	1.138^		18.3	0.305	0.081	22.2	158	3.21
3319DD00127	AF	AF	19901204	0.00	0.08<	0.193	0.016	0.00	0.020	0.57+	1.022^		17.5	0.104	0.101	24.0	162	5.61
3319DD00127	AF	AF	19910228	0.00	0.08<	0.196	0.013<	0.00	0.020<	0.87+	1.091^		16.9	0.102	0.215		179	-4.35
3319DD00128	ROB01	ROB01	19900621	0.00	0.08<	0.019	0.013<	0.25	0.020<	0.28+	0.025<		1.8	0.136	0.033		276	2.38
3319DD00128	ROB01	ROB01	19900723	0.00	0.08<	0.011	0.033	0.00	0.020<	0.30+	0.025<		2.6	0.116	0.014		243	22.85
3319DD00128	ROB01	ROB01	19900900	0.00	0.08<	0.015	0.032	0.24	0.020<	0.21+	0.025<		1.3	0.118	0.033		239	1.44
3319DD00128	ROB01	ROB01	19901130	0.00	0.08<	0.015	0.055	0.00	0.020<	0.20+	0.025<		0.4	0.106	0.099		211	1.19
3319DD00128	ROB01	ROB01	19901218	0.10	0.08<	0.014	0.044	0.28	0.020<	0.23+	0.025<		0.5	0.101	0.044		184	0.68
3319DD00128	ROB01	ROB01	19910122	0.00	0.08<	0.012	0.074	0.20	0.025	0.14+	0.025<		0.4	0.068	0.136		145	-1.58
3319DD00128	ROB01	ROB01	19910319	0.00				0.00				0.47					161	5.33
3319DD00128	ROB01	ROB01	19910423	0.00				0.00				0.00					192	9.09
3319DD00129	VOOGDS_KLEIN	VOOGDS_K	19900621	0.00	0.08<	0.067	0.380	2.41	0.020<	0.02<	0.025<		6.2	0.795	0.037		1931	-0.67
3319DD00129	VOOGDS_KLEIN	VOOGDS_K	19900723	0.00	0.08<	0.059	0.483	2.77	0.020<	0.02<	0.025<		5.4	1.246	0.016		2300	1.06
3319DD00129	VOOGDS_KLEIN	VOOGDS_K	19900900	0.00	0.08<	0.066	0.441	2.94	0.020<	0.02<	0.025<		4.5	0.804	0.032		2038	-2.80
3319DD00129	VOOGDS_KLEIN	VOOGDS_K	19901025	0.00	0.08<	0.073	0.418	2.45	0.020<	0.11+	0.025<		4.6	0.849	0.005<		2151	-0.23
3319DD00129	VOOGDS_KLEIN	VOOGDS_K	19901130	0.00	0.11	0.059	0.453	1.45	0.020<	0.35+	0.032		6.2	0.653	0.038		1744	-0.99
3319DD00129	VOOGDS_KLEIN	VOOGDS_K	19901218	0.00	0.08<	0.104	0.615+	3.23	0.020<	0.02<	0.026		8.0	1.197	0.022		2838	2.22
3319DD00129	VOOGDS_KLEIN	VOOGDS_K	19910122	0.00	0.08<	0.131	0.868+	4.26	0.057	0.02<	0.025<		10.8	1.502	0.005<		3339	2.21
3319DD00129	VOOGDS_KLEIN	VOOGDS_K	19910212	0.00	0.08<	0.056	0.496	1.98	0.046	0.18+	0.054+		8.0	0.724	0.094		1797	1.72
3319DD00129	VOOGDS_KLEIN	VOOGDS_K	19910319	0.00				1.38				0.00					1479	2.54
3319DD00129	VOOGDS_KLEIN	VOOGDS_K	19910423	0.00				1.92				0.00					1727	0.23
3319DD00130	VOOGDS_GROOT	VOOGDS_G	19900625	0.00	0.08<	0.053	0.329	1.86	0.020<	0.07	0.025<		7.3	0.599	0.028		1634	-0.39
3319DD00130	VOOGDS_GROOT	VOOGDS_G	19900723	0.09	0.08<	0.043	0.387	1.08	0.020<	0.17+	0.025<		7.1	0.775	0.044		1668	-1.38
3319DD00130	VOOGDS_GROOT	VOOGDS_G	19900900	0.00	0.08<	0.041	0.219	1.10	0.020<	0.18+	0.025<		4.7	0.388	0.018		1062	-3.38
3319DD00130	VOOGDS_GROOT	VOOGDS_G	19901025	0.00	0.08<	0.047	0.331	1.55	0.020<	0.15+	0.025<		5.8	0.520	0.005<		1449	-1.71
3319DD00130	VOOGDS_GROOT	VOOGDS_G	19901130	0.00	0.08<	0.075	0.435	2.12	0.020<	0.14+	0.025<		6.7	0.810	0.124		1919	-2.58
3319DD00130	VOOGDS_GROOT	VOOGDS_G	19901218	0.00	0.08<	0.058	0.444	1.75	0.020<	0.09	0.025<		6.5	0.721	0.035		1885	-1.67
3319DD00130	VOOGDS_GROOT	VOOGDS_G	19910122	0.00	0.08<	0.057	0.471	2.10	0.020<	0.04	0.025<		6.8	0.756	0.046		1796	-1.23
3319DD00130	VOOGDS_GROOT	VOOGDS_G	19910212	0.00	0.08<	0.103	0.849+	4.34	0.023	0.02<	0.025<		10.0	1.303	0.042		2291	39.59
3319DD00130	VOOGDS_GROOT	VOOGDS_G	19910319	0.00				2.06				1.18					1721	1.67
3319DD00130	VOOGDS_GROOT	VOOGDS_G	19910423	0.00				1.55				0.00					1484	1.88
3319DD00131	ANG01	ANG01	19900621	0.00	0.08<	0.020	0.013<	0.29	0.020<	0.31+	0.025<		2.4	0.146	0.032		303	5.92
3319DD00131	ANG01	ANG01	19900723	0.03	0.08<	0.013	0.054	0.17	0.020<	0.34+	0.025<		4.4	0.151	0.031		260	0.63
3319DD00131	ANG01	ANG01	19900900	0.00	0.08<	0.013	0.043	0.29	0.020<	0.22+	0.025<		1.2	0.125	0.024		272	-0.35
3319DD00131	ANG01	ANG01	19901025	0.00	0.08<	0.018	0.066	0.31	0.020<	0.17+	0.025<		0.7	0.167	0.014		350	-0.98
3319DD00131	ANG01	ANG01	19901218	0.00	0.08<	0.020	0.087	0.29	0.020<	0.19+	0.025<		0.6	0.149	0.033		285	0.98
3319DD00131	ANG01	ANG01	19910122	0.00	0.08<	0.016	0.077	0.21	0.020<	0.56+	0.025<		0.5	0.175	0.067		247	19.05

Site id	# on map	Sample #	Date	NO2-N mg/L	Al mg/L	Ba mg/L	B mg/L	Br mg/L	Cu mg/L	Fe mg/L	Mn mg/L	PO4 mg/L	Si mg/L	Sr mg/L	Zn mg/L	Temp. C	TDS () mg/L	Ion-ba t
3319DD00131	ANG01	ANG01	19910212	0.00	0.08<	0.018	0.072	0.24	0.049	0.37+	0.030		0.3	0.139	0.043		302	0.75
3319DD00131	ANG01	ANG01	19911127	0.00	0.08<	0.015	0.086	0.21	0.020<	0.23+	0.025<		0.8	0.157	0.035		348	-7.62
3319DD00132	SAN01	SAN01	19900621	0.00	0.08<	0.019	0.018	0.31	0.020<	0.36+	0.025<		3.1	0.140	0.034		311	2.42
3319DD00132	SAN01	SAN01	19900723	0.00	0.08<	0.006	0.044	0.51	0.020<	0.25+	0.025<		2.6	0.104	0.022		230	9.29
3319DD00132	SAN01	SAN01	19900900	0.00	0.08<	0.018	0.055	0.21	0.020<	0.18+	0.025<		1.1	0.153	0.037		292	4.76
3319DD00132	SAN01	SAN01	19901025	0.00	0.08<	0.017	0.076	0.29	0.020<	0.19+	0.025<		0.8	0.188	0.011		396	-2.77
3319DD00132	SAN01	SAN01	19901130	0.00	0.08<	0.021	0.113	0.41	0.020<	0.20+	0.025<		0.9	0.198	0.050	23.5	401	-0.47
3319DD00132	SAN01	SAN01	19901218	0.00	0.08<	0.021	0.116	0.46	0.020<	0.19+	0.025<		0.9	0.188	0.036	23.4	358	11.84
3319DD00132	SAN01	SAN01	19910122	0.00	0.08<	0.015	0.085	0.35	0.020<	0.06	0.025<		0.3	0.147	0.045		279	0.34
3319DD00132	SAN01	SAN01	19910212	0.00	0.08<	0.018	0.109	0.33	0.037	0.19+	0.035		0.1	0.164	0.116		331	2.61
3319DD00132	SAN01	SAN01	19910320	0.00			0.32					0.00					337	4.14
3319DD00133	SAND	SAND	19900622	0.00	0.08<	0.025	0.139	0.53	0.020<	0.03	0.025<		12.4	0.270	0.045		653	2.59
3319DD00133	SAND	SAND	19900723	3.26	0.08<	0.094	2.394^	28.32	0.070	0.15+	0.025<		5.3	13.378	0.005<		173	3.33
3319DD00133	SAND	SANDRIV	19900900	0.00	0.08<	0.030	0.275	0.60	0.020<	0.16+	0.025<		15.7	0.341	0.035		1046	-10.06
3319DD00133	SAND	SANDRIV	19901000	0.00	0.10	0.036	0.318	0.80	0.020<	0.25+	0.025<		14.9	0.351	0.005		1022	-0.31
3319DD00133	SAND	SANDRIV	19901127	0.00	0.11	0.043	0.463	0.68	0.020<	0.15+	0.025<		18.2	0.405	0.046		1196	-0.21
3319DD00133	SAND	SANDRIV	19901218	0.00	0.08<	0.035	0.498	0.76	0.020<	0.02<	0.025<		18.0	0.451	0.013		1238	3.91
3319DD00133	SAND	SANDRIV	19910122	0.00	0.08<	0.043	0.502+	0.51	0.020<	0.02	0.025<		19.5	0.424	0.035		1228	-0.35
3319DD00133	SAND	SANDRIV	19910213	0.00	0.08<	0.045	0.569+	0.78	3.500^	0.02<	0.025<		21.1	0.469	0.027		1334	5.93
3319DD00133	SAND	SANDRIV	19910320	0.00			1.06					1.27					1432	-0.45
3319DD00133	SAND	SANDRIV	19910424	0.00			0.47					0.00					1374	0.07
3319DD00134	TY_5TG	SIG	19900904	0.00	0.16+	0.018	0.052	0.15	0.020<	0.41+	0.025<		13.0	0.210	0.030		1552	1.54
3319DD01593	G33593	G33593	19900620	0.00	0.08<	0.005	1.603+	6.10	0.020<	0.03	0.030	0.00	0.7	0.081	0.031		3968	-0.73
3319DD01593	G33593	G33593	19900727	2.59	0.08<	0.014	1.663+	6.97	0.020<	0.02<	0.025<		1.0	0.299	0.036		4349	-0.35
3319DD01593	G33593	G33593	19900900	0.00	0.08<	0.006	1.313+	5.91	0.020<	0.00	0.028		1.3	0.185	0.053	0.0	4367	-3.14
3319DD01593	G33593	G33593	19901000	0.00	0.08<	0.017	1.417+	6.58	0.020<	0.28+	0.113+		1.2	0.234	0.005<		4561	1.71
3319DD01593	G33593	G33593	19901220	0.00	0.08<	0.060	1.155+	2.09	0.020<	0.06	0.025<		1.1	0.138	0.052		2459	45.35
3319DD01593	G33593	G33593	19910131	0.00	0.08<	0.010	1.410+	7.30	0.020<	0.14+	0.025<		0.7	0.143	0.038		4261	0.90
3319DD01593	G33593	G33593	19910305	0.00			0.38					0.00					367	9.58
3319DD01593	G33593	G33593	19910426	0.00			0.35					0.00					423	-1.11
3319DD01594	G33594	G33594	19900620	0.00	0.08<	0.050	1.316+	6.80	0.020<	1.29^	0.121+		1.1	0.219	0.024		3843	-0.94
3319DD01594	G33594	G33594	19900727	0.00	0.08<	0.043	0.998+	7.38	0.020<	0.02<	0.470+		1.3	2.628	0.017		4119	1.44
3319DD01594	G33594	G33594	19900900	0.00	0.08<	0.051	1.091+	6.62	0.020<	0.12+	0.025<		0.7	0.137	0.057		3790	-1.55
3319DD01594	G33594	G33594	19901000	0.00	0.08<	0.056	1.062+	6.78	0.020	0.30+	0.025<		1.1	0.119	0.020		4188	-9.80
3319DD01594	G33594	G33594	19910305	0.00			13.18					0.00					9397	-4.90
3319DD01594	G33594	G33594	19910426	0.00			12.62					0.00					8928	-4.45
3319DD01595	G33595	G33595	19900608	0.00	0.08<	0.061	1.830+	13.70	0.020<	4.35^	0.338+		0.6	2.141	0.064		8244	0.02
3319DD01595	G33595	G33595	19900906	0.16	0.08<	0.034	0.013<	0.62	0.020<	4.94^	1.276^		1.3	0.599	0.183		8467	-2.63
3319DD01596	G33596	G33596	19900619	0.00	0.08<	0.007	2.751^	4.87	0.020<	0.02<	0.025<	0.00	2.5	0.362	0.011		5906	-0.92
3319DD01596	G33596	G33596	19900724	3.24	0.08<	0.002<	3.143^	13.39	0.043	0.02<	0.025<		3.4	4.219	0.041		6111	4.62
3319DD01596	G33596	G33596	19900900	0.00	0.08<	0.003	2.244^	5.85	0.020<	0.02<	0.025<		2.1	0.496	0.005<		6042	-2.11
3319DD01596	G33596	G33596	19901000	0.00	0.08<	0.006	2.444^	6.42	0.020<	0.34+	0.025<		1.3	0.246	0.005<		6474	-2.81
3319DD01596	G33596	G33596	19901200	0.00	1.36^	0.067	0.207	1.51	0.020<	1.88^	0.142+		6.8	0.986	0.045		1468	2.91
3319DD01596	G33596	G33596	19910131	0.00	0.56^	0.060	0.250	1.38	0.030	0.60+	0.025<		6.7	0.998	0.039		1566	-3.11
3319DD01596	G33596	G33596	19910228	0.00			13.44					0.00					8554	-2.91
3319DD01596	G33596	G33596	19910425	0.00			15.13					0.00					8596	-3.64
3319DD01598	G33598	G33598	19900620	0.00	0.08<	0.152	0.532+	1.70	0.020<	0.19+	0.025<	0.00	8.2	0.631	0.069		1438	1.47
3319DD01598	G33598	G33598	19900727	0.07	0.08<	0.013	0.348	0.40	0.020<	0.13+	0.025<		8.1	0.123	0.031		1469	0.08

190

Site id	# on map	Sample #	Date	NO2-N mg/L	Al mg/L	Ba mg/L	B mg/L	Br mg/L	Cu mg/L	Fe mg/L	Mn mg/L	PO4 mg/L	Si mg/L	Sr mg/L	Zn mg/L	Temp. C	TDS () mg/L	Ion-ba %
3319DD01598	G33598	G33598	19900900	0.00	0.08<	0.140	0.462	2.11	0.020<	0.20+	0.025<		8.1	0.592	0.051		1470	-2.96
3319DD01598	G33598	G33598	19901000	0.00	0.08<	0.156	0.509+	2.20	0.020<	0.15+	0.025<		7.9	0.681	0.051		1597	-4.59
3319DD01598	G33598	G33598	19901200	0.00	0.08<	0.020	0.161	0.56	0.020<	0.47+	0.053+		0.7	0.163	0.017		462	-2.27
3319DD01598	G33598	G33598	19910131	0.00	0.08<	0.143	0.507+	1.95	0.020	0.09	0.025<		7.8	0.623	0.087		1448	-2.01
3319DD01598	G33598	G33598	19910305	0.00				8.04				2.78					4169	-2.97
3319DD01598	G33598	G33598	19910426	0.00				8.63				0.00					4081	-2.69
3319DD01599	G33599	G33599	19900620	0.00	0.08<	0.122	1.528+	10.10	0.024	0.20+	0.863+	0.00	9.1	1.626	0.024		6772	-6.15
3319DD01599	G33599	G33599	19900700	1.42	0.08<	0.039	1.331+	5.77	0.020<	0.02<	3.043^		9.6	0.378	0.041		11985^	-1.41
3319DD01600	G33600	G33600	19900619	0.00	0.08<	0.008	0.483	3.31	0.020<	0.83+	0.097+	0.00	0.5	0.119	0.039		2236	0.40
3319DD01600	G33600	G33600	19900724	0.00	0.08<	0.028	0.628+	4.90	0.020<	0.17+	0.032		1.9	2.321	0.747		2268	3.96
3319DD01600	G33600	G33600	19900900	0.00	0.08<	0.007	0.438	3.33	0.020<	0.45+	0.149+		1.3	0.240	0.045		2272	-2.39
3319DD01600	G33600	G33600	19901000	0.00	0.08<	0.320	0.510+	2.79	0.020<	0.12+	0.172+		8.0	0.818	0.005<		2482	-1.34
3319DD01600	G33600	G33600	19901200	0.00	0.15	0.036	0.501+	3.08	0.020<	1.50^	0.134+		7.7	0.840	0.097		2259	3.13
3319DD01600	G33600	G33600	19910131	0.00	0.08<	0.032	0.507+	3.30	0.020<	1.73^	0.187+		7.7	0.776	0.033		2238	0.94
3319DD01600	G33600	G33600	19910425	0.00				1.83				0.92					1509	1.86
3319DD01601	G33601	G33601	19900619	0.00	0.08<	0.007	0.510+	6.34	0.020<	0.72+	0.146+	0.00	1.0	0.530	0.029		3892	-1.18
3319DD01601	G33601	G33601	19900724	0.91	0.08<	0.004	0.526+	2.10	0.020<	0.49+	0.078+		0.5	0.169	0.045		3893	1.30
3319DD01601	G33601	G33601	19900900	0.00	0.08<	0.005	0.394	6.77	0.020<	0.12+	0.025<		0.7	0.324	0.038		3717	-4.05
3319DD01601	G33601	G33601	19901000	0.00	0.08	0.043	0.400	5.69	0.020<	0.36+	0.025<		0.3	0.384	0.027		4018	-5.20
3319DD01601	G33601	G33601	19901220	0.00	0.08<	0.013	0.763+	1.57	0.020<	0.19+	0.025<		9.1	0.257	0.031		1592	4.75
3319DD01601	G33601	G33601	19910131	0.00	0.08<	0.011	0.784+	1.69	0.020<	0.11+	0.025<		9.6	0.252	0.084		1557	0.29
3319DD01601	G33601	G33601	19910228	0.00				5.92				2.14					3600	-1.80
3319DD01601	G33601	G33601	19910425	0.00				5.79				0.94					3848	-1.17
3319DD01602	G33602	G33602	19900619	0.00	0.08<	0.005	0.358	4.97	0.020<	1.20^	0.074+	0.00	1.2	0.169	0.031		3387	-3.26
3319DD01602	G33602	G33602	19900724	1.44	0.08<	0.004	0.542+	6.60	0.020<	0.49+	0.234+		1.0	0.587	0.032		3439	2.16
3319DD01602	G33602	G33602	19900900	0.00	0.08<	0.020	0.463	5.89	0.020<	2.81^	0.187+		7.8	1.705	0.053		3735	-2.26
3319DD01602	G33602	G33602	19901000	0.00	0.08<	0.026	0.510+	6.14	0.020<	0.29+	0.223+		8.0	1.780	0.005<		4371	-8.90
3319DD01602	G33602	G33602	19901200	0.00	0.08<	0.009	0.411	5.86	0.020<	0.83+	0.025<		0.3	0.319	0.110		3615	3.45
3319DD01602	G33602	G33602	19910131	0.00	0.08<	0.008	0.451	7.00	0.026	0.33+	0.025<		2.2	0.296	0.042		3676	-0.15
3319DD01602	G33602	G33602	19910218	0.00				1.16				1.07					1186	44.18
3319DD01602	G33602	G33602	19910425	0.00				1.23				0.00					808	0.33
3319DD01603	G33603	G33603	19900000	0.00	0.09	0.047	0.508+	4.33	0.026	0.65+	0.152+		9.5	1.744	0.035		3824	-0.16
3319DD01603	G33603	G33603	19900619	0.00	0.08<	0.038	0.600+	5.06	0.020<	0.02<	0.155+	0.00	9.6	1.853	0.031		3909	0.65
3319DD01603	G33603	G33603	19900724	0.05	0.08<	0.014	0.069	0.30	0.020<	0.02<	0.098+		10.4	0.374	0.051		3902	3.24
3319DD01603	G33603	G33603	19900900	0.00	0.12	0.035	0.490	4.80	0.020<	0.10	0.050		9.8	1.595	0.093		3788	-2.55
3319DD01603	G33603	G33603	19901200	0.00	0.08<	0.042	0.537+	4.03	0.020<	1.38^	0.025<		9.0	1.597	0.092		3589	2.56
3319DD01603	G33603	G33603	19910131	0.00	0.08<	0.034	0.564+	5.02	0.020<	0.02<	0.045		9.2	1.557	0.047		3855	-2.83
3319DD01603	G33603	G33603	19910228	0.00				4.60				3.30					3681	-1.49
3319DD01603	G33603	G33603	19910425	0.00				4.30				3.79					3627	-2.08
3319DD01605	G33605	G33605	19900619	0.00	0.08<	0.051	0.094	2.72	0.020<	0.76+	0.763+	0.00	1.2	0.988	0.024		1899	-0.15
3319DD01605	G33605	G33605	19900724	0.37	0.08<	0.028	0.059	1.15	0.020<	2.90^	1.989^		10.0	0.571	0.024		2434	1.74
3319DD01605	G33605	G33605	19901200	0.00	0.68^	0.142	0.222	1.81	0.020<	0.48+	0.495+		8.5	1.151	0.075		1675	0.77
3319DD01605	G33605	G33605	19910131	0.00	0.26+	0.105	0.245	2.01	0.020<	0.24+	0.262+		8.8	1.127	0.053		1719	-0.43
3319DD01605	G33605	G33605	19910228	0.00				13.44				7.12					10397^	-4.57
3319DD01605	G33605	G33605	19910415	0.00				13.69				4.83					10600^	-4.67
3319DD01606	G33606	G33606	19900619	0.00	0.08<	0.019	0.013<	1.22	0.020<	0.34+	0.050	0.00	0.3	0.190	0.038		748	0.19
3319DD01606	G33606	G33606	19900724	0.26	0.08<	0.023	0.065	0.97	0.020<	0.47+	0.150+		1.5	0.503	0.022		882	2.20
3319DD01606	G33606	G33606	19901200	0.00	0.14	0.066	0.035	1.35	0.020<	0.64+	0.025<		17.9	1.112	0.063		1035	-0.70

Site id	# on map	Sample #	Date	NO2-N mg/L	Al mg/L	Ba mg/L	B mg/L	Br mg/L	Cu mg/L	Fe mg/L	Mn mg/L	PO4 mg/L	Si mg/L	Sr mg/L	Zn mg/L	Temp. C	TDS () mg/L	Ion-ba t
3319DD01606	G33606	G33606	19910131	0.00	0.08<	0.055	0.055	1.43	0.020<	1.20^	0.060+		17.0	1.110	0.060		1035	-1.91
3319DD01606	G33606	G33606	19910228	0.00				2.89				1.85					1922	2.50
3319DD01606	G33606	G33606	19910425	0.00				2.80				1.28					1905	1.33
3319DD01607	G33607	G33607	19900619	0.00	0.08<	0.034	0.021	1.15	0.020<	0.04	0.169+	0.00	0.2	0.423	0.035		754	-0.08
3319DD01607	G33607	G33607	19900724	1.12	0.08<	0.004	0.398	5.54	0.020<	0.18+	0.100+		0.3	0.620	0.018		776	1.86
3319DD01607	G33607	G33607	19901200	0.00	0.08<	0.030	0.521+	5.92	0.020<	0.96+	0.193+		7.8	1.923	0.118		4080	-1.11
3319DD01607	G33607	G33607	19910131	0.00	0.08<	0.014	0.570+	8.33	0.020<	2.93^	0.202+		3.1	0.947	0.053		3772	0.33
3319DD01607	G33607	G33607	19910228	0.00				1.30				0.00					768	-0.59
3319DD01607	G33607	G33607	19910425	0.00				1.25				0.00					741	5.15
3319DD02572	G33572A	G33572A	19900620	0.00	0.08<	0.134	0.641+	5.30	0.020<	0.08	0.520+	0.00	6.6	1.322	0.143		3364	-0.04
3319DD02572	G33572A	G33572A	19900727	0.32	0.08<	0.000	0.838+	2.32	0.020<	0.02<	0.561+		7.8	0.253	0.040		3572	0.24
3319DD02572	G33572A	G33572A	19901200	0.00	0.08	0.135	0.605+	4.44	0.020<	0.52+	0.025<		6.2	1.328	0.107		3425	3.16
3319DD02572	G33572A	G33572A	19910131	5.59	0.08<	0.002<	0.013<		0.020<	0.02<	0.025<		0.1<	0.001<	0.005<		3234	6.85
3319DD02572	G33572A	G33572A	19910305	0.00				25.22				0.00					13905^	-5.10
3319DD02572	G33572A	G33572A	19910426	0.00				22.23				0.00					13744^	-7.46
3319DD02574	G33574A	G33574A	19900727	1.51	0.08<	0.222	1.632+	16.38	0.040	0.02<	0.025<		12.7	4.836	0.005<		5991	-6.92
3319DD02574	G33574A	G33574A	19900900	0.00	0.08<	0.109	0.749+	10.65	0.025	0.02<	0.025<		13.6	3.251	0.148		5999	-2.87
3319DD02574	G33574A	G33574A	19901000	0.00	0.08<	0.185	0.703+	8.07	0.020<	1.10^	0.025<		13.4	3.231	0.005<		6397	-4.36
3319DD02575	G33575A	G33575A	19900620	0.00	0.08<	0.016	0.642+	1.90	0.020<	0.03	0.025<	0.00	6.8	0.302	0.036		1272	1.16
3319DD02576	G33576A	G33576A	19900620	0.00	0.08<	0.049	0.443	3.40	0.020<	0.08	0.025<	0.00	6.2	0.856	0.049		1383	35.06
3319DD02576	G33576A	G33576A	19900727	0.00	0.08<	0.419	0.046	6.40	0.020<	0.14+	0.025<		7.5	2.022	0.026		2124	1.31
3319DD02576	G33576A	G33576A	19900900	0.00	0.08<	0.054	0.395	4.39	0.020<	0.28+	0.025<		6.7	0.829	0.043		2079	-1.52
3319DD02576	G33576A	G33576A	19901000	0.00	0.08<	0.047	0.432	3.48	0.020<	0.49+	0.025<		6.5	0.851	0.025		2331	-2.39
3319DD02576	G33576A	G33576A	19910131	0.00	0.08<	0.044	0.445	3.50	0.020<	0.79+	0.025<		6.4	0.902	0.032		2150	-0.39
3319DD02584	G33584A	G33584A	19900620	0.00	0.08<	0.030	1.148+	5.90	0.020<	0.08	0.032	0.00	6.7	1.018	0.062		3697	-2.50
3319DD02584	G33584A	G33584A	19900727	2.39	0.08<	0.002<	1.988+	11.79	0.096	0.16+	0.025<		7.7	0.470	0.048		3861	6.14
3319DD02584	G33584A	G33584A	19901200	0.00	0.08<	0.032	0.967+	21.86	0.020<	0.54+	0.025<		0.1<	6.852	0.143		13829^	-3.96
3319DD02584	G33584A	G33584A	19910131	0.00	0.08<	0.034	0.990+	5.82	0.020<	0.10	0.025<		6.4	1.045	0.064		4186	-5.59
3319DD02584	G33584A	G33584A	19910325	0.00				6.44				0.00					3686	2.43
3319DD02584	G33584A	G33584A	19910426	0.20	6.50^			0.00				0.00					4600	-13.40
3319DD02585	G33585A	G33585A	19900620	0.00	0.08<	0.047	3.834^	22.40	0.026	0.02<	0.025<	0.00	6.4	6.794	0.005<		14128^	0.64
3319DD02585	G33585A	G33585A	19900727	0.43	0.08<	0.108	0.644+	3.68	0.023	0.02<	0.071+		5.8	1.756	0.157		15184^	-1.16
3319DD02585	G33585A	G33585A	19900900	0.00	0.08<	0.002<	0.135	26.75	0.020<	0.02<	0.025<		0.2	0.308	0.008		8713	-90.58
3319DD02585	G33585A	G33585A	19901000	0.00	0.08<	0.062	3.162^	21.40	0.020<	2.18^	0.025<		5.9	6.487	0.005<		15422^	-3.95
3319DD02585	G33585A	G33585A	19901200	0.00	0.08<	0.035	3.364^		0.020<	0.50+	0.025<		5.6	6.798	0.296		15087^	-2.77
3319DD02585	G33585A	G33585A	19910131	0.00	0.08<	0.042	3.344^	23.90	0.127	0.02<	0.025<		5.9	6.321	0.056		14361^	-0.66
3319DD02585	G33585A	G33585A	19910305	0.00				31.02				10.72					14985^	-0.72
3319DD02585	G33585A	G33585A	19910426	0.00				29.26				9.90					14672^	-7.59
3319DD02591	G33591A	G33591A	19900620	0.00	0.08<	0.039	0.259	1.20	0.020<	0.12+	0.025<	0.00	6.6	0.600	0.033		934	1.40
3319DD02591	G33591A	G33591A	19900700	0.29	0.08<	0.032	0.591+	1.95	0.020<	0.18+	0.730+		10.0	0.910	0.033		1921	1.71
3319DD02591	G33591A	G33591A	19910405	0.00				7.31				0.00					4225	-2.06
3319DD03591	G33591B	G33591B	19900620	0.00	0.08<	0.058	0.969+	7.80	0.020<	0.02<	0.063+	0.00	6.5	1.936	0.030		4290	-0.95
3319DD03591	G33591B	G33591B	19900727	0.71	0.08<	0.055	0.487	2.81	0.020<	0.02<	0.025<		8.0	1.271	0.044		4648	0.63
3319DD03591	G33591B	G33591B	19900900	0.00	0.08<	0.055	0.773+	7.22	0.020<	0.02<	0.025<		6.6	1.816	0.032		4523	-4.10
3319DD03591	G33591B	G33591B	19901000	0.00	0.08<	0.053	0.873+	0.57	0.020<	0.12+	0.025<		6.8	1.848	0.009		2528	67.71
3319DD03591	G33591B	G33591B	19901200	0.00	0.08<	0.007	0.120	1.13	0.020<	0.34+	0.025<		0.1	0.299	0.076		743	-7.03
3319DD03591	G33591B	G33591B	19910131	0.00	0.08<	0.053	0.845+	51.39	0.020<	0.02<	0.025<		6.5	1.890	0.025		4675	-2.24
3319DD03591	G33591B	G33591B	19910305	0.00				6.14				1.72					3629	-2.01

Site id	# on map	Sample #	Date	NO2-N mg/L	Al mg/L	Ba mg/L	B mg/L	Br mg/L	Cu mg/L	Fe mg/L	Mn mg/L	PO4 mg/L	Si mg/L	Sr mg/L	Zn mg/L	Temp. C	TDS () mg/L	Ion-ba l
3319DD03591	G33591B	G33591B	19910426	0.00				5.90				2.02					3639	1.24
3319DD04574	G33574C	G33574C	19900620	0.00	0.08<	0.390	1.060+	1.60	0.020<	0.02<	0.025<	0.00	10.4	2.210	0.027		4509	-2.92
3319DD04574	G33574C	G33574C	19900727	1.19	0.08<	0.317	1.056+	6.30	0.020<	0.02<	0.042		13.4	3.061	0.006		3947	-41.22
3319DD04574	G33574C	G33574C	19900900	0.00	0.08<	0.363	0.748+	7.83	0.020<	0.07	0.025<		12.0	2.195	0.011		4607	-2.77
3319DD04574	G33574C	G33574C	19901000	0.00	0.08<	0.367	0.861+	6.58	0.044	0.43+	0.025<		14.8	2.290	0.005<		4980	-4.77
3319DD04574	G33574C	G33574C	19901220	0.00	0.08<	0.052	0.418	7.37	0.020<	0.31+	0.025<		6.0	0.915	0.048		3624	-34.60
3319DD04574	G33574C	G33574C	19910131	0.00	0.08<	0.423	0.941+	7.03	0.020<	0.02<	0.144+		11.0	2.186	0.033		4560	-1.58
3319DD04574	G33574C	G33574C	19910305	0.00				7.00				4.30					3630	-0.37
3319DD04574	G33574C	G33574C	19910426	0.00				6.49				1.26					3708	2.87
3320CC00101	H5M04		19871005										1.8			11.6	182	1.02
3320CC00101	H5M04		19871012										1.7			20.0	275	3.59
3320CC00101	H5M04		19871019										1.7			15.0	305	3.55
3320CC00101	H5M04		19871026										1.7			15.0	366	1.01
3320CC00101	H5M04		19871102										0.9			0.0	496	1.58
3320CC00101	H5M04		19871109										0.9			0.0	381	2.03
3320CC00101	H5M04		19871116										1.0			25.0	525	2.10
3320CC00101	H5M04		19871123										1.0			22.0	393	2.05
3320CC00101	H5M04		19871130										1.4			27.0+	611	2.10
3320CC00101	H5M04		19871207										1.1			26.0+	630	1.47
3320CC00101	H5M04		19871214										1.6			20.0	120	0.52
3320CC00101	H5M04		19871221										1.4			28.0+	323	1.14
3320CC00101	H5M04		19871228										1.6			26.0+	415	1.55
3320CC00101	H5M04		19880104										1.0			26.0+	413	0.60
3320CC00101	H5M04		19880111										1.0			29.0+	525	0.53
3320CC00101	H5M04		19880118										0.8			27.0+	618	1.83
3320CC00101	H5M04		19880125										0.3			26.0+	1143	-0.40
3320CC00101	H5M04		19880201										0.2			27.0+	366	2.34
3320CC00101	H5M04		19880208										0.6			28.0+	1157	1.58
3320CC00101	H5M04		19880215										0.9			27.0+	364	1.09
3320CC00101	H5M04		19880222										1.5			27.0+	862	2.73
3320CC00101	H5M04		19880229										0.9			28.0+	1147	0.43
3320CC00101	H5M04		19880307										1.1			21.6	903	0.88
3320CC00101	H5M04		19880314										6.6			24.0	1230	0.84
3320CC00101	H5M04		19880321										2.2			20.0	1386	0.58
3320CC00101	H5M04		19880328										1.1			24.0	1545	1.14
3320CC00101	H5M04		19880404										1.7			25.0	954	-2.49
3320CC00101	H5M04		19880411										1.0			20.0	388	0.56
3320CC00101	H5M04		19880418										1.3			20.7	560	1.05
3320CC00101	H5M04		19880502										2.0			21.0	202	-0.78
3320CC00101	H5M04		19880509										2.3			12.0	376	-0.17
3320CC00101	H5M04		19880516										1.8			17.4	631	2.82
3320CC00101	H5M04		19880523										1.2			14.6	75	10.40
3320CC00101	H5M04		19880530										1.2			12.6	62	10.34
3320CC00101	H5M04		19880606										0.9			13.0	45	0.73
3320CC00101	H5M04		19880613										1.8			13.0	107	1.46
3320CC00101	H5M04		19880620										1.8			11.0	133	-0.48
3320CC00101	H5M04		19880627										2.0			12.2	196	0.48
3320CC00101	H5M04		19880704										2.2			13.5	294	0.11

Site id	# on map	Sample #	Date	NO2-N mg/L	Al mg/L	Ba mg/L	B mg/L	Br mg/L	Cu mg/L	Fe mg/L	Mn mg/L	PO4 mg/L	Si mg/L	Sr mg/L	Zn mg/L	Temp. C	TDS () mg/L	Ion-ba %
3320CC00101	H5M04		19880711										1.1			10.2	52	-2.53
3320CC00101	H5M04		19880718										1.7			12.0	162	-2.94
3320CC00101	H5M04		19880725										1.2			11.5	88	-1.78
3320CC00101	H5M04		19880801										1.8			11.6	240	1.82
3320CC00101	H5M04		19880808										1.9			13.8	330	2.30
3320CC00101	H5M04		19880815										1.4			15.0	181	0.86
3320CC00101	H5M04		19880822										1.6			12.4	404	-0.46
3320CC00101	H5M04		19880829										1.8			14.0	306	-0.45
3320CC00101	H5M04		19880905										2.0			14.8	95	4.55
3320CC00101	H5M04		19880912										1.7			13.7	84	-3.01
3320CC00101	H5M04		19880919										1.3			13.0	65	-0.48
3320CC00101	H5M04		19880926										1.2			18.2	157	
3320CC00101	H5M04		19881003										1.4			18.0	116	2.92
3320CC00101	H5M04		19881010										1.7			18.5	236	-1.32
3320CC00101	H5M04		19881017										1.6			20.0	325	-2.41
3320CC00101	H5M04		19881024										1.5			23.0	576	-0.81
3320CC00101	H5M04		19881025			0.041							1.0	0.266			451	2.38
3320CC00101	H5M04		19881107										1.0			25.0	310	0.90
3320CC00101	H5M04		19881114										1.1			26.2+	641	-0.95
3320CC00101	H5M04		19881121										0.5			28.0+	494	-0.50
3320CC00101	H5M04		19881128										0.4			25.0	551	-0.28
3320CC00101	H5M04		19881205										1.2			20.0	797	-1.94
3320CC00101	H5M04		19881212										1.0			23.6	1023	0.33
3320CC00101	H5M04		19881219										1.0			24.2	592	0.83
3320CC00101	H5M04		19881226										0.7			28.0+	655	1.65
3320CC00101	H5M04		19890102										1.2			28.0+	578	0.27
3320CC00101	H5M04		19890109										0.9			26.0+	583	0.21
3320CC00101	H5M04		19890116										1.2			26.5+	707	-0.39
3320CC00101	H5M04		19890123										1.2			25.8+	556	0.55
3320CC00101	H5M04		19890130										1.2			27.0+	510	-0.66
3320CC00101	H5M04		19890206										0.8			25.0	642	-1.40
3320CC00101	H5M04		19890213										1.1			24.0	634	-1.81
3320CC00101	H5M04		19890220										1.0			27.0+	1384	-0.51
3320CC00101	H5M04		19890227										2.8			26.0+	1631	1.26
3320CC00101	H5M04		19890306										0.6			0.0	273	1.23
3320CC00101	H5M04		19890313										1.4			23.0	837	-0.70
3320CC00101	H5M04		19890320										2.0			22.0	264	-1.79
3320CC00101	H5M04		19890327										2.7			25.4+	736	-0.17
3320CC00101	H5M04		19890403										1.7			19.0	77	4.80
3320CC00101	H5M04		19890410										2.0			22.0	457	0.14
3320CC00101	H5M04		19890417										1.8			20.4	540	2.05
3320CC00101	H5M04		19890424										2.4			18.2	244	3.57
3320CC00101	H5M04		19890426			0.004<						0.03	2.7	0.188			267	-0.74
3320CC00101	H5M04		19890501										2.7			19.0	440	-0.57
3320CC00101	H5M04		19890508										2.5			18.5	506	-0.18
3320CC00101	H5M04		19890515										1.2			13.1	74	-0.85
3320CC00101	H5M04		19890522										2.3			15.5	201	-2.22
3320CC00101	H5M04		19890529										1.8			14.8	265	1.75

Site id	# on map	Sample #	Date	NO2-N mg/L	Al mg/L	Ba mg/L	B mg/L	Br mg/L	Cu mg/L	Fe mg/L	Mn mg/L	PO4 mg/L	Si mg/L	Sr mg/L	Zn mg/L	Temp. C	TDS () mg/L	Ion-ba l
3320CC00101	H5M04		19890605										1.5			12.3	91	-3.50
3320CC00101	H5M04		19890612										1.8			11.5	257	-0.61
3320CC00101	H5M04		19890619										5.7			0.0	382	0.66
3320CC00101	H5M04		19890626										5.9			13.0	293	-0.11
3320CC00101	H5M04		19890703										1.6			12.2	139	-2.06
3320CC00101	H5M04		19890710										1.8			11.4	144	-2.46
3320CC00101	H5M04		19890717										1.6			12.8	176	0.71
3320CC00101	H5M04		19890724										1.7			10.8	164	-1.55
3320CC00101	H5M04		19890731										1.5			12.1	166	0.30
3320CC00101	H5M04		19890814										1.9			14.0	231	-0.67
3320CC00101	H5M04		19890821										1.3			14.2	109	-3.23
3320CC00101	H5M04		19890828										1.4			14.1	135	-3.53
3320CC00101	H5M04		19890904										1.4			13.1	118	1.32
3320CC00101	H5M04		19890907										1.6			13.6	158	-1.39
3320CC00101	H5M04		19890911										7.5			16.3	128	-2.84
3320CC00101	H5M04		19890918										6.7			15.6	212	-0.60
3320CC00101	H5M04		19890925										7.2			16.4	121	-3.33
3320CC00101	H5M04	H5M04	19900608	0.00	0.14	0.011	0.013<	0.02	0.020<	0.28+	0.025<	0.00	1.7	0.048	0.044		97	1.64
3320CC00101	H5M04	H5M04	19900621	0.00	0.08<	0.019	0.023	0.28	0.020<	0.29+	0.025<	0.00	2.5	0.168	0.028		361	2.93
3320CC00101	H5M04	H5M04	19900723	0.19	0.08<	0.031	0.239	1.44	0.020<	0.28+	0.025<		2.7	0.870	0.023		237	4.62
3320CC00101	H5M04	H5M04	19900900	0.00	0.08<	0.017	0.072	0.26	0.020<	0.15+	0.025<		1.2	0.165	0.035		373	-2.64
3320CC00101	H5M04	H5M04	19900906	2.76	0.08<	0.053	0.266	13.98	0.064	0.36+	0.025<		1.5	3.030	0.128		305	-0.83
3320CC00101	H5M04	H5M04	19901025	0.00	0.08<	0.024	0.117	0.73	0.020<	0.20+	0.025<		0.9	0.276	0.023		632	-5.02
3320CC00101	H5M04	H5M04	19901130	0.00	0.08<	0.032	0.239	1.36	0.020<	0.67+	0.025<		1.2	0.459	0.038	20.0	1071	-3.44
3320CC00101	H5M04	H5M04	19901206	0.00	0.08<	0.024	0.200	0.94	0.020<	0.34+	0.045		1.4	0.394	0.017		1003	2.09
3320CC00101	H5M04	H5M04	19901218	0.00	0.08<	0.036	0.228	0.18	0.020<	0.24+	0.030		1.4	0.417	0.049	22.5	134	2.11
3320CC00101	H5M04	H5M04	19910122	0.00	0.08<	0.026	0.179	0.87	0.020<	0.06	0.025<		0.2	0.312	0.110	26.1+	676	1.14
3320CC00101	H5M04	H5M04	19910212	0.00	0.11	0.069	0.417	2.26	0.033	1.72^	0.134+		1.0	0.775	0.049		1867	4.15
3320CC00101	H5M04	H5M04	19910301	0.00	0.08<	0.059	0.410	2.27	0.020<	0.15+	0.025<		1.2	0.757	0.028		1925	0.49
3320CC00101	H5M04	H5M04	19910319	0.00				0.93				0.00					865	5.20
3320CC00101	H5M04	H5M04	19910423	0.00				1.52				0.00					1501	-0.12
3320CC00102	H3M11		19871005										1.6			18.0	885	1.29
3320CC00102	H3M11		19871012										2.2			18.0	1176	-1.29
3320CC00102	H3M11		19871019										4.0			14.0	2447	0.18
3320CC00102	H3M11		19871027										3.8			17.0	2810	-0.49
3320CC00102	H3M11		19871102										3.2				1796	0.03
3320CC00102	H3M11		19871109										4.0				2363	-0.56
3320CC00102	H3M11		19871116										3.8			21.0	2343	0.09
3320CC00102	H3M11		19871123										3.1			24.0	1681	0.73
3320CC00102	H3M11		19871130										5.9			24.0	2994	-1.67
3320CC00102	H3M11		19871207										5.7			26.0+	2696	-0.59
3320CC00102	H3M11		19871214										4.8			26.0+	2938	-1.35
3320CC00102	H3M11		19871221										4.2			29.0+	3197	-1.29
3320CC00102	H3M11		19871228										2.7			26.0+	1596	-1.04
3320CC00102	H3M11		19880104										3.6			27.0+	1774	0.50
3320CC00102	H3M11		19880111										4.8			27.0+	2968	-0.01
3320CC00102	H3M11		19880118										5.6			27.0+	3260	-0.26
3320CC00102	H3M11		19880125										4.5			27.0+	2786	0.08

Site id	# on map	Sample #	Date	NO2-N mg/L	Al mg/L	Ba mg/L	B mg/L	Br mg/L	Cu mg/L	Fe mg/L	Mn mg/L	PO4 mg/L	Si mg/L	Sr mg/L	Zn mg/L	Temp. C	TDS () mg/L	Ion-ba %
3320CC00102	H3M11		19880201										5.5			28.0+	2780	-0.39
3320CC00102	H3M11		19880208										7.4			28.0+	2967	-0.32
3320CC00102	H3M11		19880215										9.3			27.0+	2574	0.90
3320CC00102	H3M11		19880222										4.1			29.0+	1620	-0.45
3320CC00102	H3M11		19880229										3.7			26.0+	1498	-0.78
3320CC00102	H3M11		19880307										5.8			23.6	1931	2.62
3320CC00102	H3M11		19880314										9.6			23.0	1975	0.57
3320CC00102	H3M11		19880321										7.6				2762	0.51
3320CC00102	H3M11		19880328										7.1			24.6	2925	0.15
3320CC00102	H3M11		19880404										8.7			20.0	2797	1.97
3320CC00102	H3M11		19880411										6.7			21.0	2357	0.72
3320CC00102	H3M11		19880418										8.2			21.5	3025	0.72
3320CC00102	H3M11		19880425										6.5			15.5	2165	-0.04
3320CC00102	H3M11		19880502										4.6			21.0	1290	2.56
3320CC00102	H3M11		19880509										6.3			12.0	2763	-0.29
3320CC00102	H3M11		19880516										6.1			16.8	2967	1.74
3320CC00102	H3M11		19880523										7.1			13.5	3050	-0.07
3320CC00102	H3M11		19880530										6.5			14.0	2795	1.84
3320CC00102	H3M11		19880606										6.2			13.0	2506	2.12
3320CC00102	H3M11		19880613										4.5			12.0	1575	1.71
3320CC00102	H3M11		19880620										4.5			11.0	2243	0.82
3320CC00102	H3M11		19880627										3.7			11.6	2150	0.33
3320CC00102	H3M11		19880704										2.9			12.0	1973	-0.60
3320CC00102	H3M11		19880711										1.8			10.6	1638	-0.32
3320CC00102	H3M11		19880718										2.1			11.8	1234	-0.43
3320CC00102	H3M11		19880725										1.8			12.0	1369	0.29
3320CC00102	H3M11		19880801										2.8			12.6	2006	-1.51
3320CC00102	H3M11		19880808										2.8			14.4	2717	-0.10
3320CC00102	H3M11		19880815										1.4			15.0	1623	-2.85
3320CC00102	H3M11		19880822										1.9			11.8	1719	-2.38
3320CC00102	H3M11		19880829										4.2			14.0	1746	-2.10
3320CC00102	H3M11		19880905										1.3			17.0	831	-0.86
3320CC00102	H3M11		19880912										1.3			13.5	1302	-2.25
3320CC00102	H3M11		19880919										1.4			12.0	1044	-0.69
3320CC00102	H3M11		19880926										1.9			16.5	1590	-1.47
3320CC00102	H3M11		19881003										2.3			19.5	2748	-1.07
3320CC00102	H3M11		19881010										2.9			16.5	2278	-1.13
3320CC00102	H3M11		19881017										1.5			17.0	932	1.09
3320CC00102	H3M11		19881024										2.2			19.0	1712	-0.65
3320CC00102	H3M11		19881025			0.097							1.7	0.883			1571	
3320CC00102	H3M11		19881031										2.7			19.0	2070	-0.42
3320CC00102	H3M11		19881107										3.4			25.0	2678	-0.15
3320CC00102	H3M11		19881114										3.7			23.5	2369	-0.47
3320CC00102	H3M11		19881121										4.7			25.0	2513	-0.16
3320CC00102	H3M11		19881128										5.5			22.0	2985	0.71
3320CC00102	H3M11		19881205										5.6			20.0	3337	0.43
3320CC00102	H3M11		19881212										4.6			20.5	3407	0.24
3320CC00102	H3M11		19881219										4.3			22.4	2188	0.67

Site id	# on map	Sample #	Date	NO2-N mg/L	Al mg/L	Ba mg/L	B mg/L	Br mg/L	Cu mg/L	Fe mg/L	Mn mg/L	PO4 mg/L	Si mg/L	Sr mg/L	Zn mg/L	Temp. C	TDS () mg/L	Ion-ba l
3320CC00102	H3M11		19890102										5.4			25.2+	1520	0.31
3320CC00102	H3M11		19890109										7.7			27.0+	3138	-0.31
3320CC00102	H3M11		19890116										7.3			26.5+	3097	-0.34
3320CC00102	H3M11		19890123										7.2			26.0+	3286	0.13
3320CC00102	H3M11		19890130										9.7			30.0+	3400	-1.01
3320CC00102	H3M11		19890206										7.1			28.0+	3519	-0.68
3320CC00102	H3M11		19890213										6.5			23.2	2450	-0.12
3320CC00102	H3M11		19890220										8.1			27.0+	3212	0.11
3320CC00102	H3M11		19890227										9.4			28.0+	2956	0.89
3320CC00102	H3M11		19890306										6.9			25.0	2137	-0.01
3320CC00102	H3M11		19890313										7.9			20.6	2721	-0.46
3320CC00102	H3M11		19890320										7.3			23.6	2026	-1.38
3320CC00102	H3M11		19890327										4.9			24.6	991	0.38
3320CC00102	H3M11		19890403										4.3			20.0	1225	-0.96
3320CC00102	H3M11		19890410										4.6			21.6	1264	-1.65
3320CC00102	H3M11		19890417										5.7			20.6	1754	-0.49
3320CC00102	H3M11		19890424										6.1			18.5	890	0.85
3320CC00102	H3M11		19890426			0.004<						0.13	6.3	0.503			1195	2.15
3320CC00102	H3M11		19890501										5.0			18.0	1470	-0.44
3320CC00102	H3M11		19890508										5.6			18.0	2149	1.23
3320CC00102	H3M11		19890515										5.4			13.2	1989	-1.57
3320CC00102	H3M11		19890522										6.7			17.4	2846	-1.08
3320CC00102	H3M11		19890529										7.4			13.7	2960	-0.66
3320CC00102	H3M11		19890605										7.3			14.9	3082	-0.80
3320CC00102	H3M11		19890612										4.8			10.1	1944	1.60
3320CC00102	H3M11		19890619										5.5			14.6	2670	-0.99
3320CC00102	H3M11		19890626										4.3			13.0	1244	1.30
3320CC00102	H3M11		19890703										3.7			12.0	1491	-0.31
3320CC00102	H3M11		19890710										4.0			12.0	1957	0.18
3320CC00102	H3M11		19890717										2.2			12.2	1327	-0.09
3320CC00102	H3M11		19890724										1.5			11.4	1360	-0.16
3320CC00102	H3M11		19890731										1.4			12.7	1205	-1.29
3320CC00102	H3M11		19890807										2.0			13.7	1150	1.69
3320CC00102	H3M11		19890814										3.0			14.5	1202	0.00
3320CC00102	H3M11		19890821										1.7			14.5	1213	-1.64
3320CC00102	H3M11		19890828										1.9			15.2	1278	0.81
3320CC00102	H3M11		19890904										1.8			13.5	1124	0.55
3320CC00102	H3M11	H3M11	19900608	0.00	0.08<	0.058	0.292	1.91	0.020<	0.08	0.034	0.00	5.2	0.839	0.018		1735	-3.28
3320CC00102	H3M11	H3M11	19900621	0.00	0.08<	0.054	0.295	2.06	0.020<	0.03	0.026	0.00	5.2	0.854	0.038		1845	0.25
3320CC00102	H3M11	H3M11	19900723	0.13	0.08<	0.021	0.152	0.86	0.020<	0.02	0.025<		1.6	0.511	0.013		1494	0.12
3320CC00102	H3M11	H3M11	19900906	0.03	0.08<	0.015	0.013<	0.30	0.020<	0.11+	0.025<		3.4	0.201	0.021		1652	-0.39
3320CC00102	H3M11	H3M11	19900925	0.00	0.08<	0.050	0.356	2.21	0.020<	0.14+	0.025<		2.9	0.909	0.030		2152	-3.08
3320CC00102	H3M11	H3M11	19901025	0.00	0.08<	0.079	0.505+	3.70	0.020<	0.21+	0.025<		4.9	1.247	0.005<		3090	-3.99
3320CC00102	H3M11	H3M11	19901130	0.00	0.08<	0.066	0.513+	3.04	0.020<	0.07	0.115+		5.0	1.060	0.020	20.0	2558	-2.11
3320CC00102	H3M11	H3M11	19901206	0.00	0.08<	0.066	0.428	2.37	0.020<	0.31+	0.073+		4.9	0.880	0.041		2182	-1.23
3320CC00102	H3M11	H3M11	19901218	0.00	0.08<	0.060	0.403	2.53	0.020<	0.11+	0.030		5.0	0.858	0.052	18.8	1955	-0.33
3320CC00102	H3M11	H3M11	19910122	0.00	0.08<	0.093	0.658+	4.00	0.020<	0.03	0.025<		6.5	1.362	0.085	22.6	3198	-0.68
3320CC00102	H3M11	H3M11	19910212	0.00	0.08<	0.082	0.483	3.12	0.033	0.73+	0.386+		5.0	0.894	0.046		2176	0.88

Site id	# on map	Sample #	Date	NO2-N mg/L	Al mg/L	Ba mg/L	B mg/L	Br mg/L	Cu mg/L	Fe mg/L	Mn mg/L	PO4 mg/L	Si mg/L	Sr mg/L	Zn mg/L	Temp. C	TDS () mg/L	Ion-ba %
3320CC00102	H3M11	H3M11	19910301	0.00	0.08<	0.083	0.561+	3.05	0.020<	0.45+	0.025		6.6	1.077	0.028		2708	-0.41
3320CC00102	H3M11	H3M11	19910319	0.00				2.66				1.54					2347	1.05
3320CC00102	H3M11	H3M11	19910423	0.00				0.00				0.00					2758	-1.60

Selected standard : SA drinking water- humans

^ * Exceeds max acceptable value - = Below min guideline value
 + = Exceeds max guideline value v = Below min acceptable value
 < = Below detection limit

Appendix 7

Hydrochemical graphs: Malmesbury Group

 * HydroBase * User Defined Report * Date printed : 28 October 1991
 Generated for : Breede River Project
 Date range : 19000101 to 19991231 * Site range : Malmesbury Group

 Data from file BASICINF :

SITE_ID_NR	NR_ON_MAP	SITE_NAME	SITE_TYPE	DEPTH
3319DA00002	NG01	KLOPPERSBOSCH - NAUDES BERG	Borehole	152.00
3319DA00003	NG02	NAUDES BERG - KLOPPERSBOSCH	Borehole	152.40
3319DA00004	NG03	NAUDES BERG - KLOPPERSBOSCH	Borehole	83.80
3319DA00008	VR01	VINKRIVIER - AMANDALIA	Borehole	152.00
3319DB00016	NE08	BLUITENSTEKLOOF	Borehole	31.00
3319DD00045	DP04	DE HOOP - KEURKLOOF	Borehole	91.00
3319DD00047	DP06	DE HOOP	Borehole	85.00
3319DD00049	DP08	DE HOOP	Borehole	145.00
3319DD00050	DP09	DE HOOP, Mon Desir, Mr. Burger	Borehole	54.86
3319DD00051	RE01	DE HOOP, Croxley, above vineyard	Borehole	232.00
3319DB00005	KD01	KRUISPAD	Borehole	61.00
3319DB00007	KD03	KRUISPAD	Borehole	61.00
3319DB00011	NE03	NOREE, Volkshuis pomp	Borehole	46.00
3319DB00012	NE02	NOREE, Huispomp	Borehole	64.00
3319DB00013	NE01	NOREE, Appelkoosboort	Borehole	94.00

Malmesbury

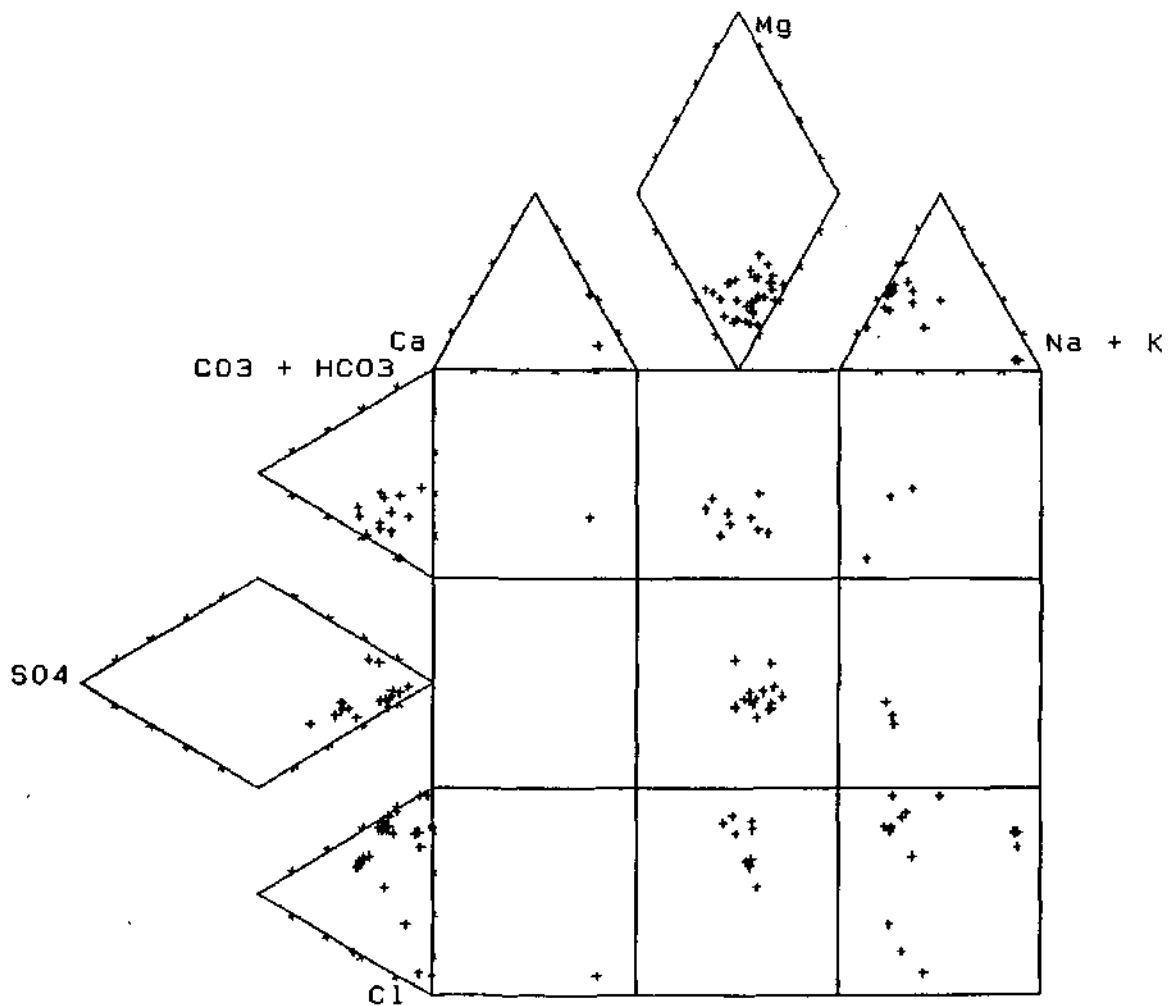

* HydroBase * EXPANDED DUROV DIAGRAM *
Generated for : Breede River Project

DATE PLOTTED: Oct 28 1991

Malmesbury

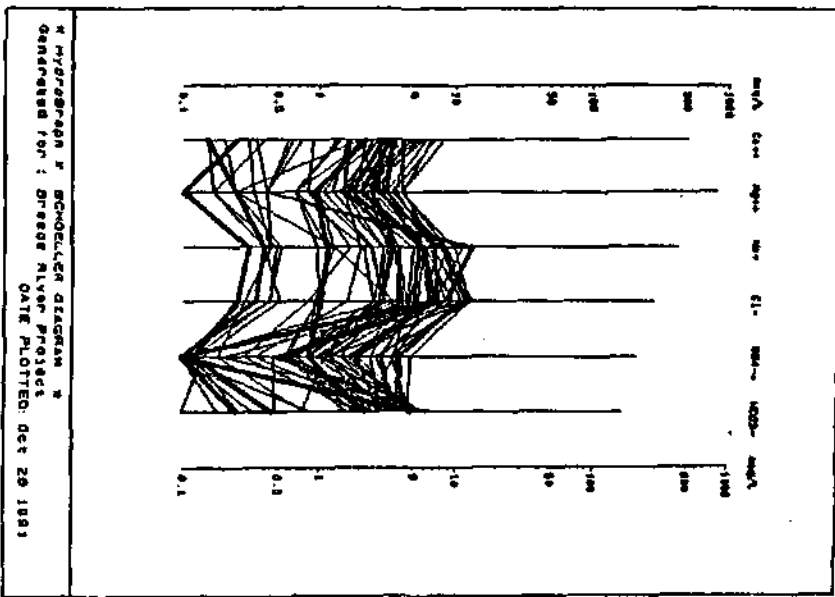
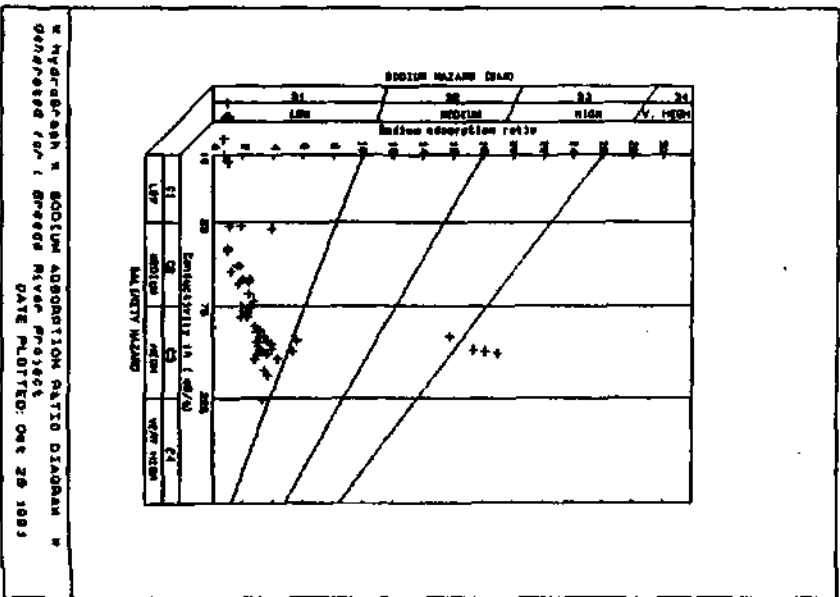
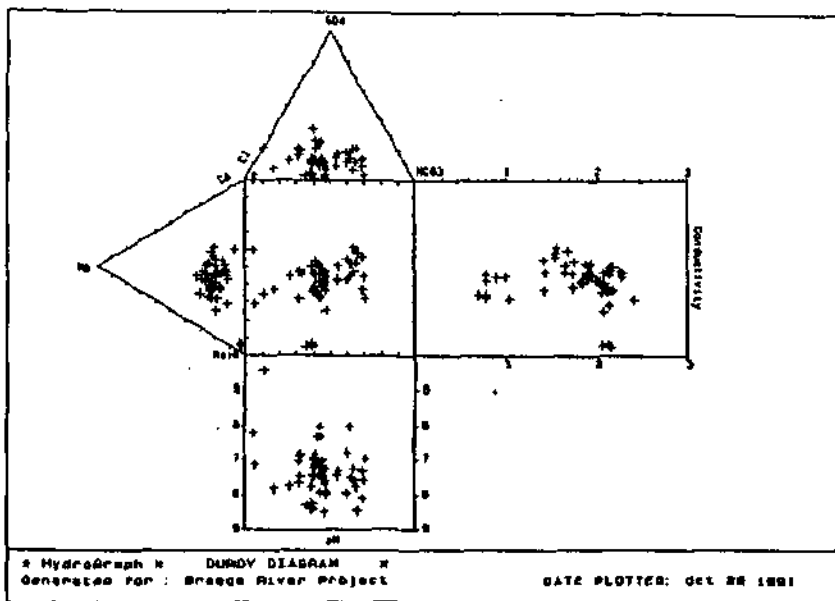
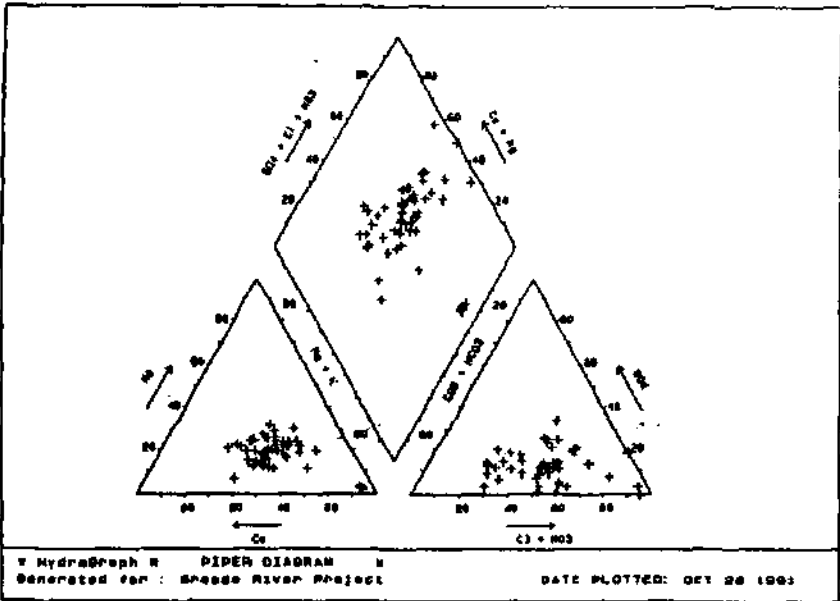

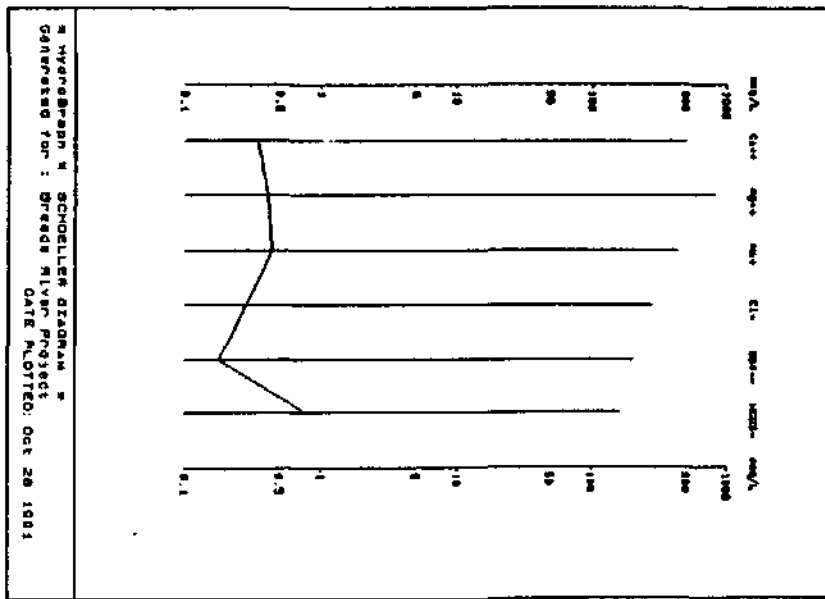
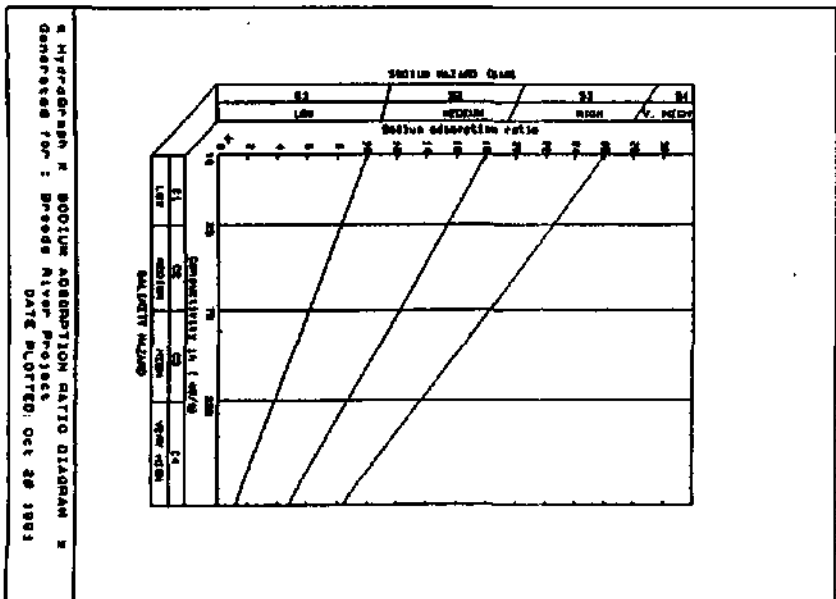
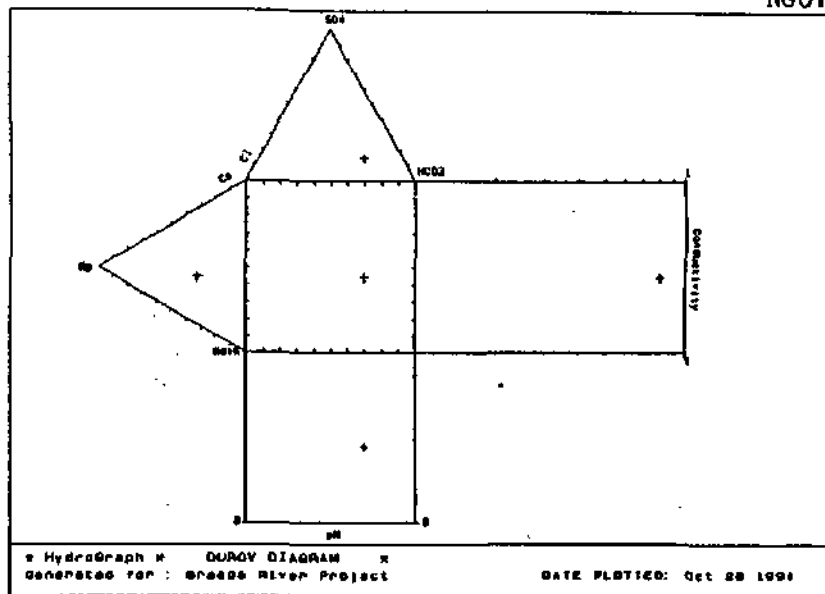
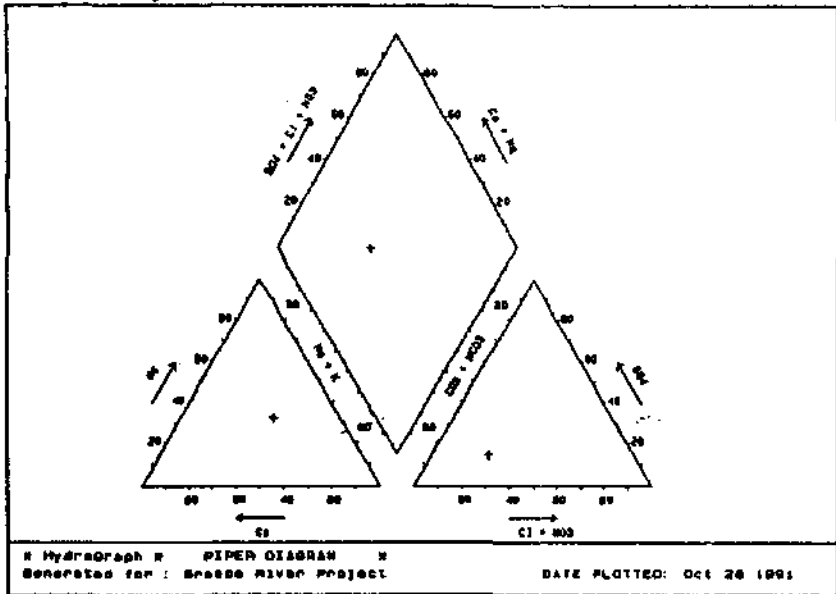

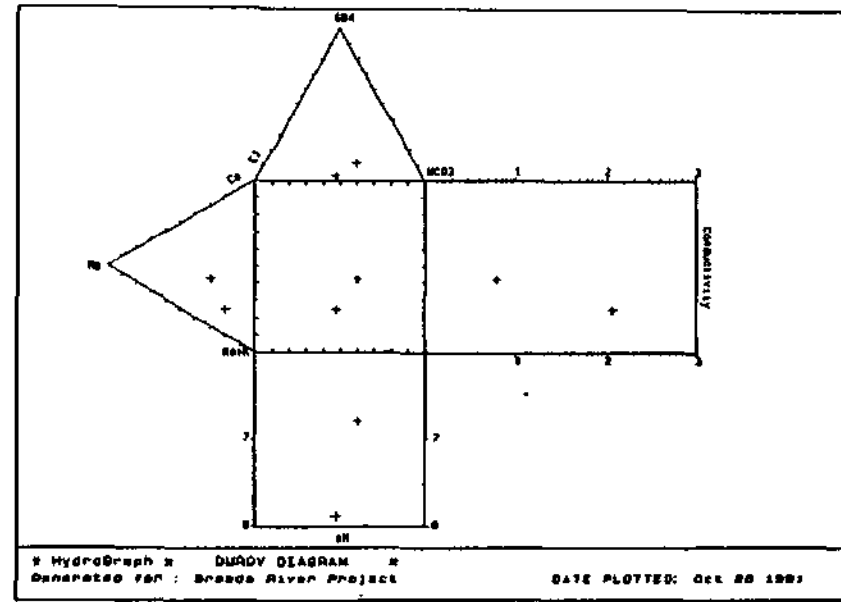
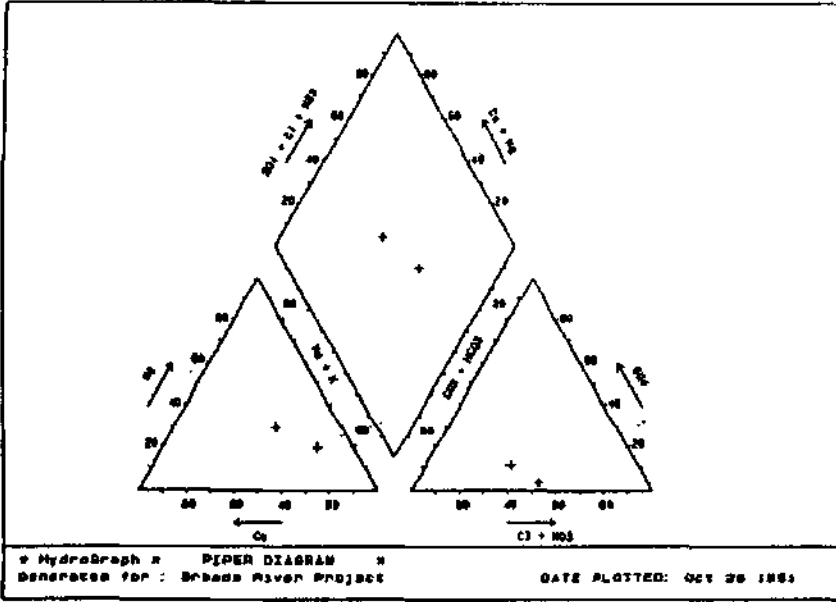

203

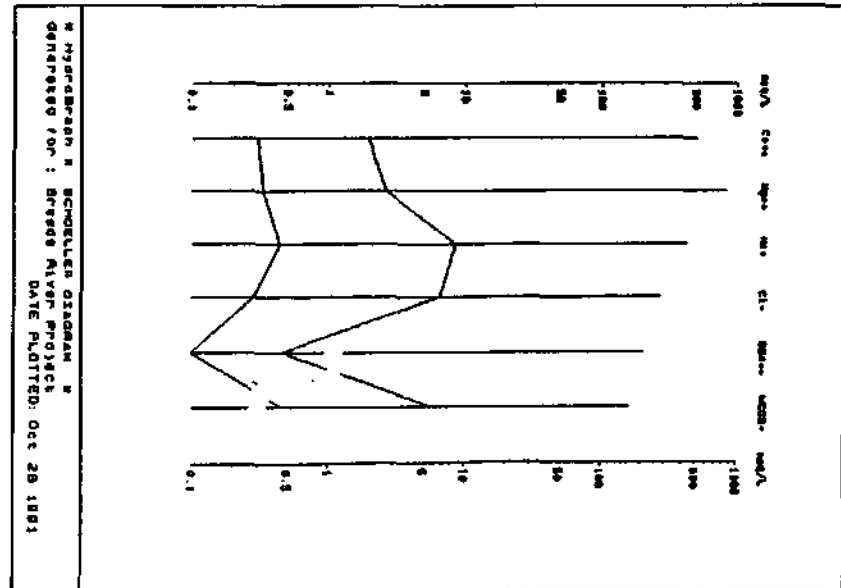
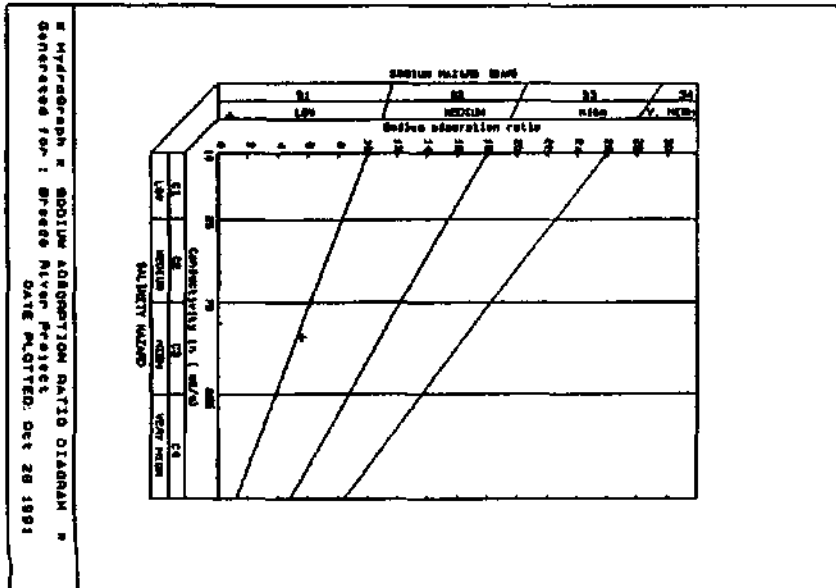

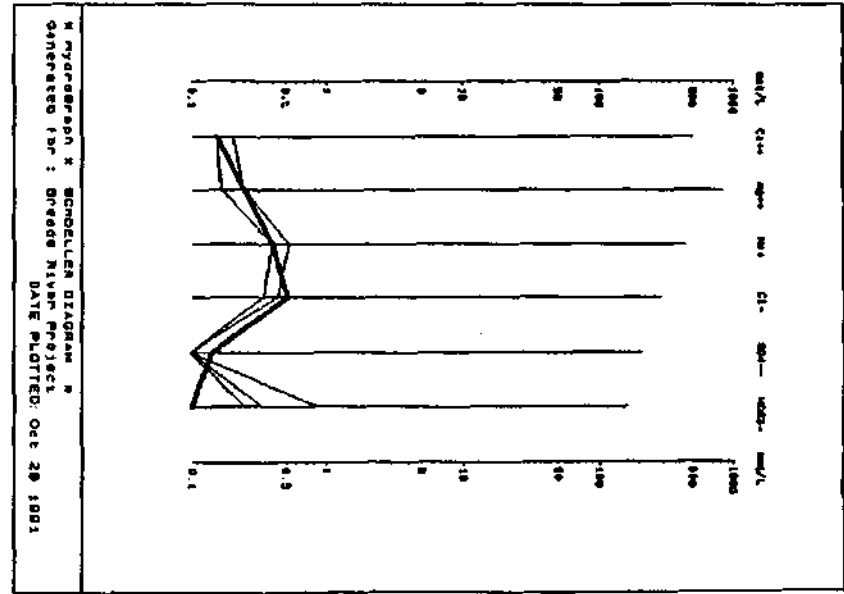
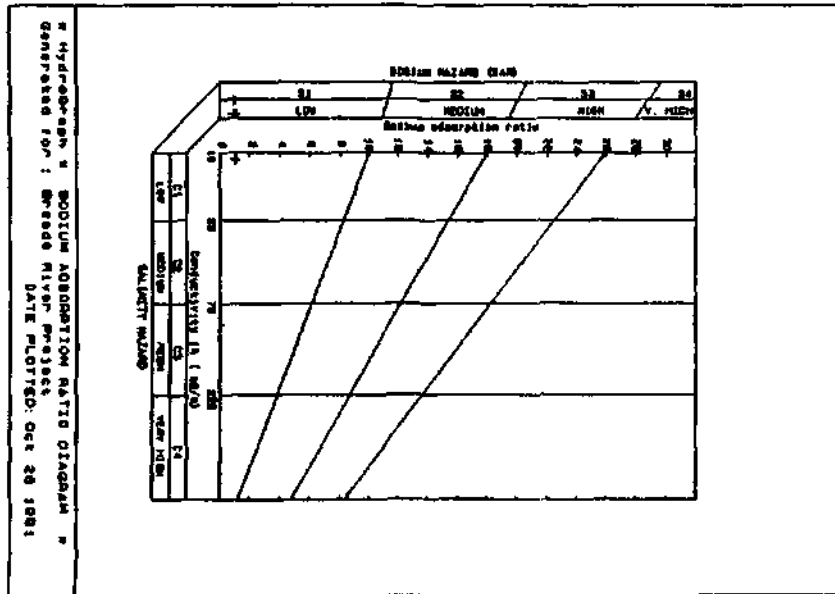
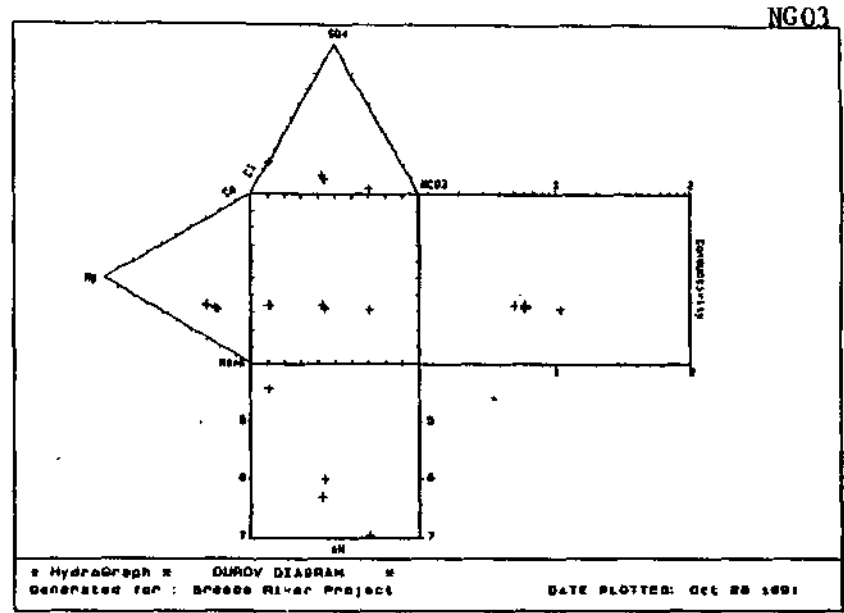
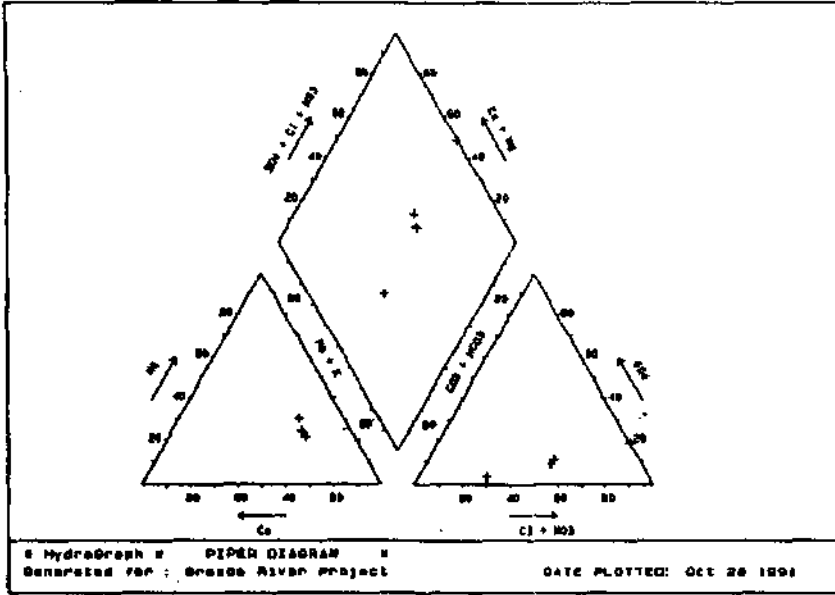

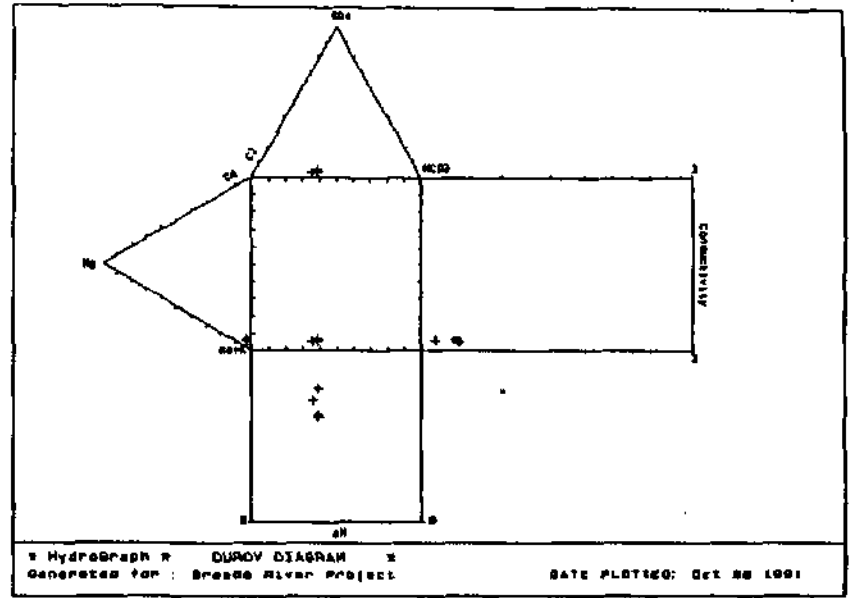
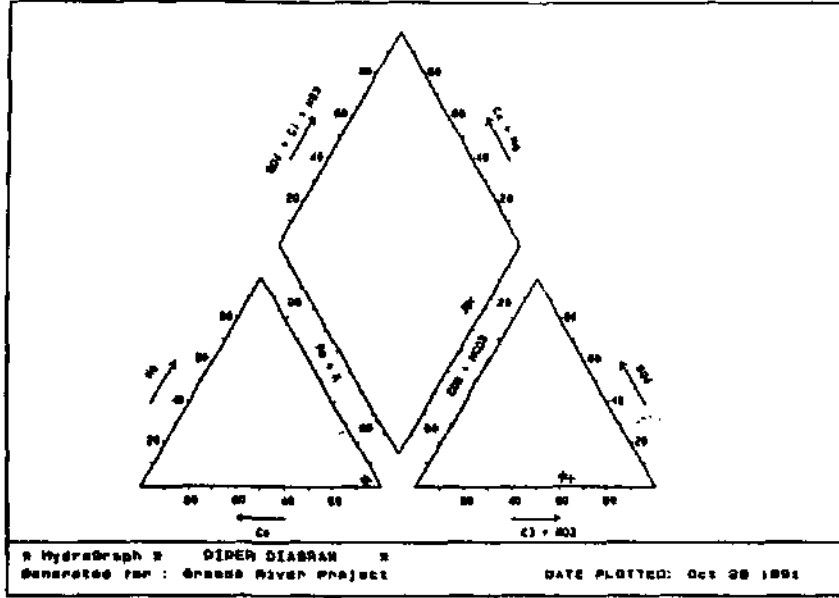

205

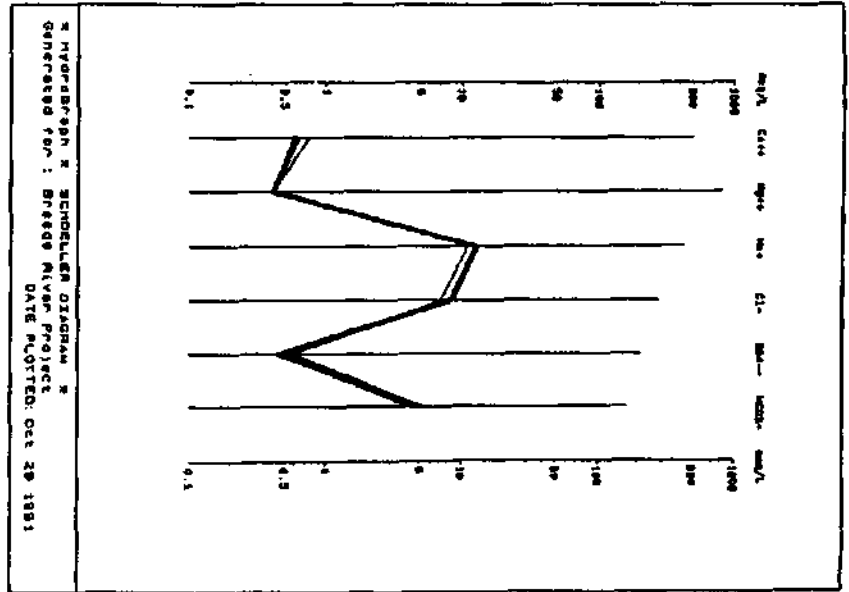
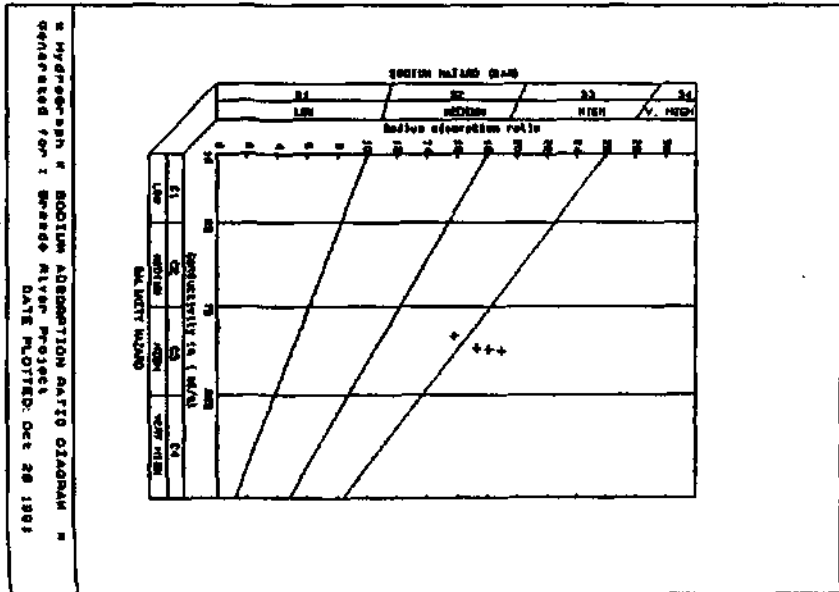

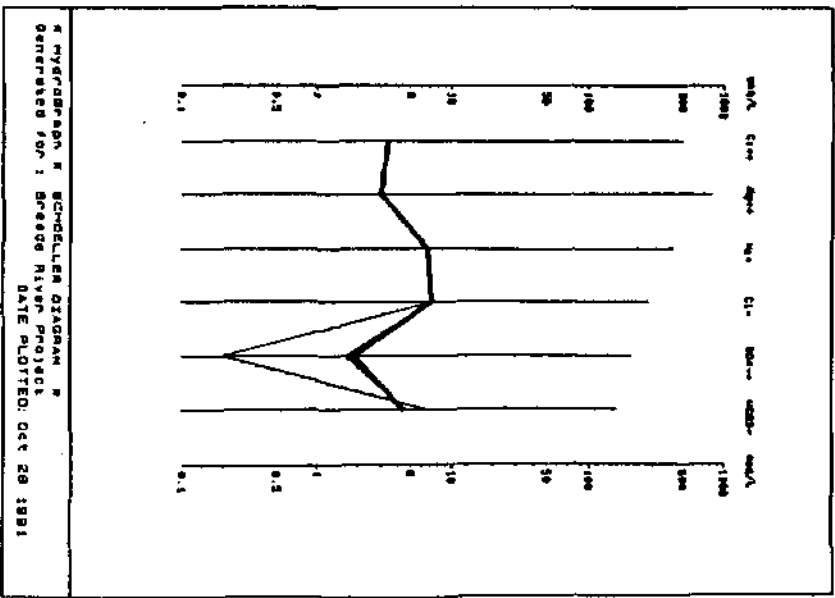
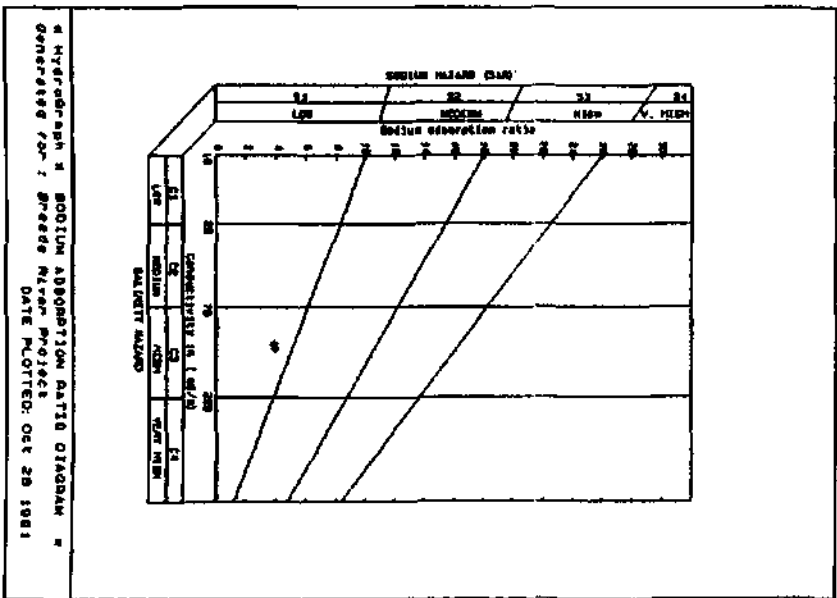
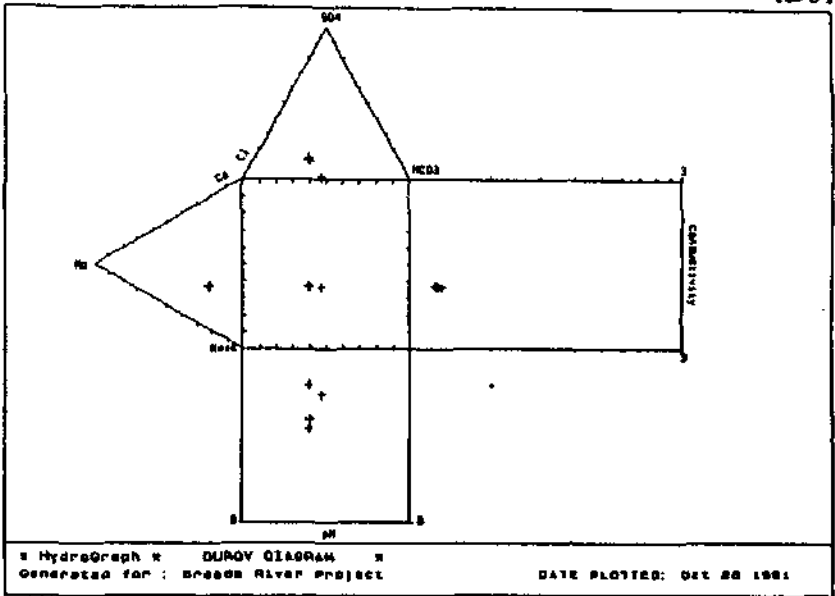
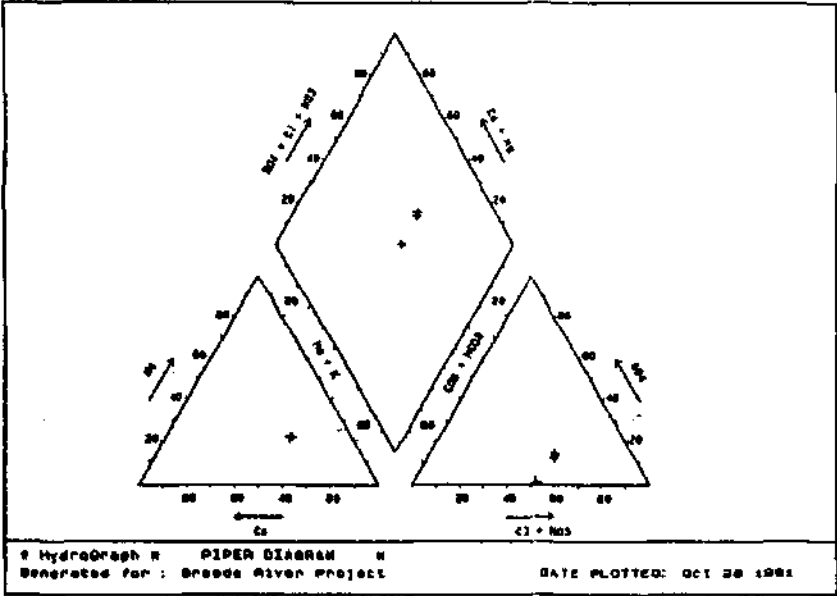

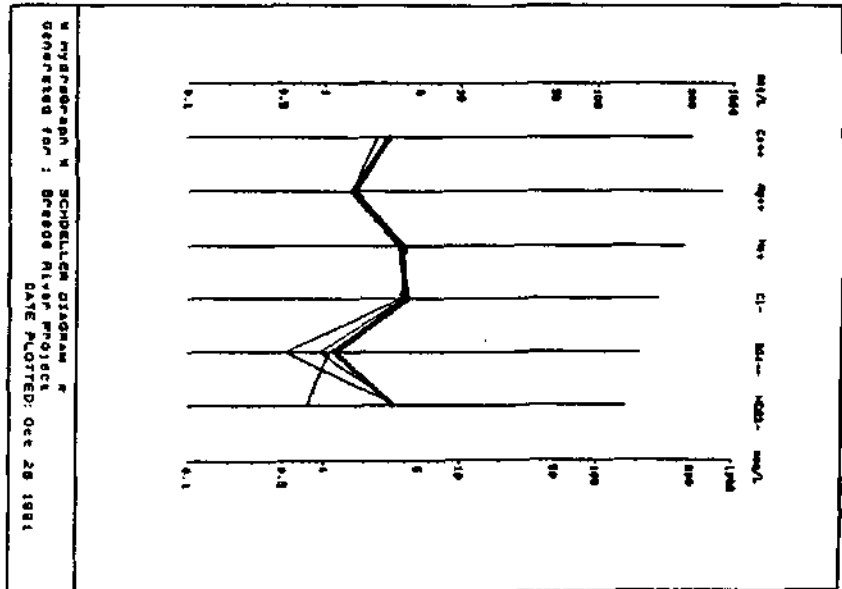
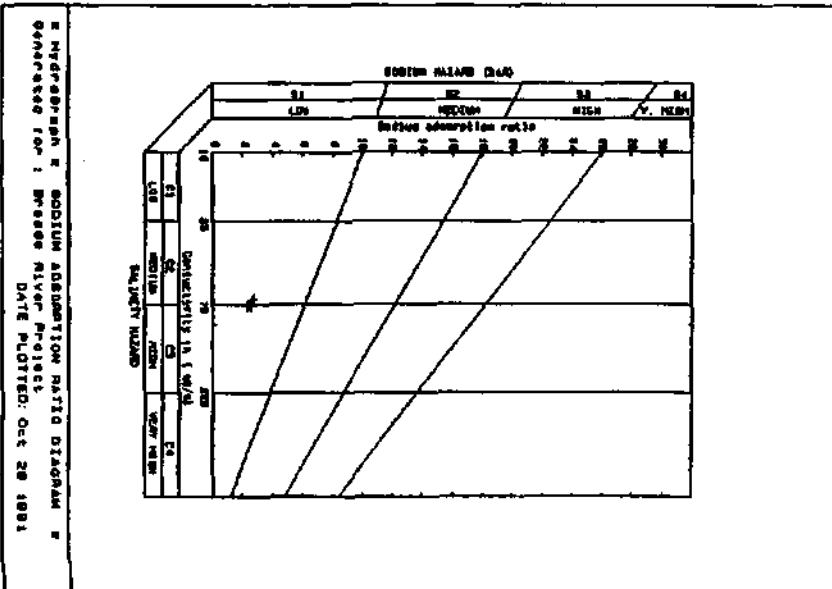
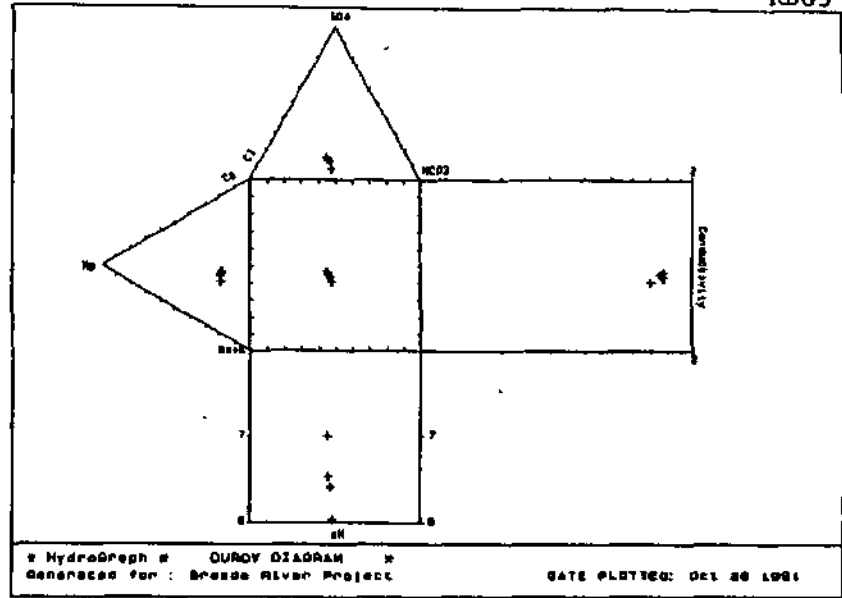
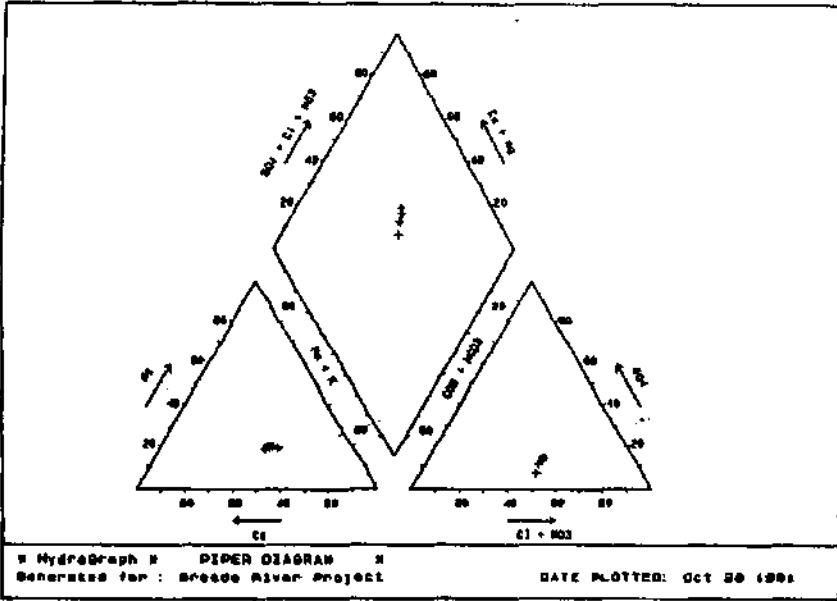

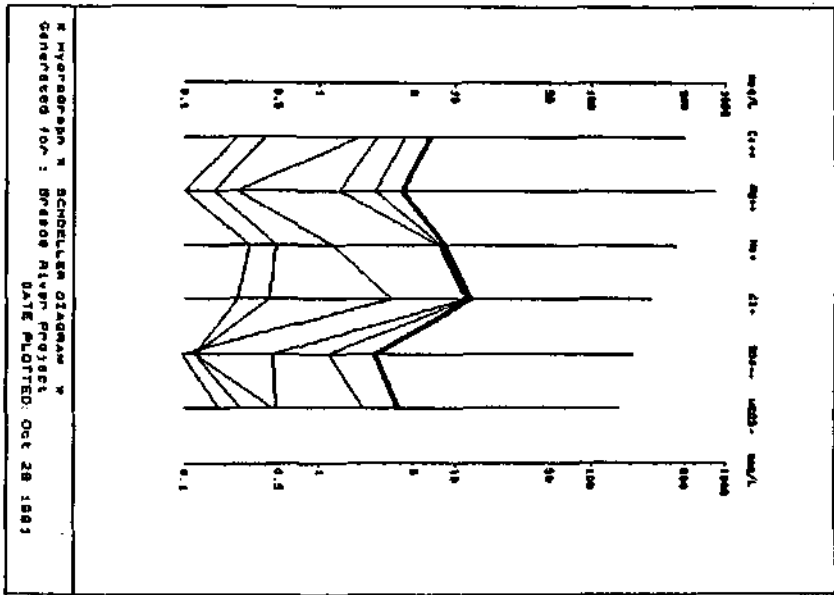
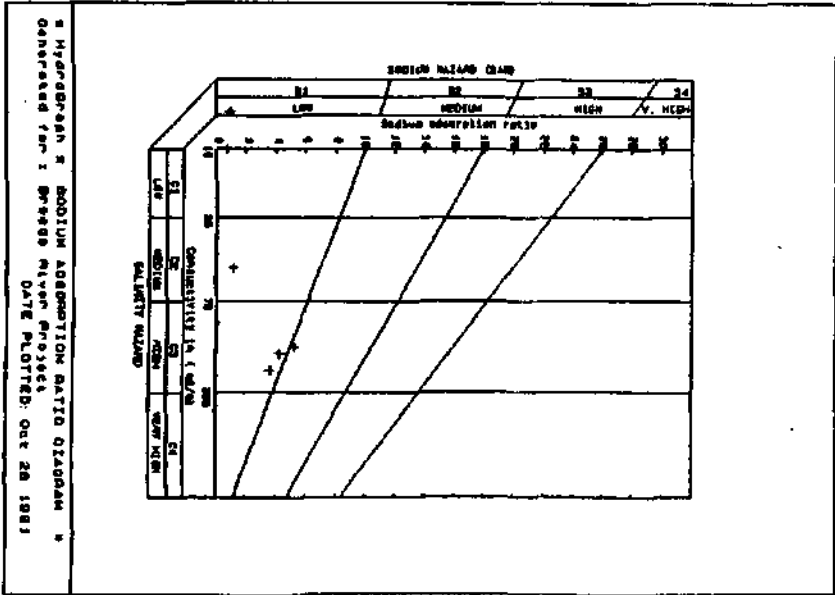
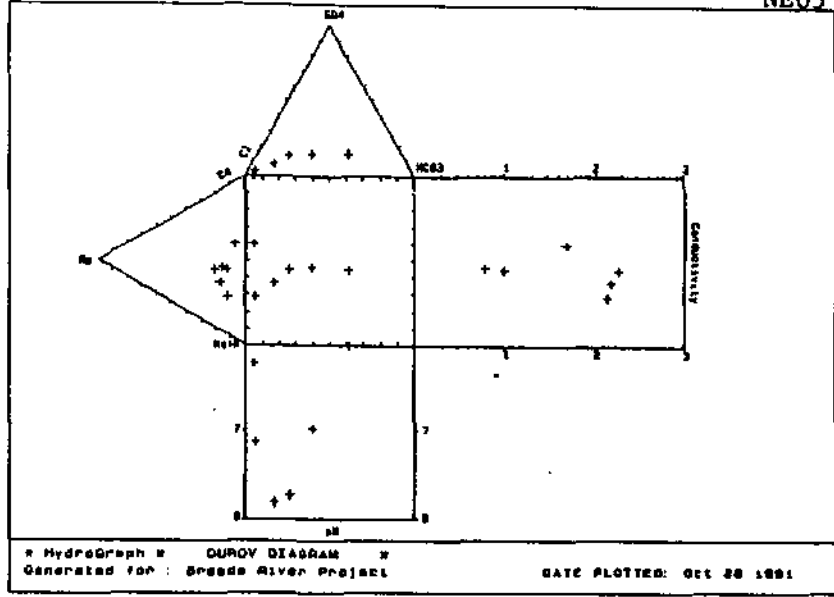
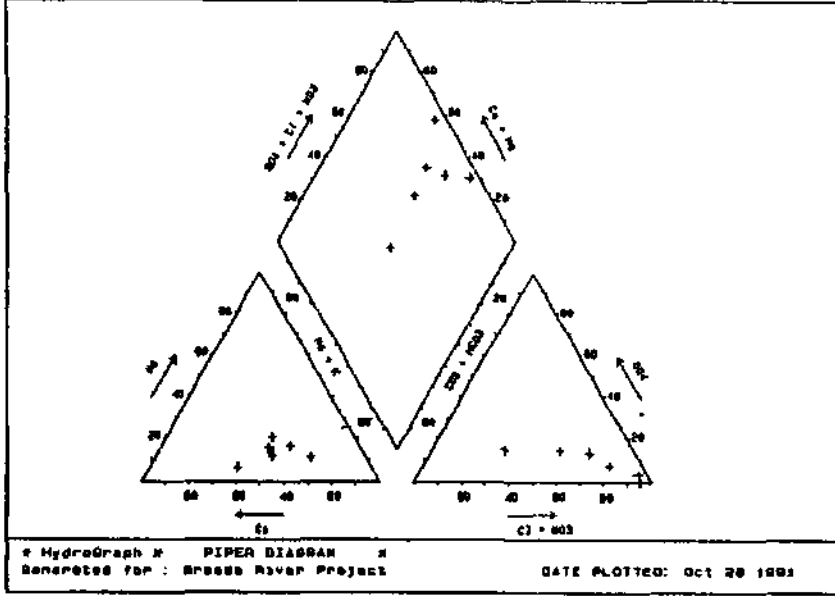

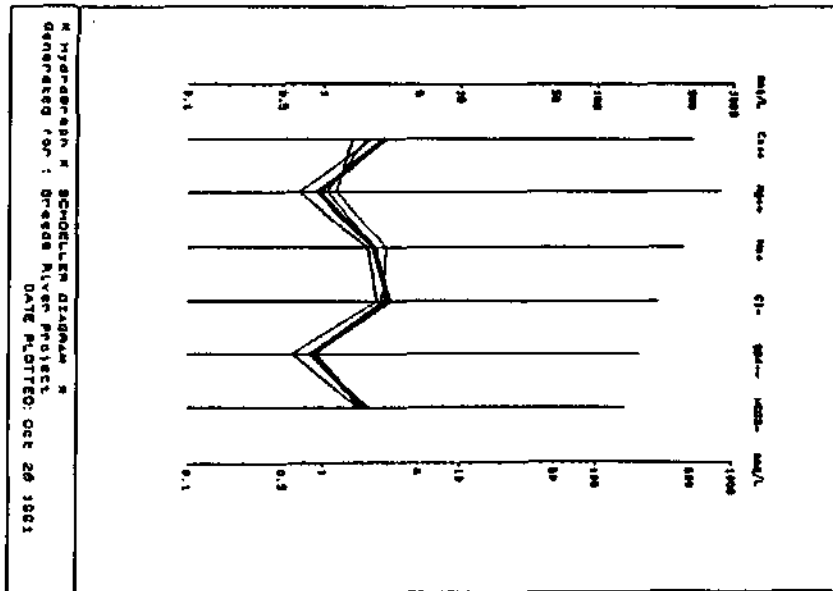
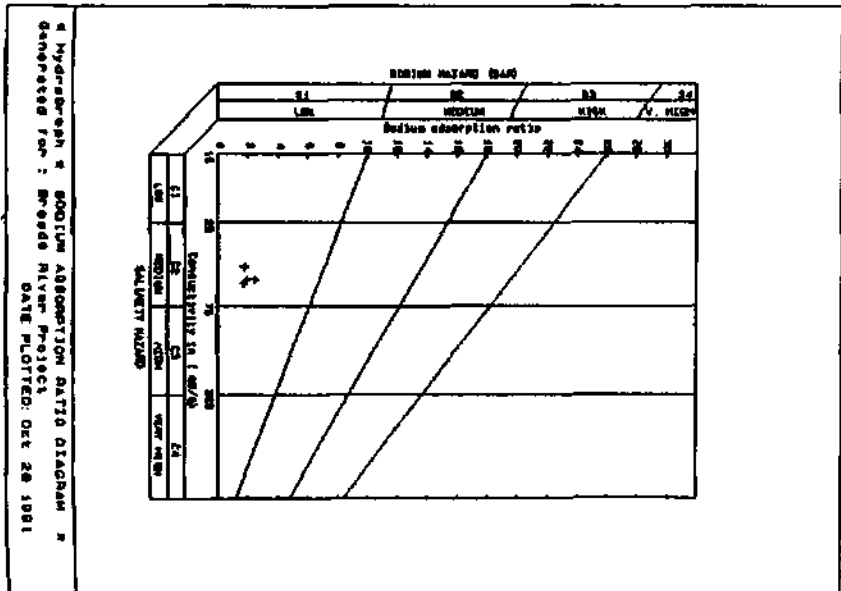
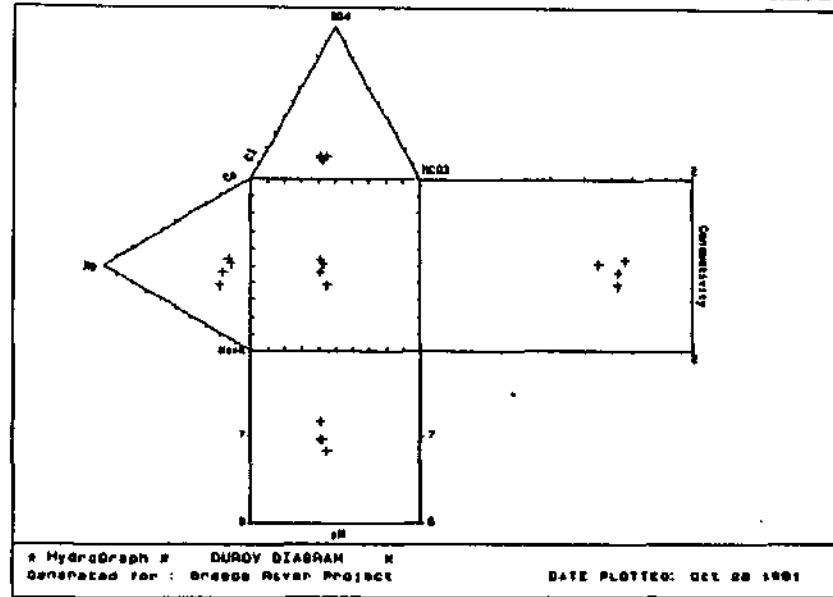
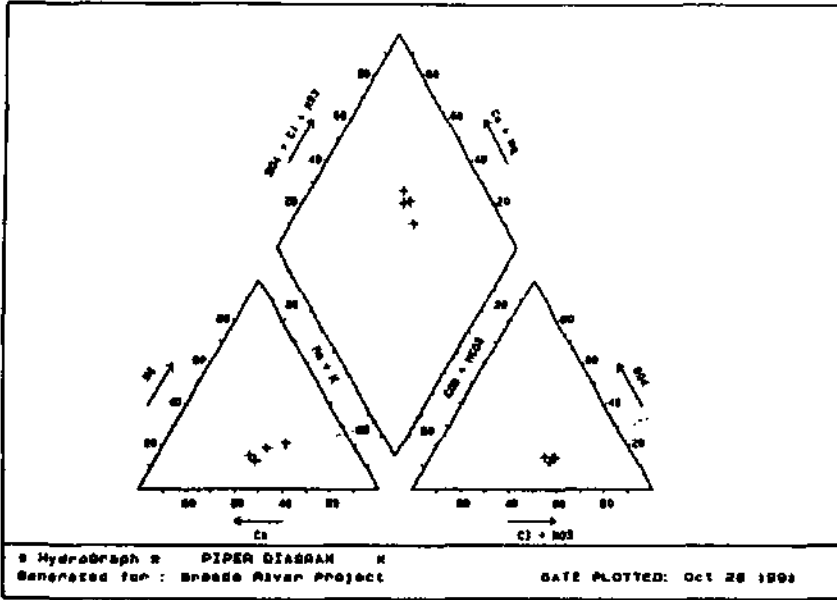

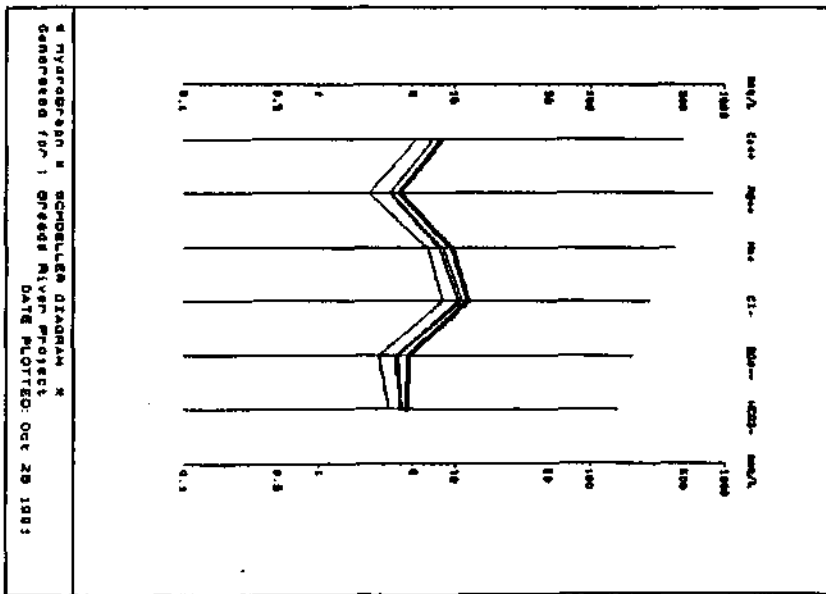
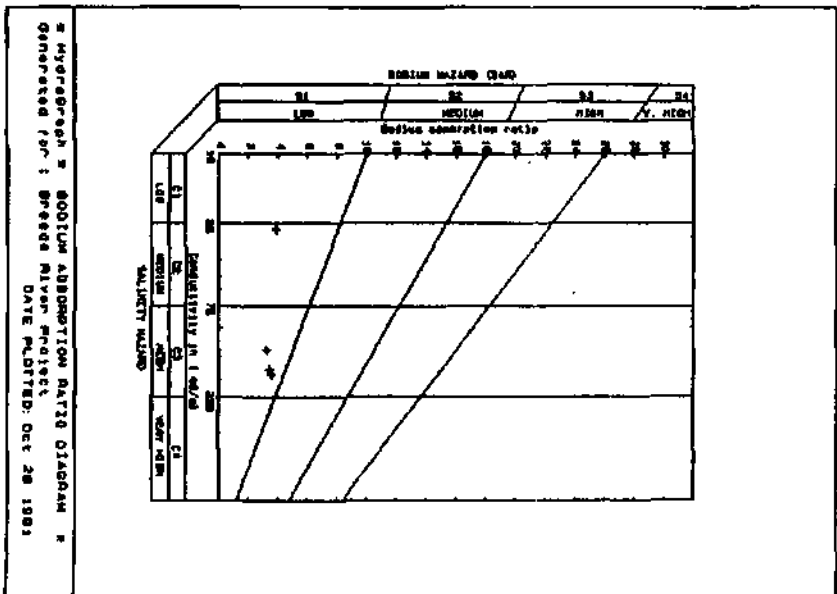
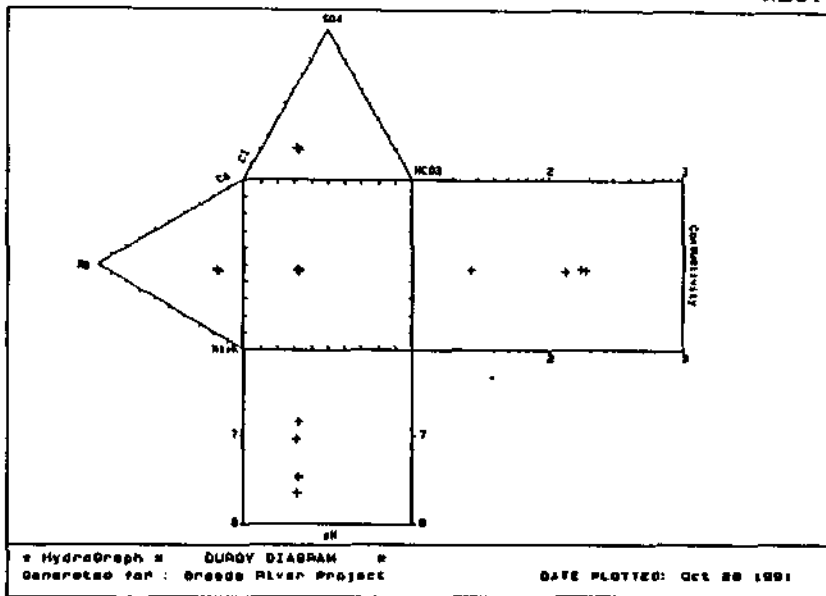
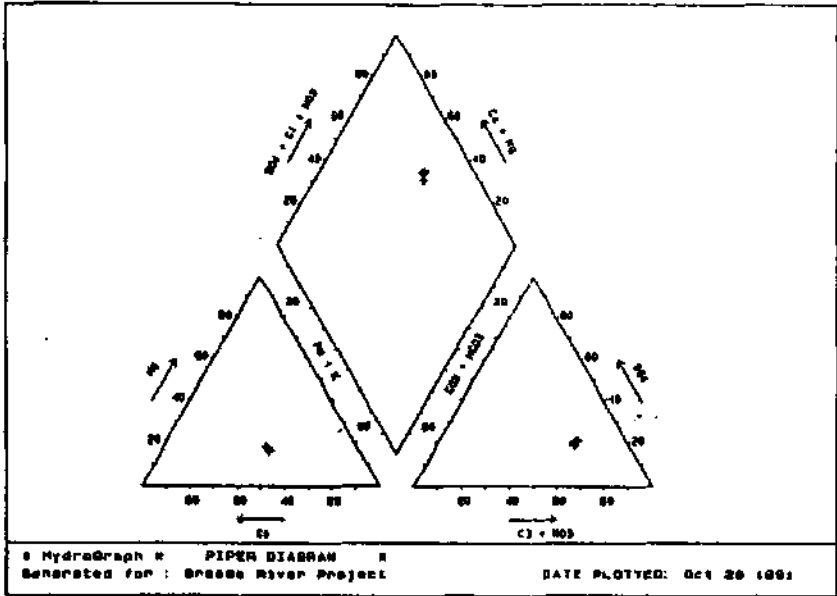

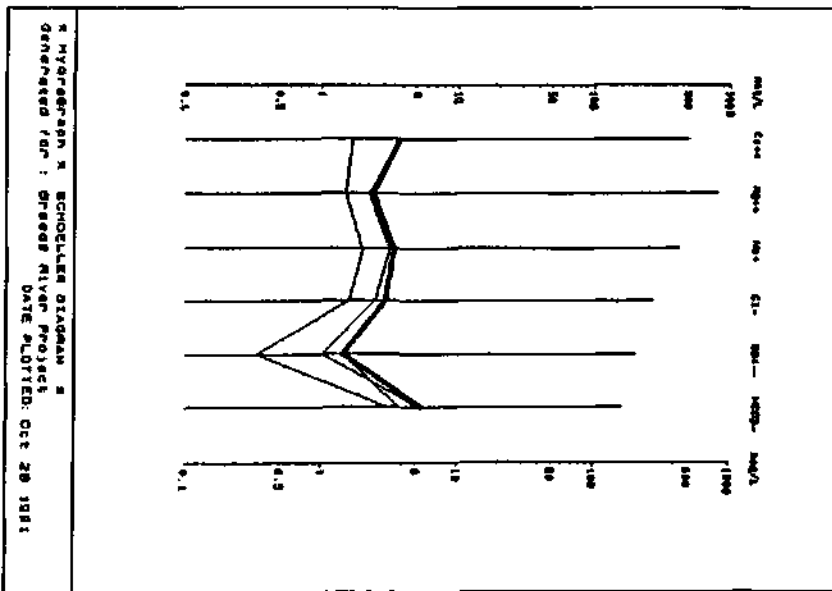
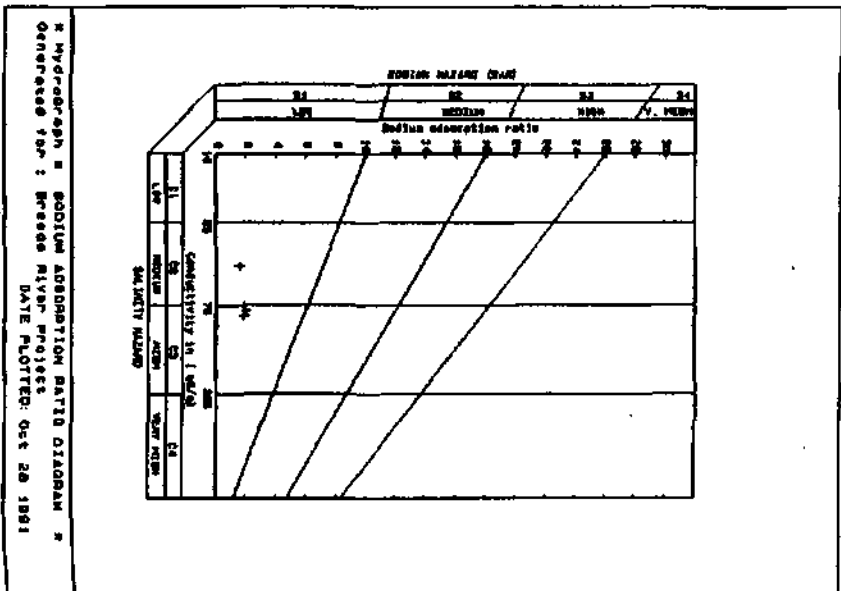
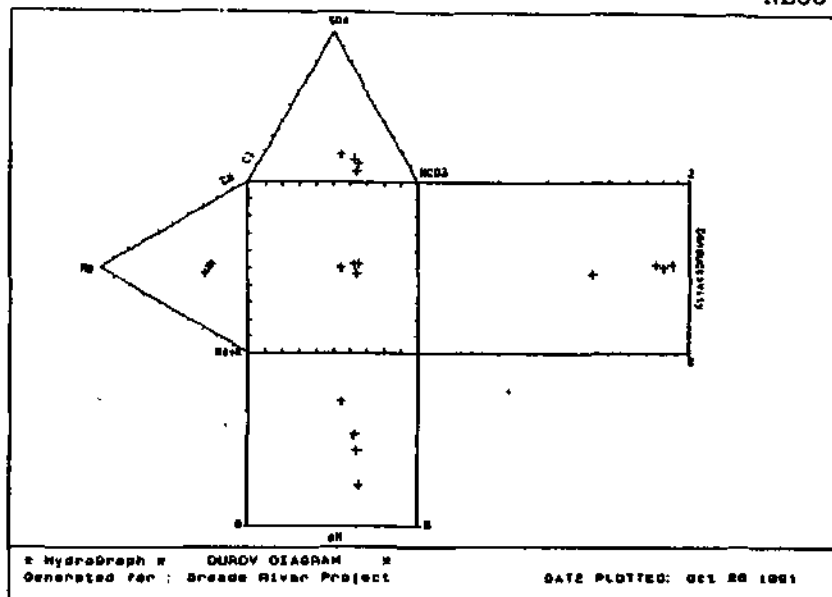
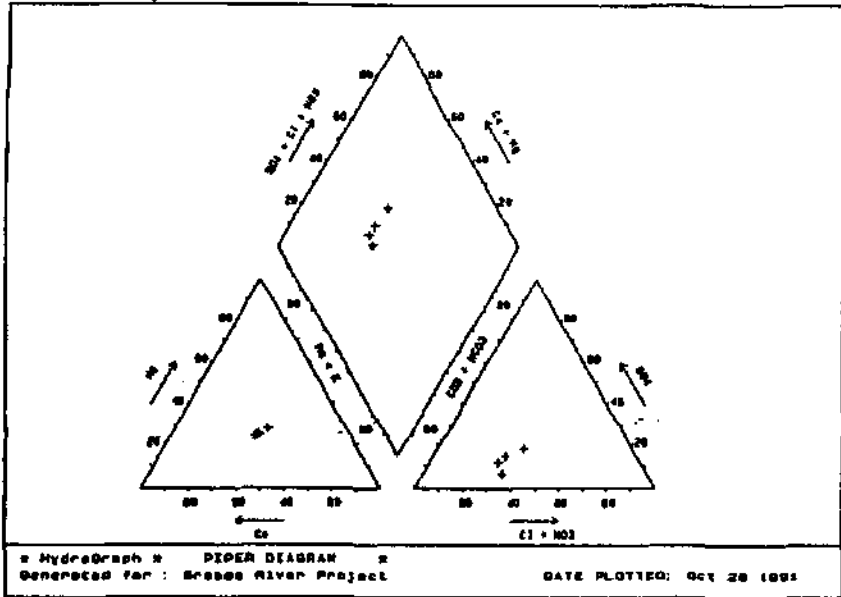

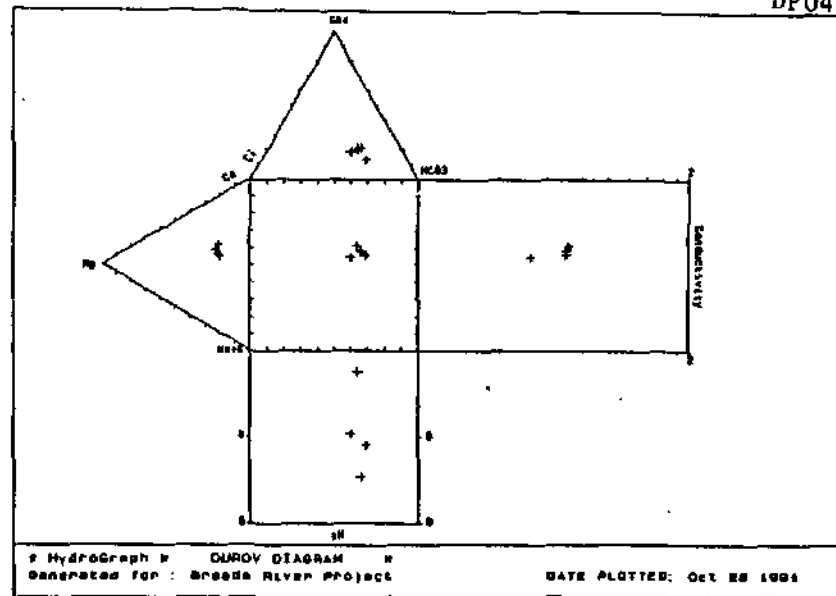
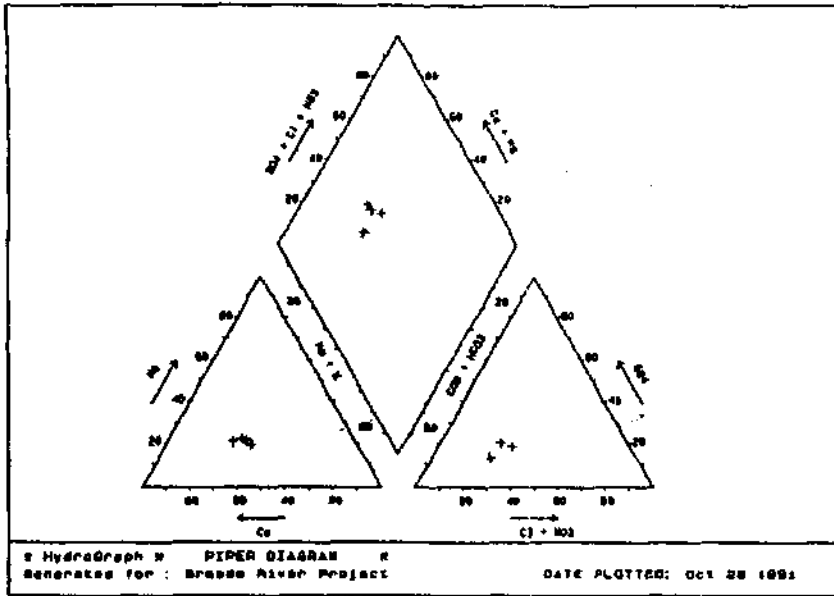

212

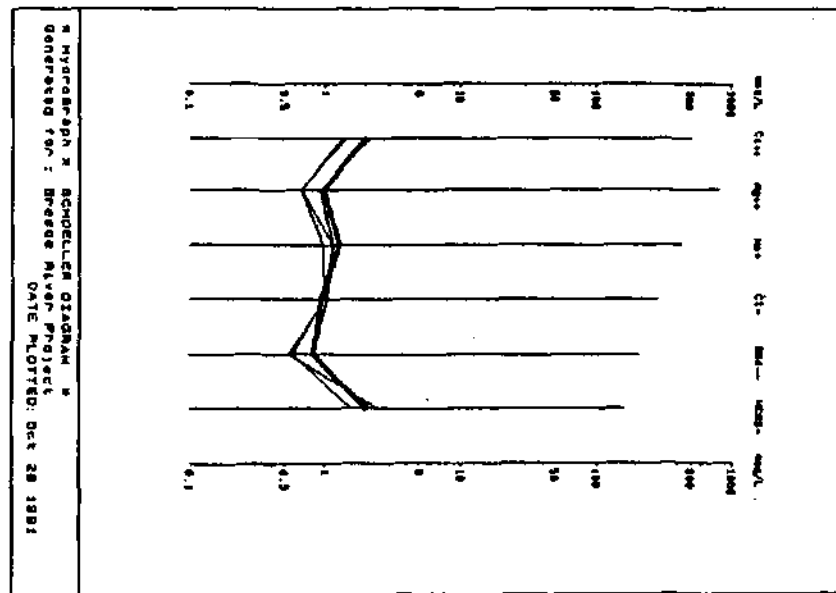
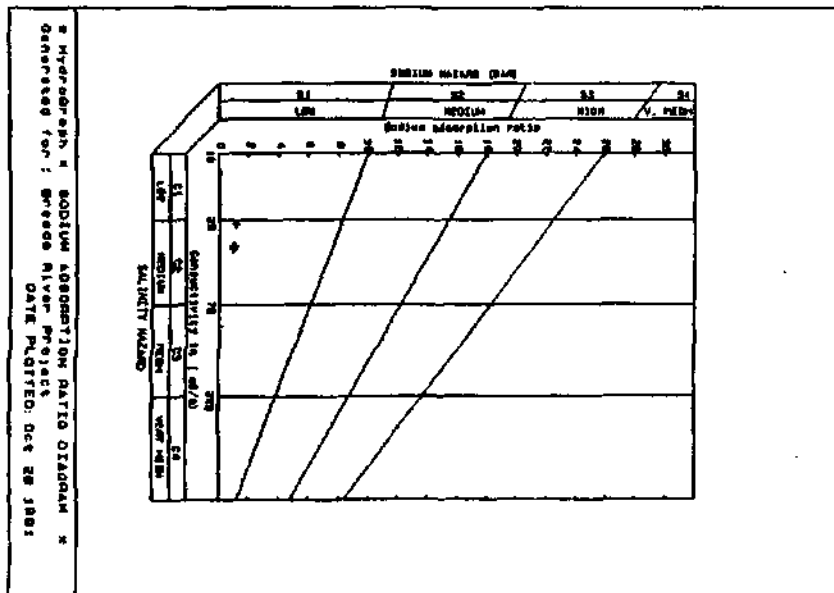

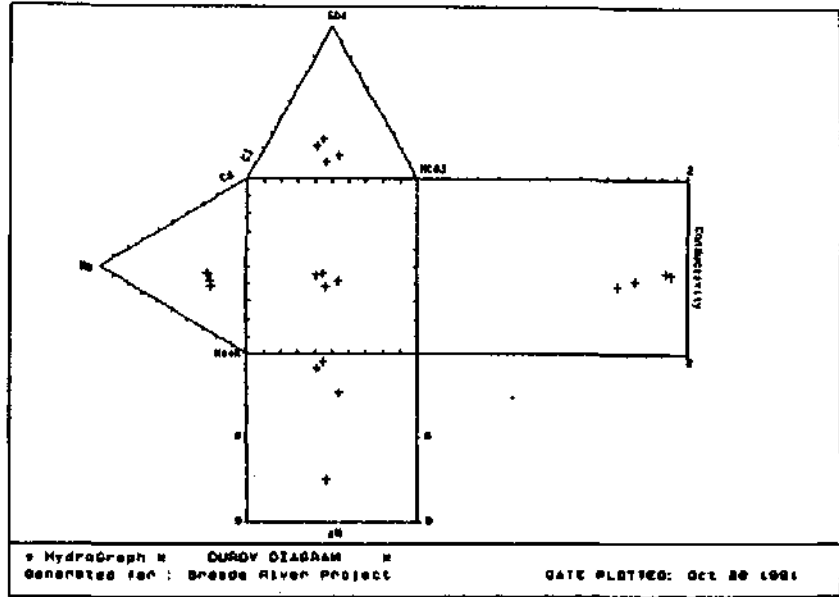
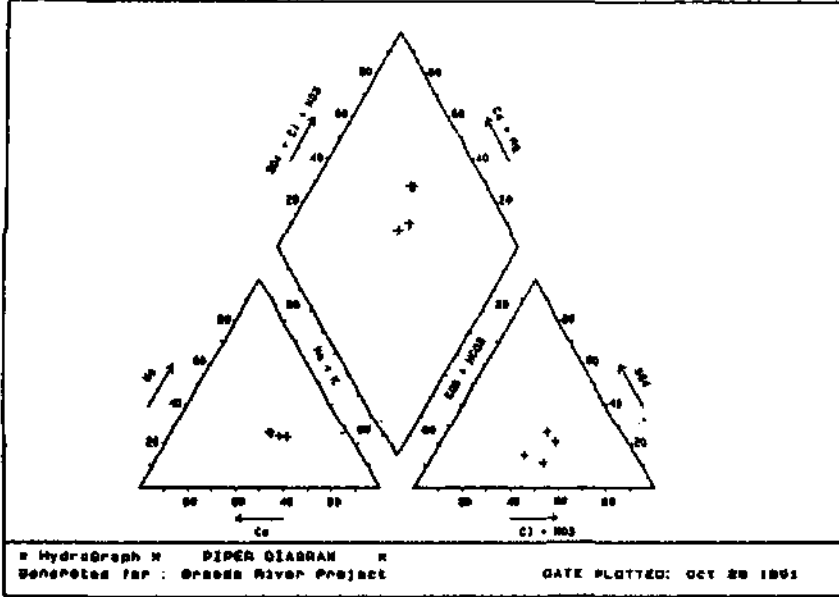

213

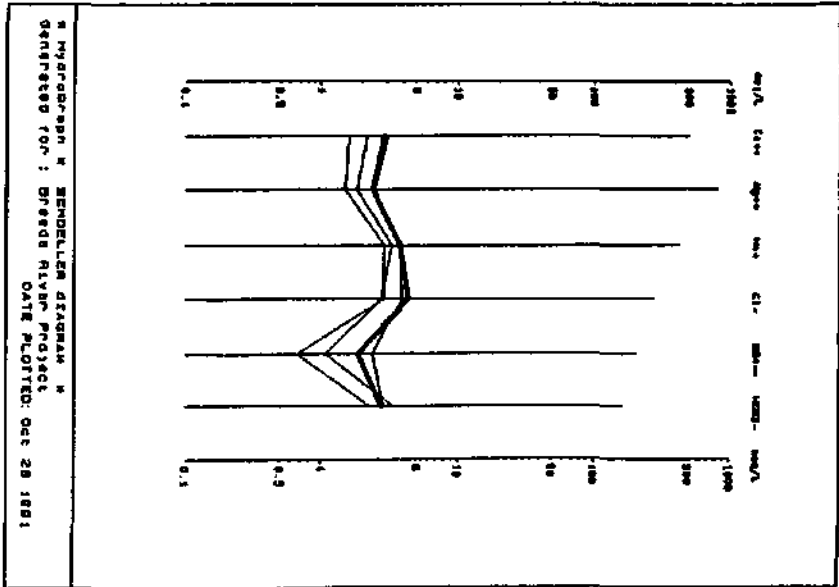
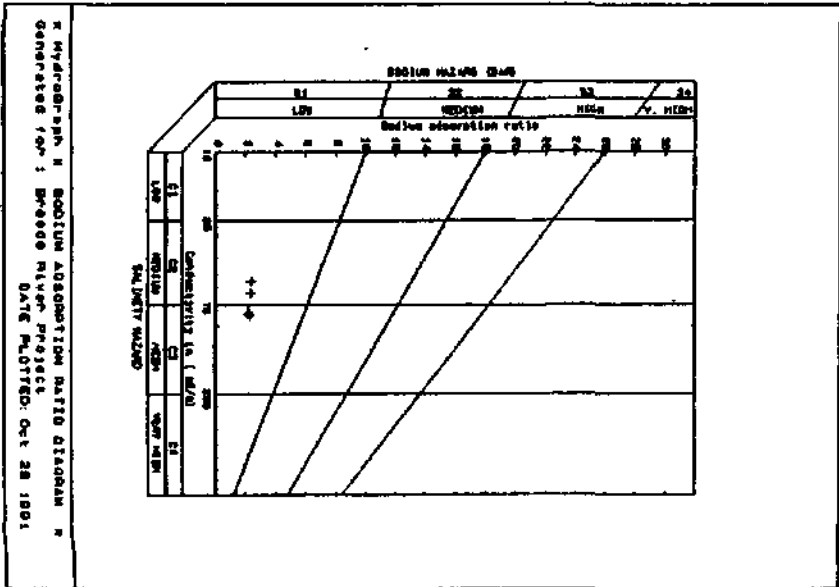

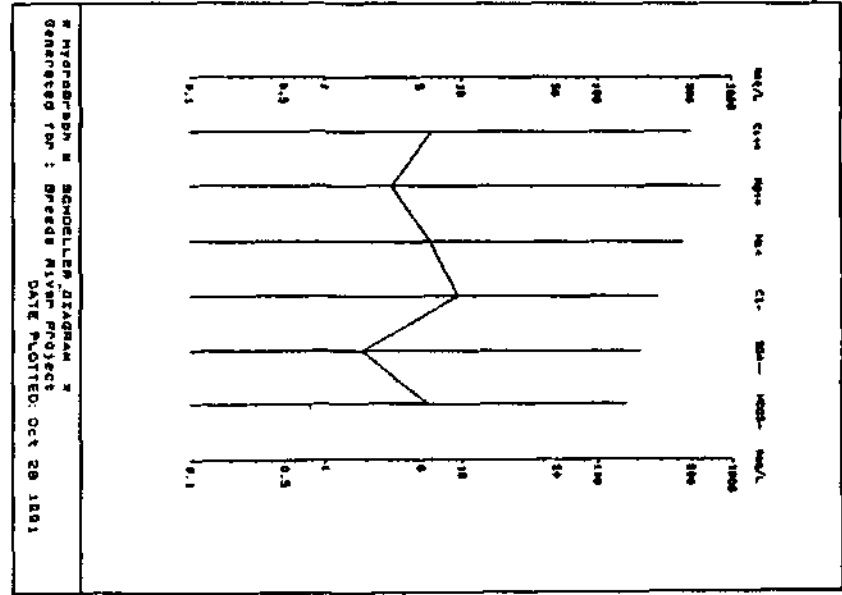
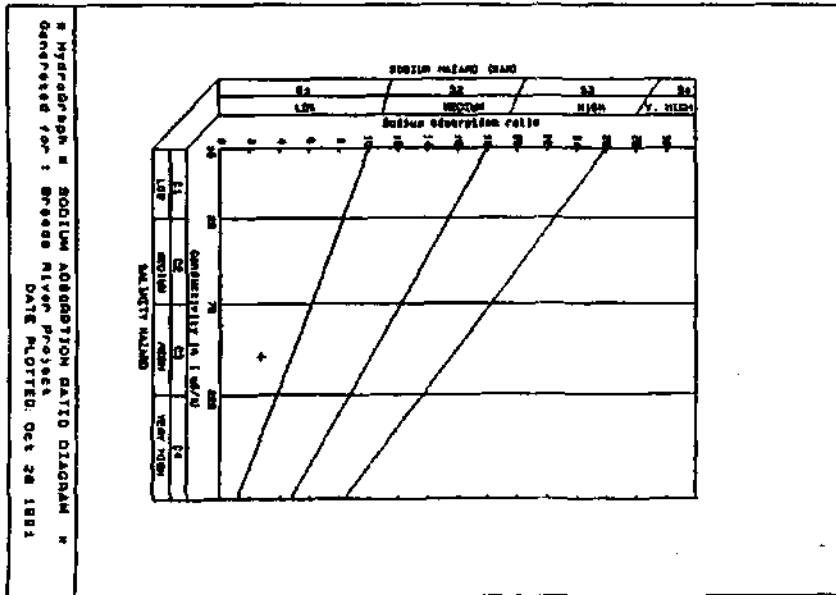
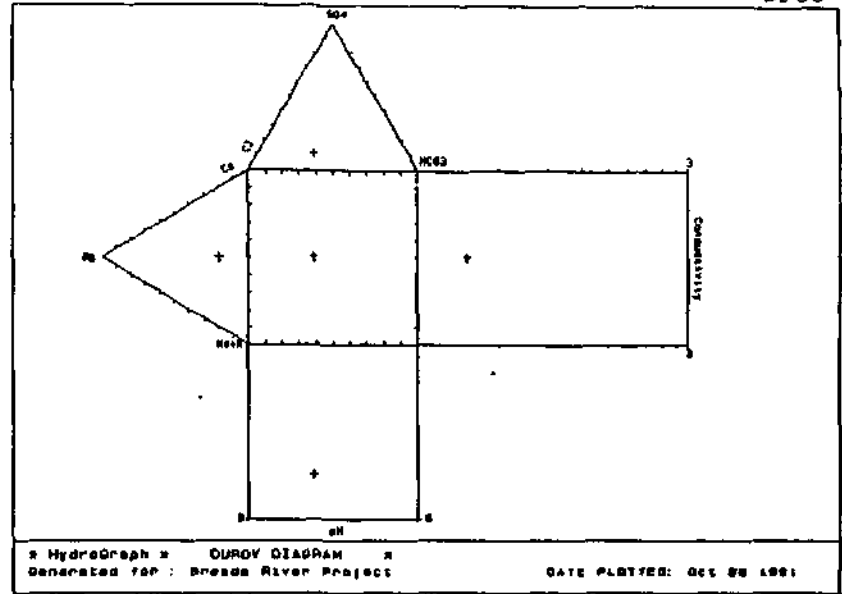
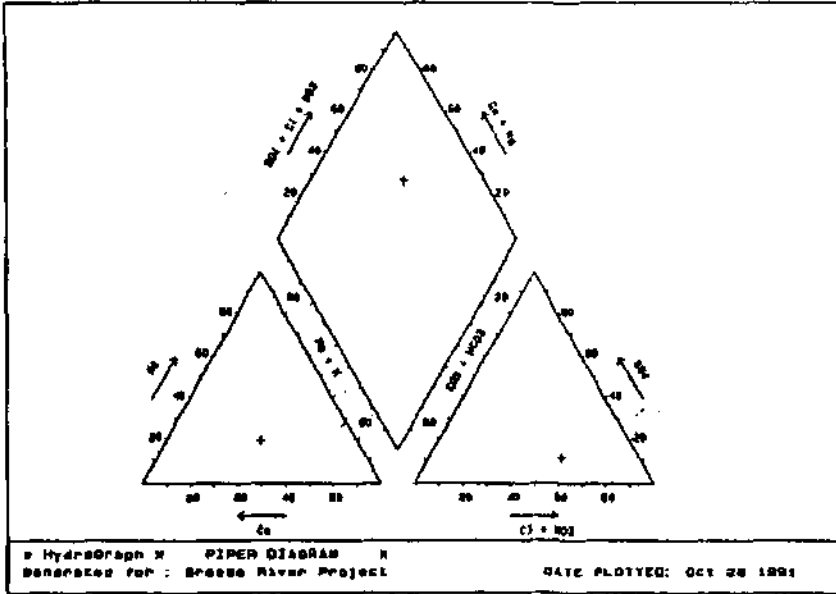

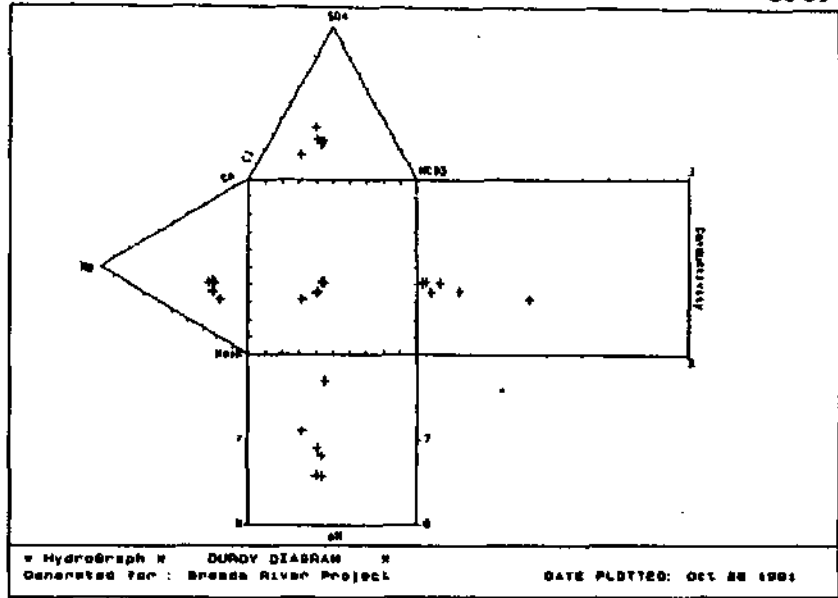
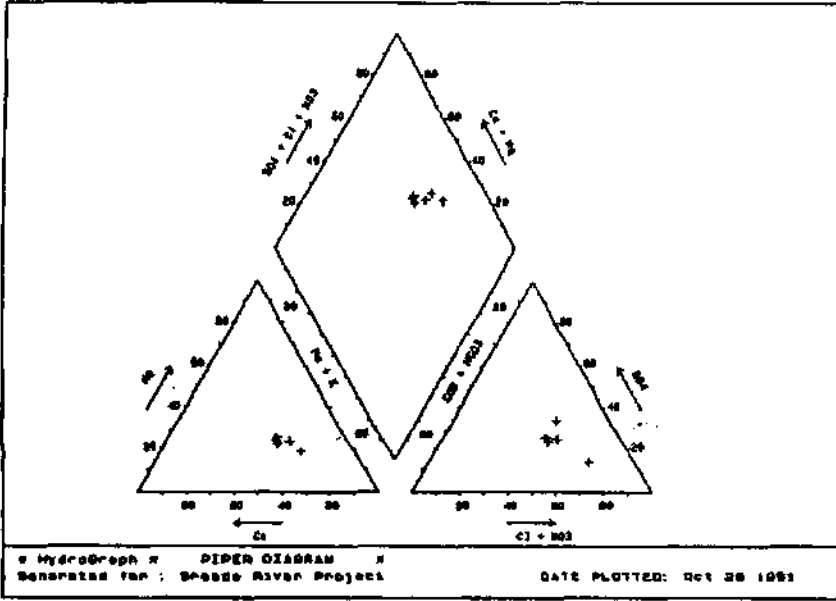

215

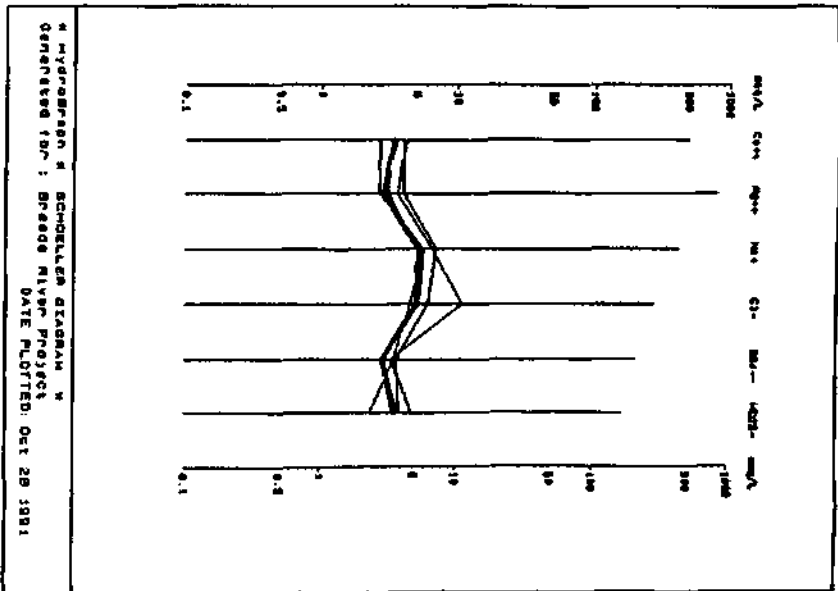
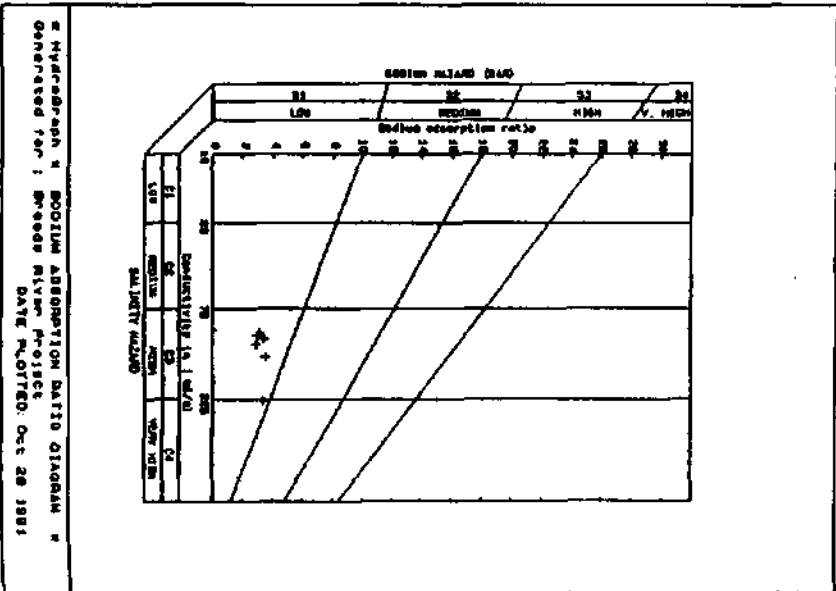

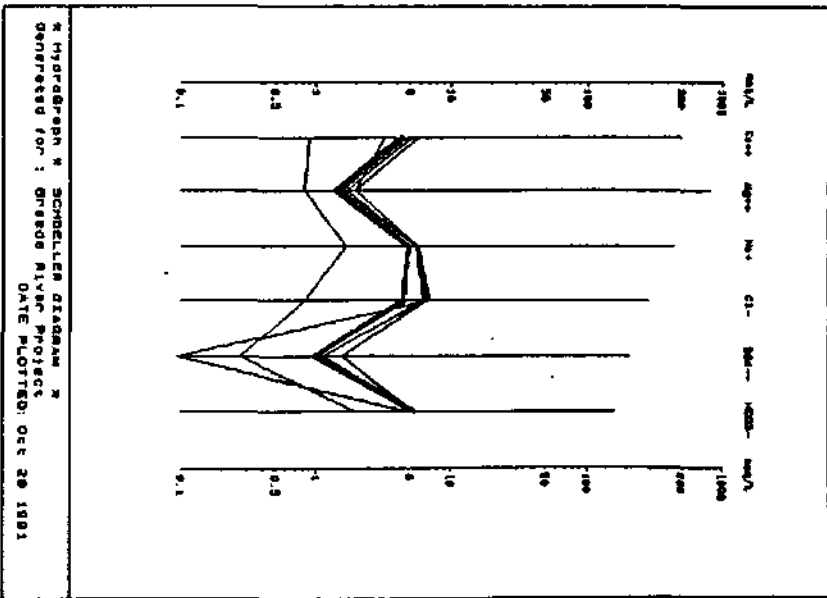
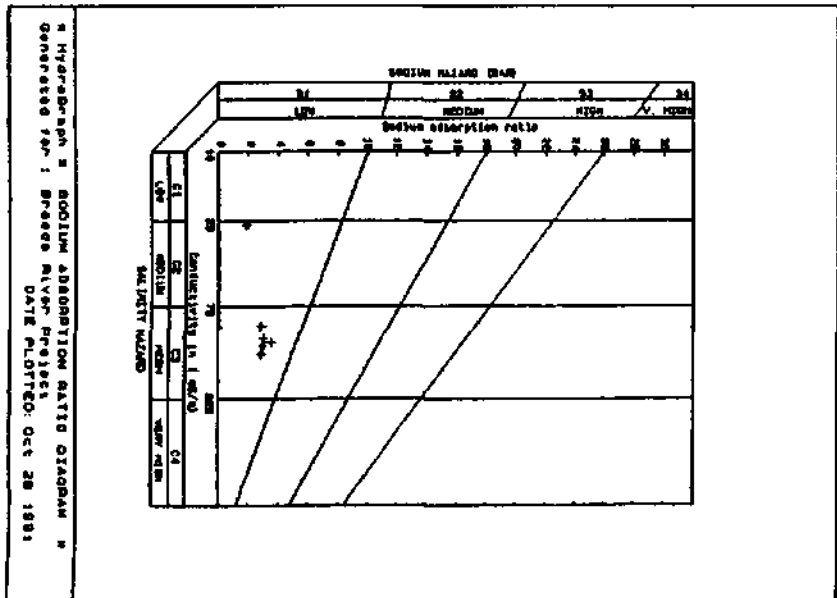
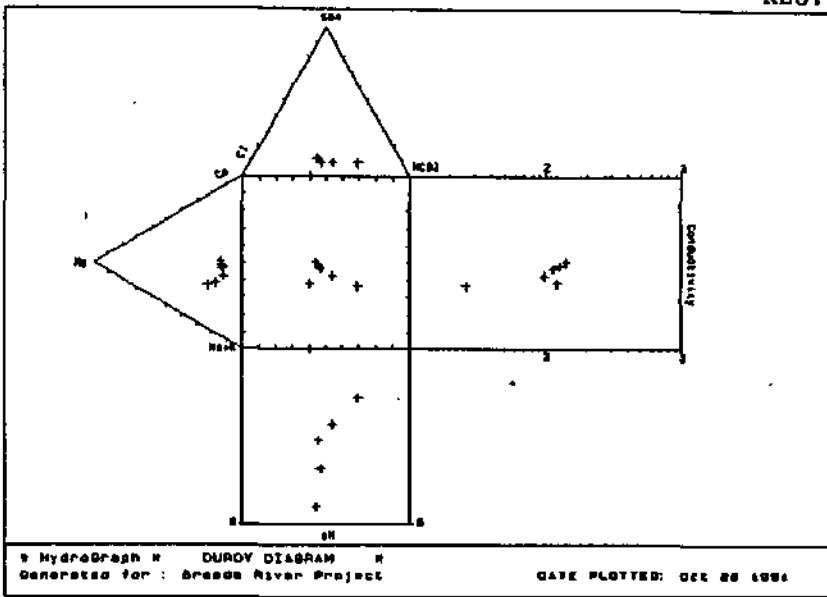
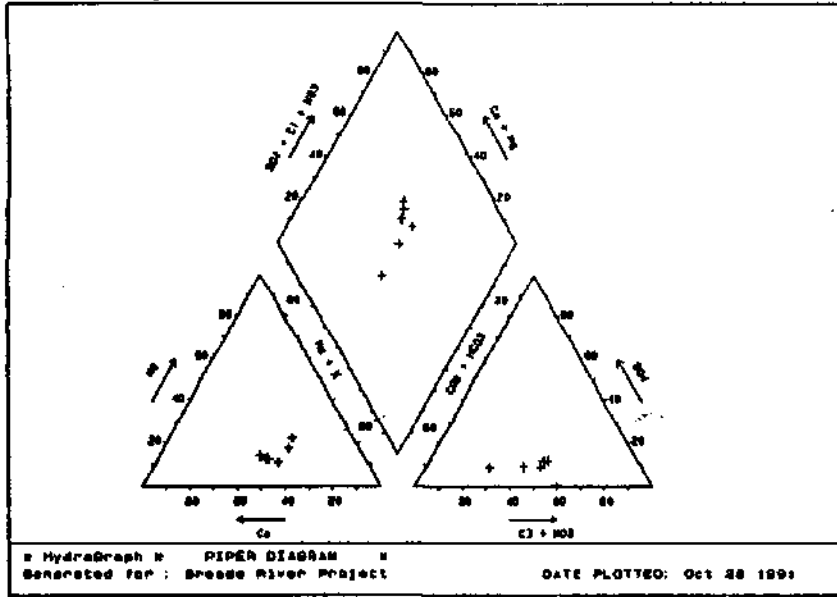

Appendix 8

Hydrochemical graphs:
Table Mountain Group

```

*****
* HydroBase * User Defined Report * Date printed : 14 April 1994
Generated for : Breede River Project
Date range : 19000101 to 19991231 * Site range : Table Mountain Sandstone
*****

```

Data from file BASICINF :

SITE_ID_NR	NR_ON_MAP	SITE_NAME	SITE_TYPE	DEPTH
3319DA00005	NG04	NAUDES BERG - KLOPPERSBOSCH	Borehole	163.00
3319DA00006	NG05	NAUDES BERG - KLOPPERSBOSCH	Borehole	158.00
3319DA00007	NG06	NAUDES BERG - KLOPPERSBOSCH	Borehole	91.40
3319DC00006	DN06	DE FONTEIN, +/- 400 m W Thearts homestead	Borehole	0.00
3319DC00027	PR18	POESJENELS RIVIER;SEWEPONTEIN	Borehole	3.00
3319DC00030	RY01	RIETVALLY:VREDENHOF	Borehole	122.00
3319DC00033	RY04	RIETVALLY:VREDENHOF	Borehole	3.00
3319DC00104	B7	DE FONTEIN, 200 m NW of homestead Mr. Thea	Borehole	0.00
3319DC00108	U	DE FONTEIN, p 300 m N of homestead	Borehole	0.00
3319DC00110	Y	POESPAS VALLY, just above dam	Borehole	0.00
3319DD00054	TY01	TAKKAPS VALLEY	Borehole	107.00
3319DD00055	TY02	TAKKAPS VALLEI	Borehole	91.00
3319DD00057	TY04	TAKKAPS VALLEI - TAKKAP	Borehole	91.00
3319DD00066	2N01	ZAND BERG FONTEIN - SANDBERG	Borehole	3.80
3319DD00068	2N03	ZAND BERG FONTEIN, Sandberg, NW of road	Borehole	0.00
3319DD00118	LE01	LA COLLINE, fountain on Skurwekop	Fountain	0.00
3319DD00124	CD1A	LAUGHING WATERS, (ca. 5 m E of switchboard	Borehole	0.00
3319DD00127	AF	VROLYKNEID, near Konings River.	Borehole	0.00

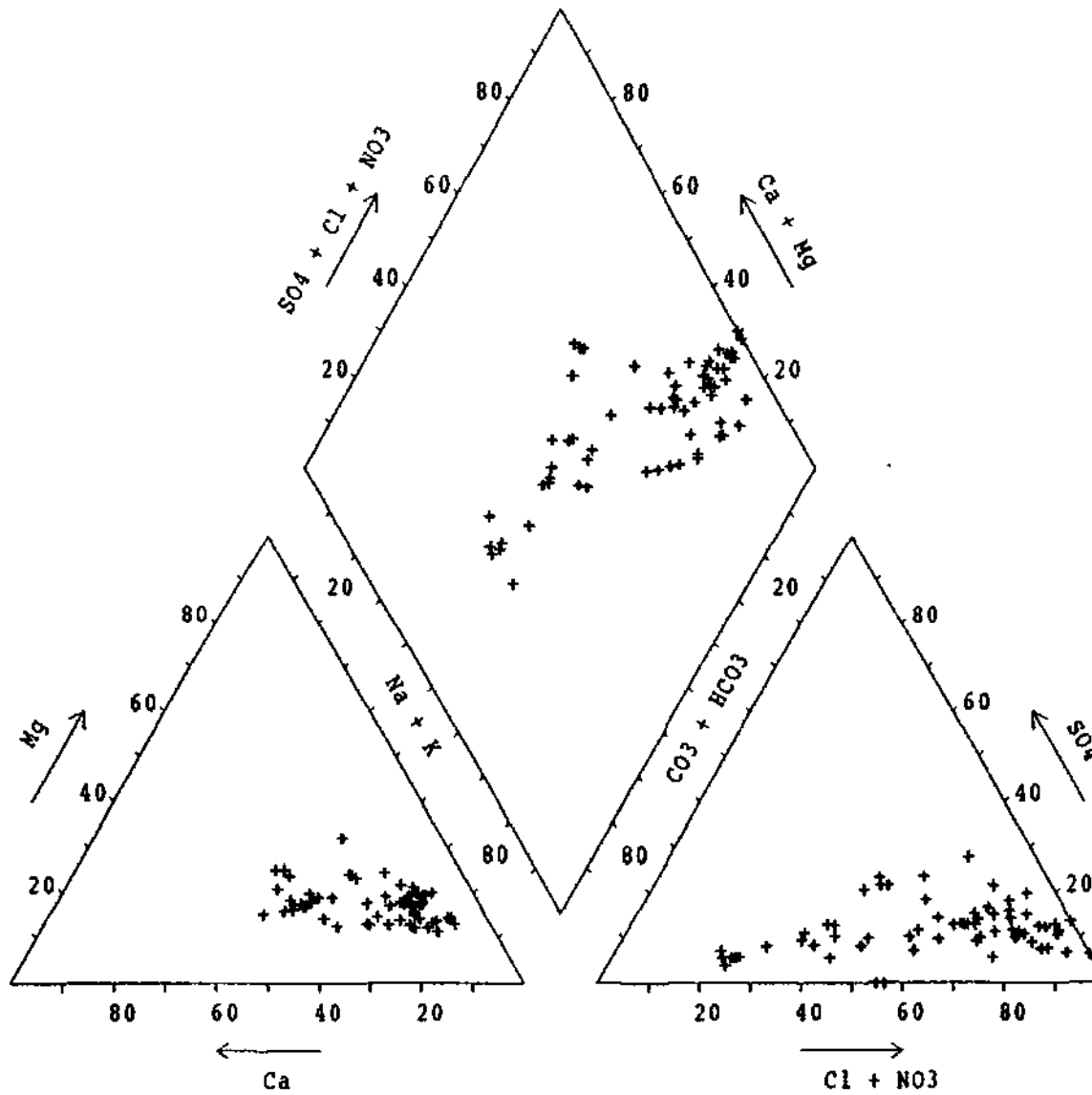

* HydroGraph * PIPER DIAGRAM : TABLE MOUNTAIN SANDSTONE *
 Generated for : Breede River Project DATE PLOTTED: Sep 20 1991

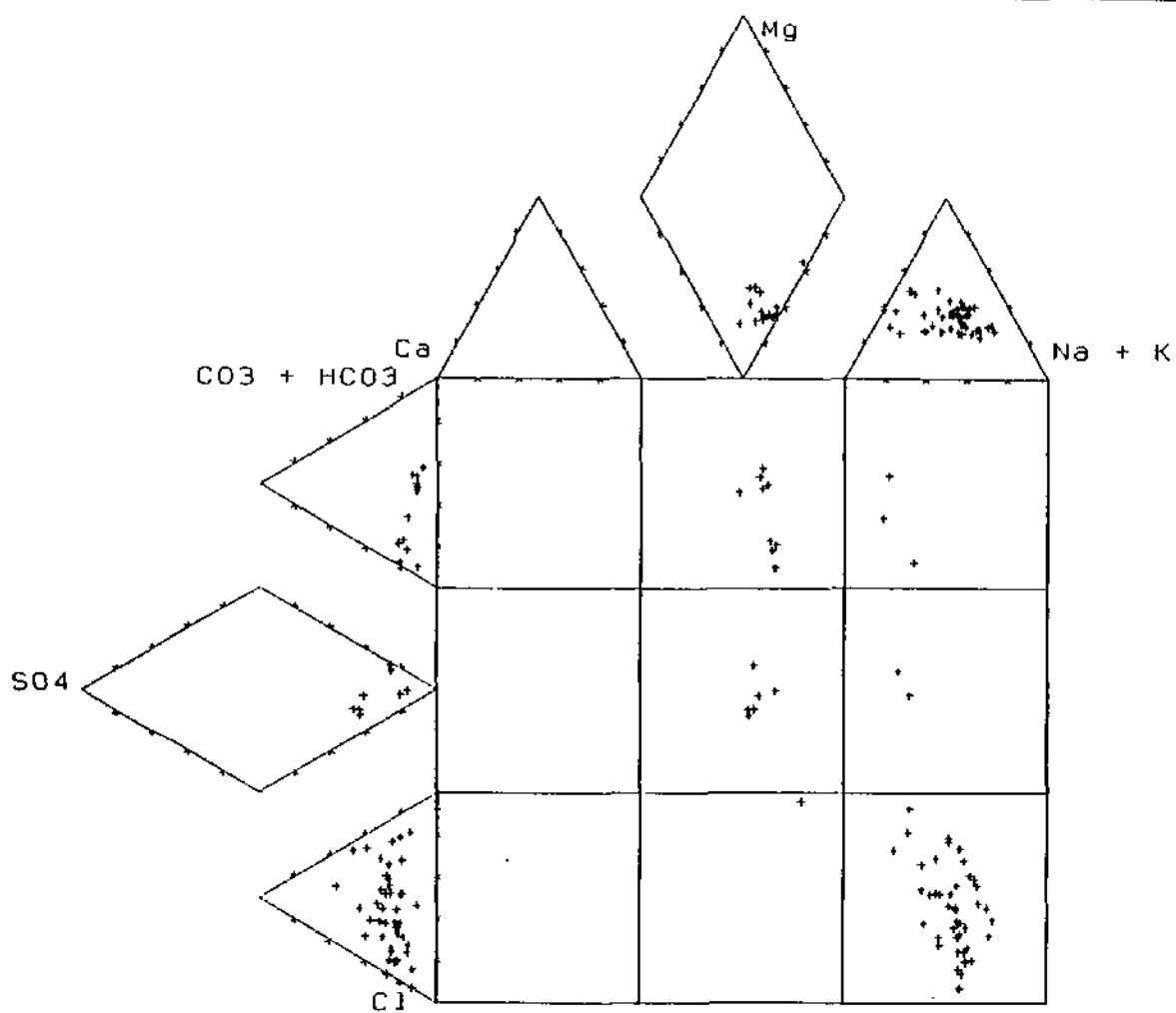

* HydroBase * EXPANDED DUROV DIAGRAM : TMS * DATE PLOTTED: Oct 08 1991
 Generated for : Breede River Project

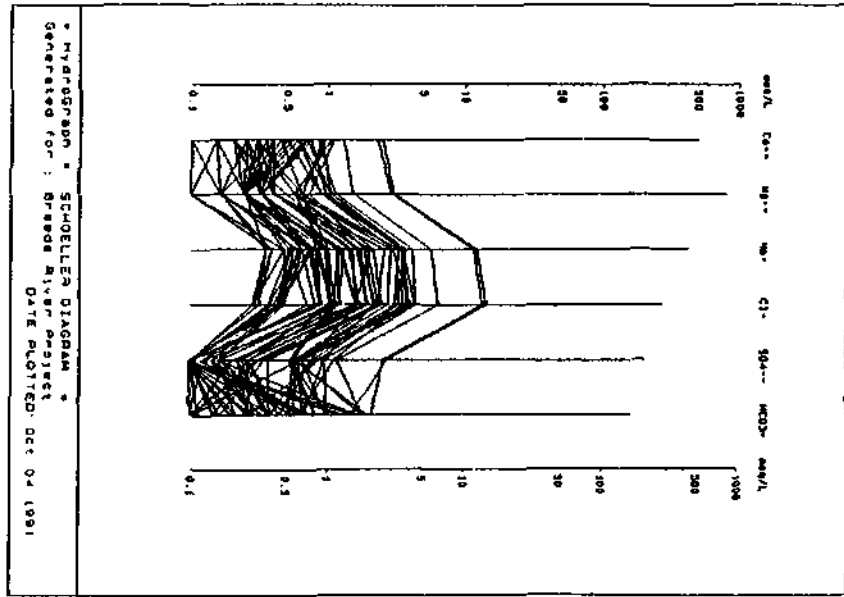
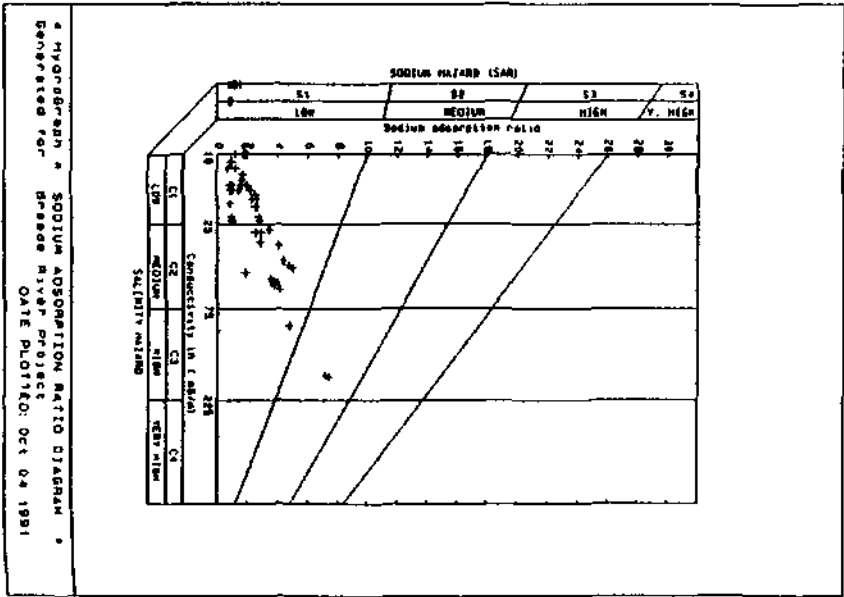
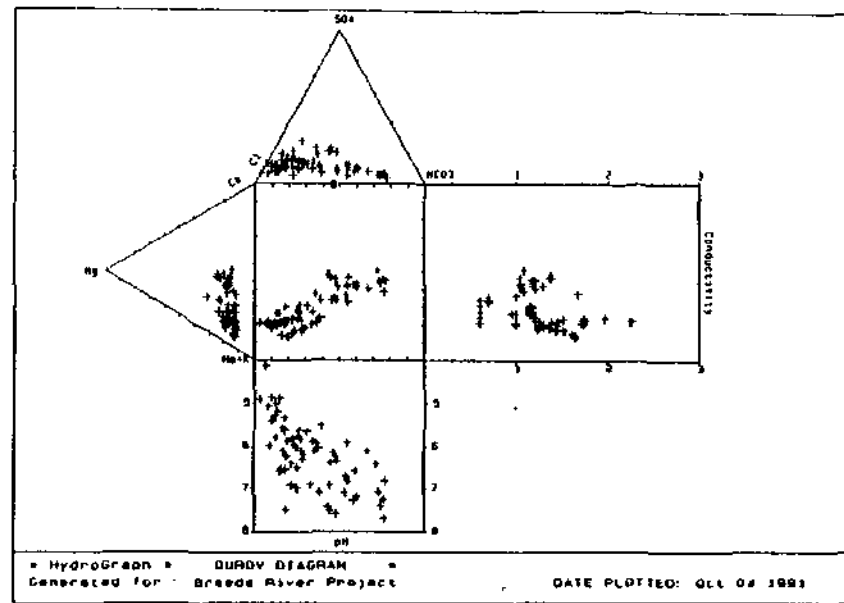
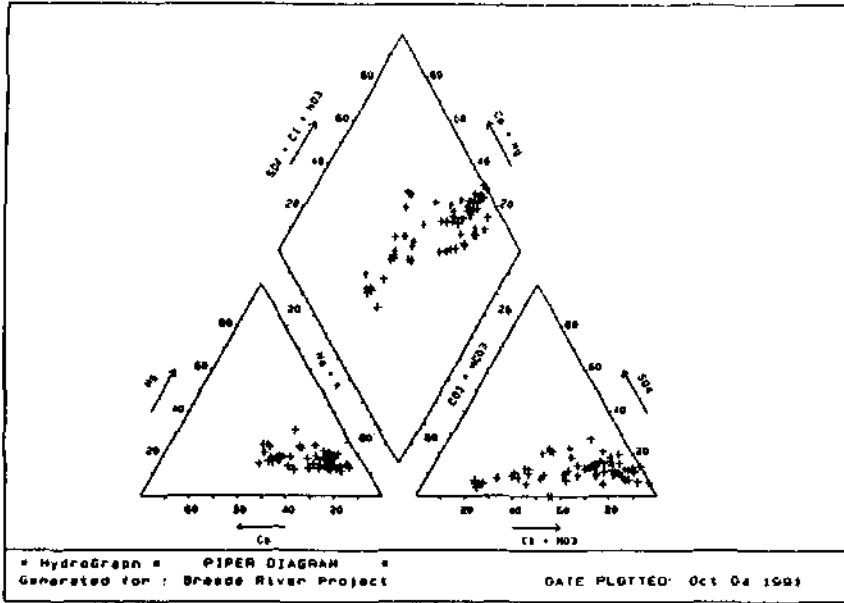

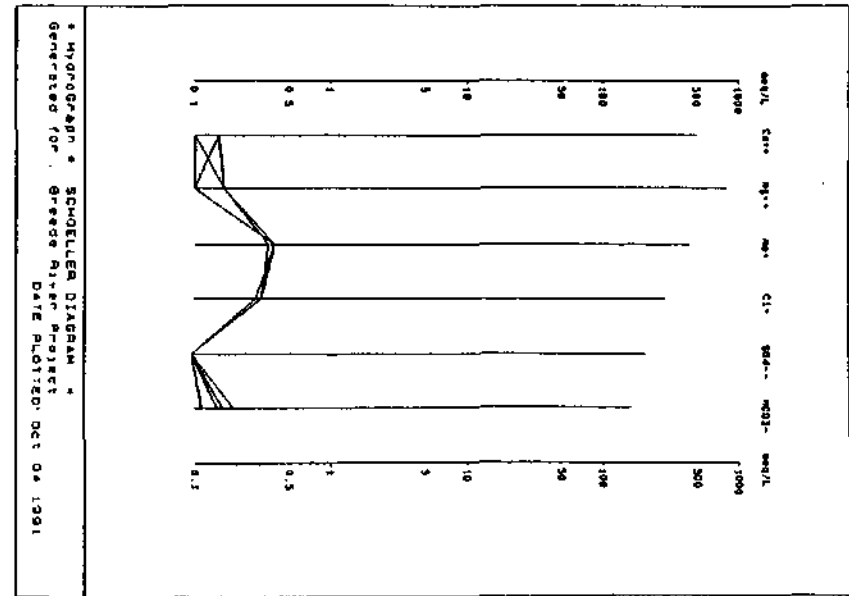
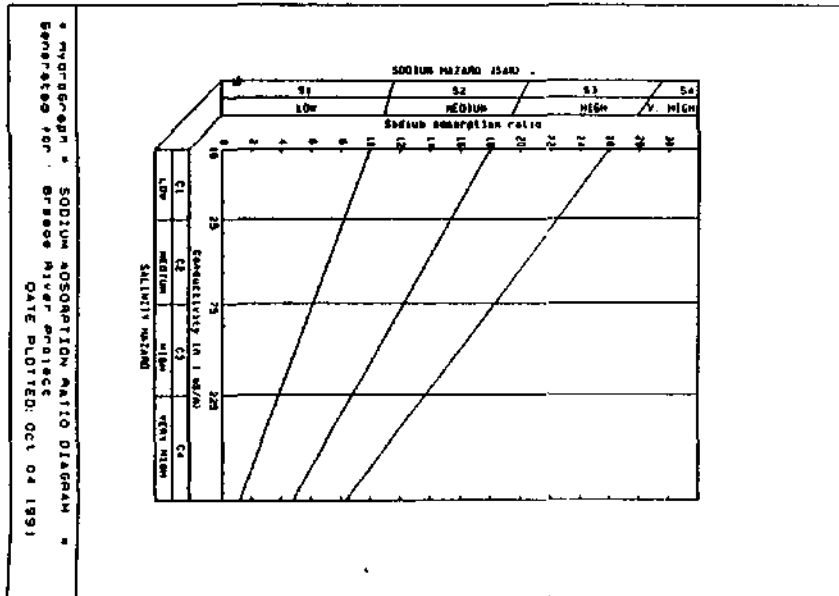
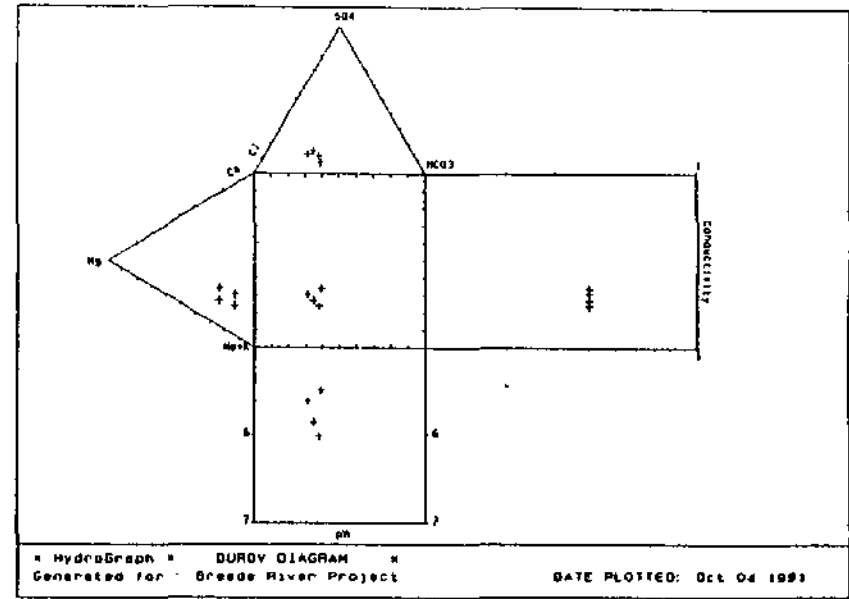
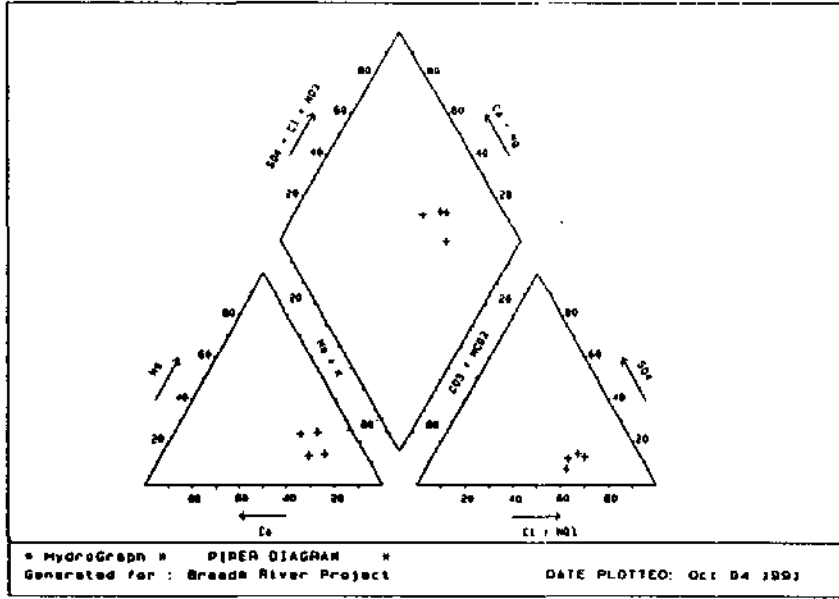

TMS : 3319DA00007

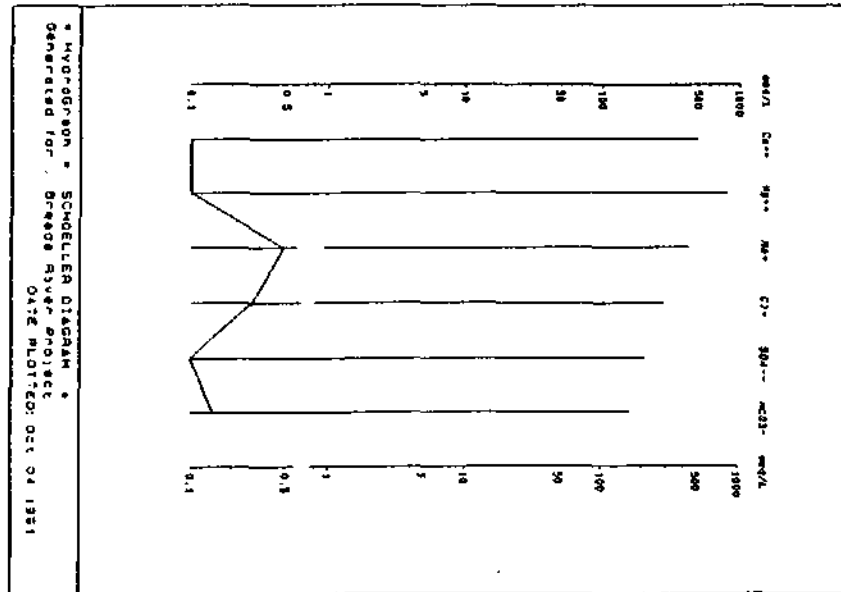
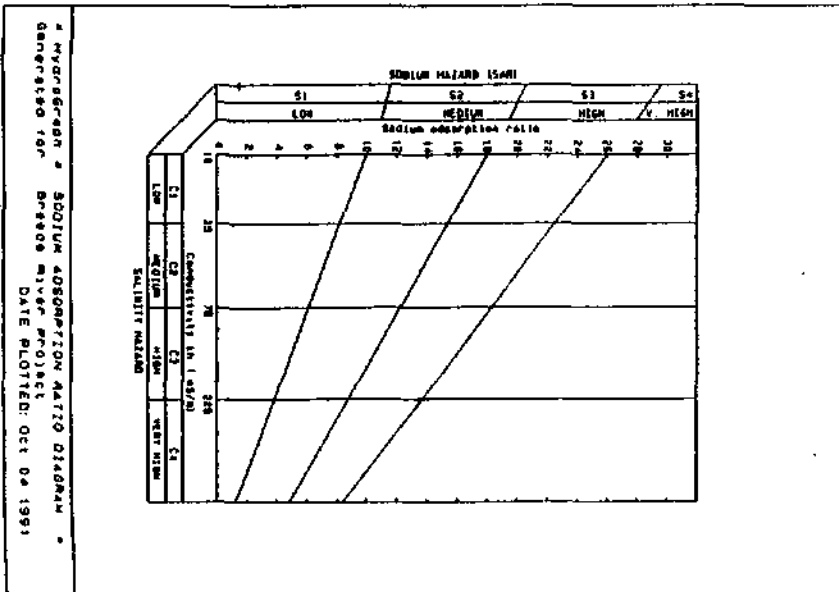
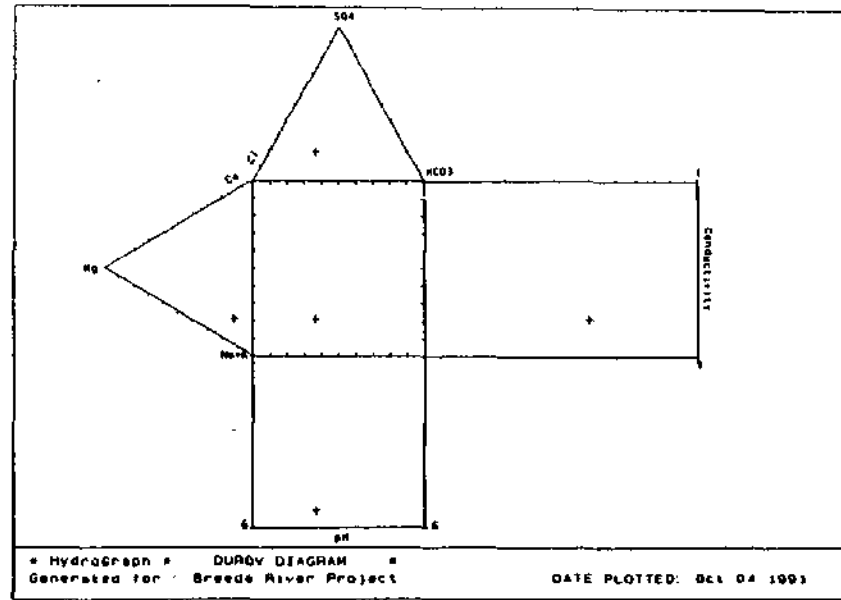
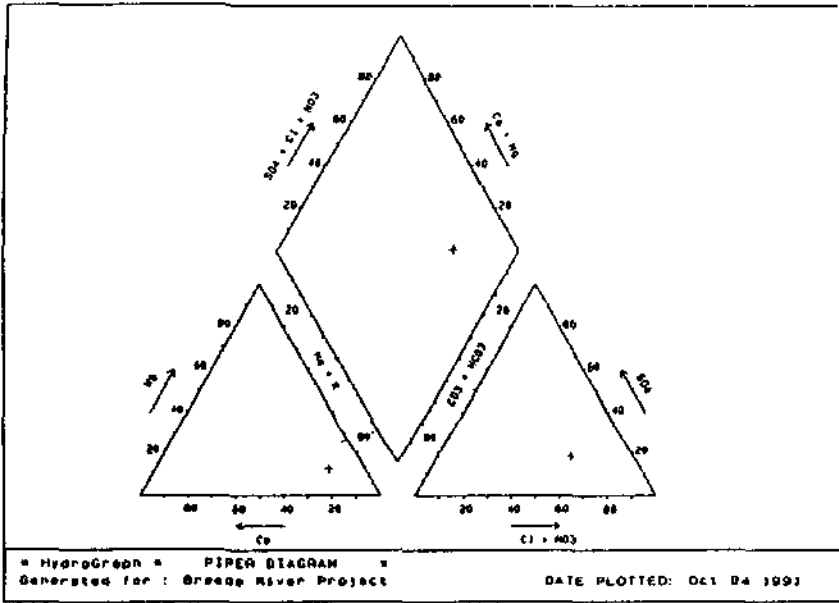

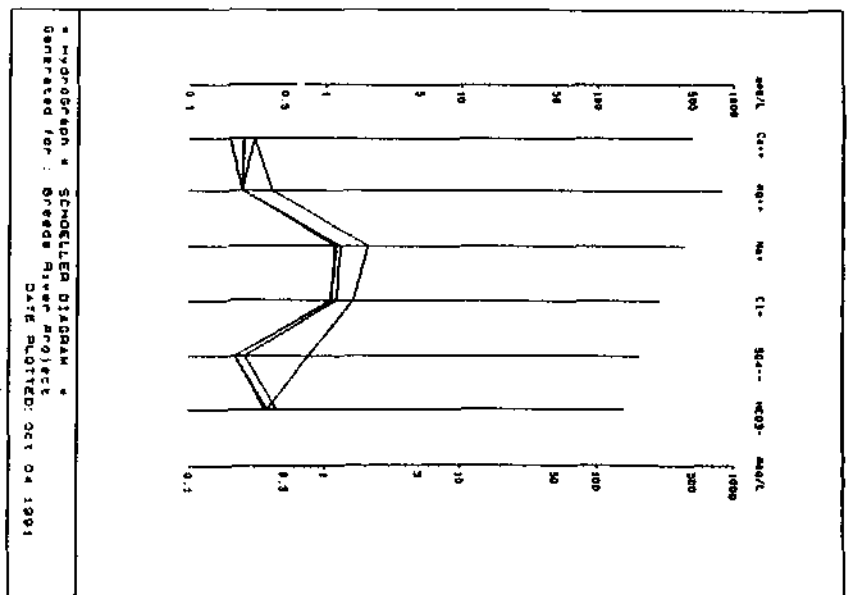
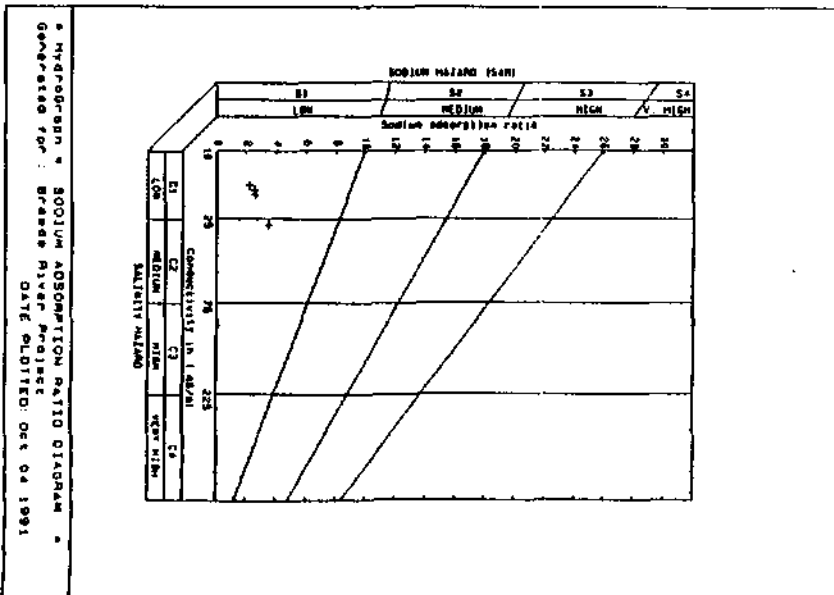
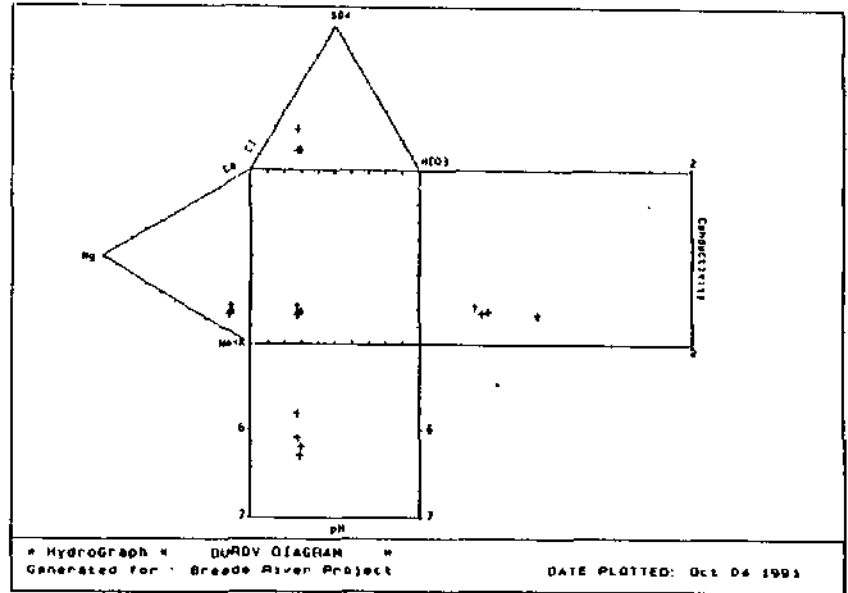
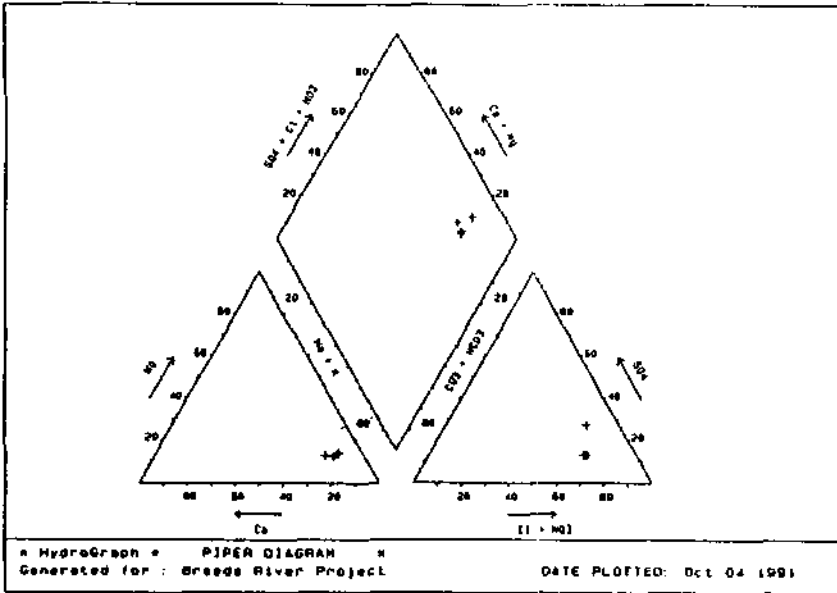

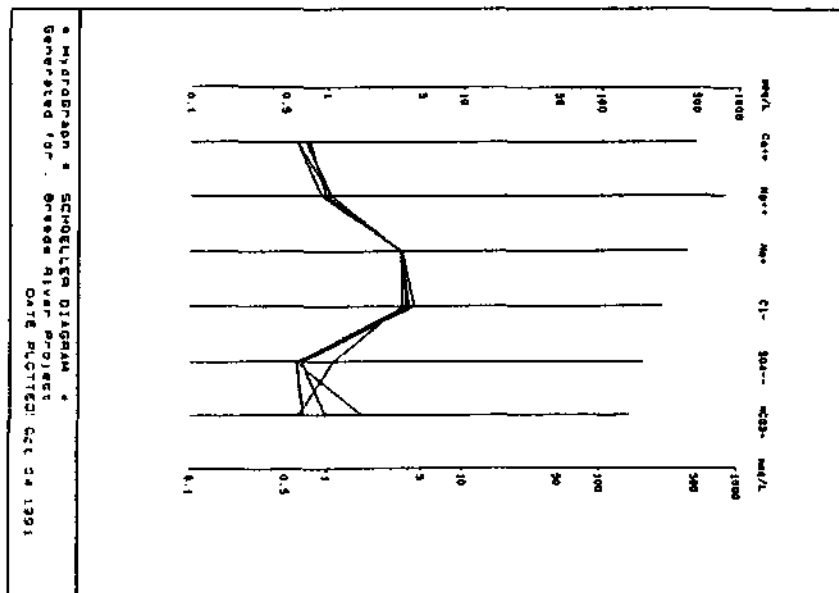
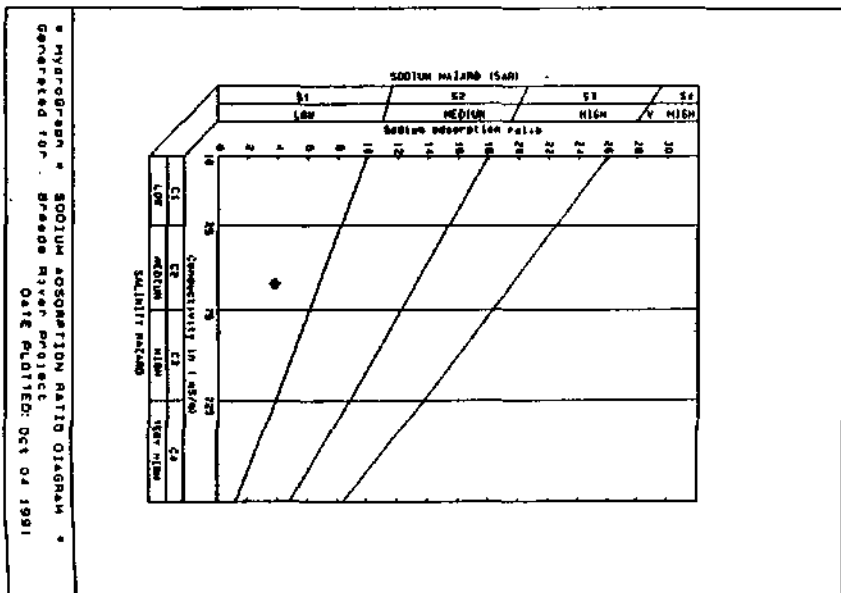
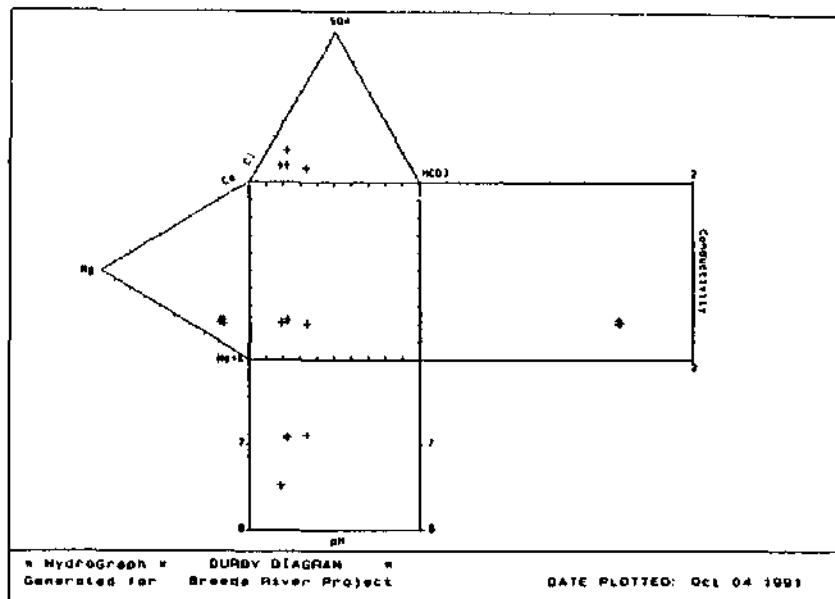
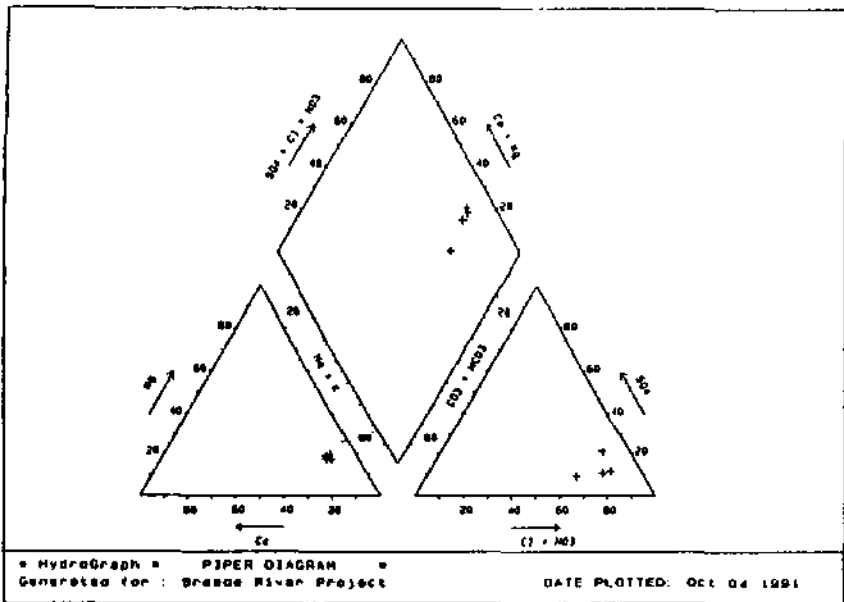

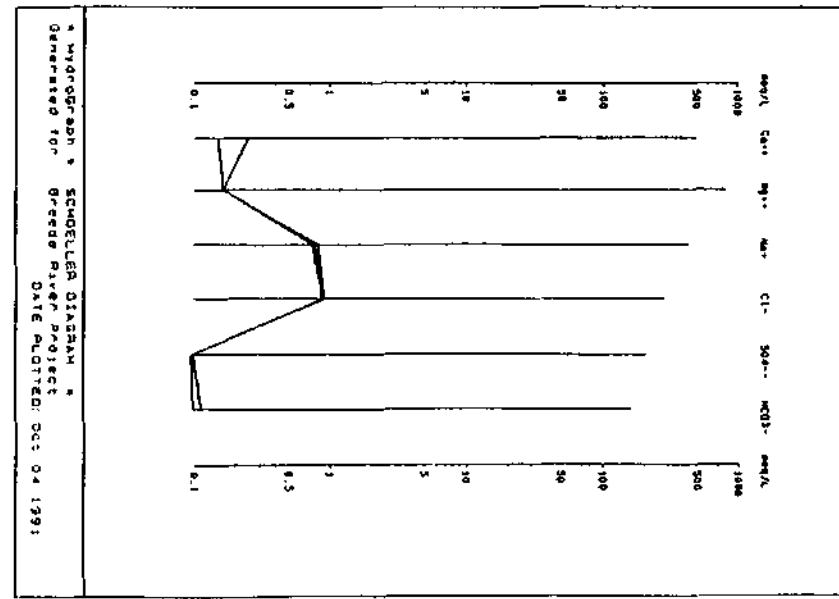
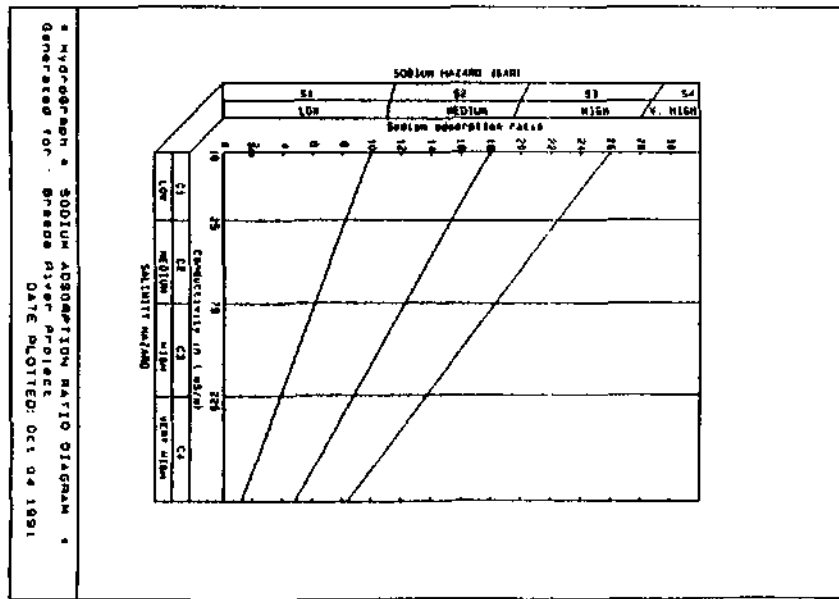
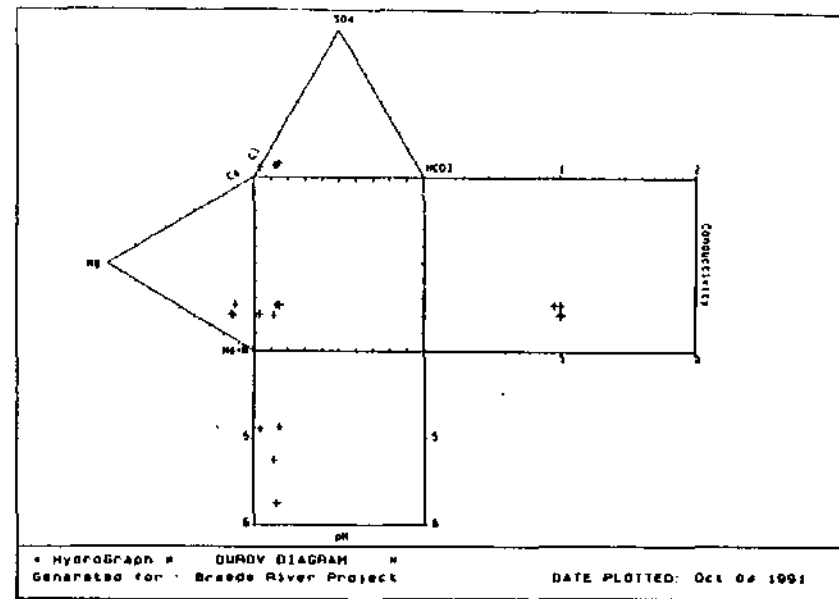
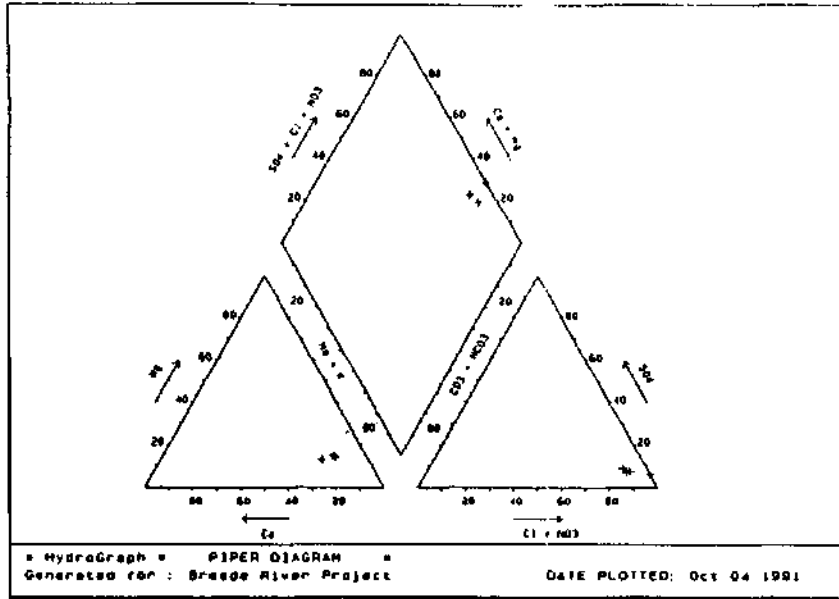

TMS : 3319DC00030

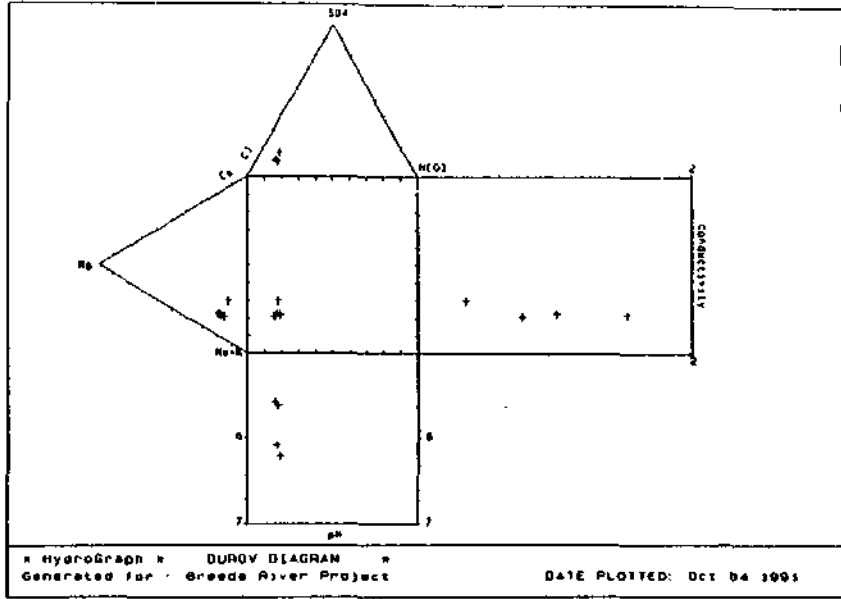
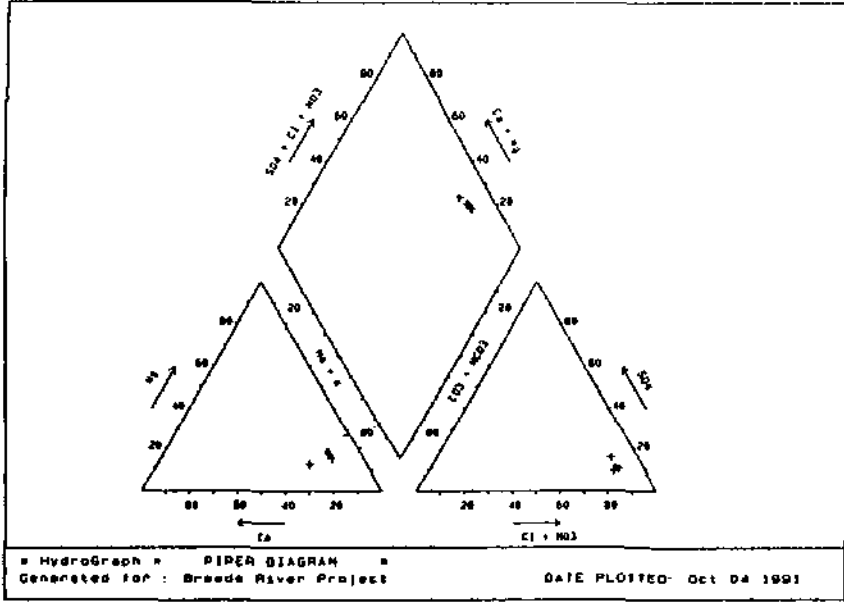

226

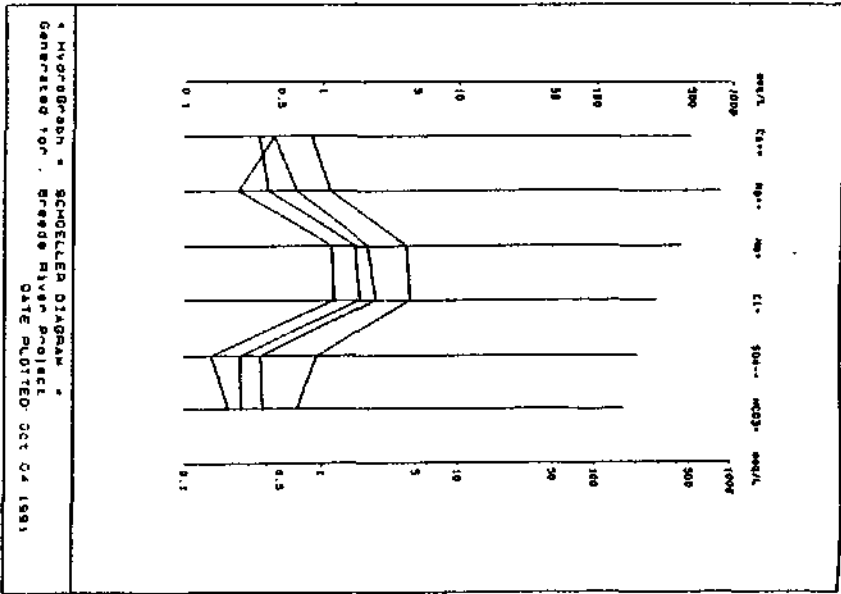
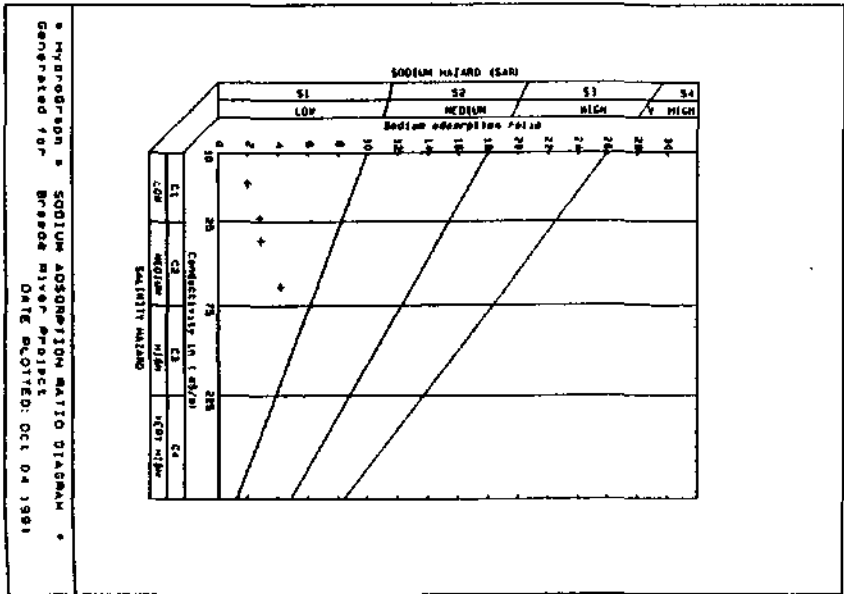

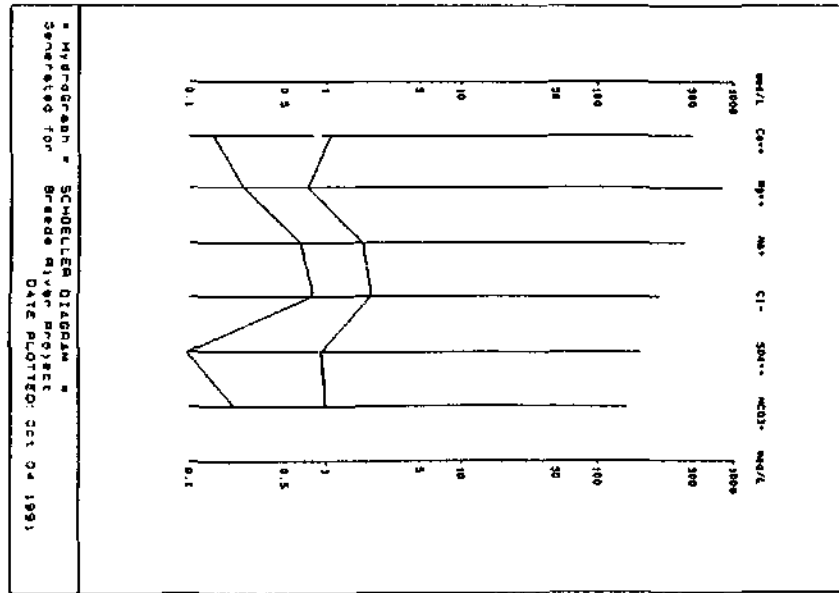
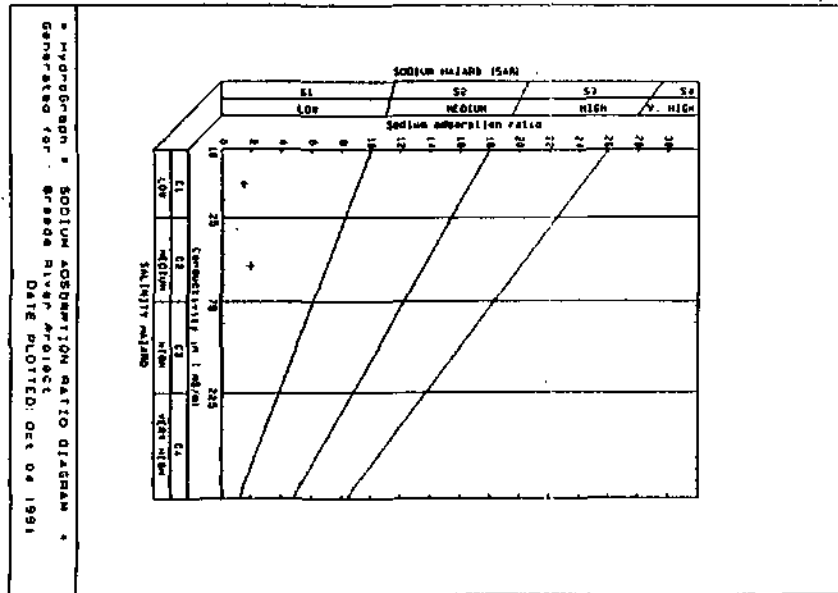
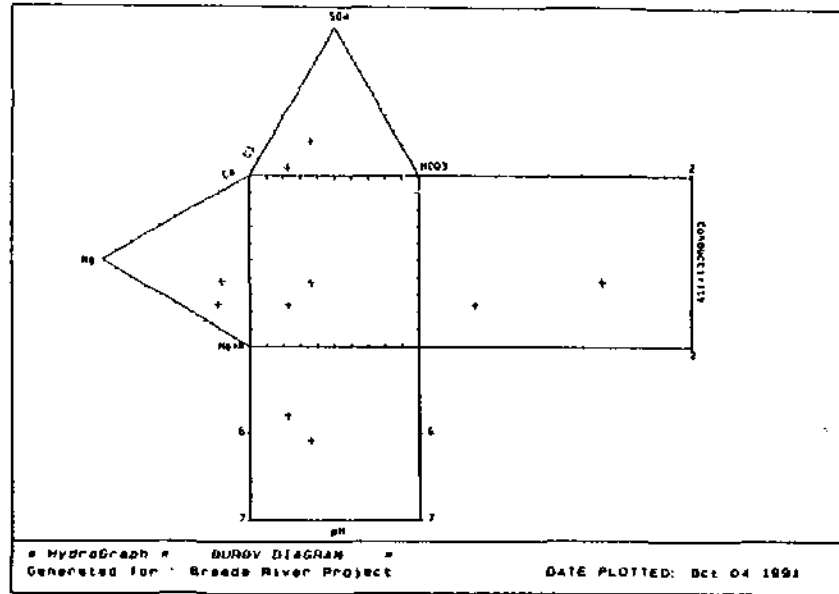
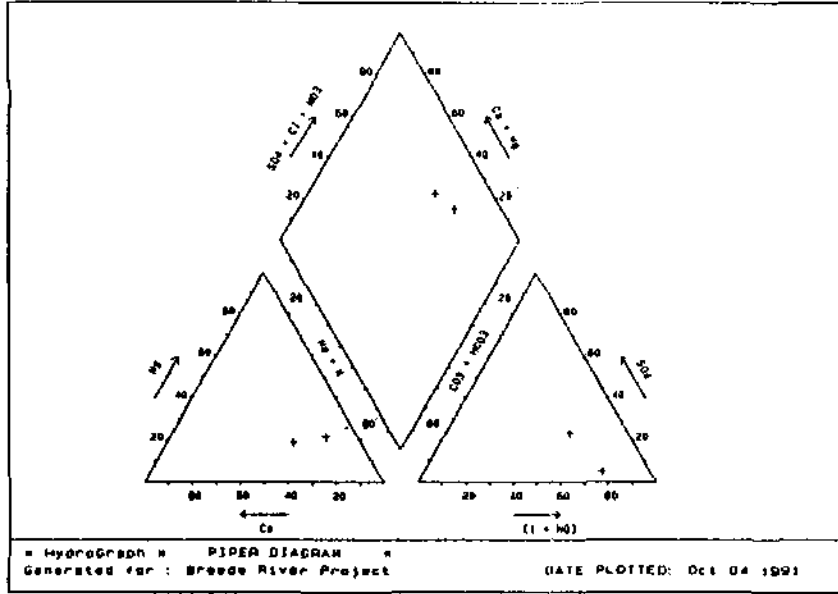

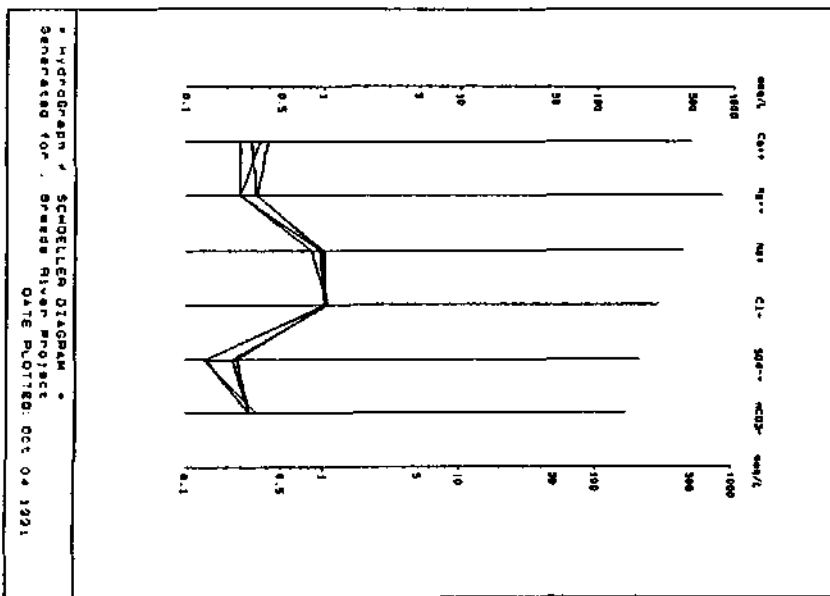
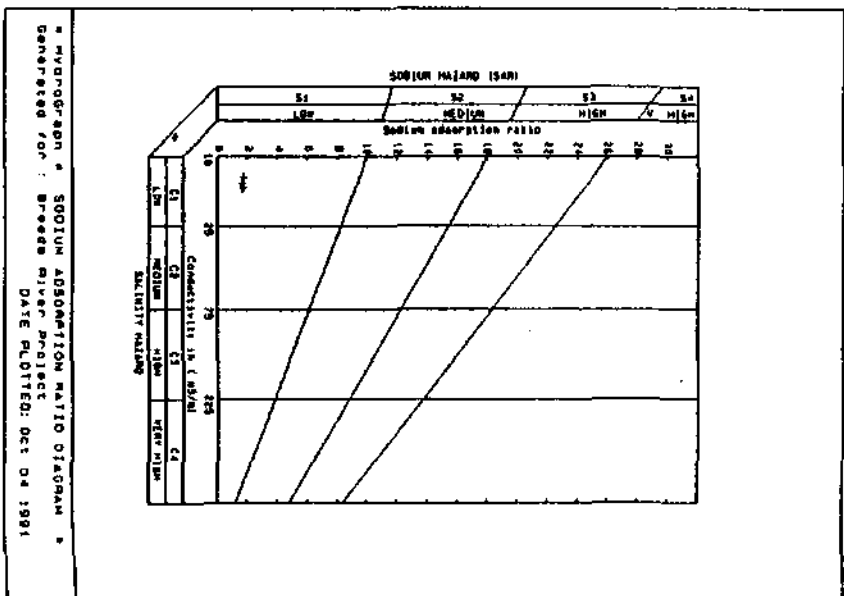
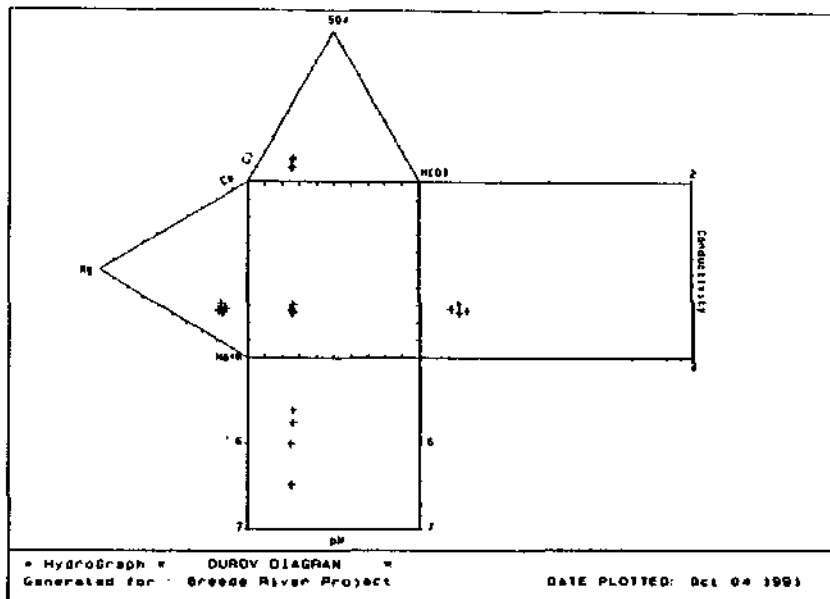
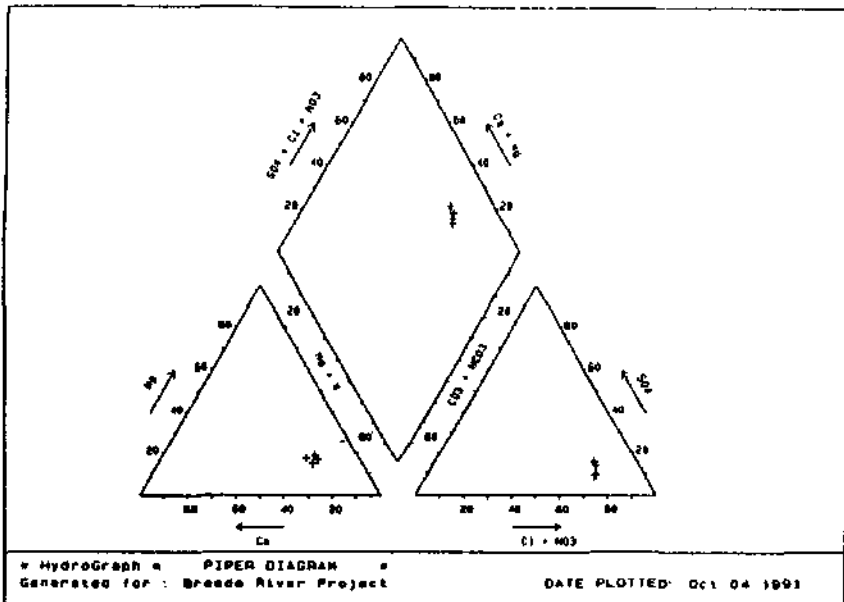

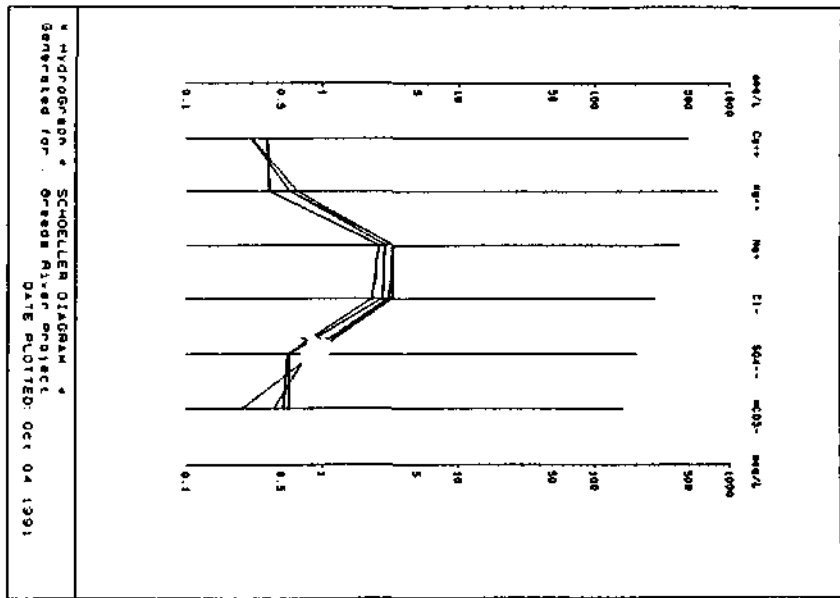
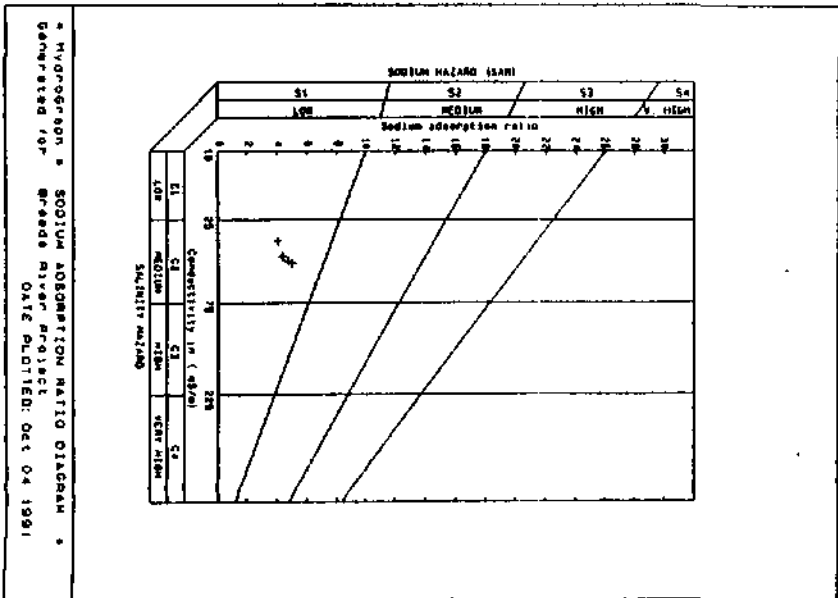
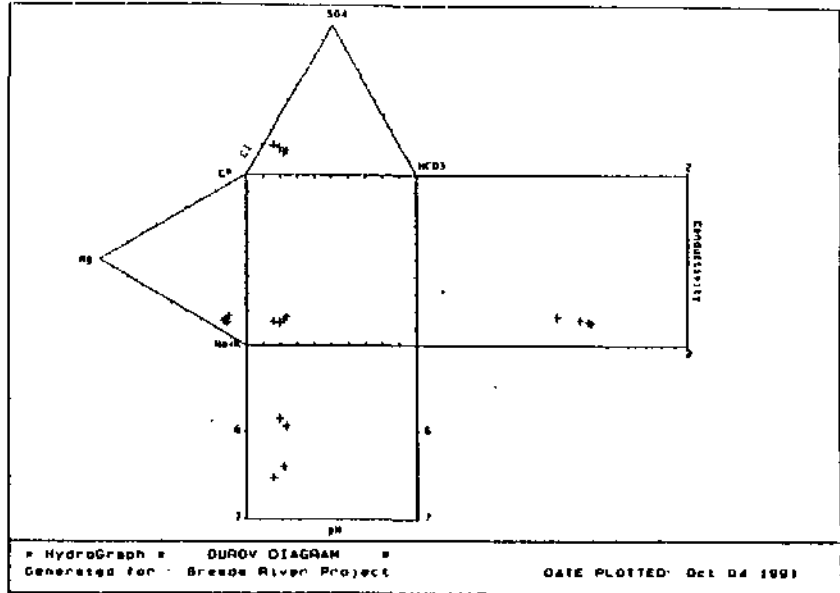
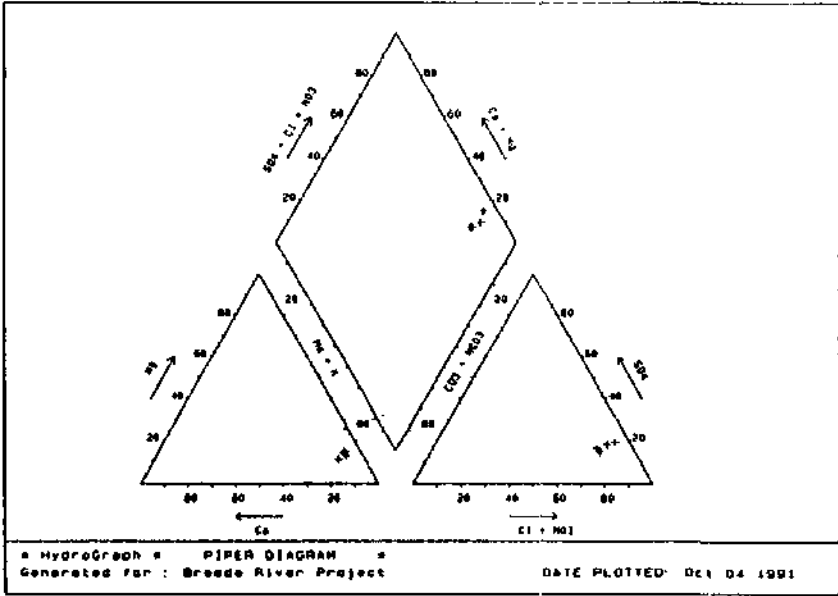

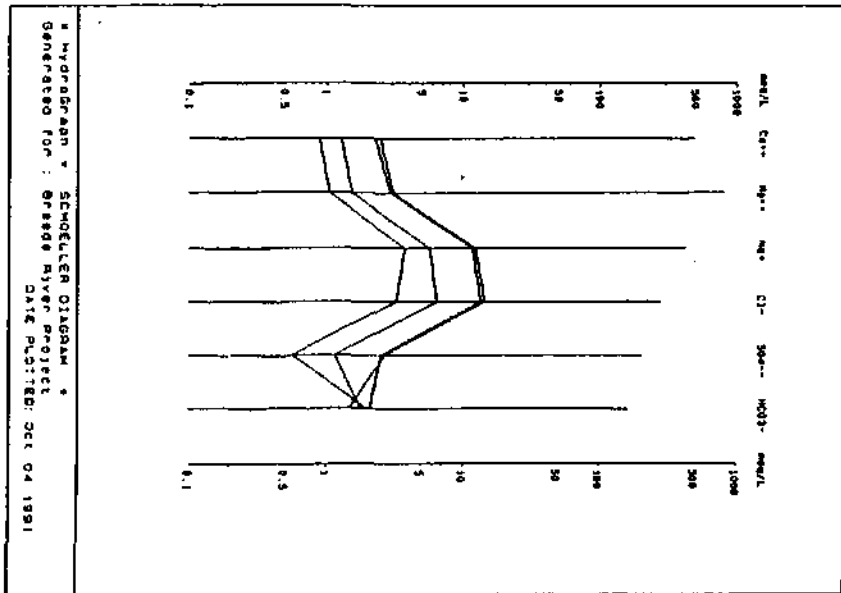
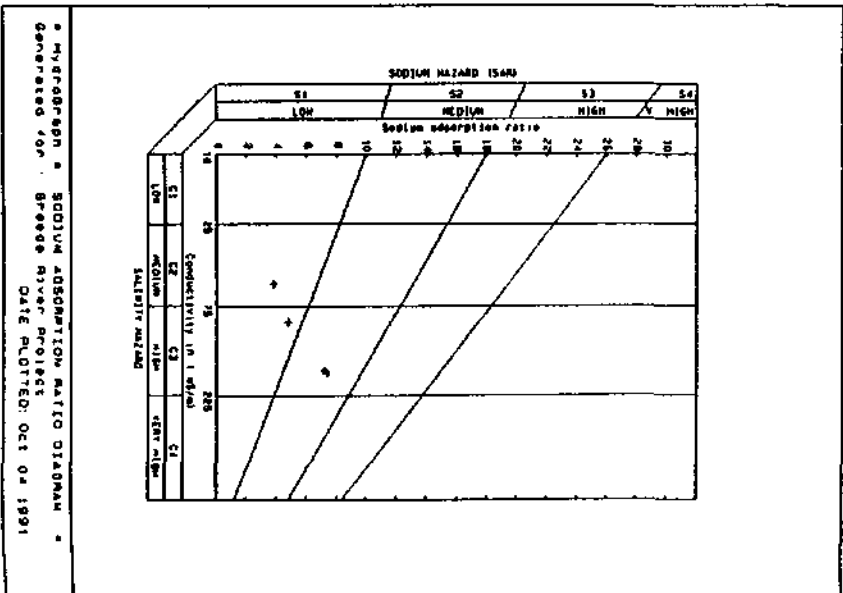
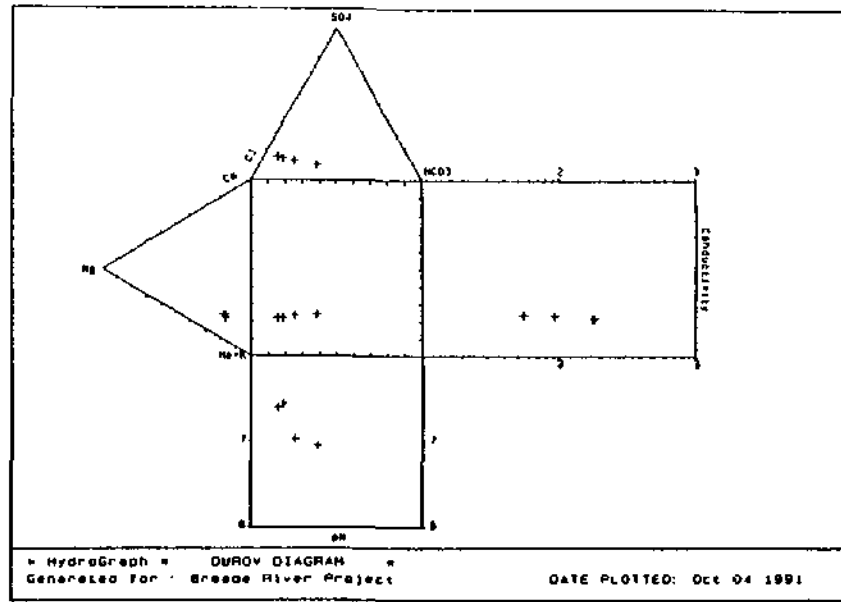
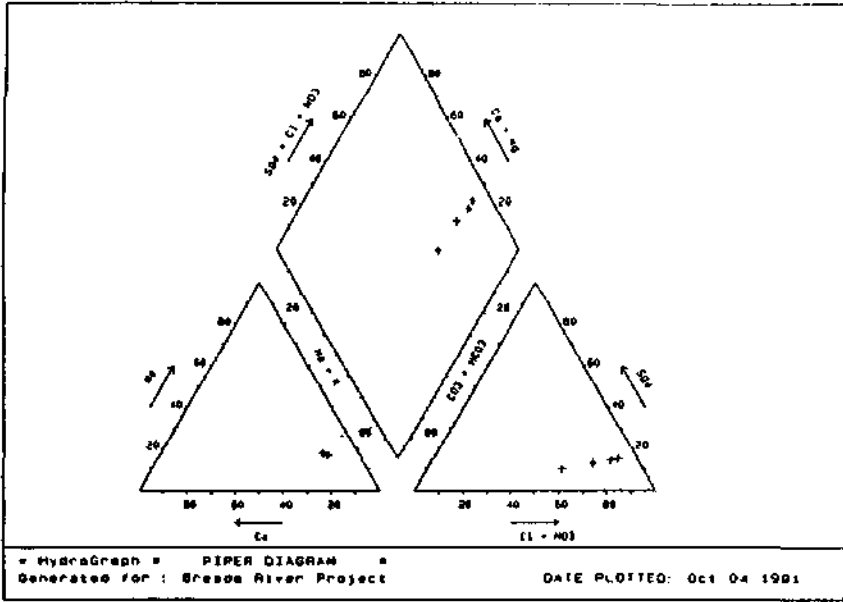

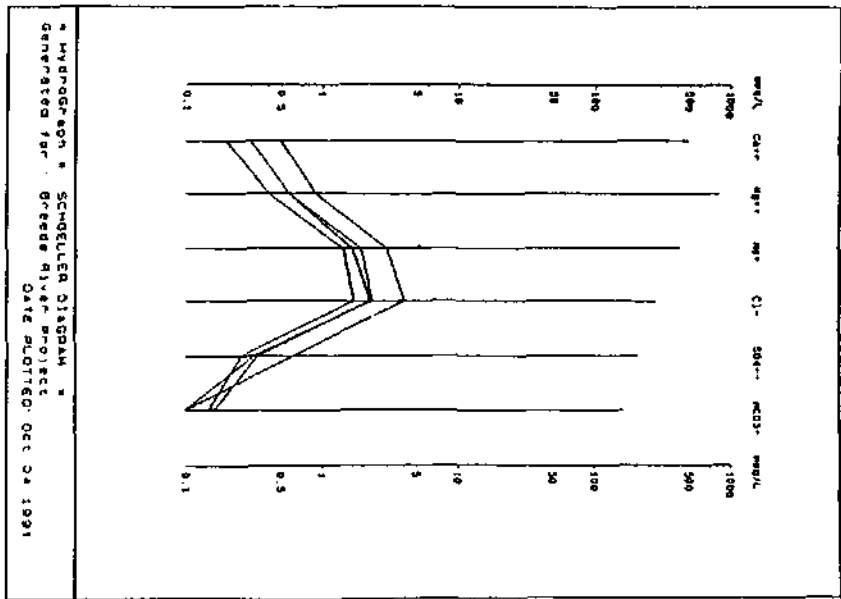
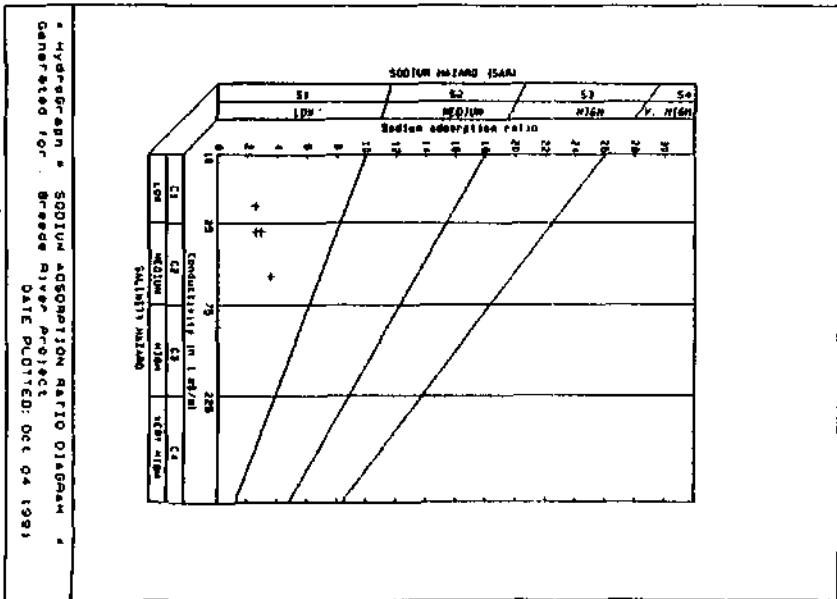
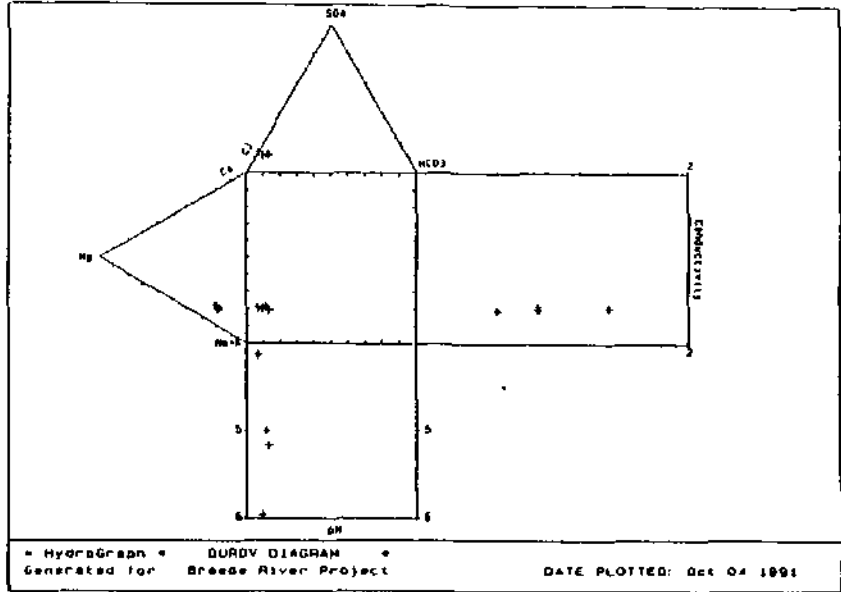
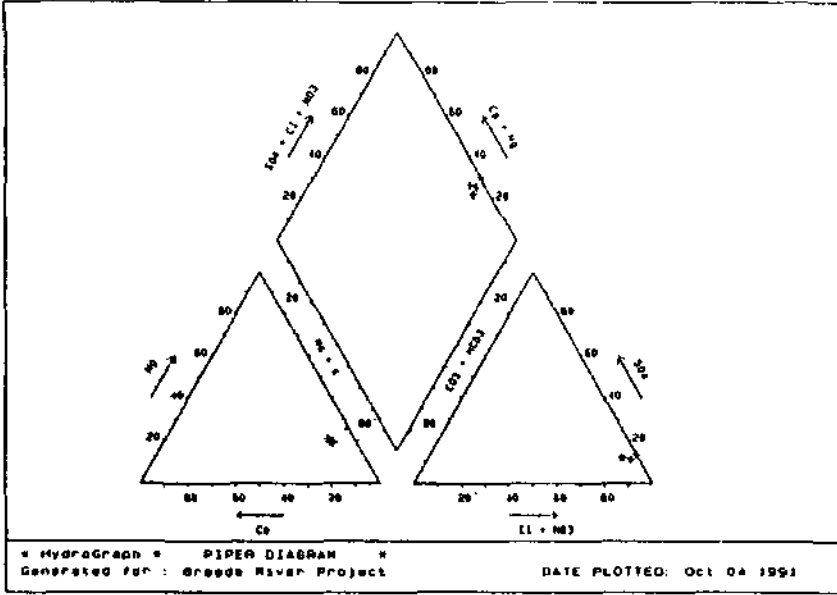

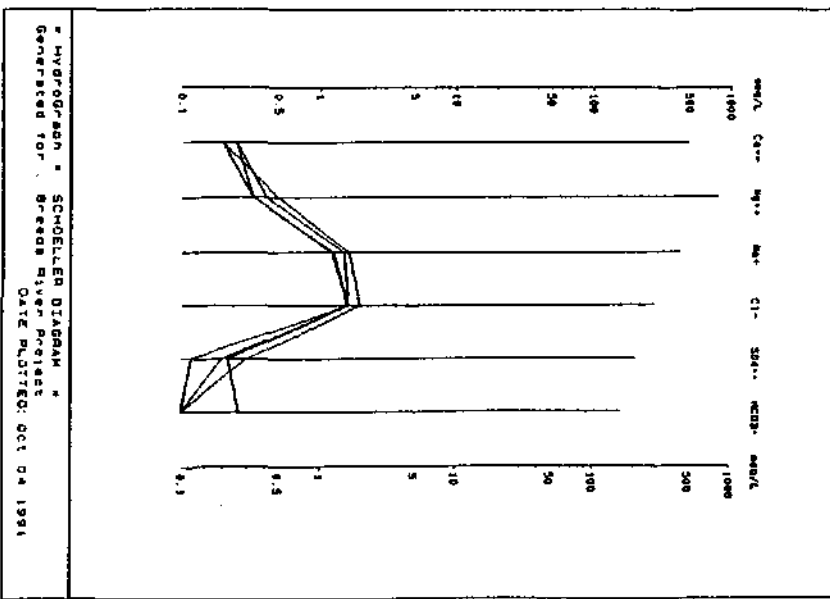
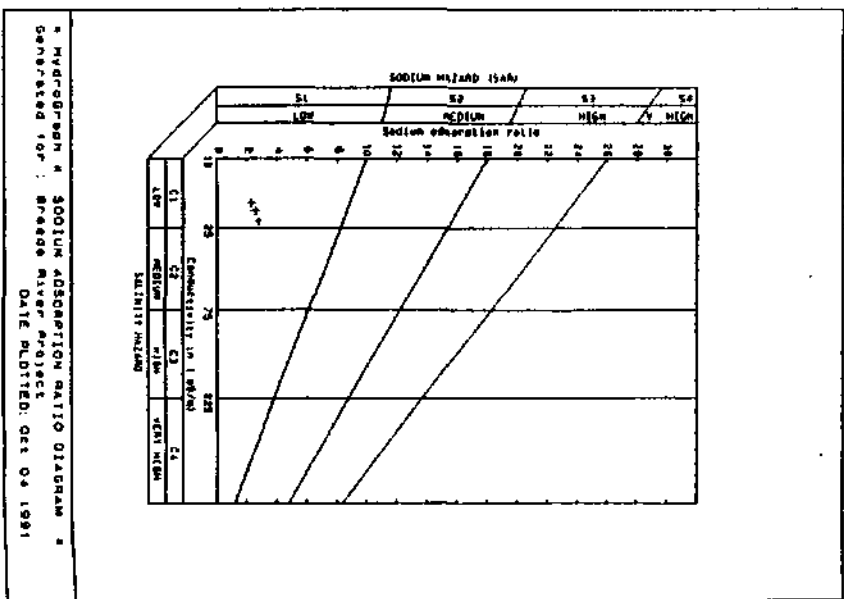
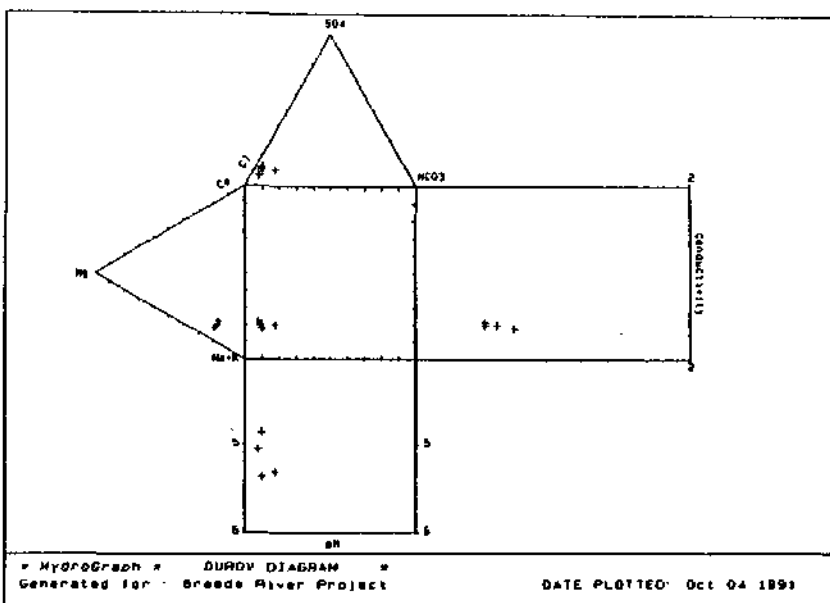
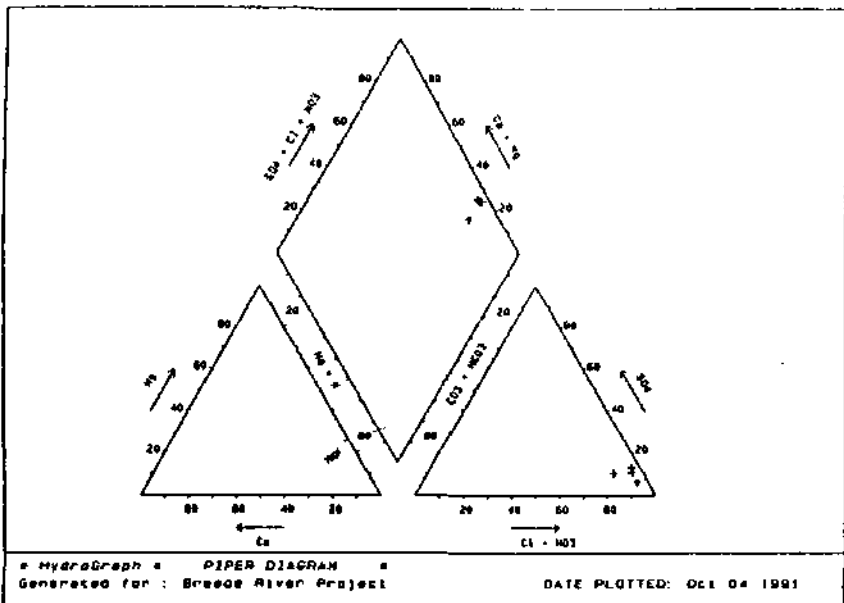

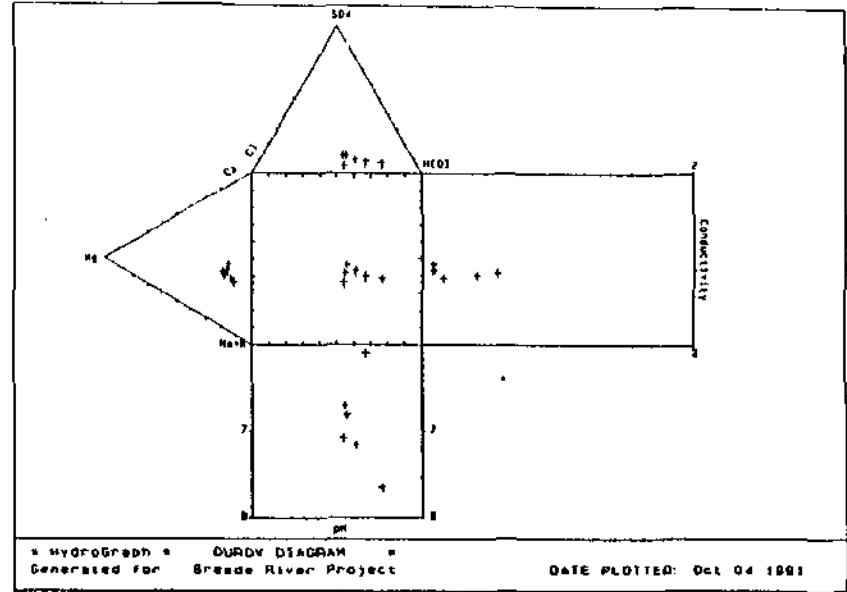
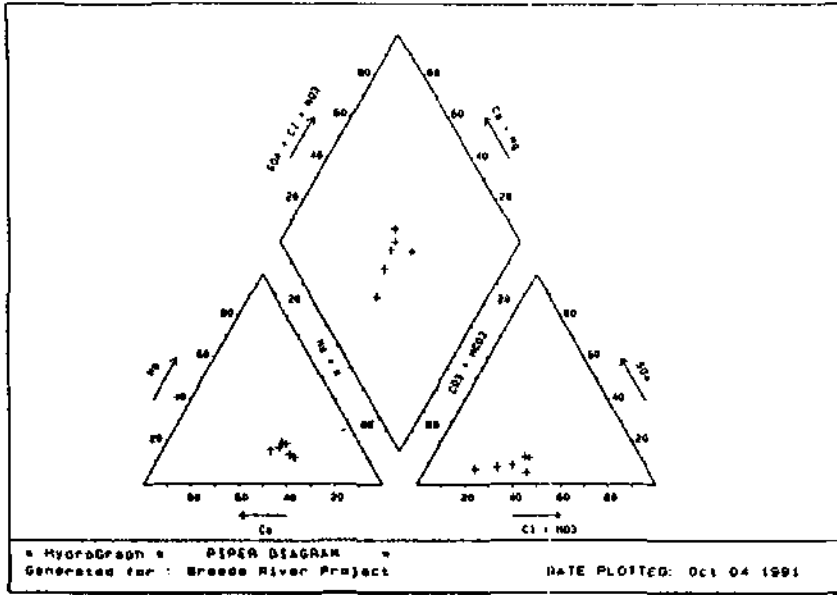

233

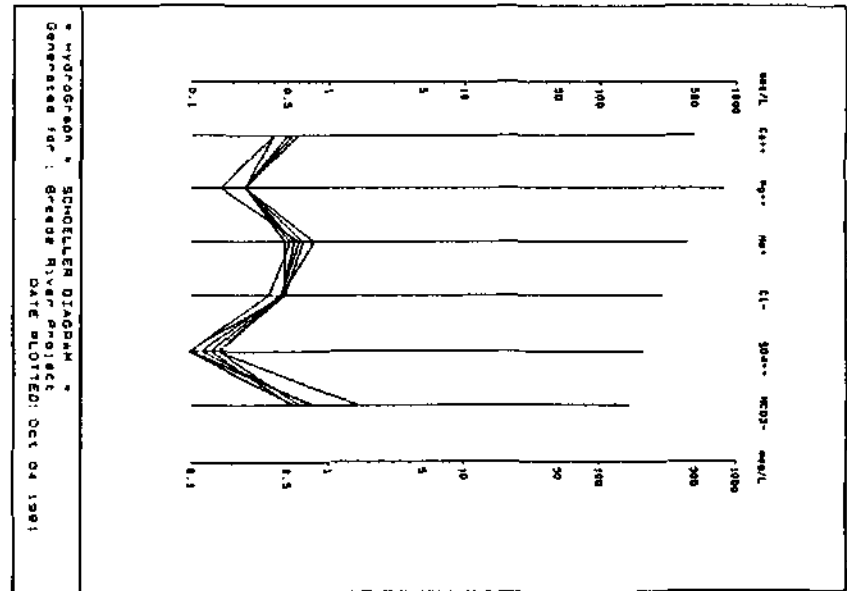
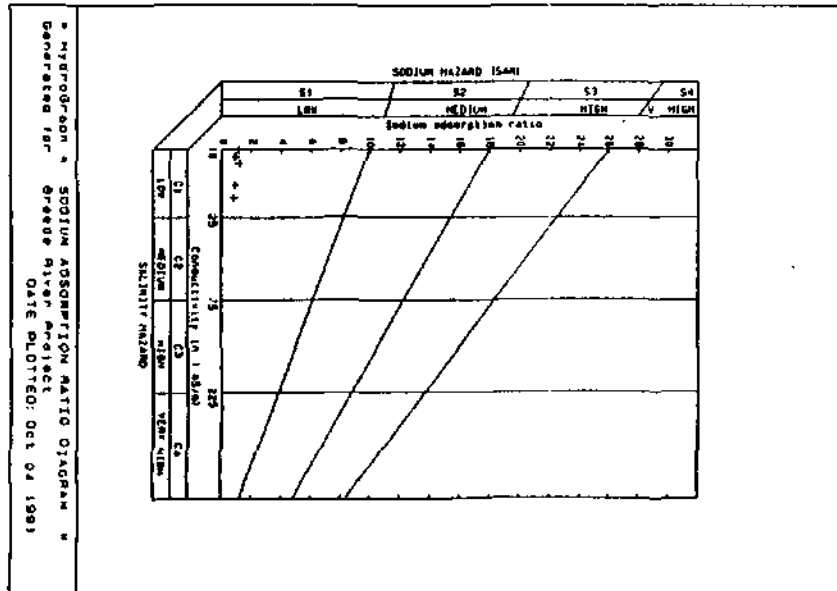

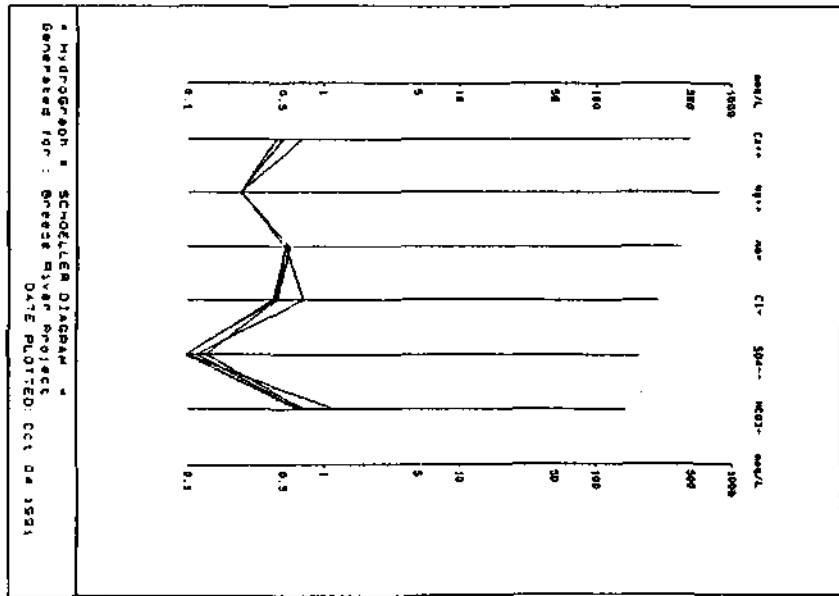
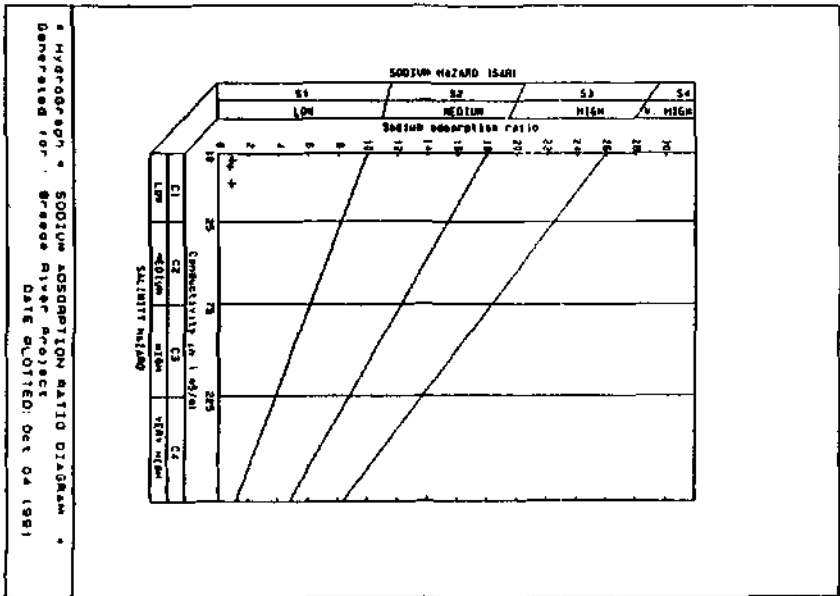
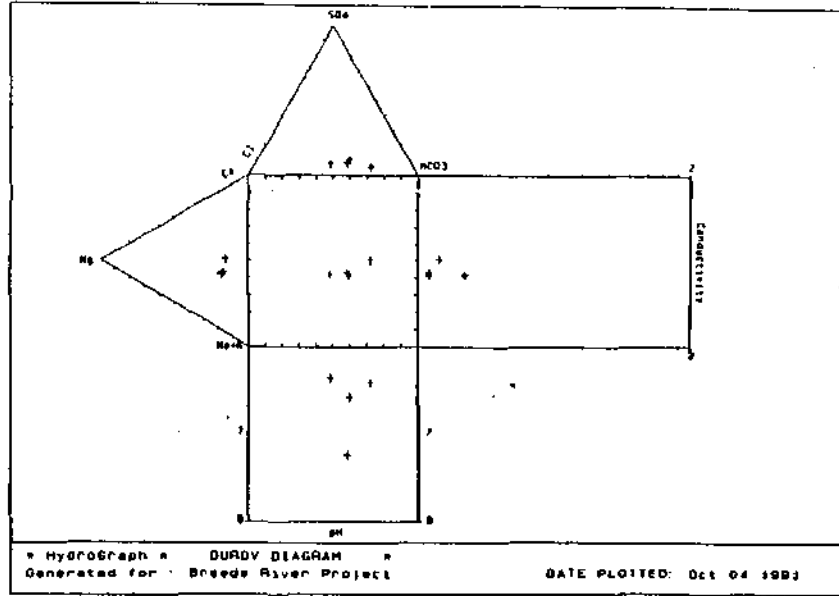
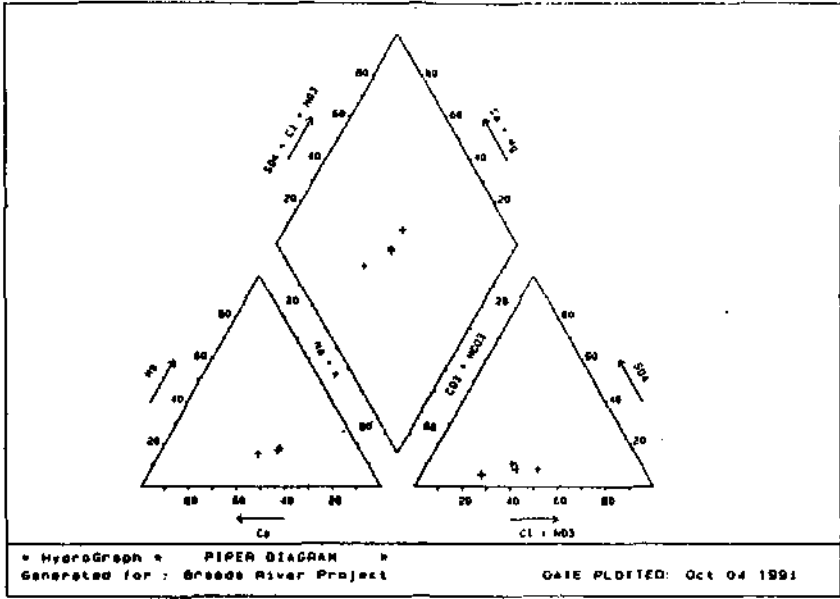

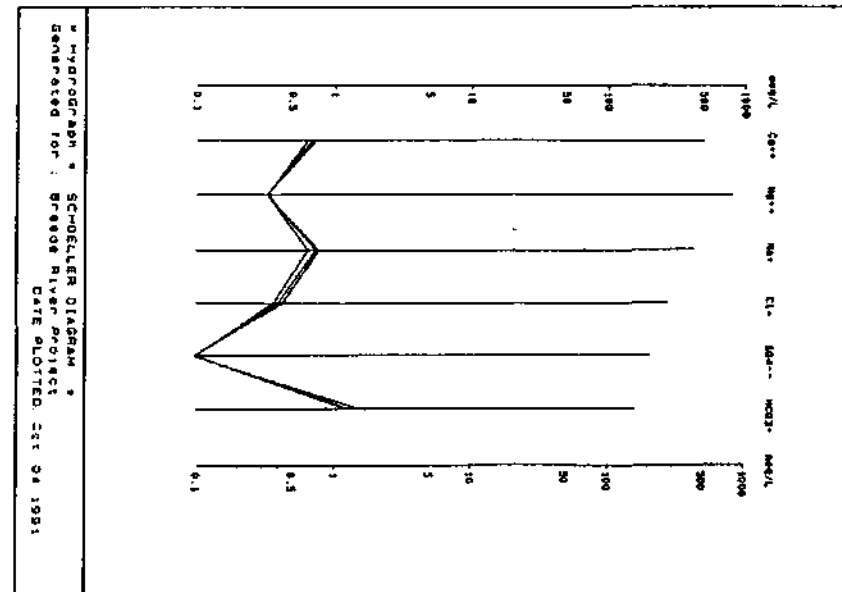
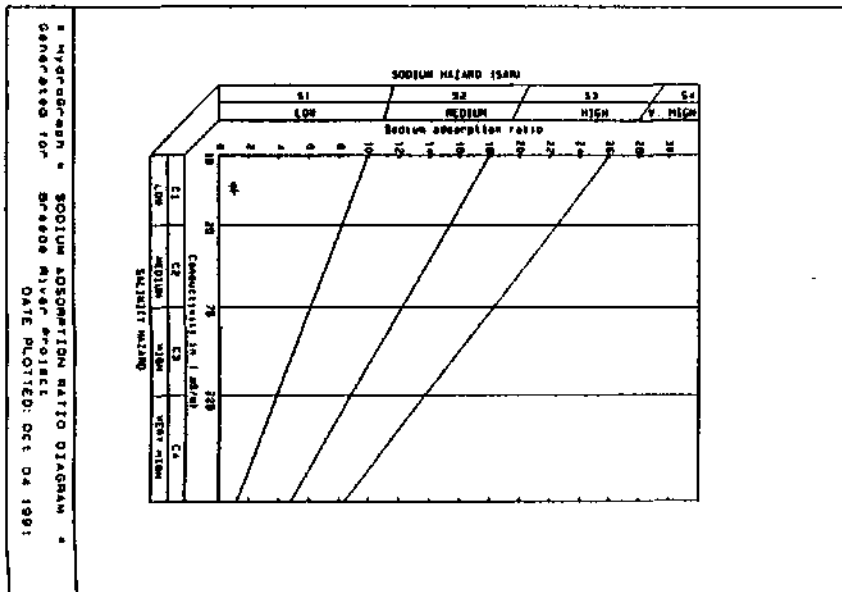
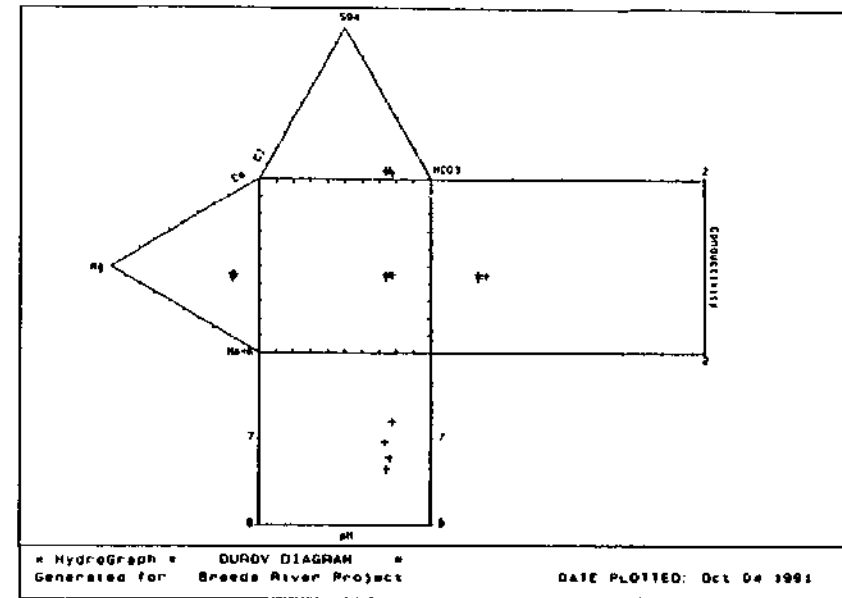
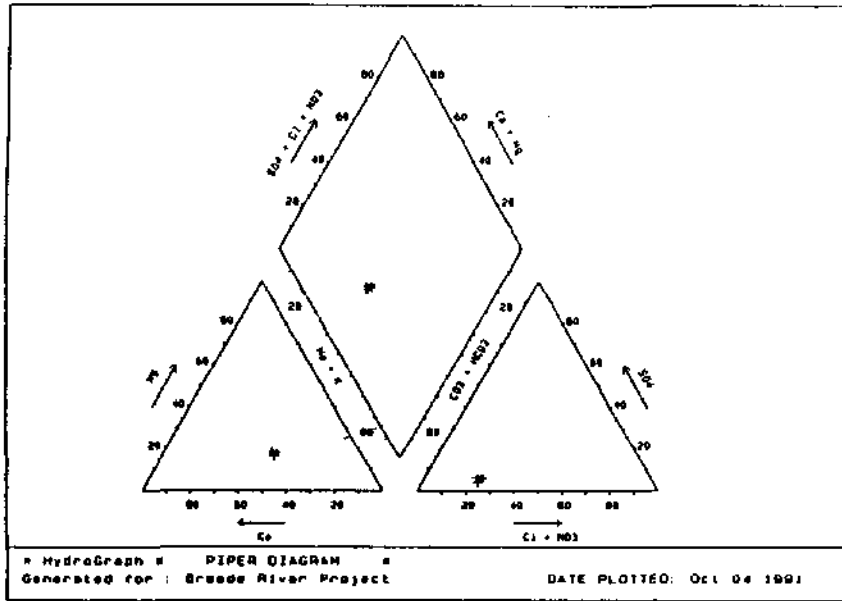

Appendix 9

Hydrochemical graphs:
Bokkeveld Group

 * HydroBase * User Defined Report * Date printed : 21 October 1991
 Generated for : Breede River Project
 Date range : 19000101 to 19991231 * Site range : Bokkeveld Group

 Data from file BASICINF :

SITE_ID_NR	NR_ON_MAP	SITE_NAME	SITE_TYPE	DEPTH
3319DC00007	DN07	DE FONTEIN, Agterkliphoogte Wynkelder	Borehole	91.00
3319DC00008	DN08	DE FONTEIN: BELLEVUE	Borehole	100.00
3319DC00010	PR01	POESJENELSRIVIER: GOODHOPE	Borehole	45.00
3319DC00037	RY08	RIETVALLY:WEEK-EN-RUS	Borehole	91.00
3319DC00039	RY10	RIETVALLY	Borehole	122.00
3319DC00107	AB	GNOEM GNOEMS	Fountain	0.00
3319DD00001	G33570	OVER HET ROODEZAND 112	Borehole	80.00
3319DD00005	G33573	OVER HET ROODEZAND 112	Borehole	80.00
3319DD00006	G33574	GOEDE MOED 128	Borehole	80.00
3319DD00008	G33576	GOEDE MOED 128	Borehole	80.00
3319DD00009	G33577	GOEDE MOED 128	Borehole	80.00
3319DD00010	G33578	GOEDE MOED 128	Borehole	80.00
3319DD00011	G33579	UITNOOD 129	Borehole	80.00
3319DD00012	G33580	UITNOOD 129	Borehole	80.00
3319DD00016	G33584	OVER HET ROODEZAND 112	Borehole	80.00
3319DD00020	G33588	UITNOOD 129	Borehole	100.00
3319DD00021	G33589	GOEDE MOED 128	Borehole	100.00
3319DD00022	G33590	OVER HET ROODEZAND 112	Borehole	80.00
3319DD00023	G33591	OVER HET ROODEZAND 112	Borehole	80.00
3319DD00024	G33592	OVER HET ROODEZAND 112	Borehole	80.00
3319DD00033	G201	GOREE'S HOOGTE - MADEBA	Borehole	73.00
3319DD00042	MD07	McGREGOR, Uitvlug, on right bank of Boekriver	Borehole	91.00
3319DD00043	MD08	MC GREGOR TOEKENNINGSGBIED - RHEBOKSKRAAL	Borehole	122.00
3319DD00053	RL01	RHEBOKSKRAAL	Borehole	0.00
3319DD00058	VD02	VROLYKHEID - THORNVILLA	Borehole	98.00
3319DD00059	VD03	VROLYKHEID - THORNVILLA	Borehole	110.00
3319DD00060	VD04	VROLYKHEID - MC GREGOR WYNKELDER	Borehole	50.00
3319DD00067	ZNO2	ZAND BERG FONTEIN - SANDBERG	Borehole	18.90
3319DD00109	B5	DOORN KLOOF, Vrolijkheid Nature Reserve	Borehole	0.00
3319DD00125	N	DIE GHWARRIES, ca. 30 m W of ruin.	Borehole	0.00
3319DD01593	G33593		Borehole	71.00
3319DD01596	G33596		Borehole	80.00
3319DD01598	G33598		Borehole	27.00
3319DD01599	G33599		Borehole	9.00
3319DD01600	G33600		Borehole	80.00
3319DD01601	G33601		Borehole	80.00
3319DD01602	G33602		Borehole	80.00
3319DD01603	G33603		Borehole	0.00
3319DD01605	G33605		Borehole	80.00
3319DD01606	G33606		Borehole	80.00
3319DD01607	G33607		Borehole	80.00
3319DD01608	G33608		Borehole	16.00
3319DD01609	G33609		Borehole	15.00
3319DD01610	G33610		Borehole	10.00
3319DD01611	G33611		Borehole	10.00
3319DD02573	G33573A		Borehole	0.00
3319DD02574	G33574A		Borehole	22.00
3319DD02576	G33576A		Borehole	25.00
3319DD02584	G33584A		Borehole	17.00
3319DD02590	G33590A		Borehole	13.00
3319DD02591	G33591A		Borehole	12.00
3319DD02592	G33592A		Borehole	12.00
3319DD02596	G33596A		Borehole	12.00
3319DD03591	G33591B		Borehole	44.00
3319DD04574	G33574C		Borehole	19.50
3319DD04584	G33584C		Borehole	28.00
3319DD04600	G33600C		Borehole	18.00

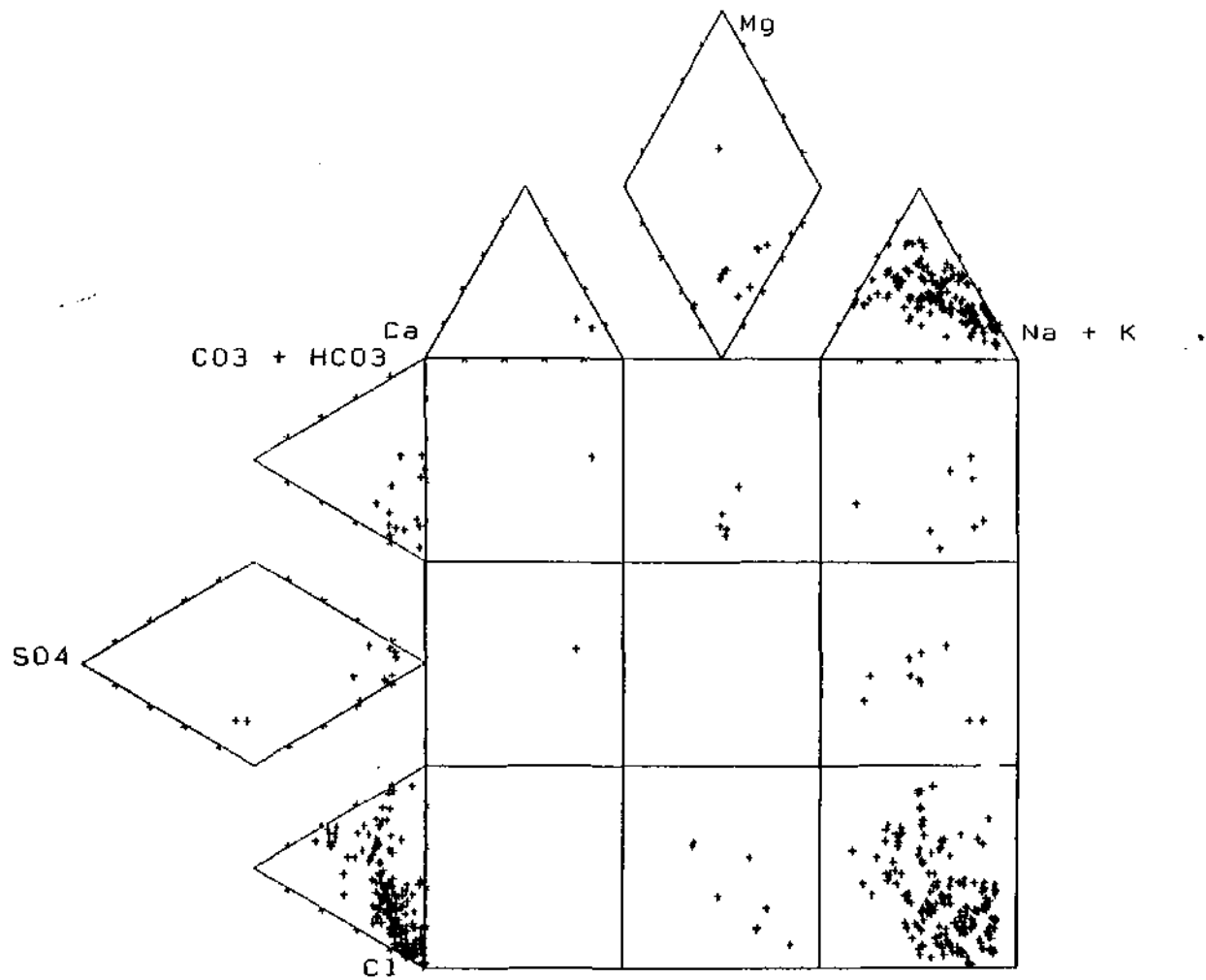

* HydroBase * EXPANDED DUROV DIAGRAM *
Generated for : Breede River Project

DATE PLOTTED: Oct 08 1991

BOKKEVELD

239

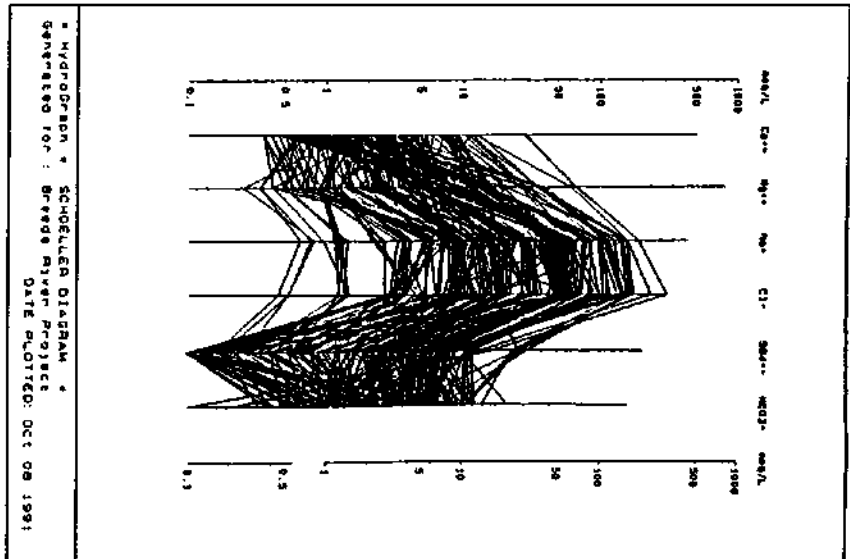
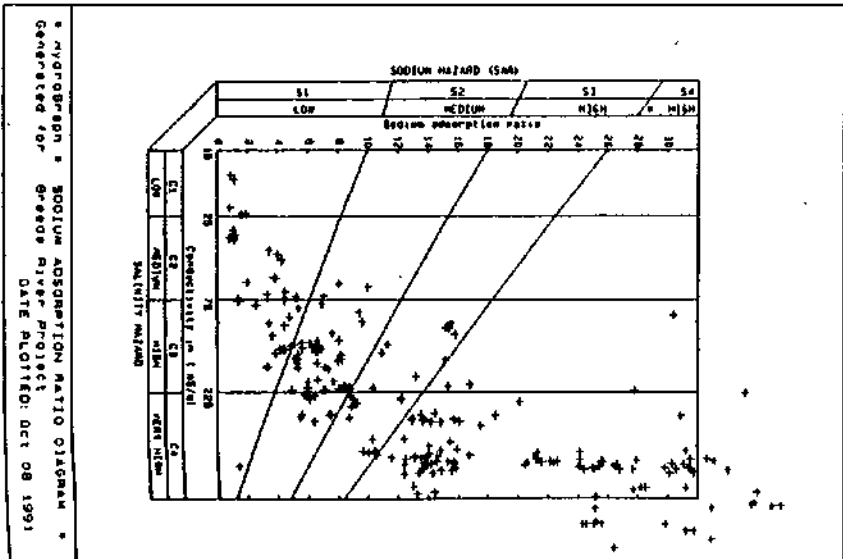
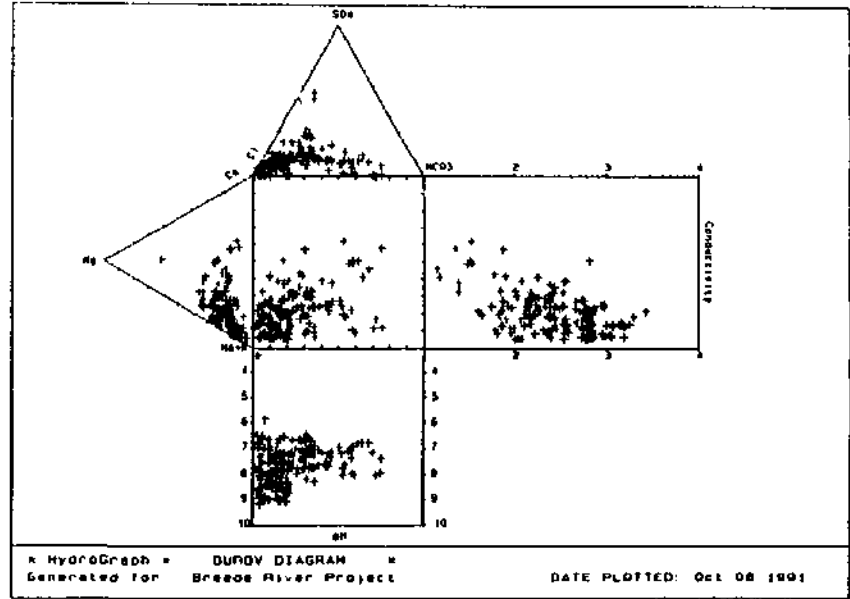
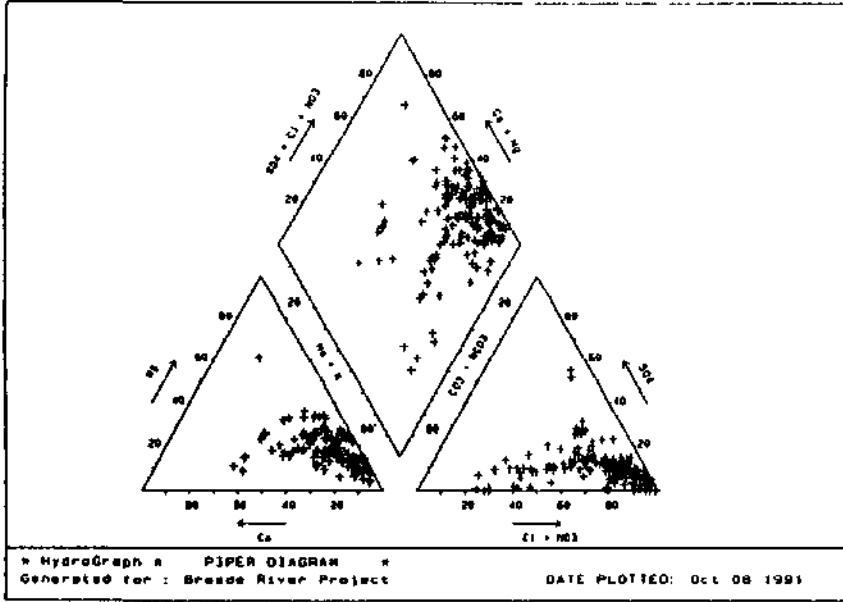

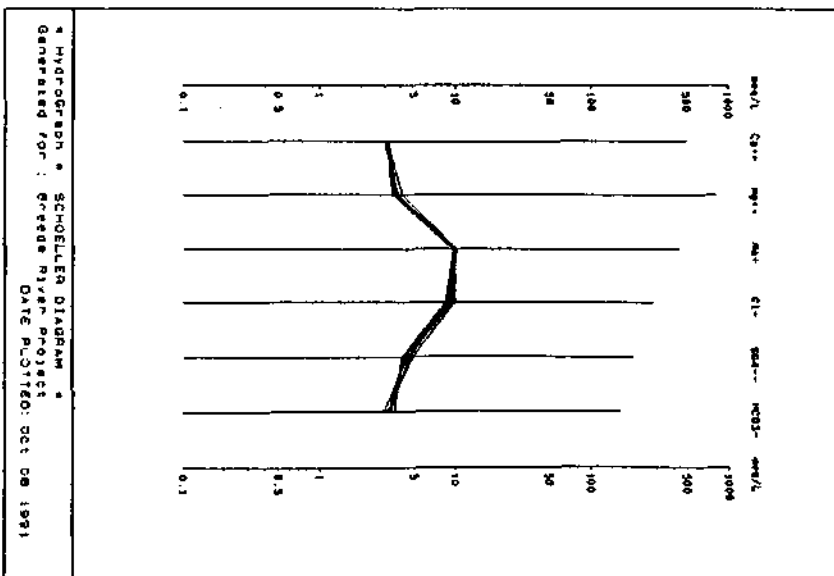
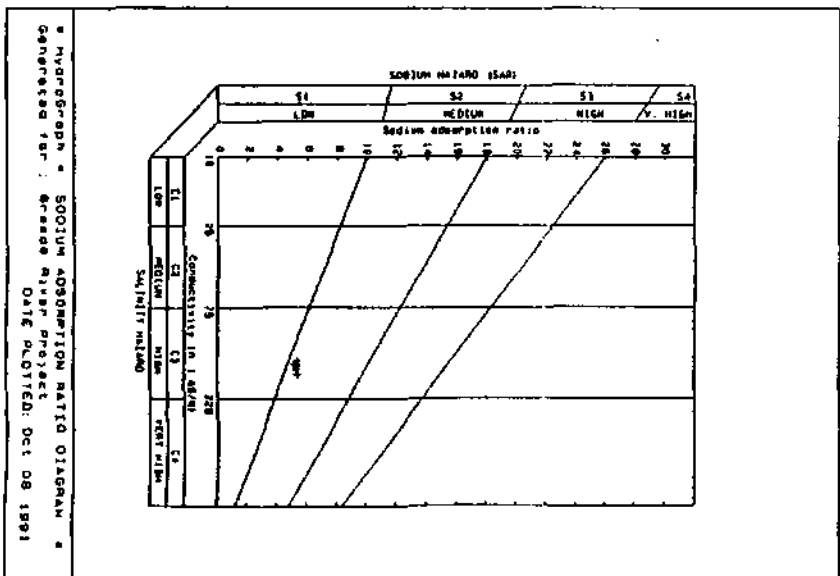
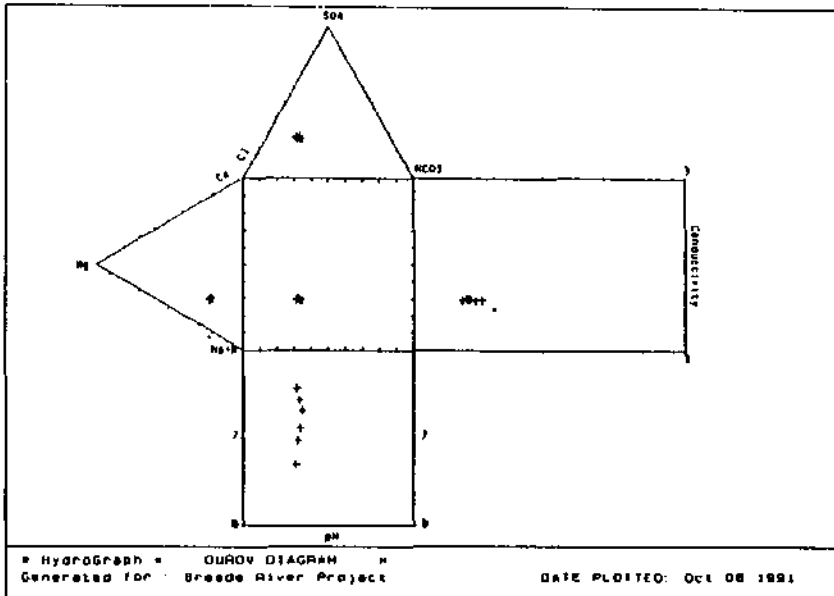
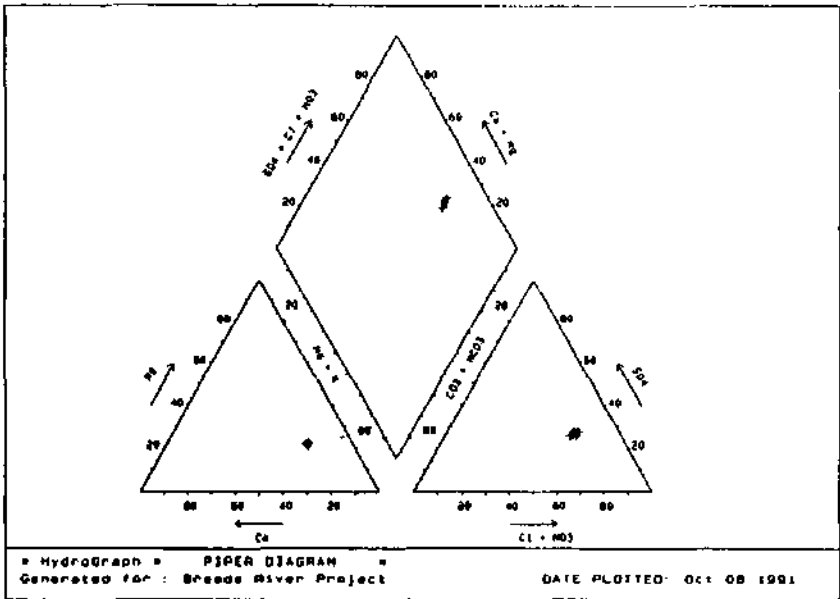

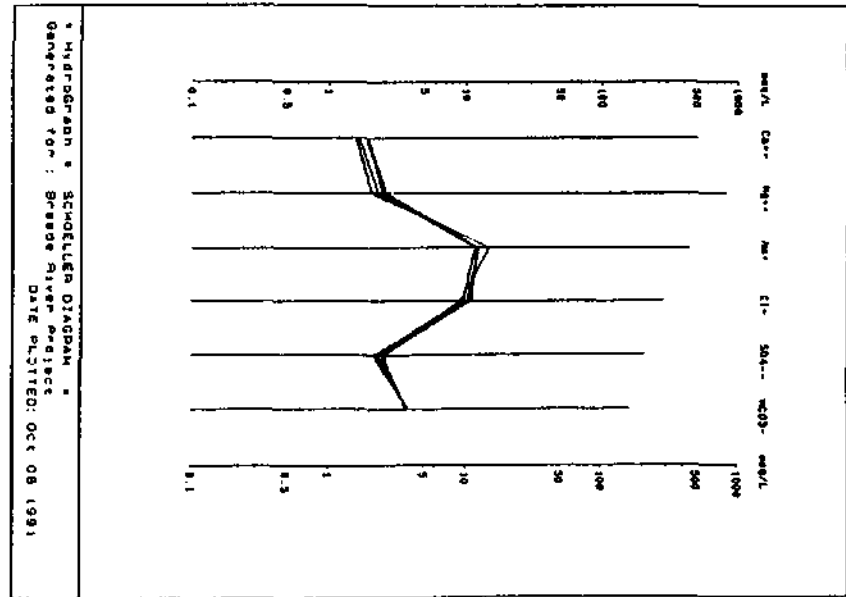
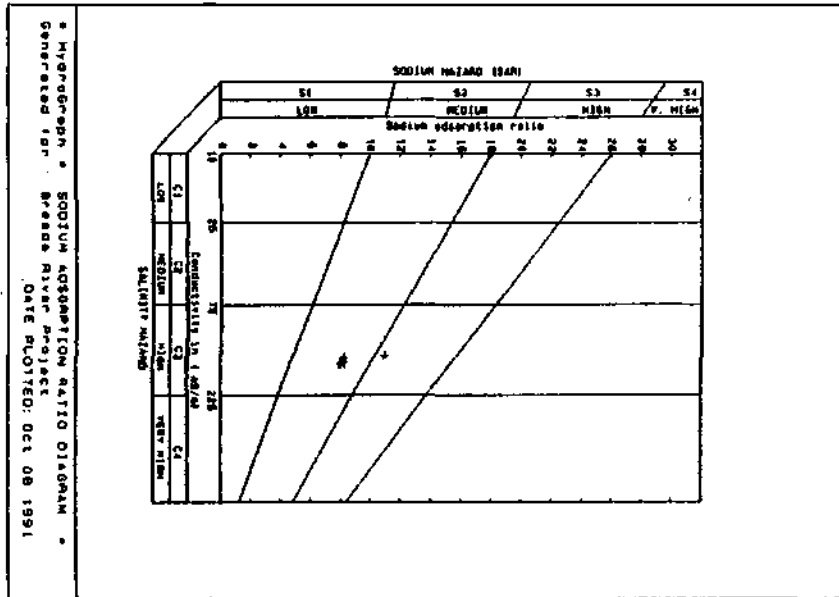
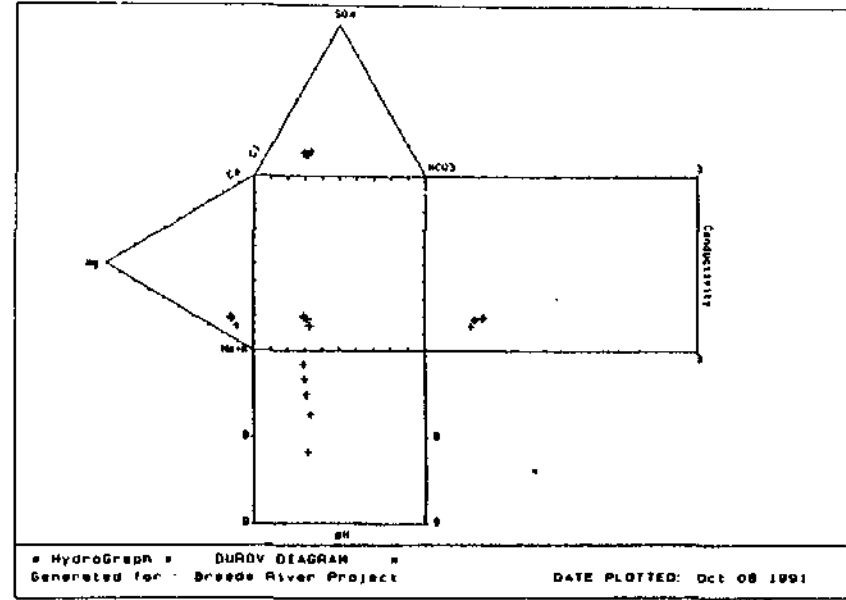
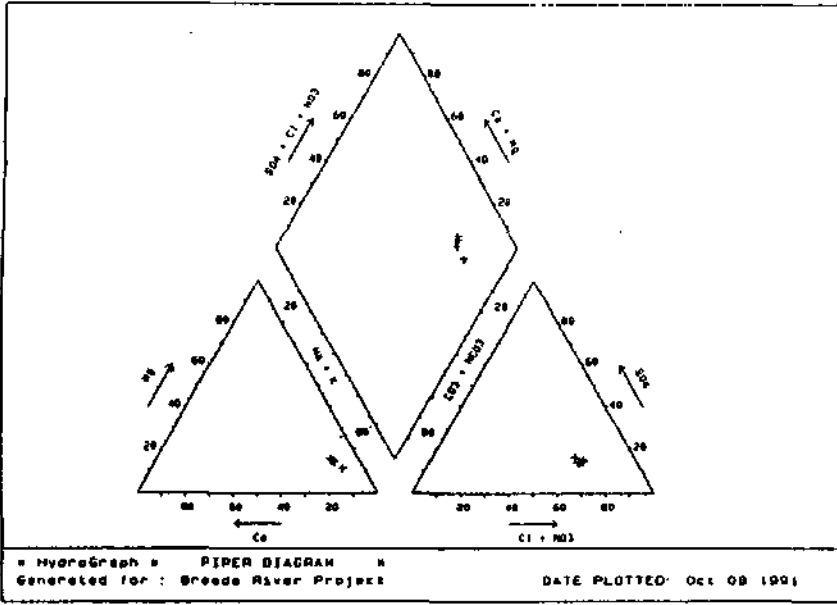

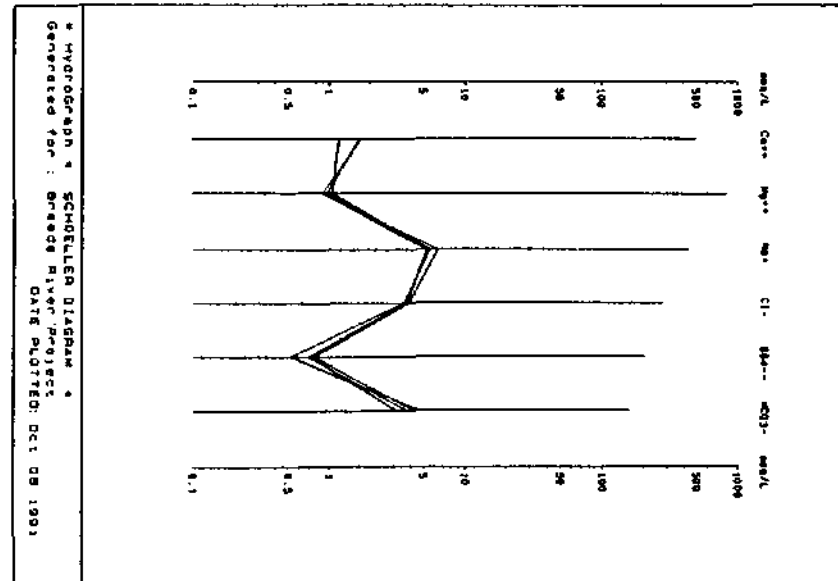
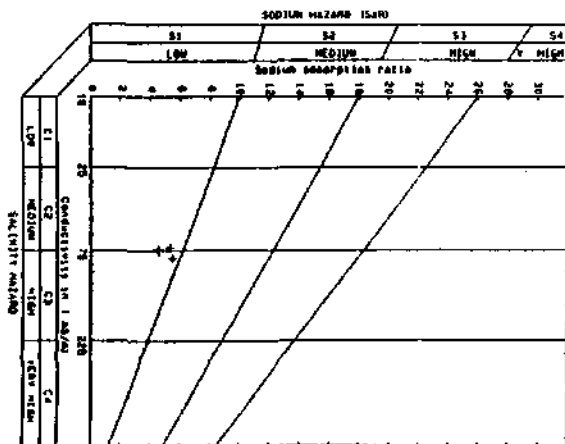
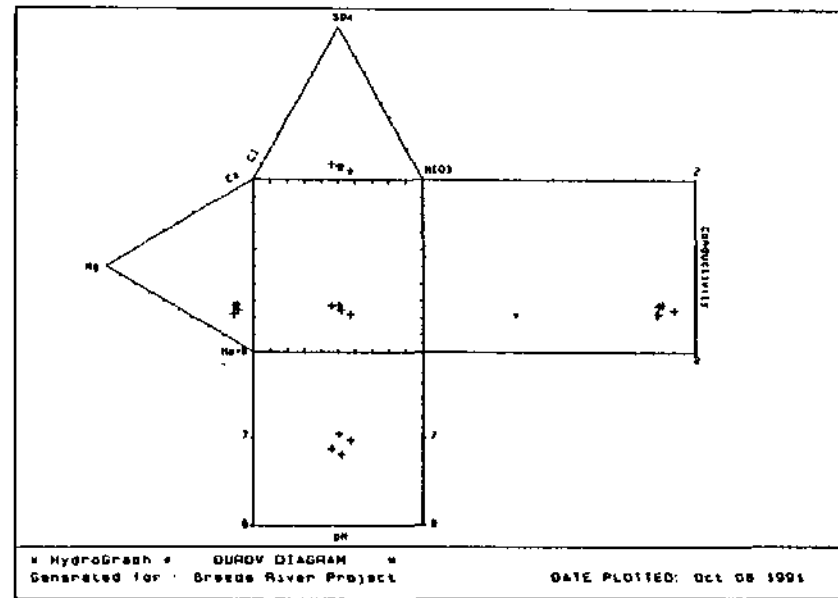
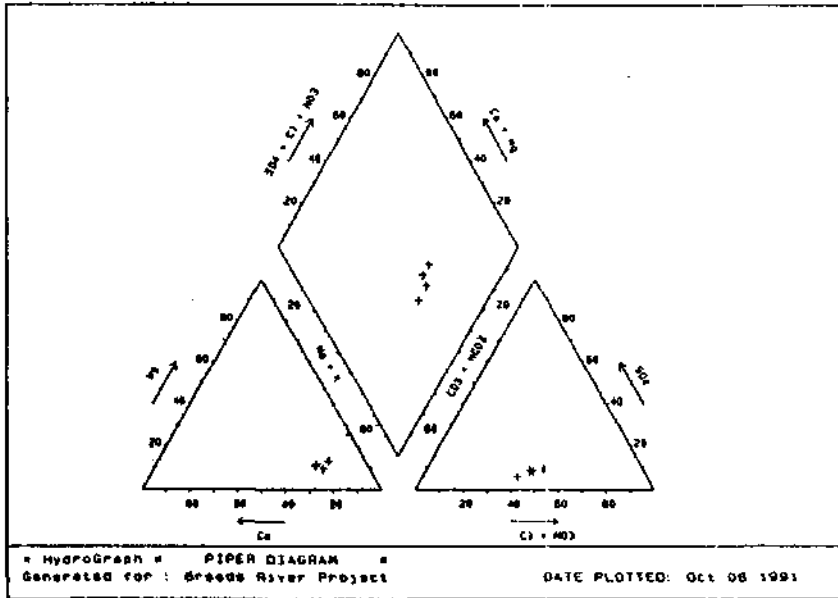

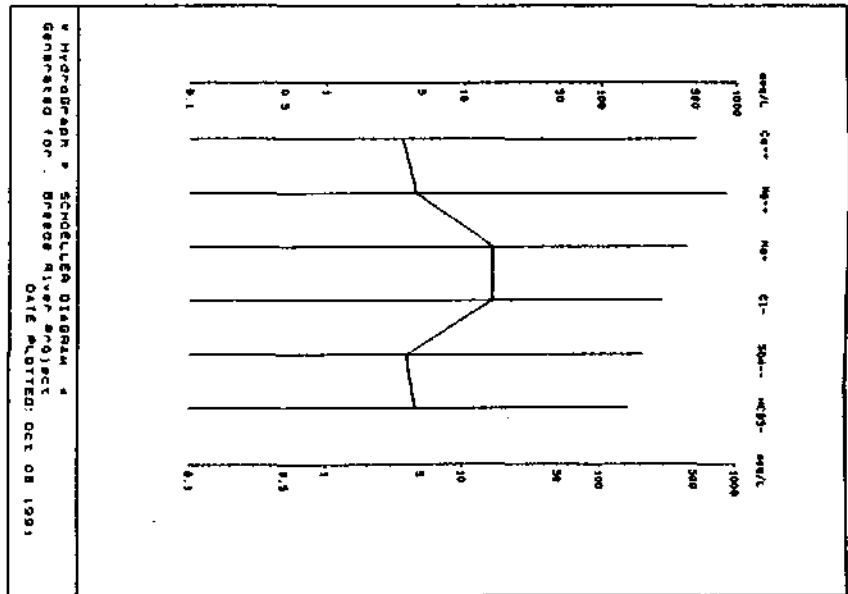
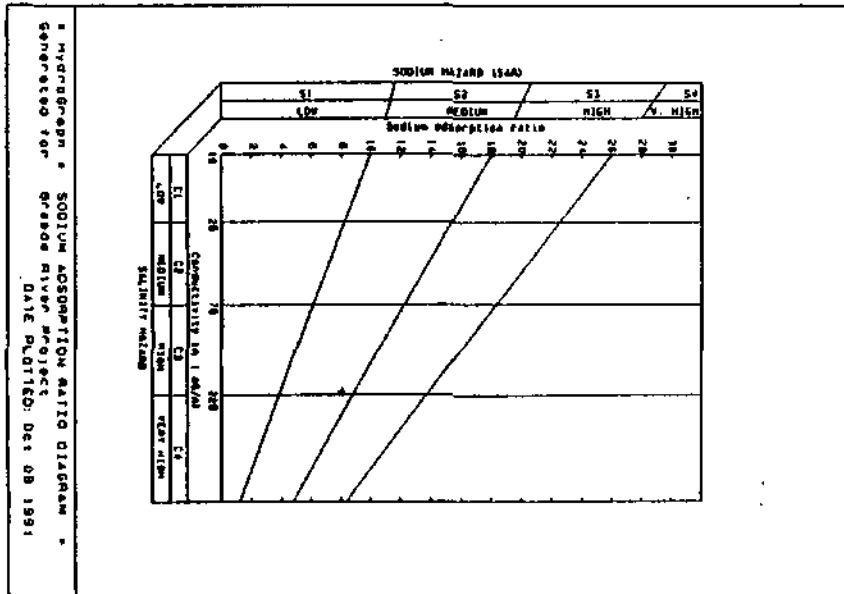
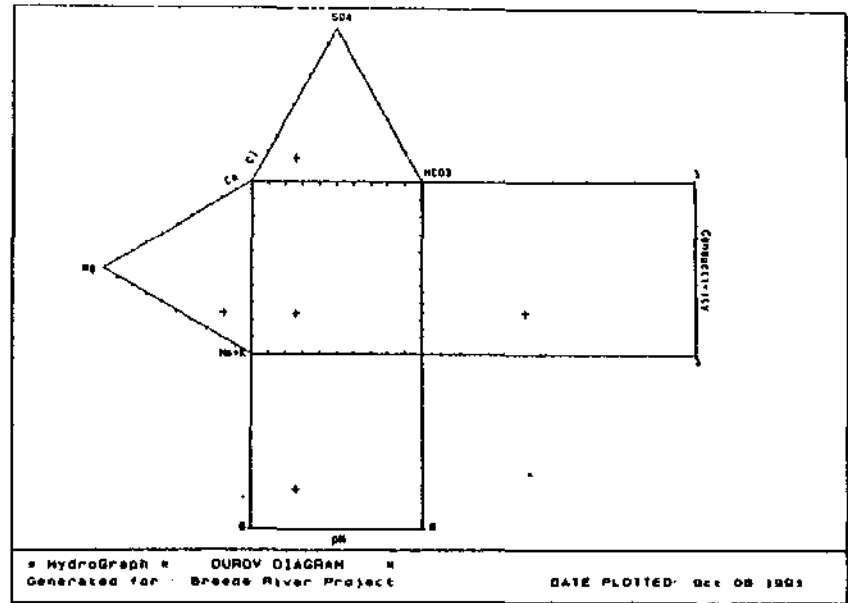
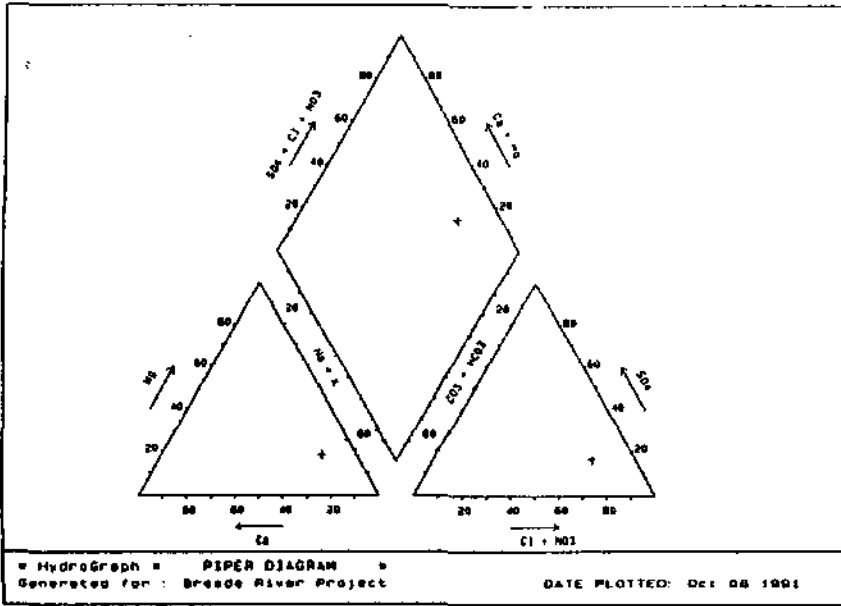

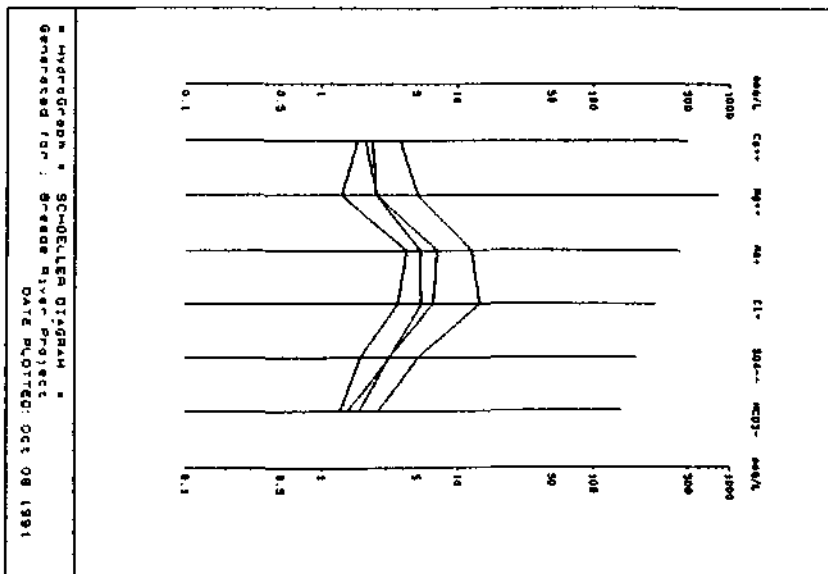
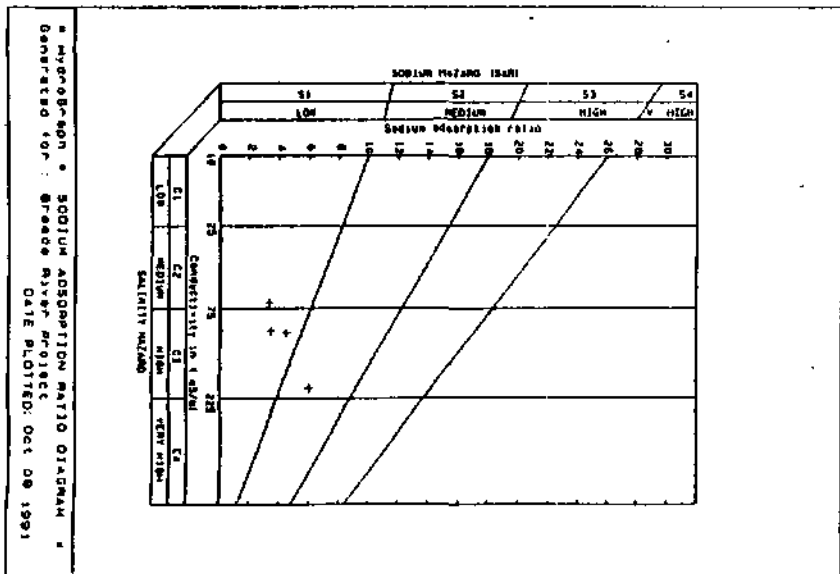
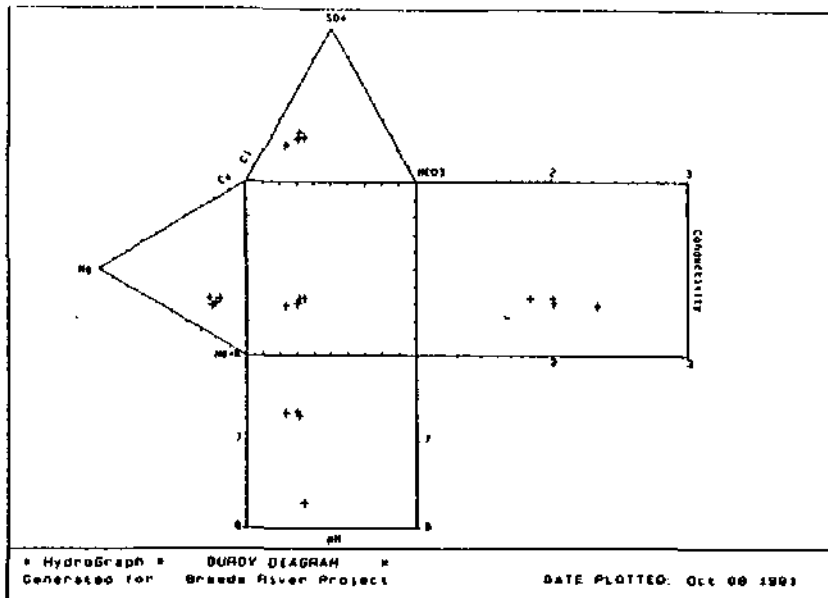
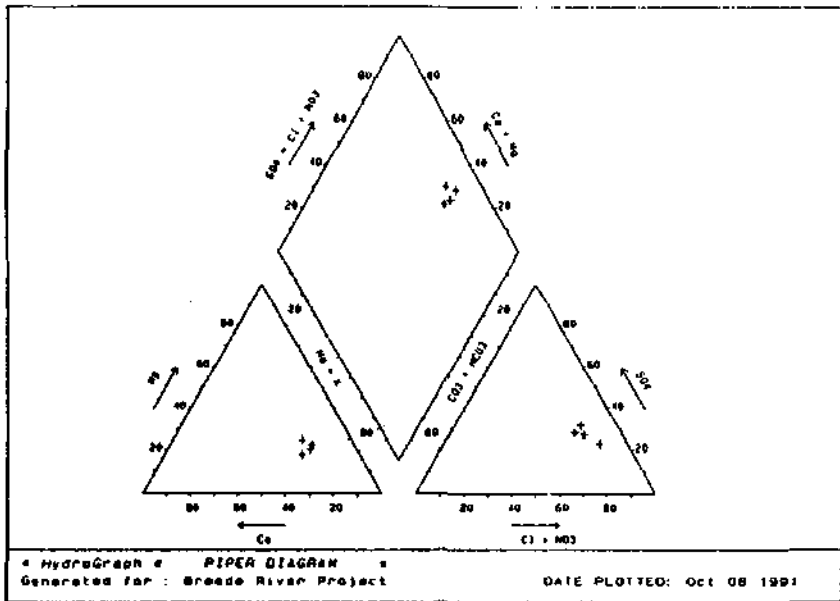

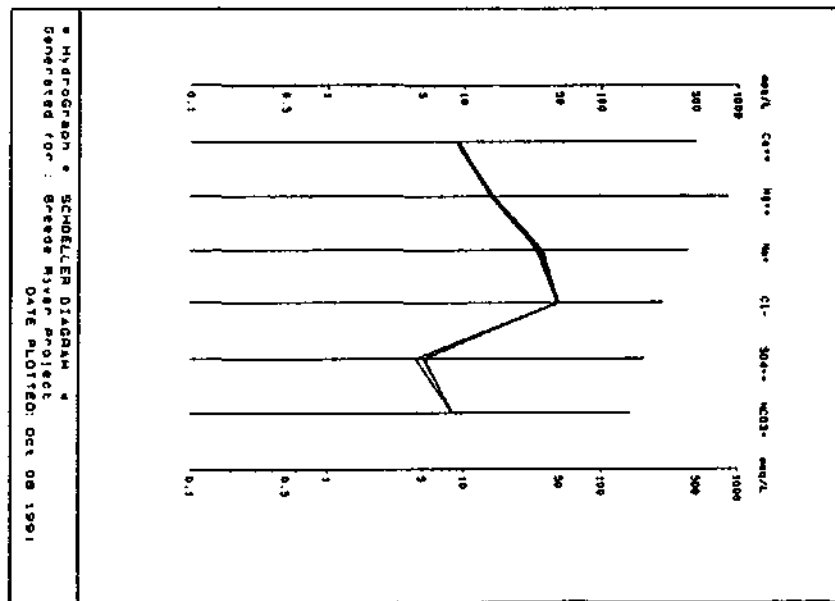
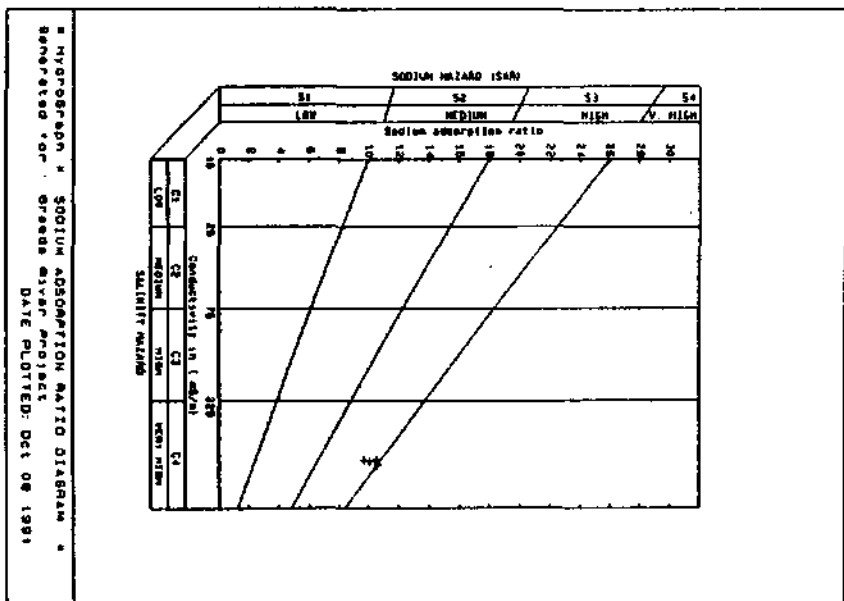
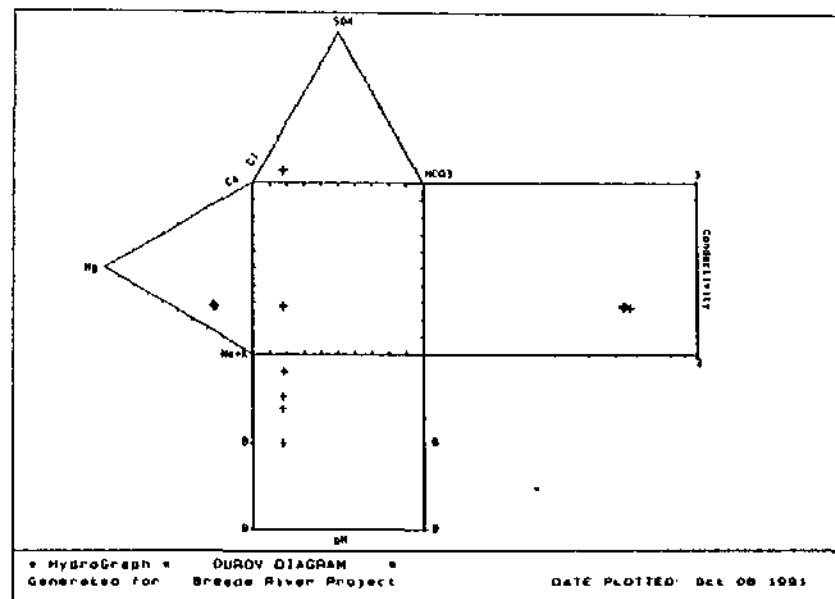
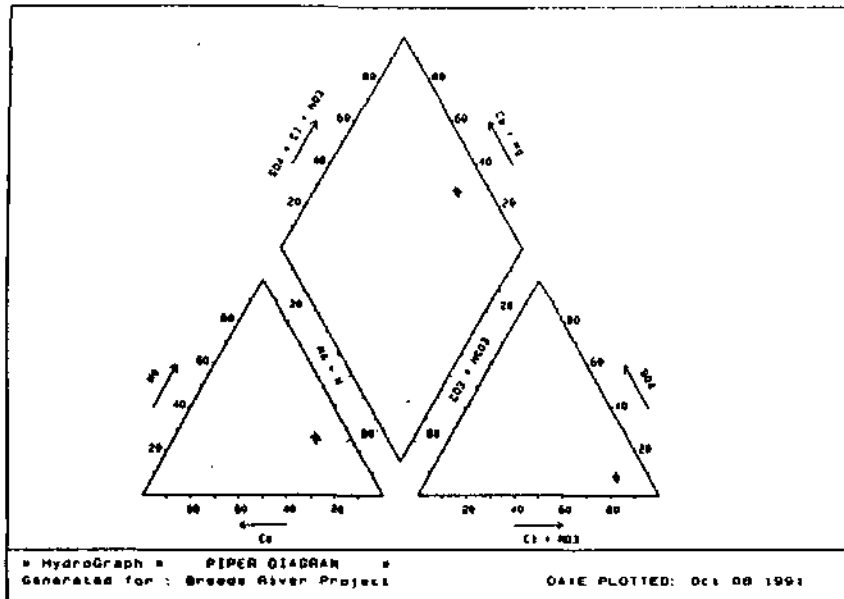

BOKKEVELD 3319DD00001

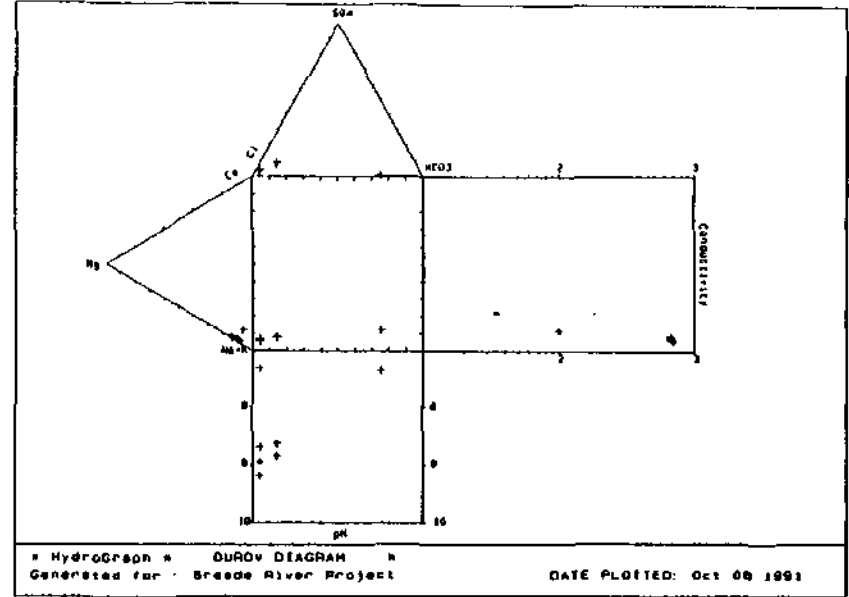
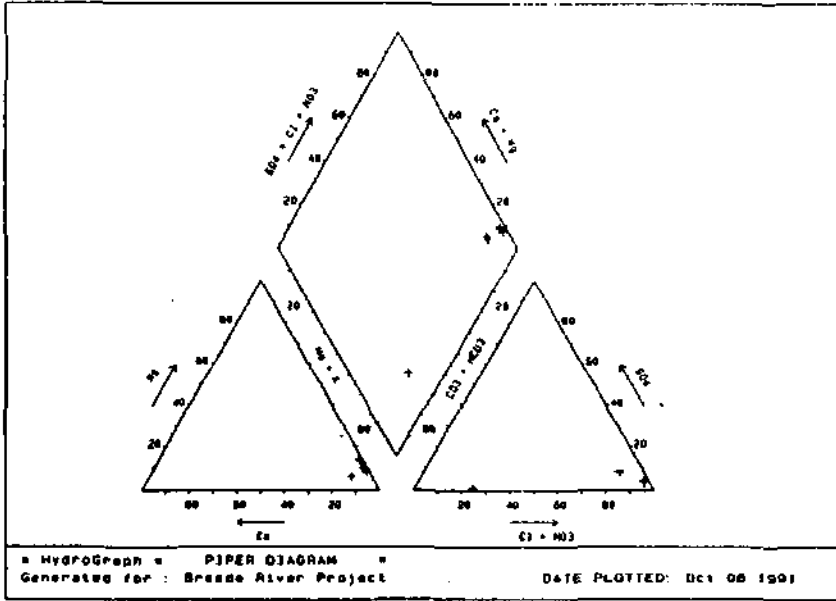

246

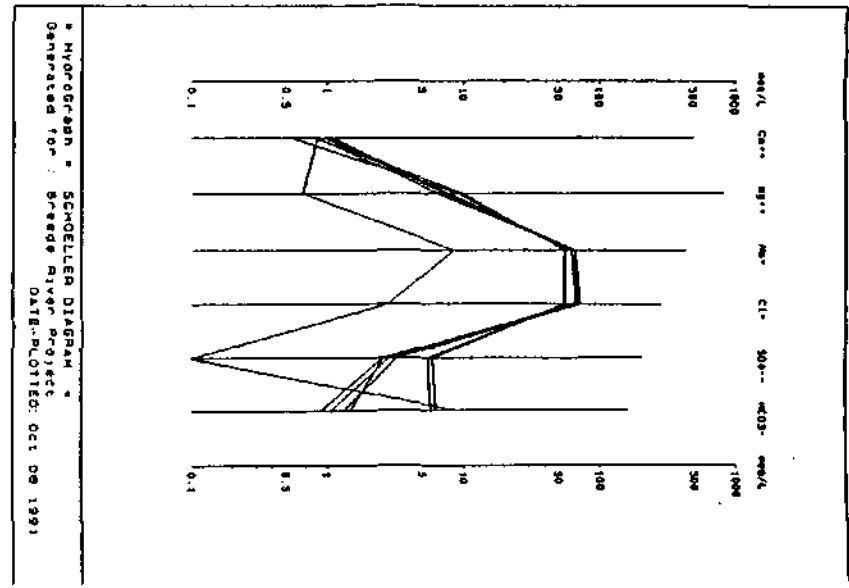
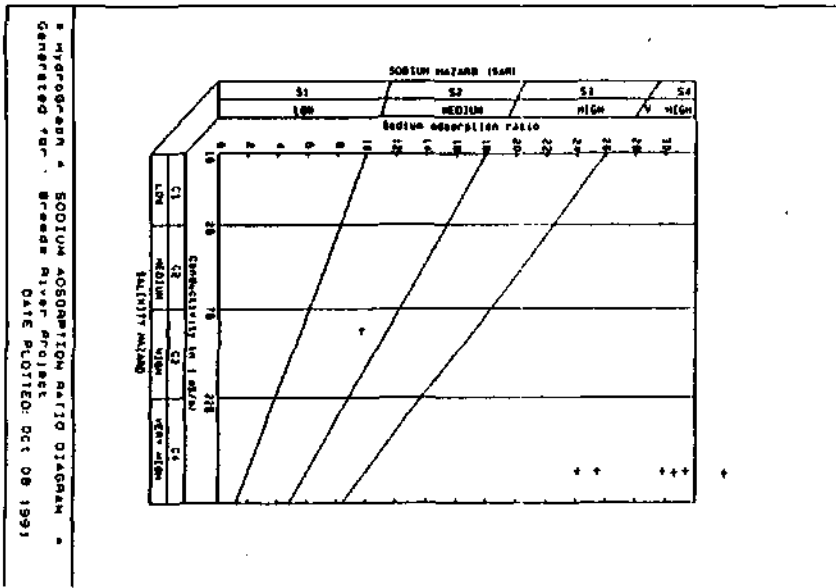

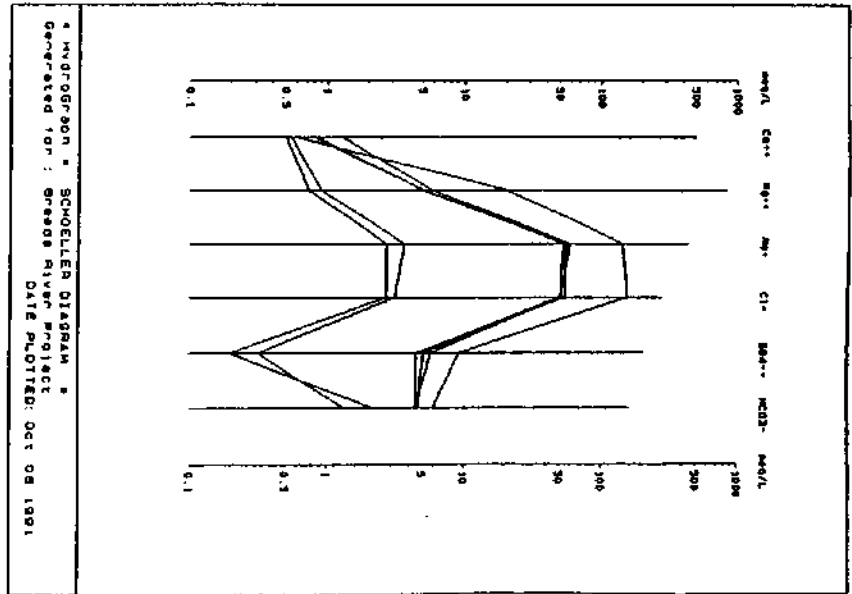
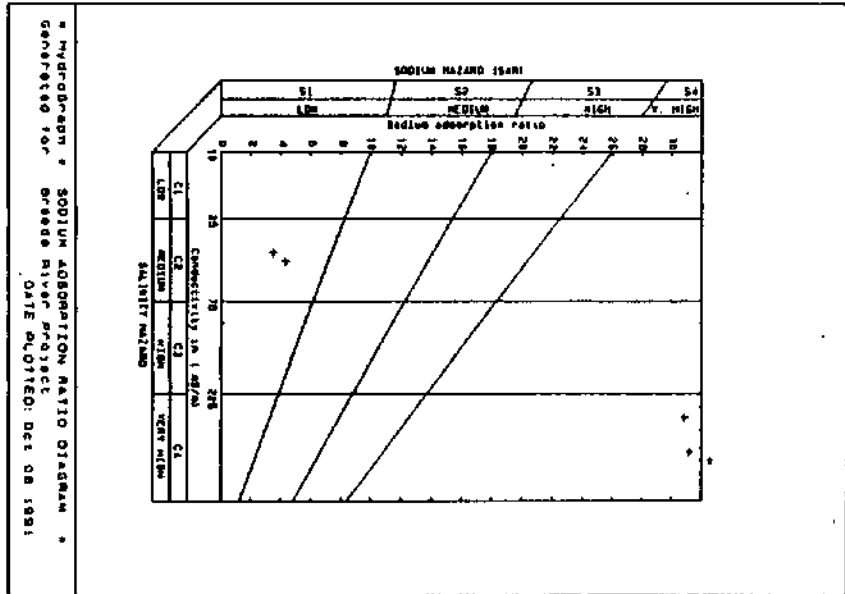
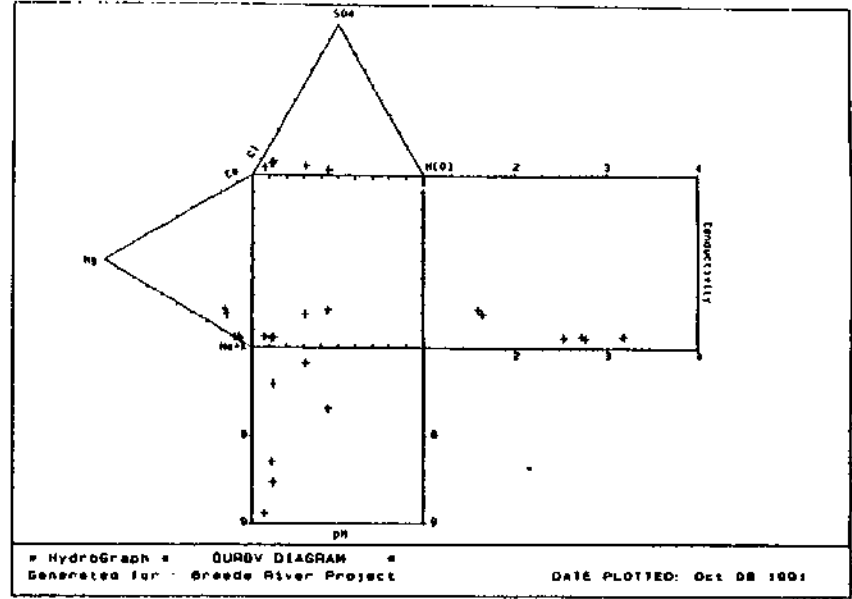
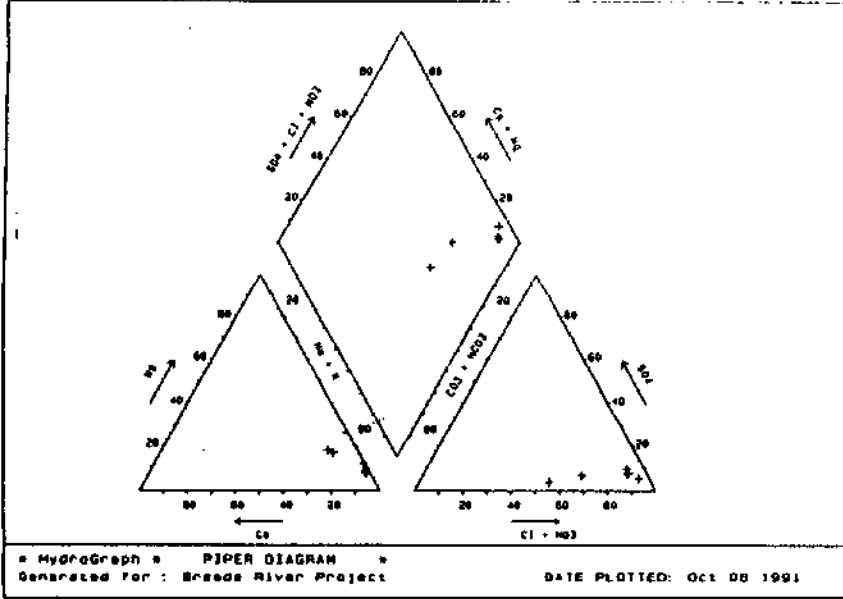

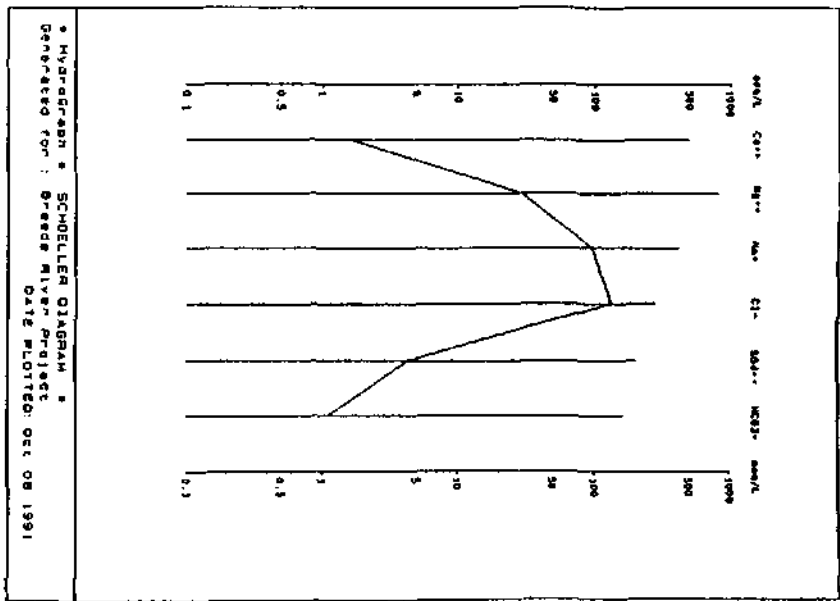
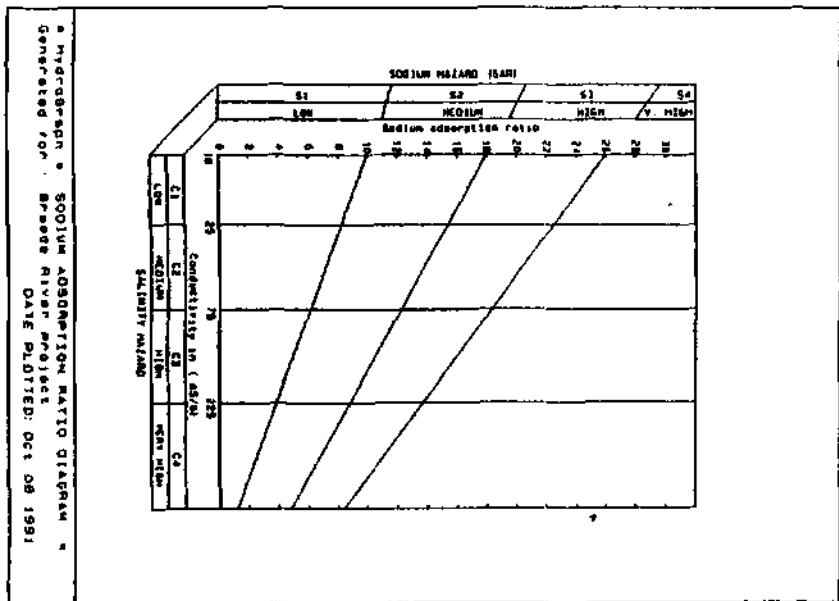
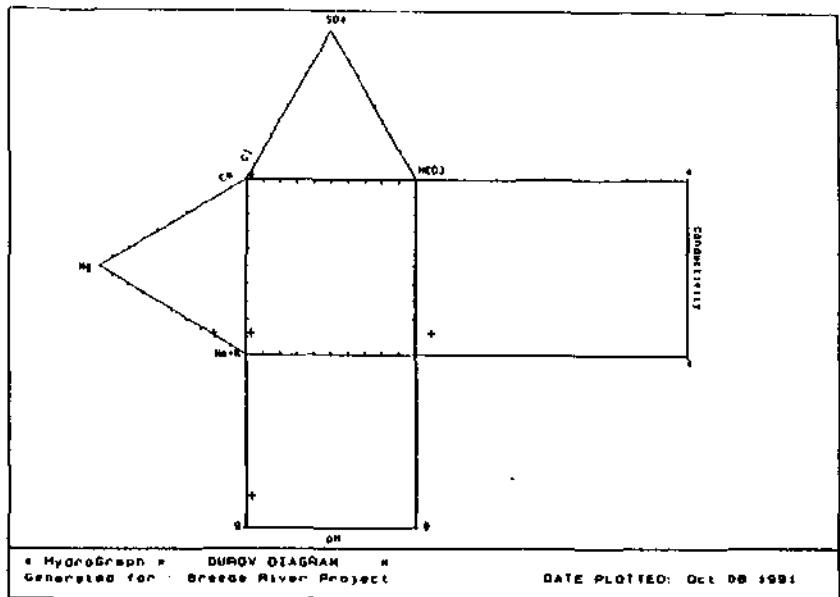
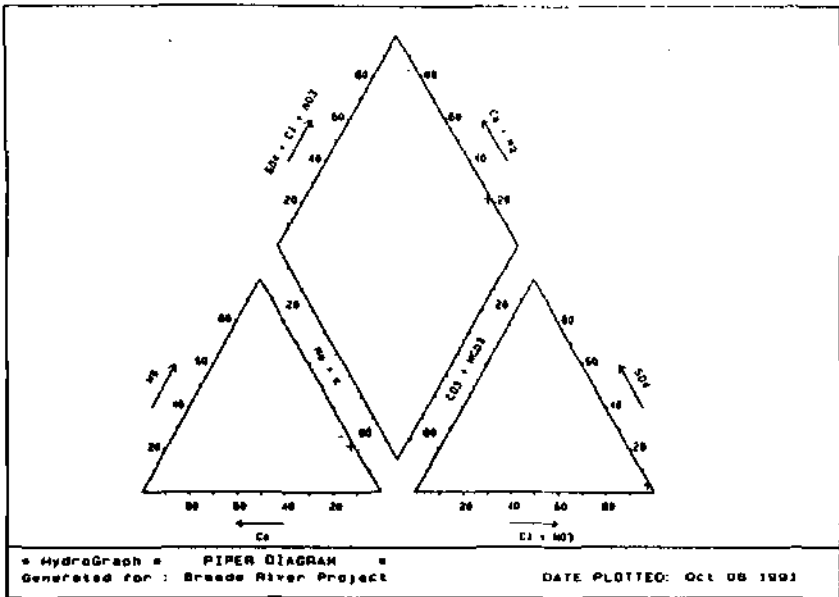

BOKKEVELD 3319DDOQQ08

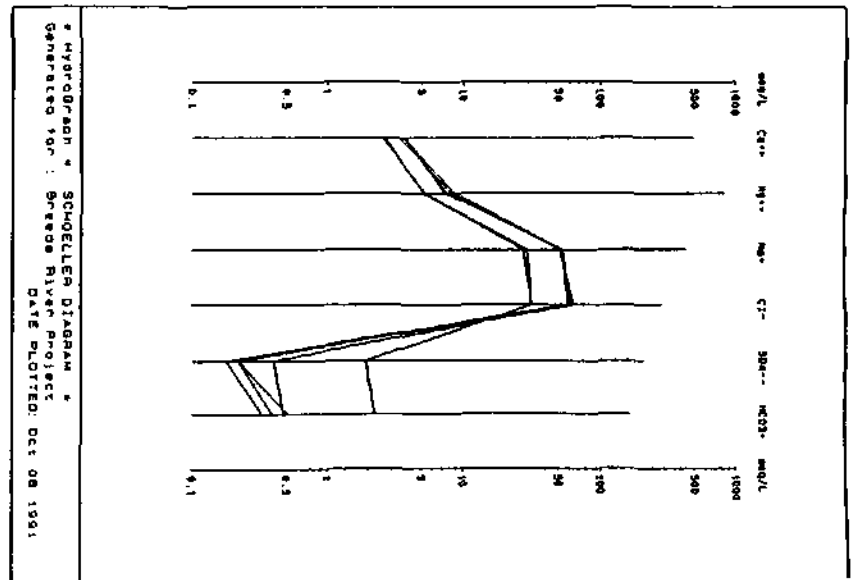
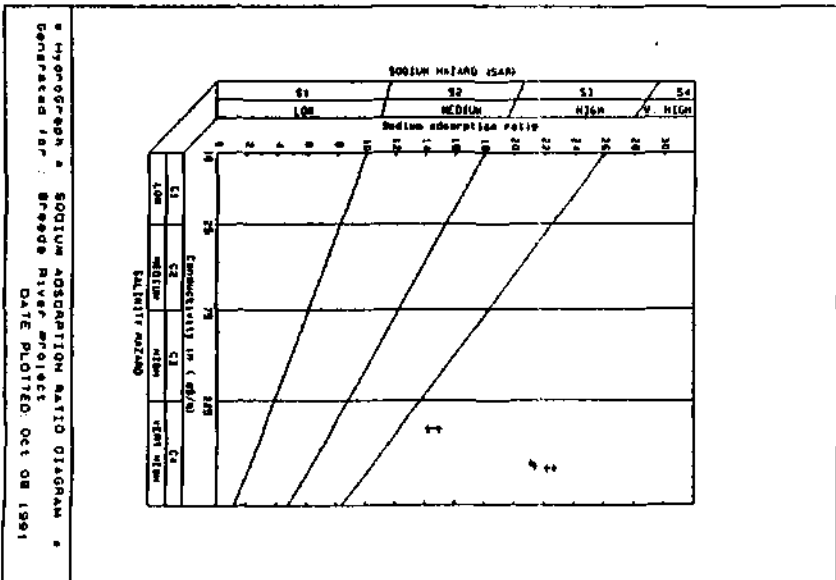
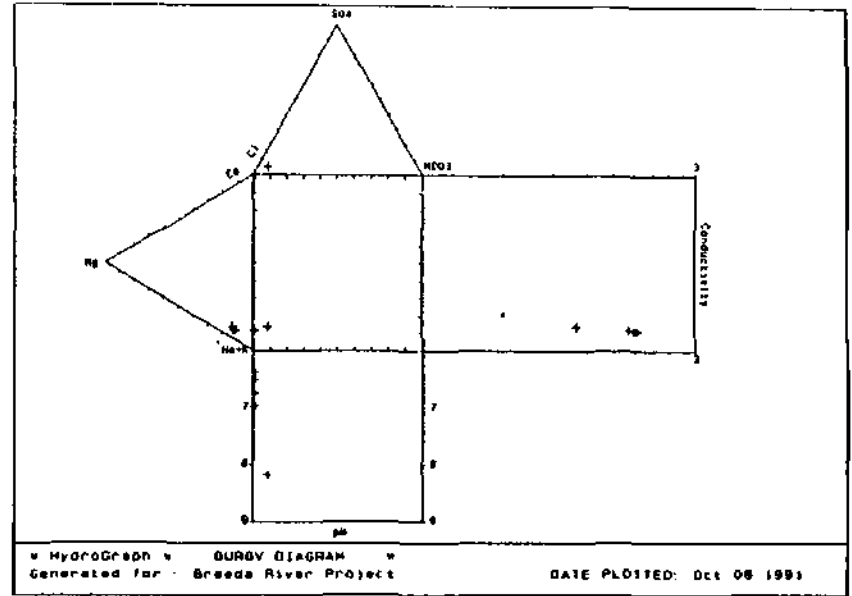
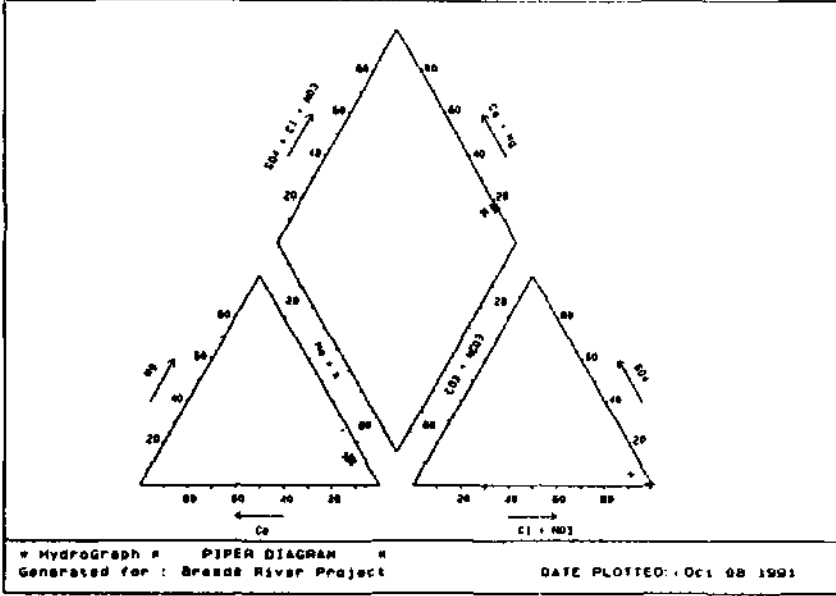

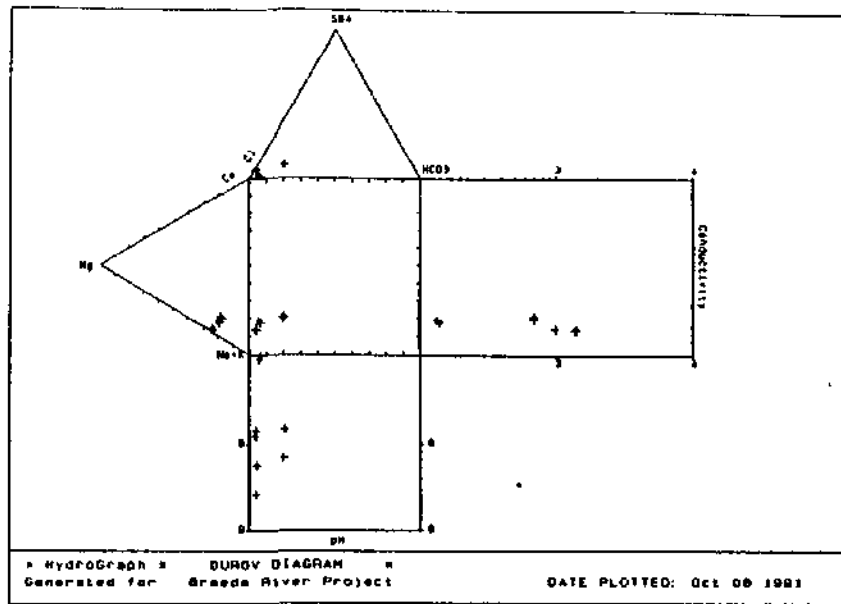
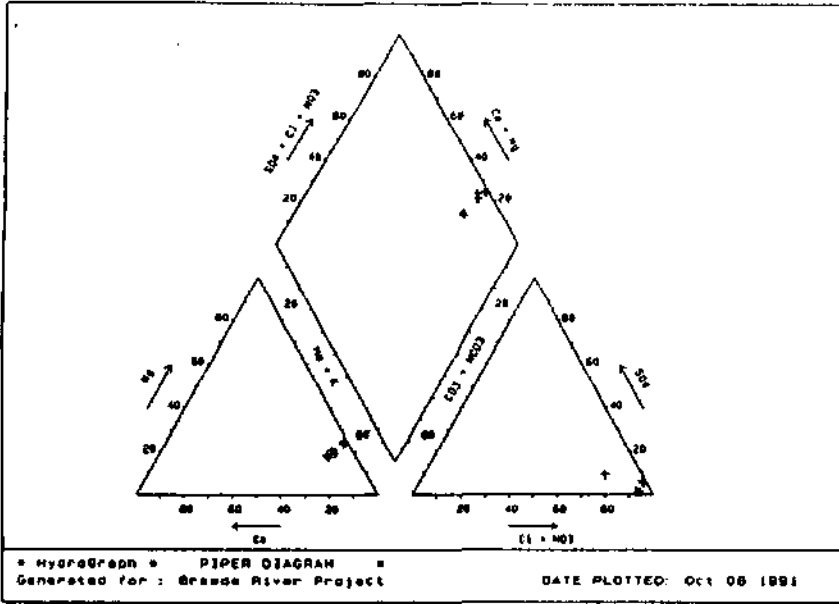

250

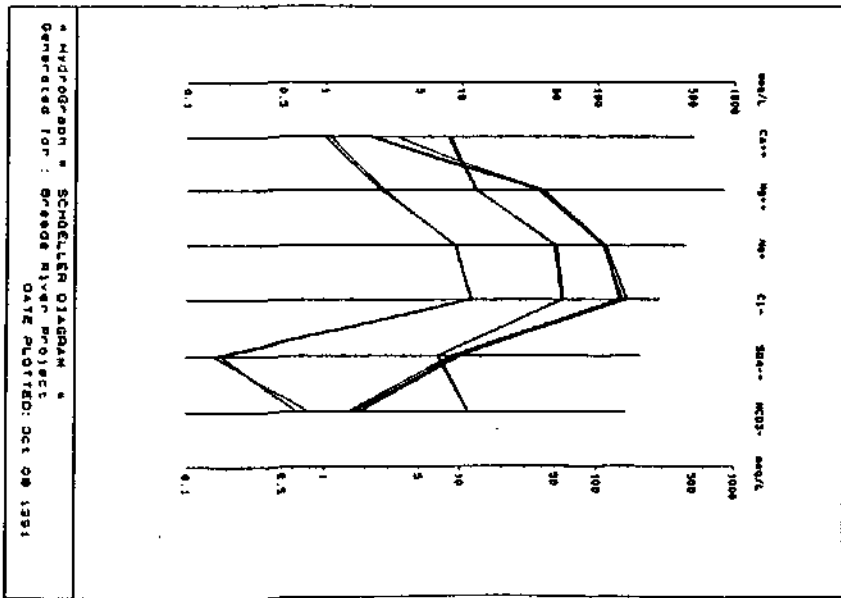
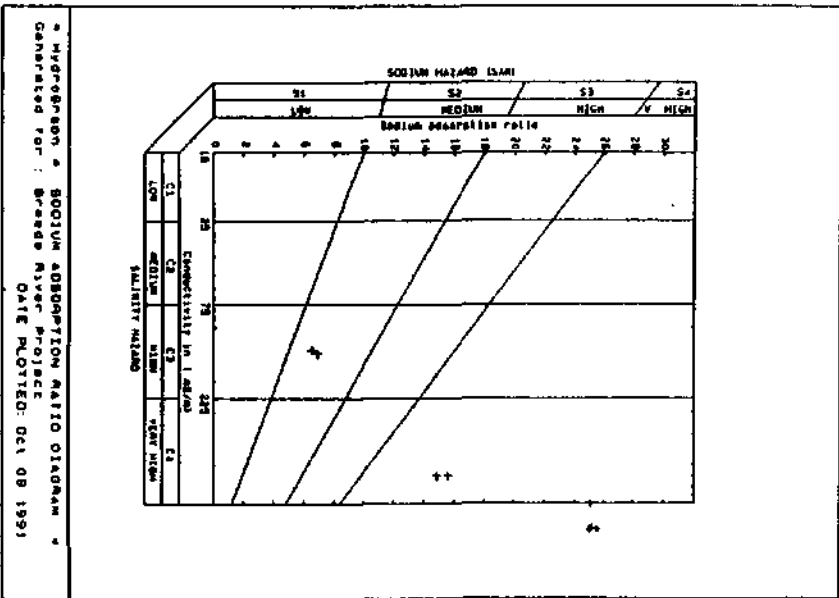

BOKKEVELD 3319DD00016

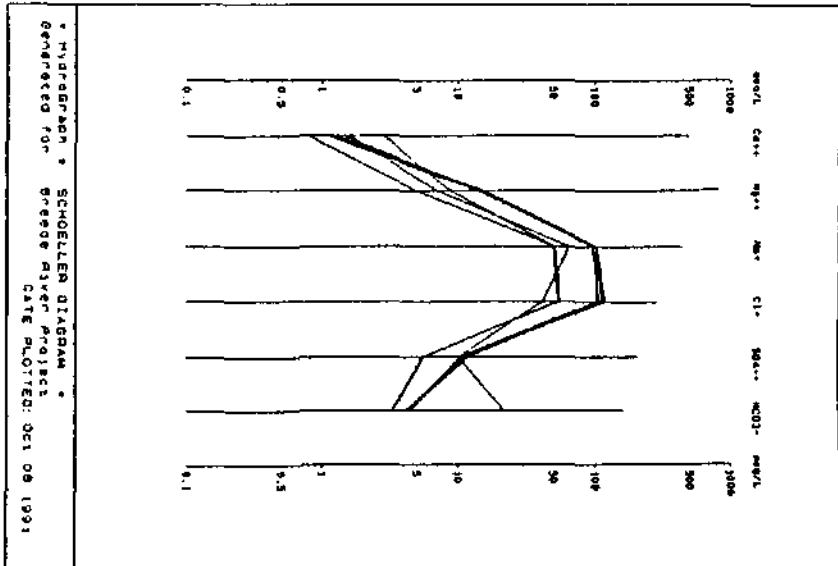
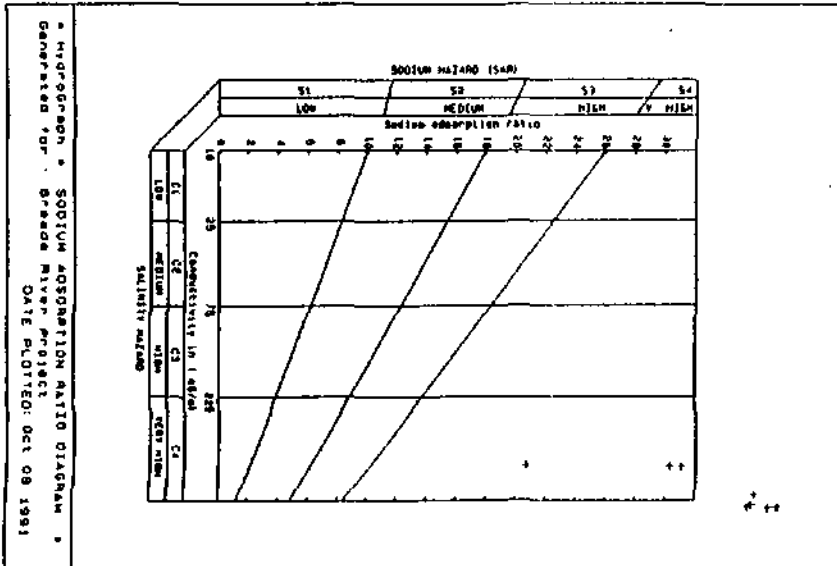
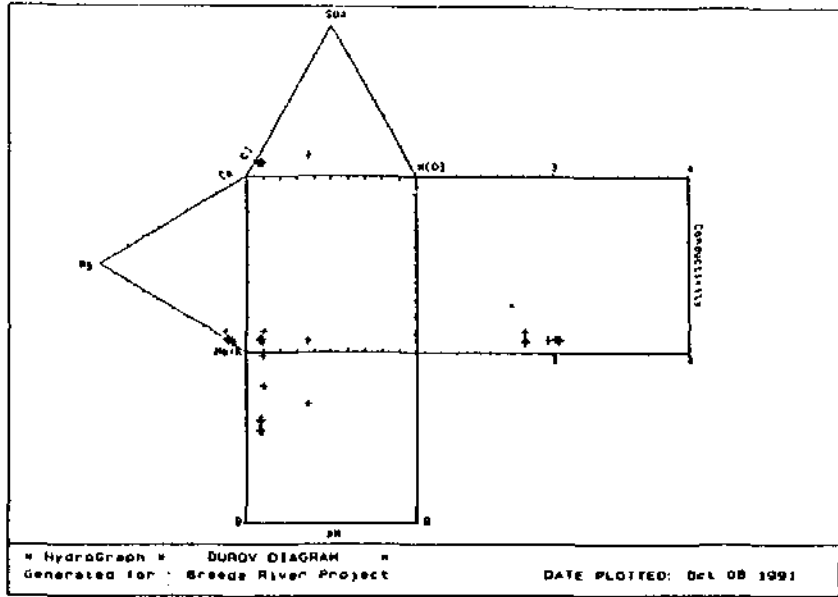
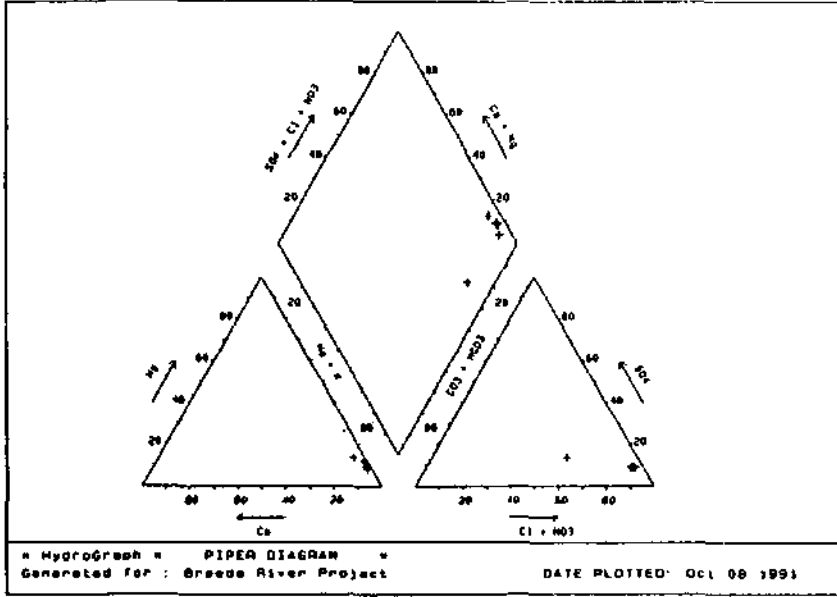

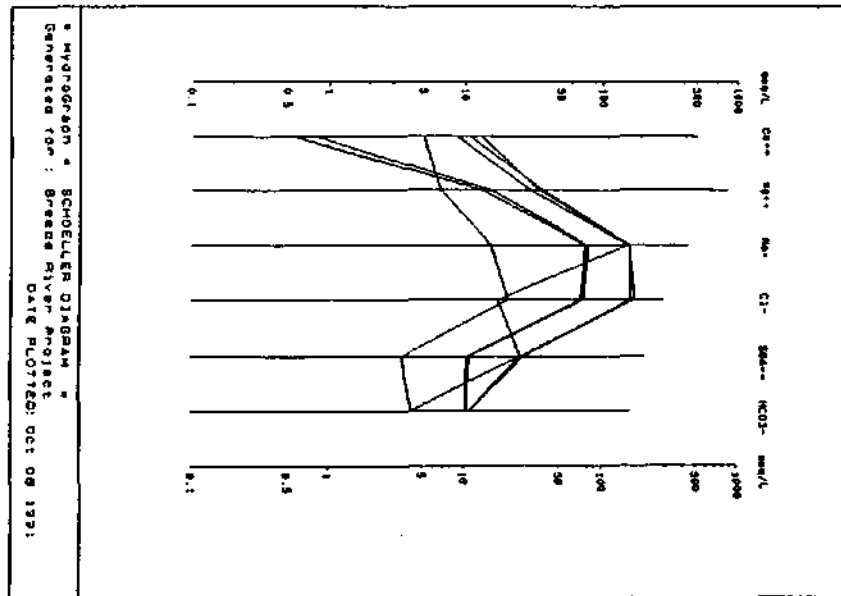
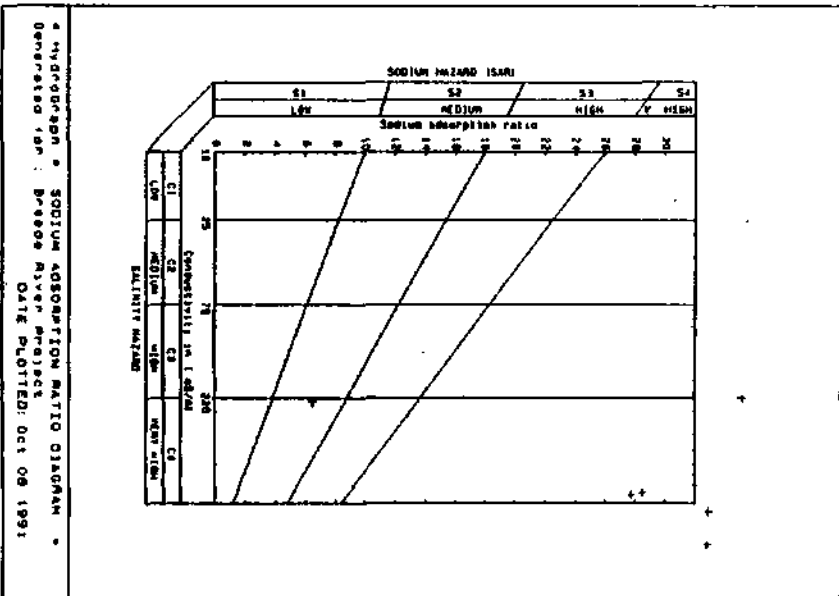
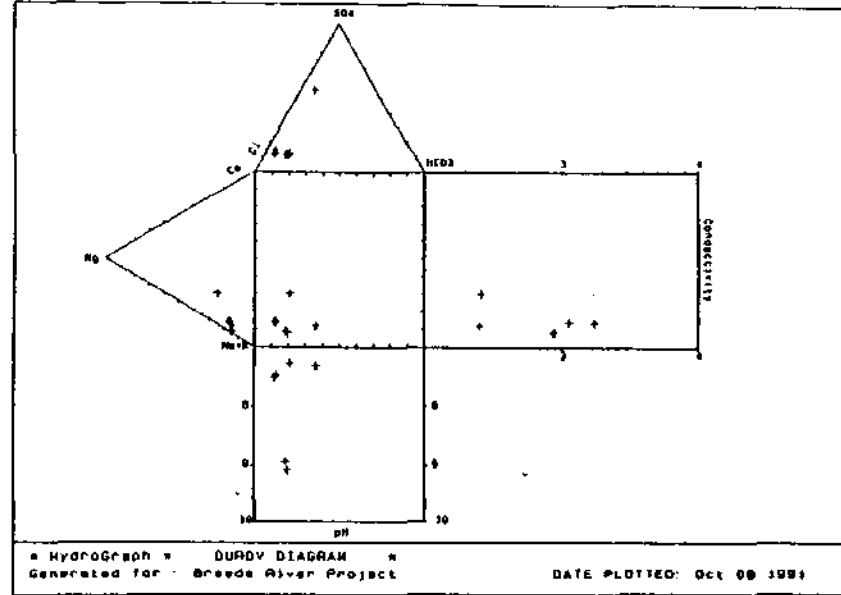
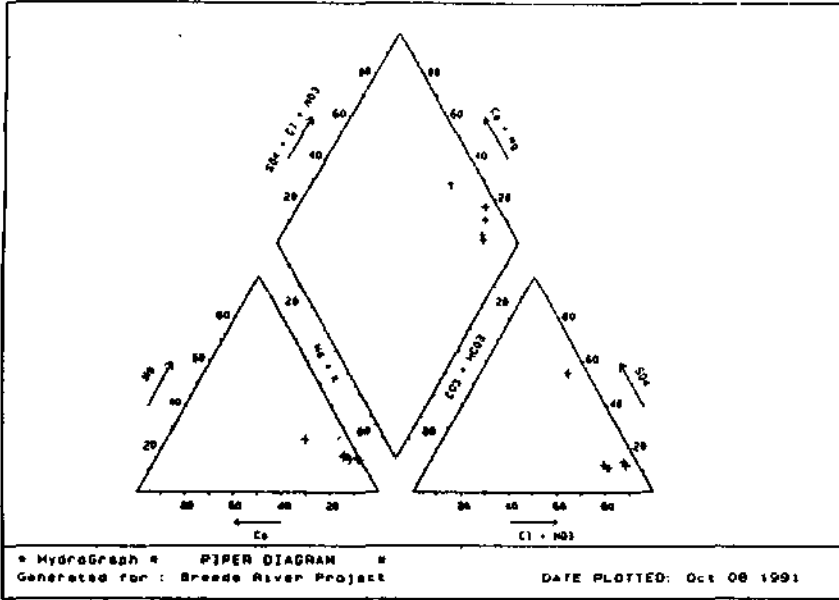

BOKKEVELD 3319DD00021

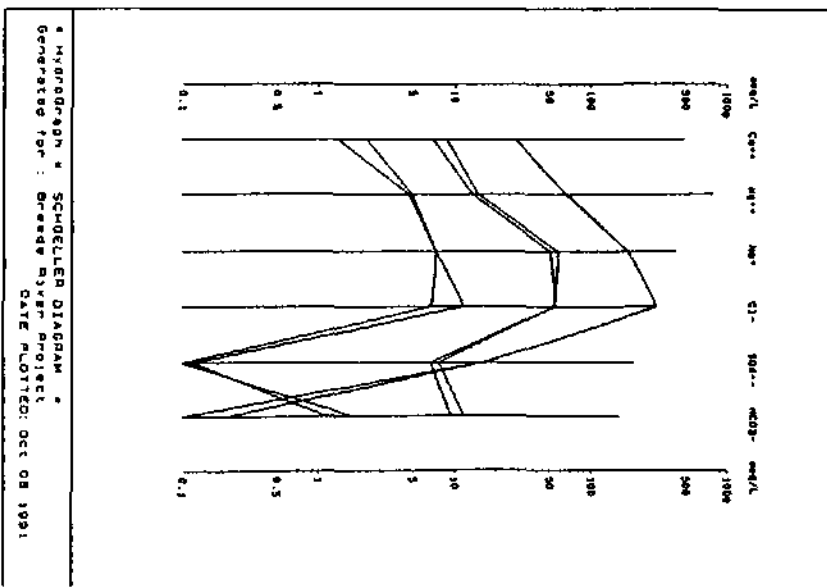
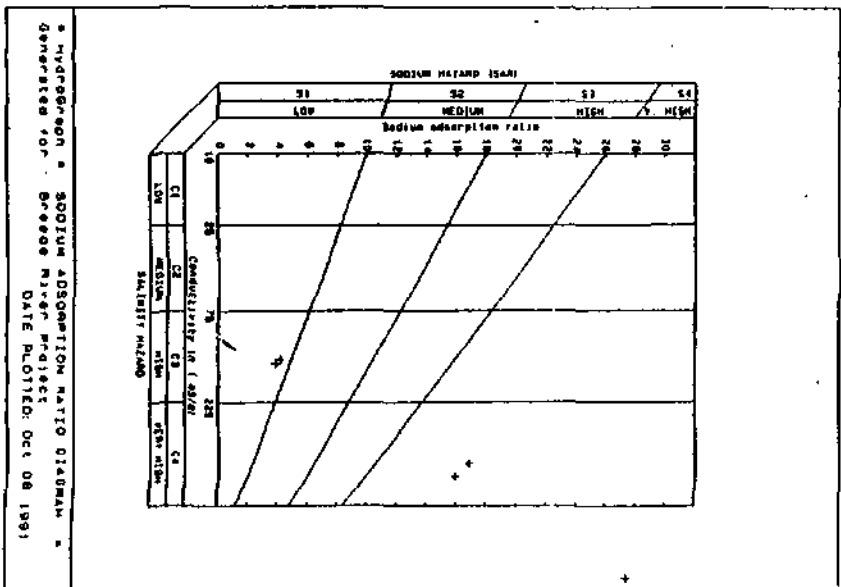
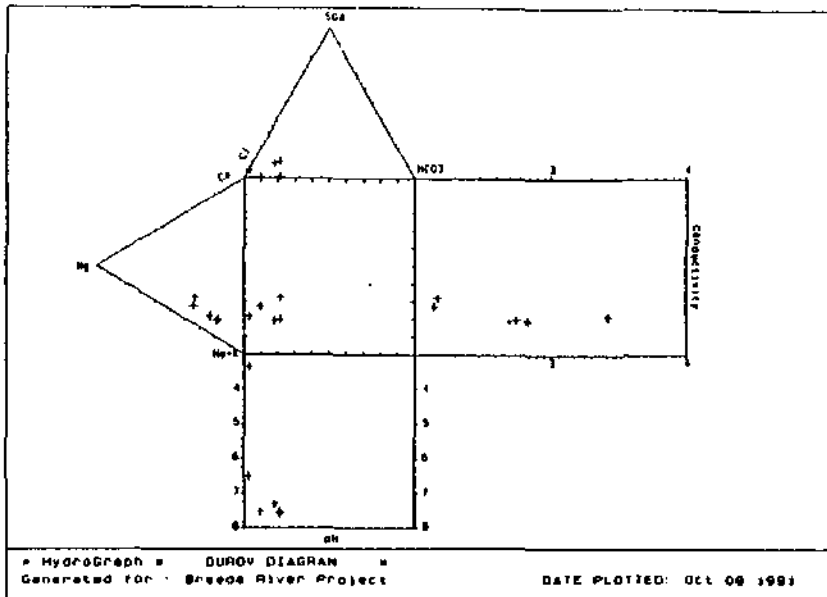
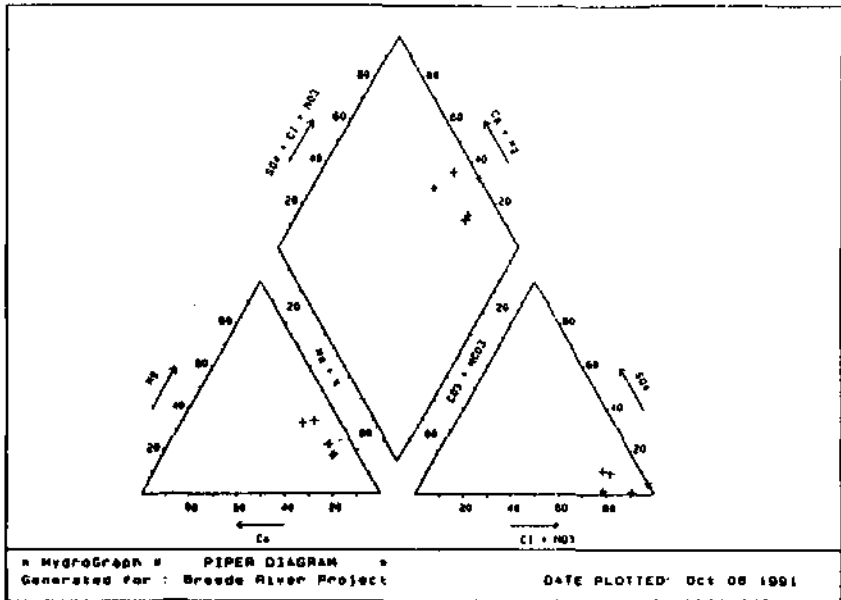

253

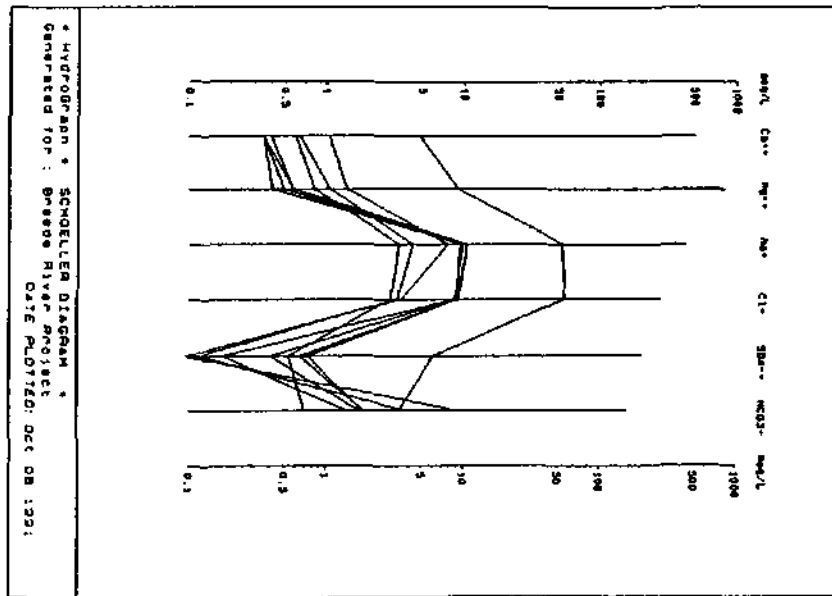
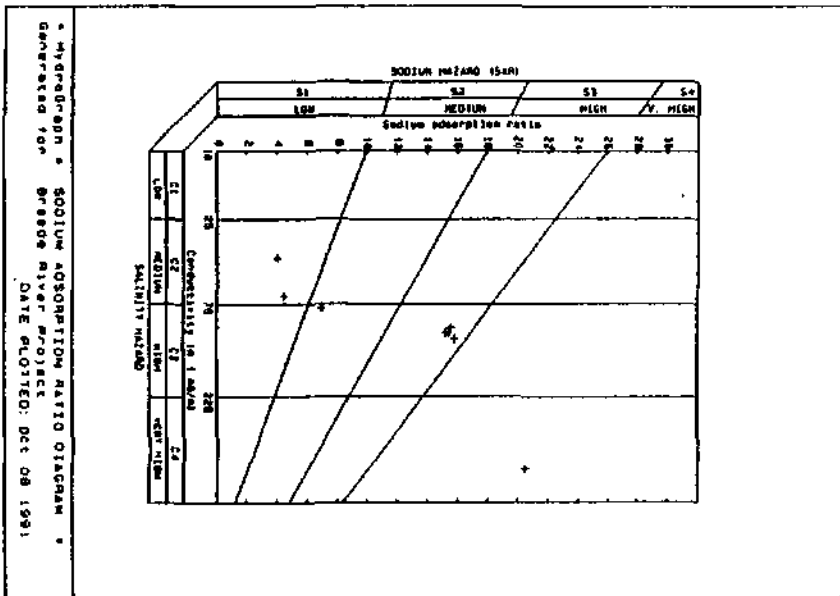
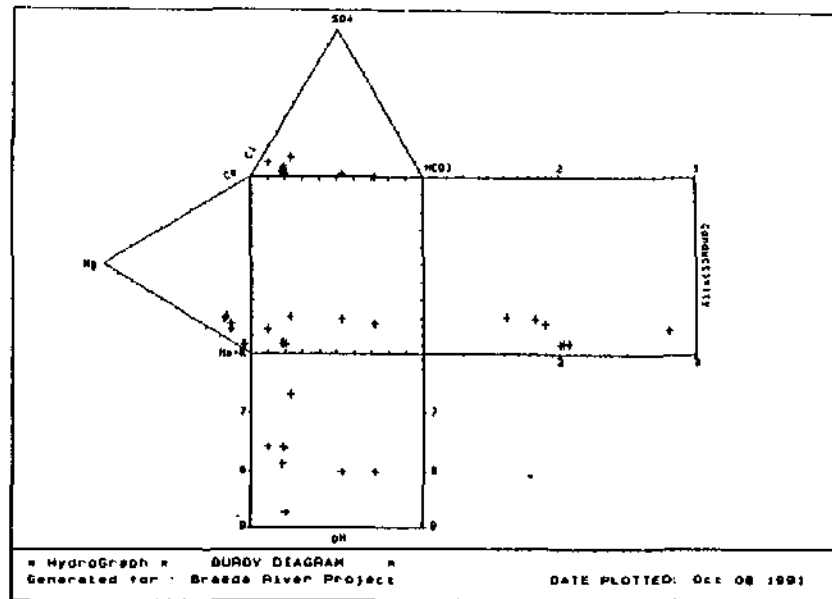
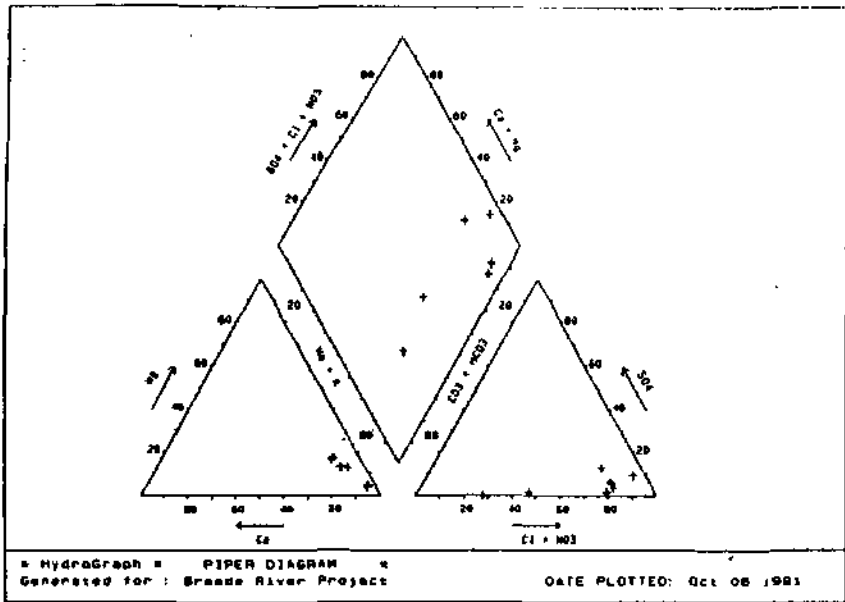

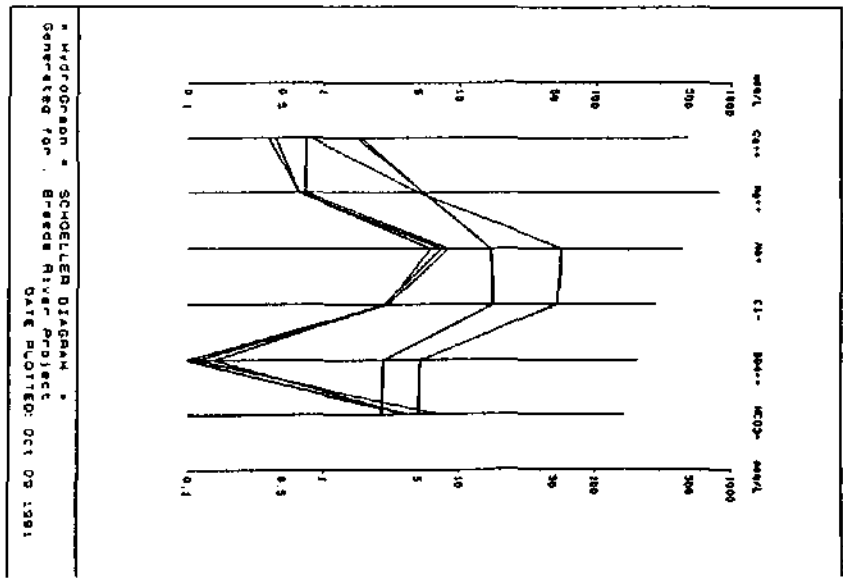
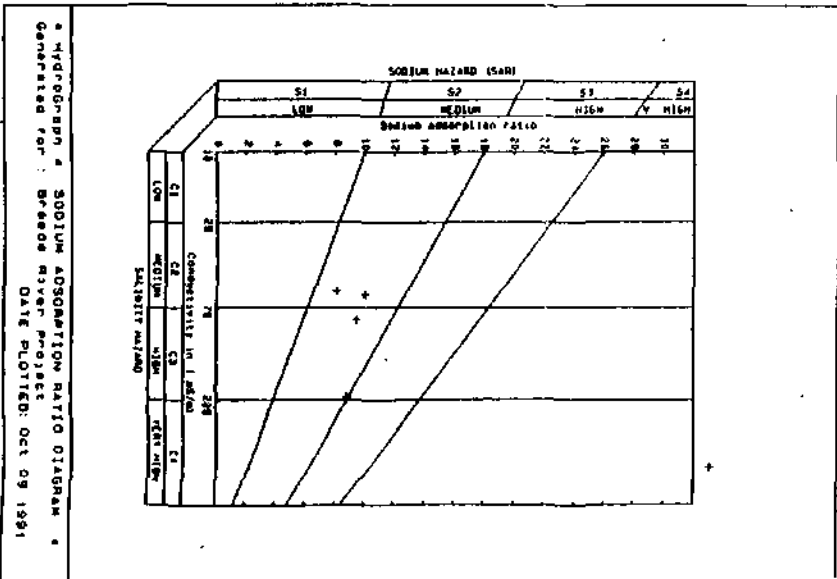
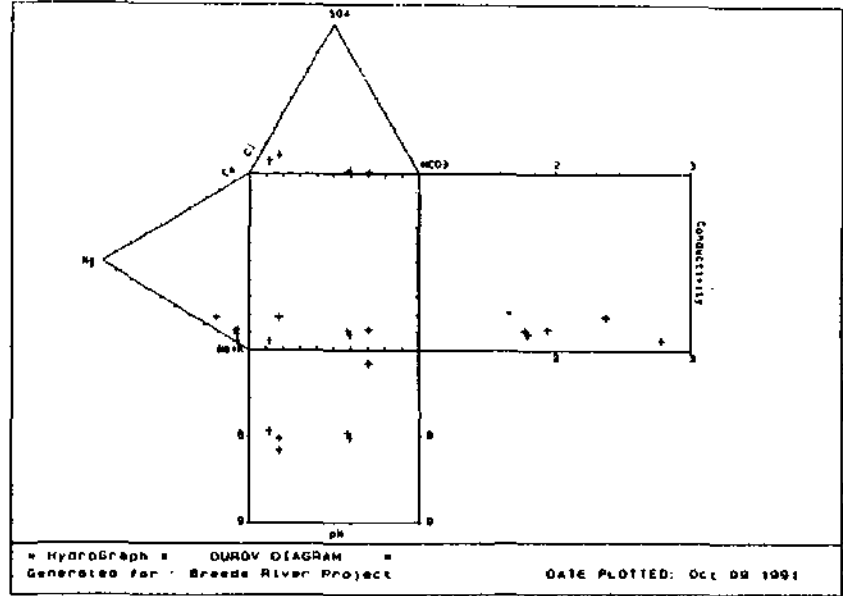
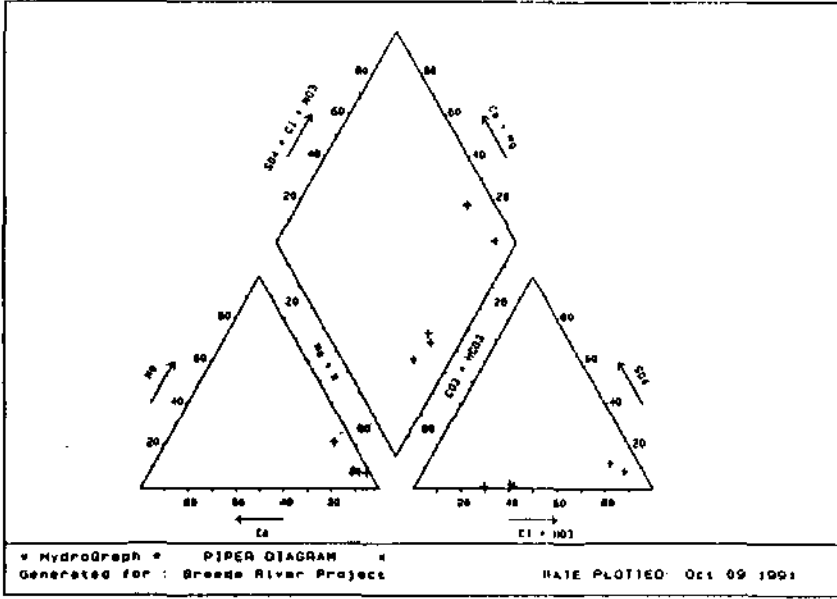

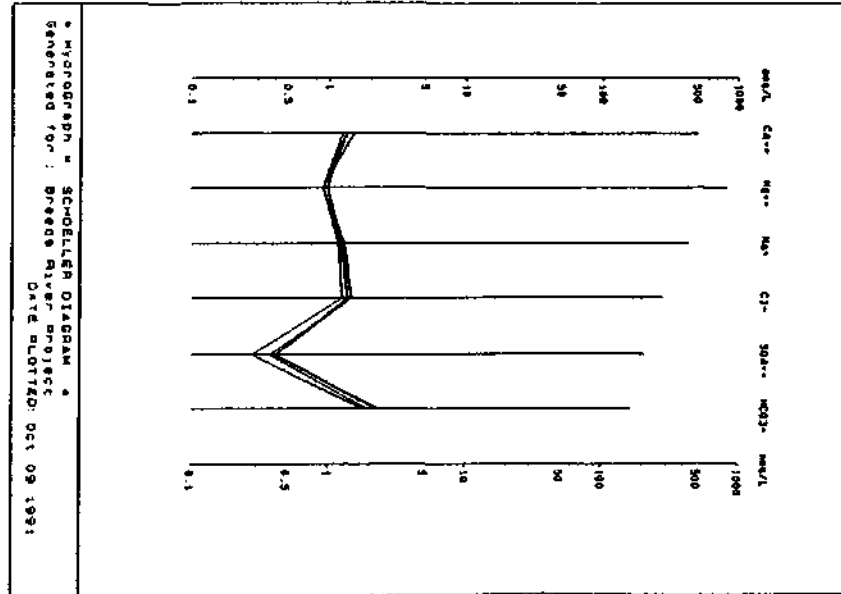
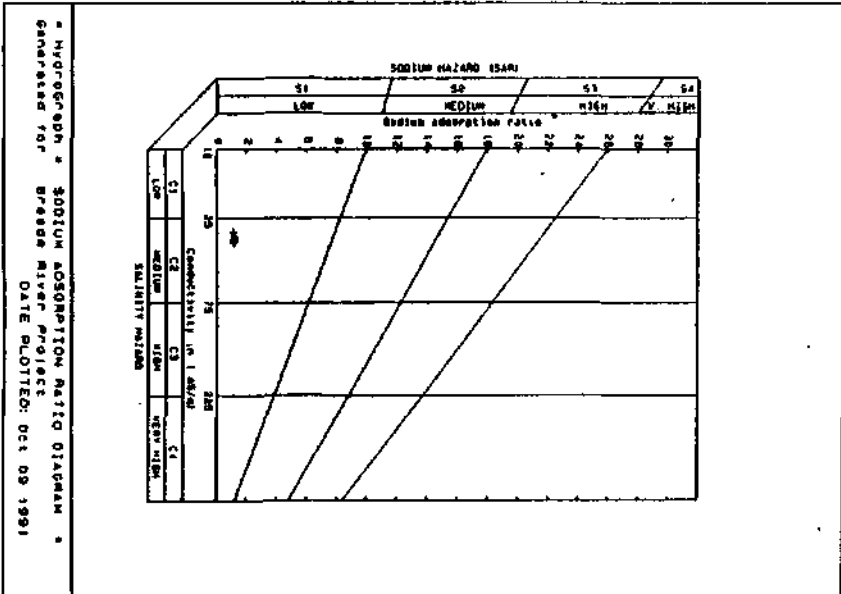
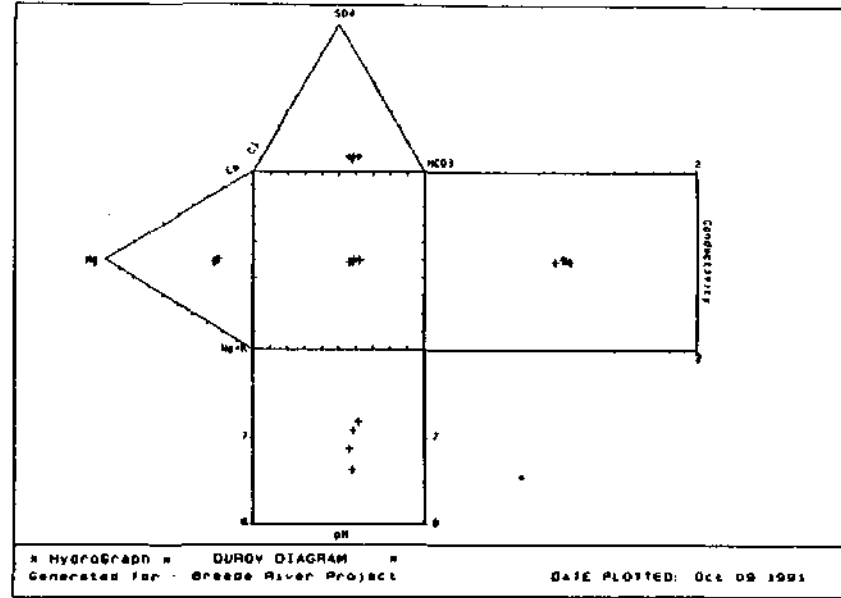
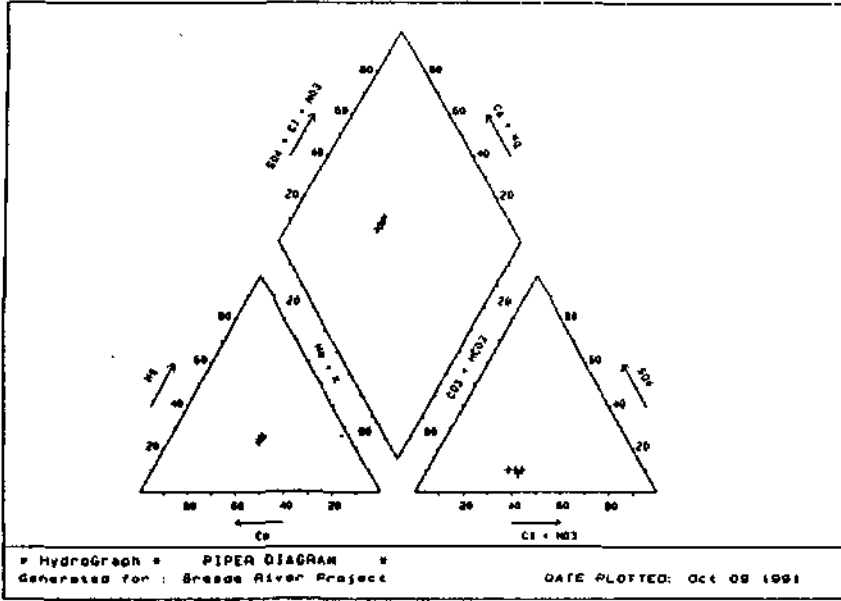

BOKKEVELD 3319DD00042

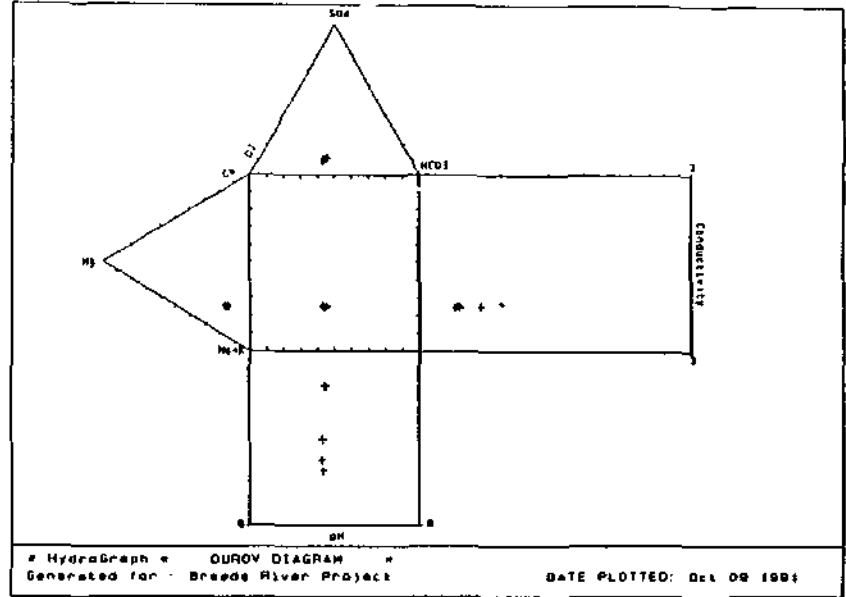
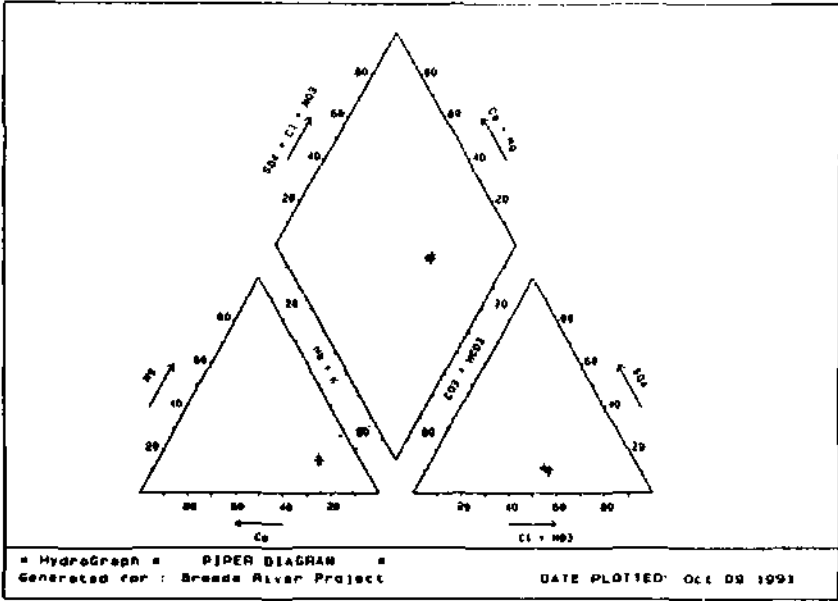

257

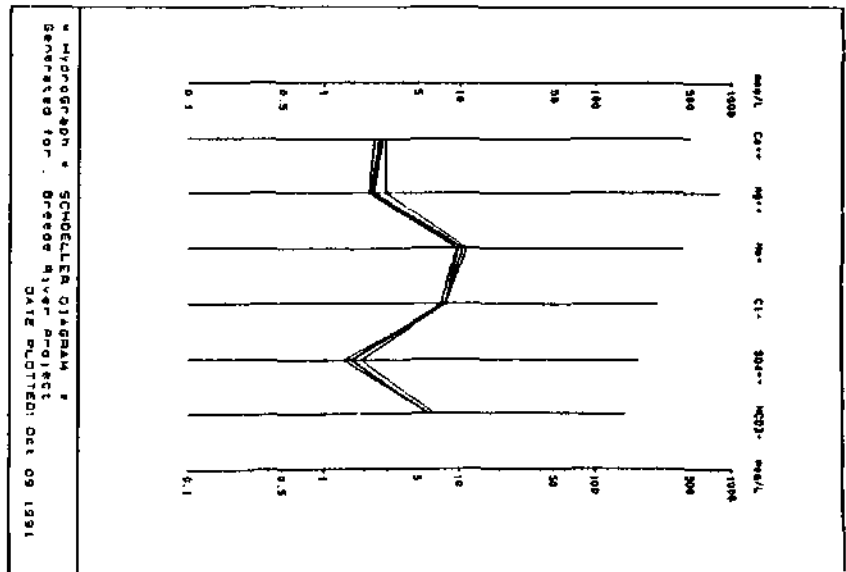
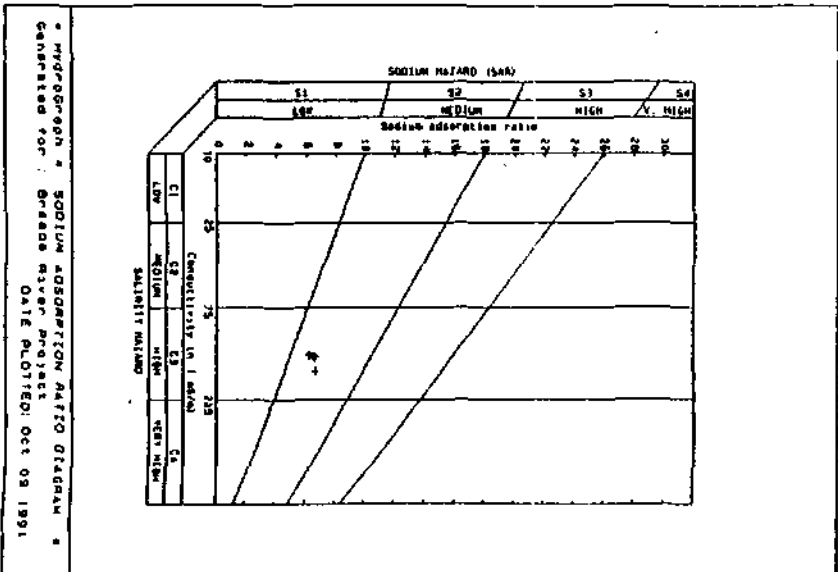

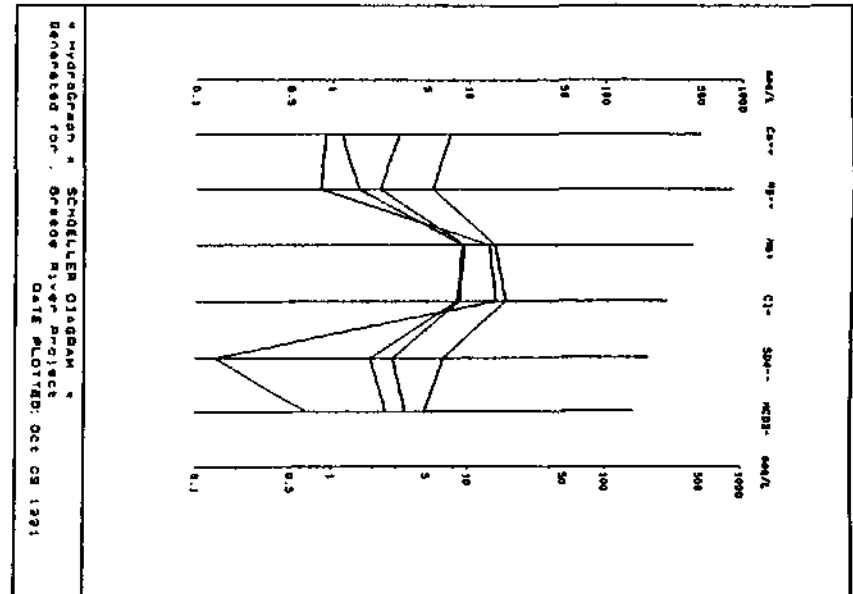
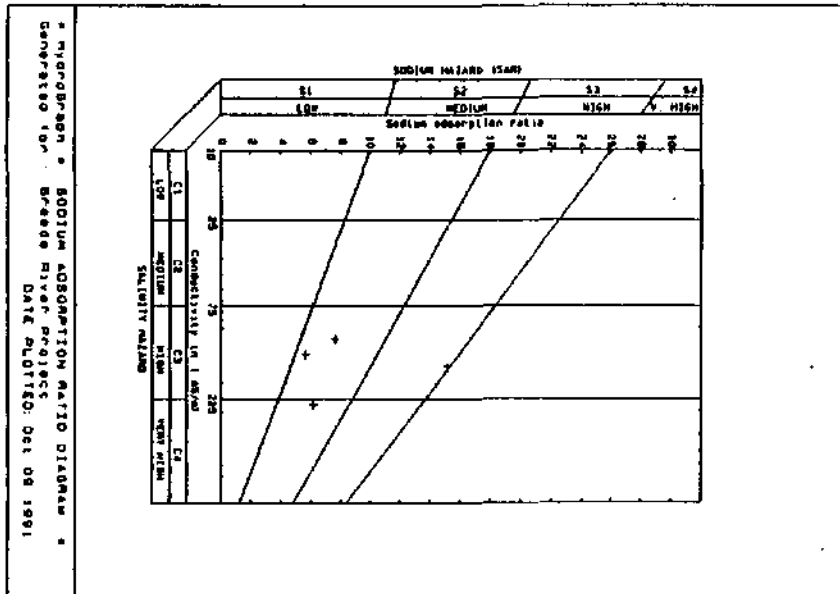
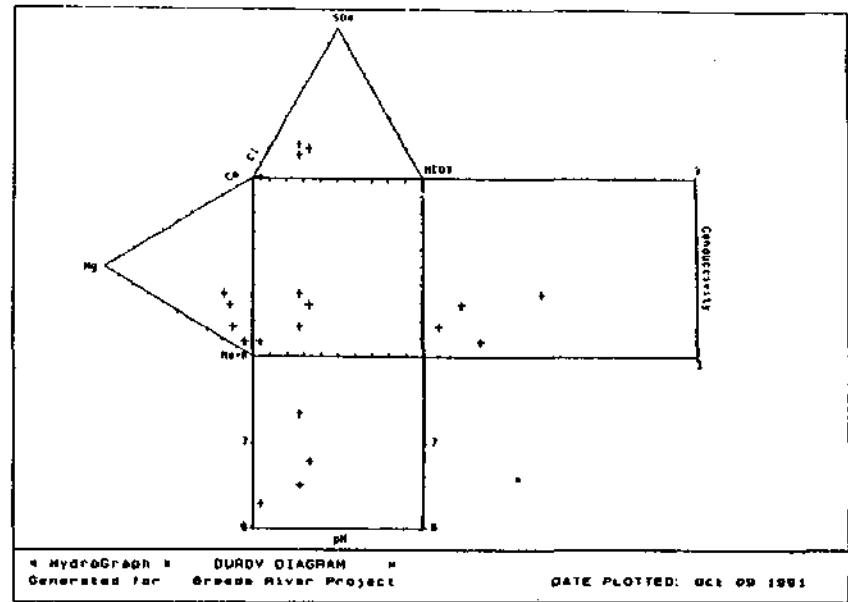
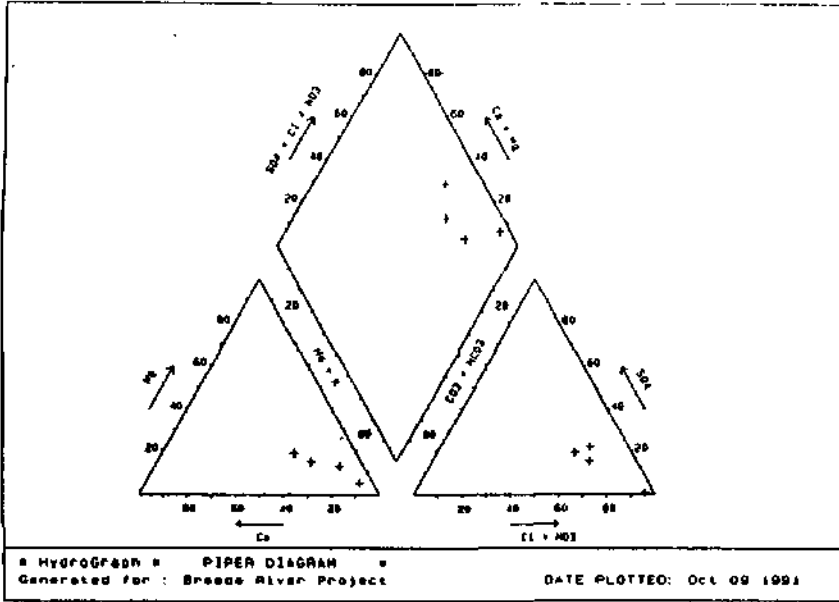

Bokkeveld 3319DD00053

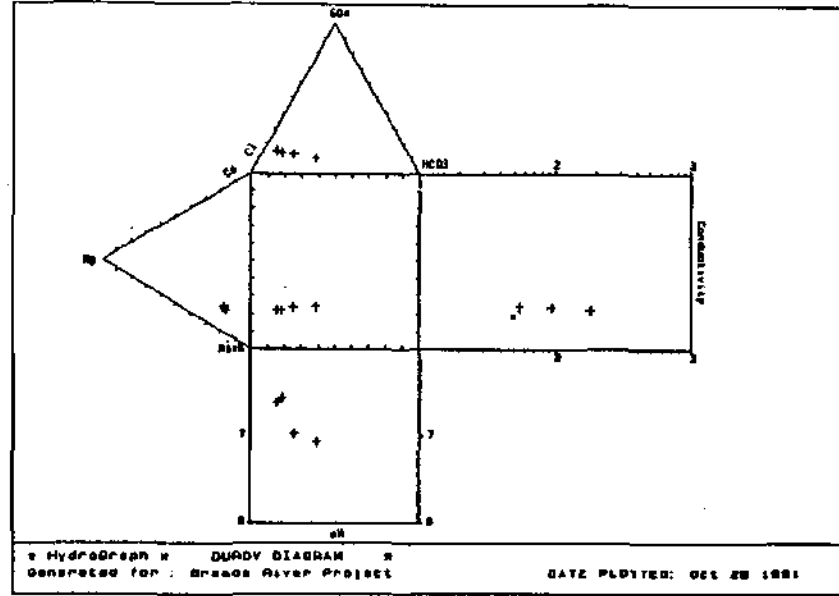
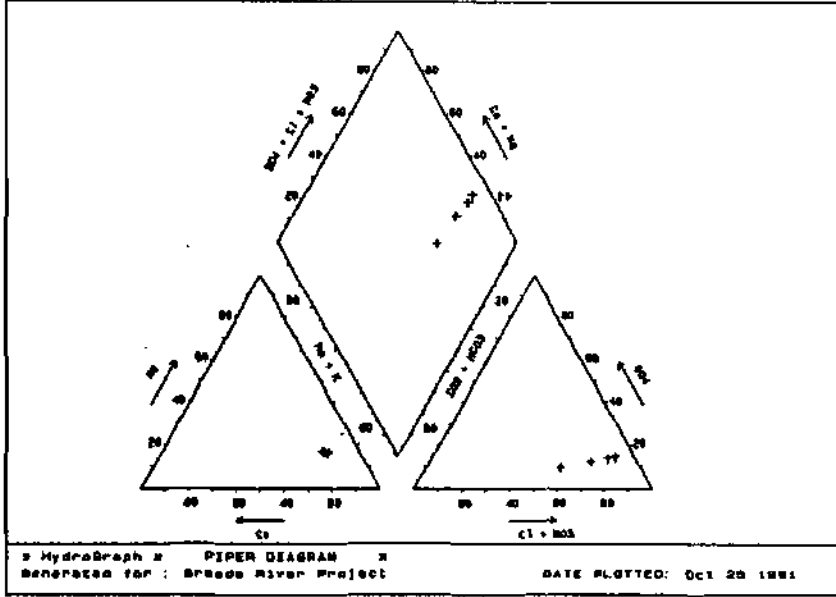

259

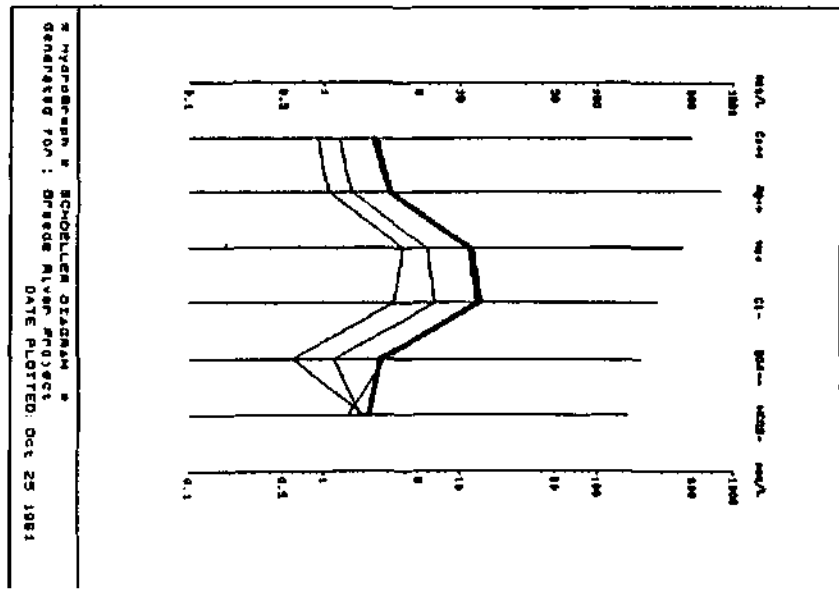
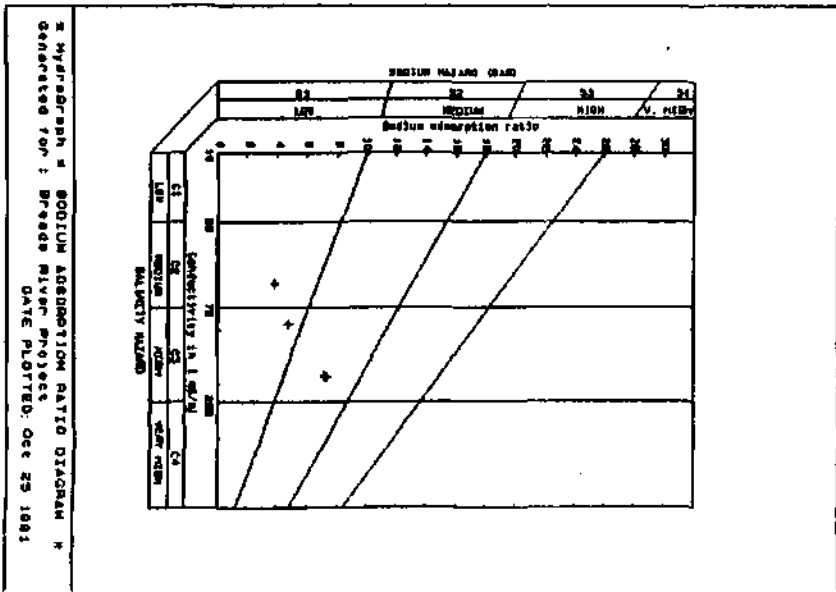

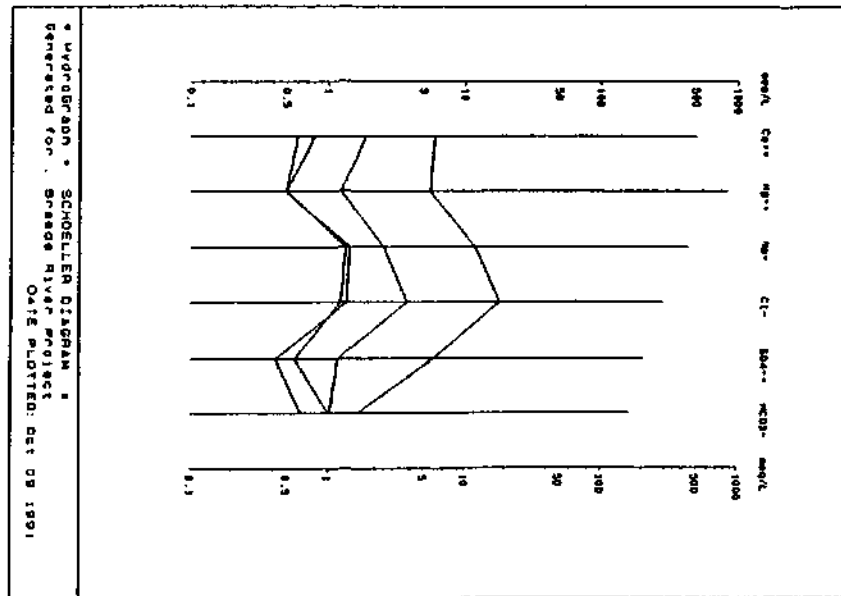
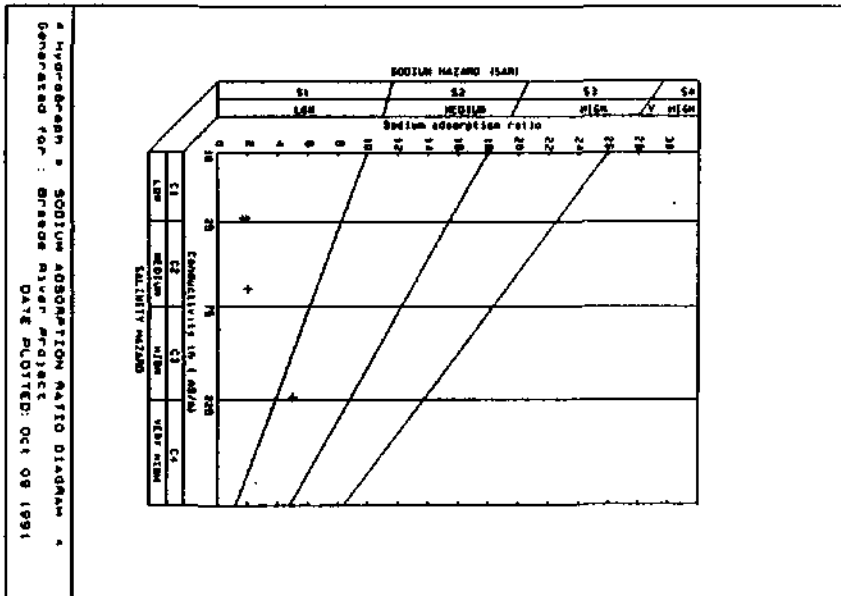
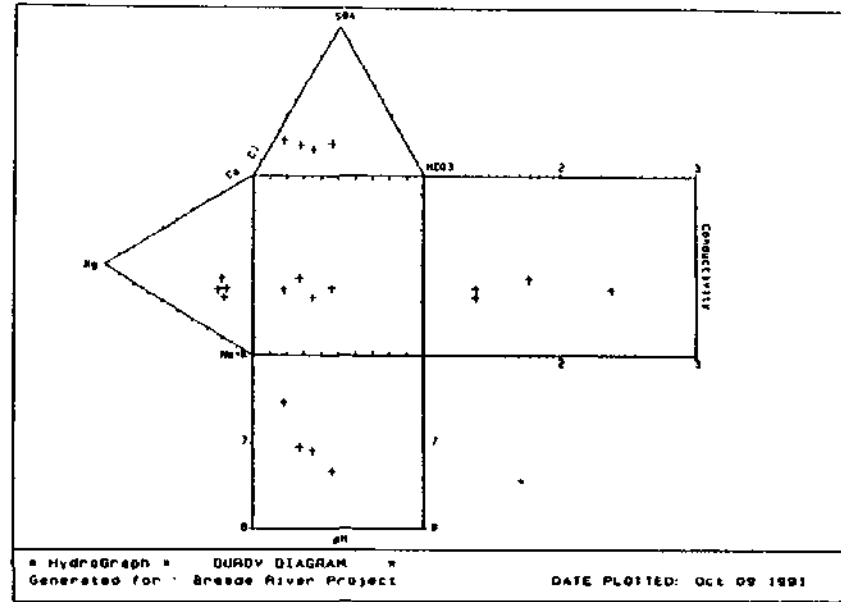
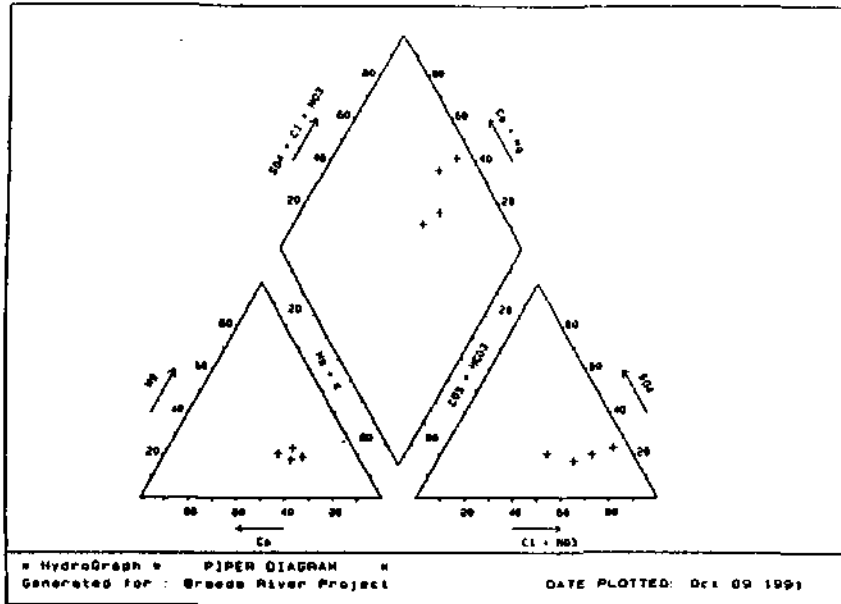

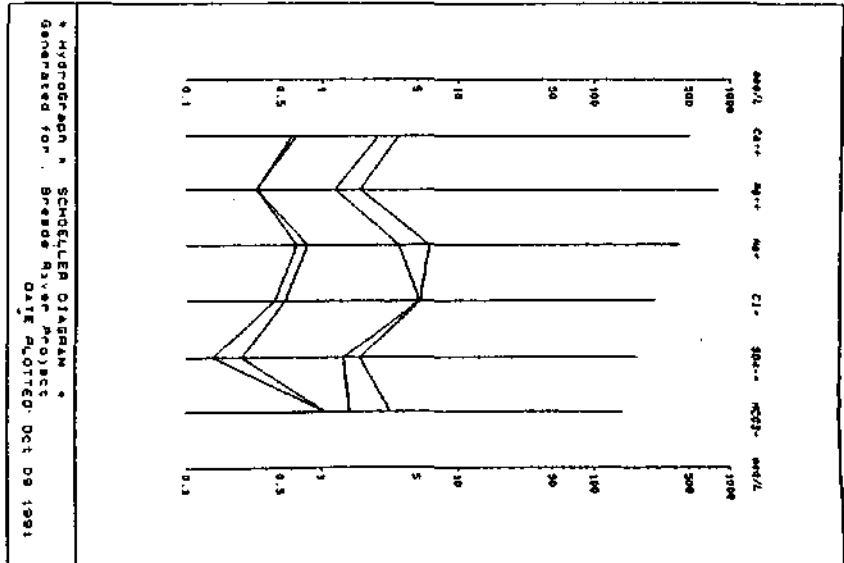
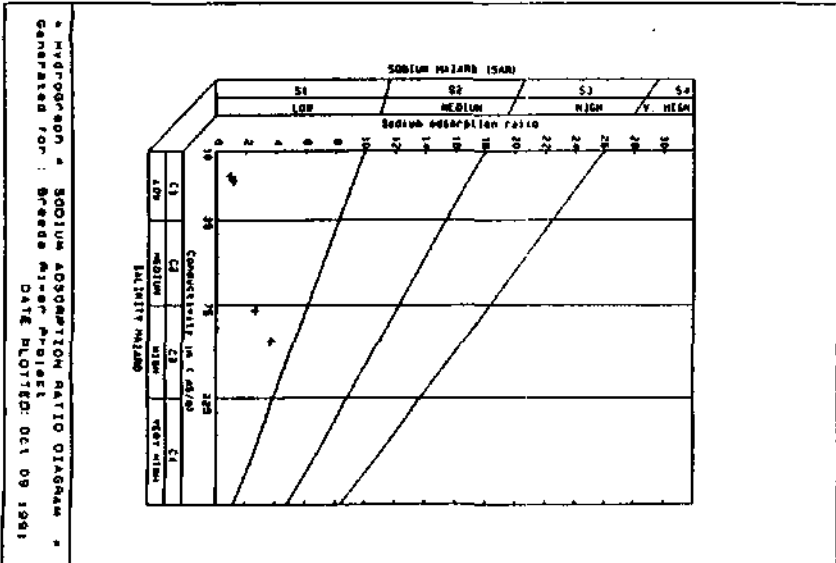
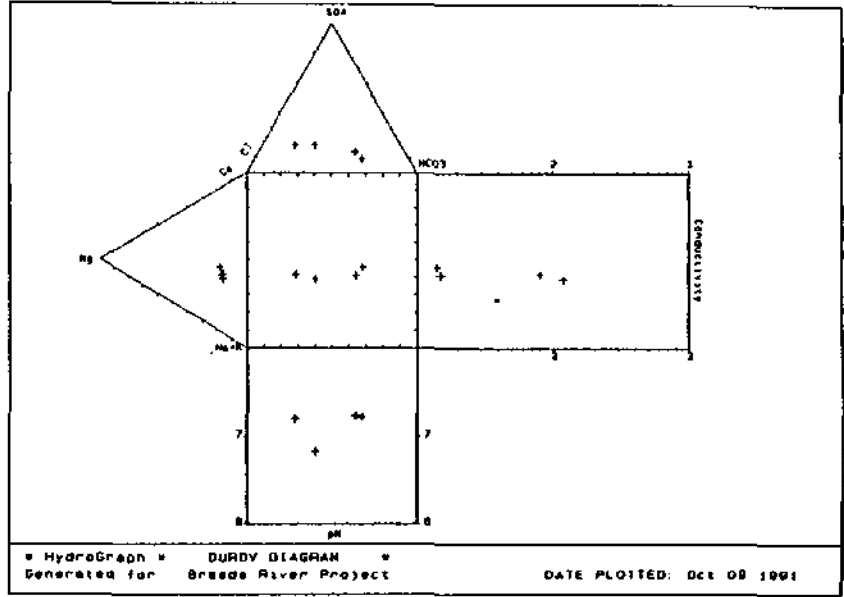
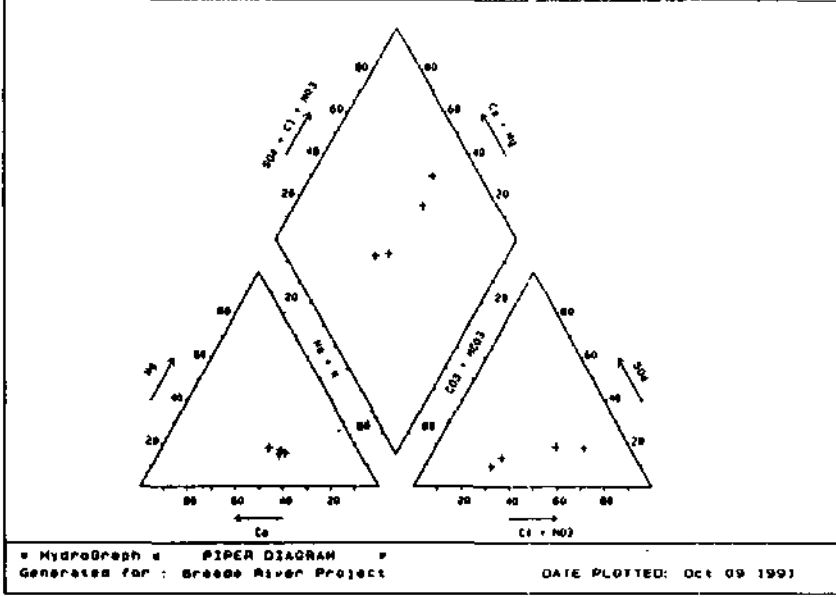

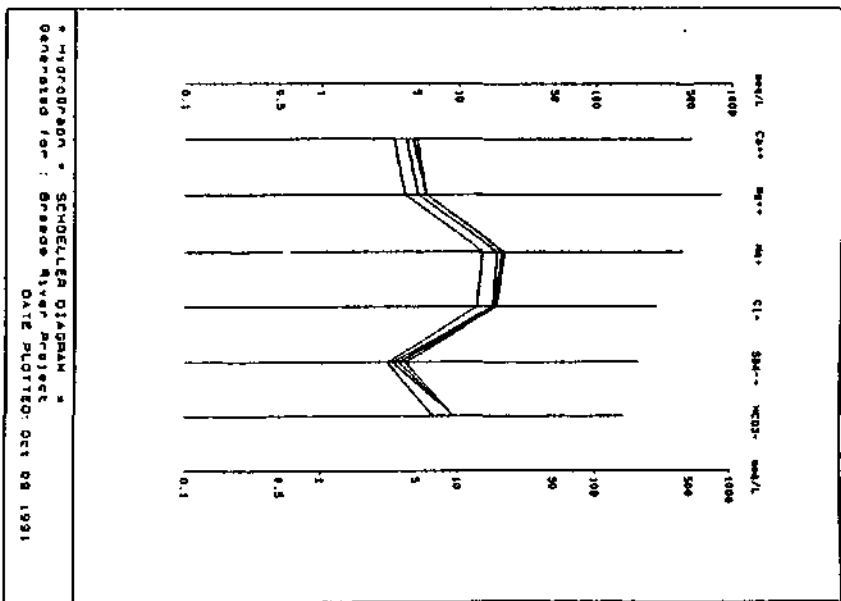
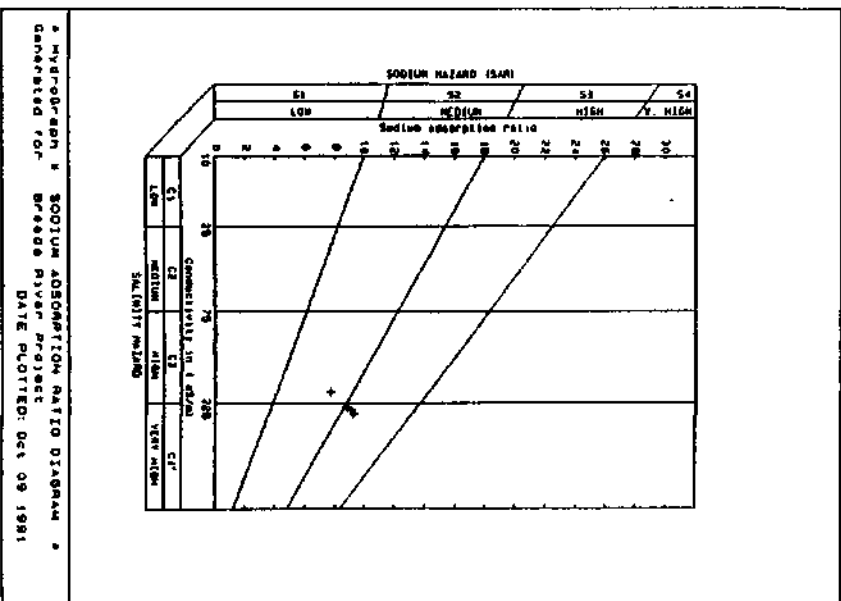
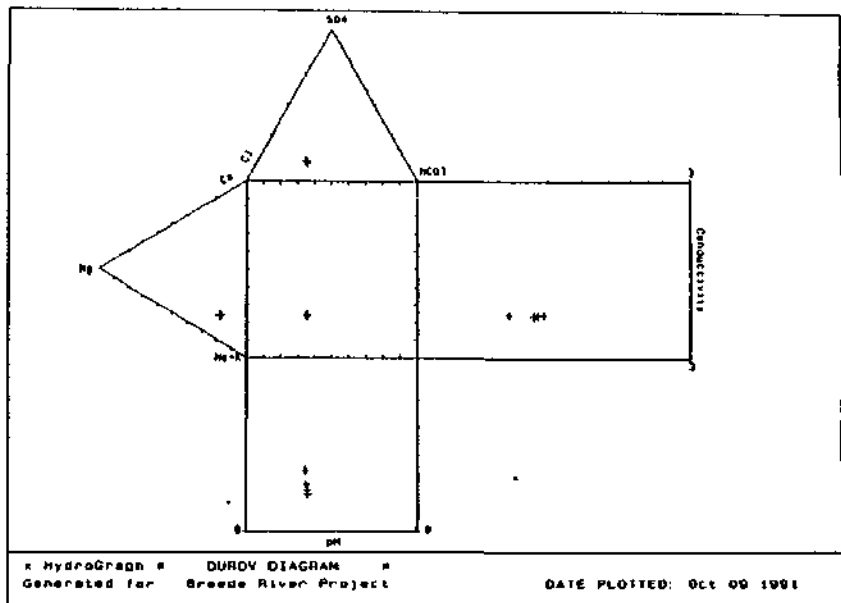
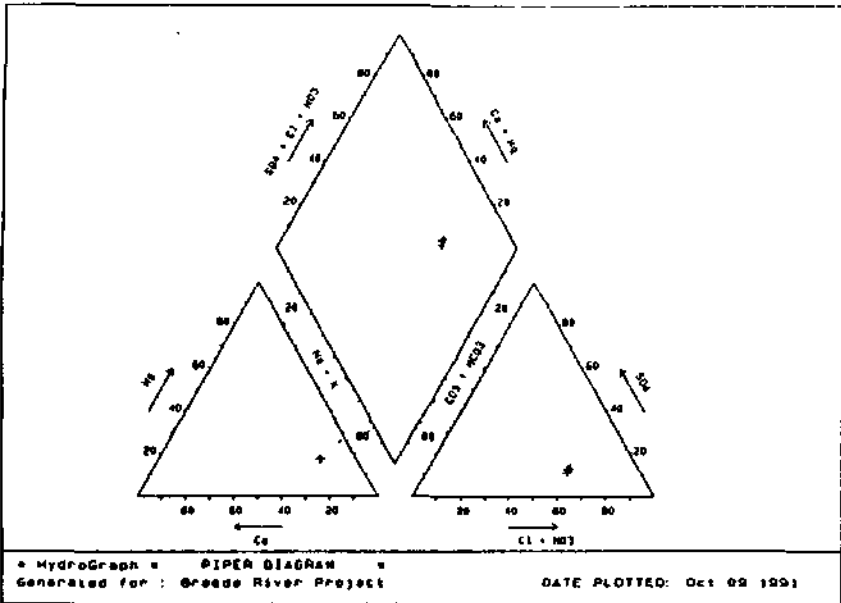

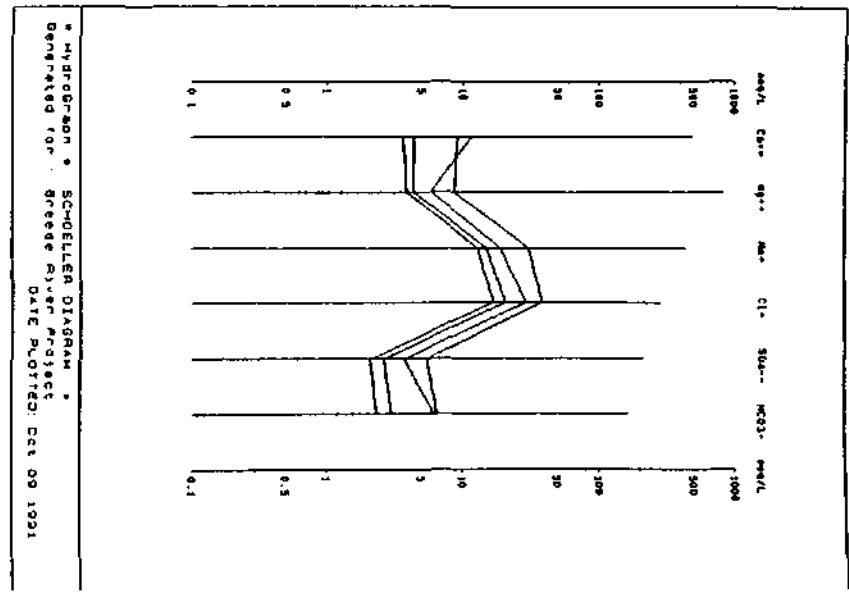
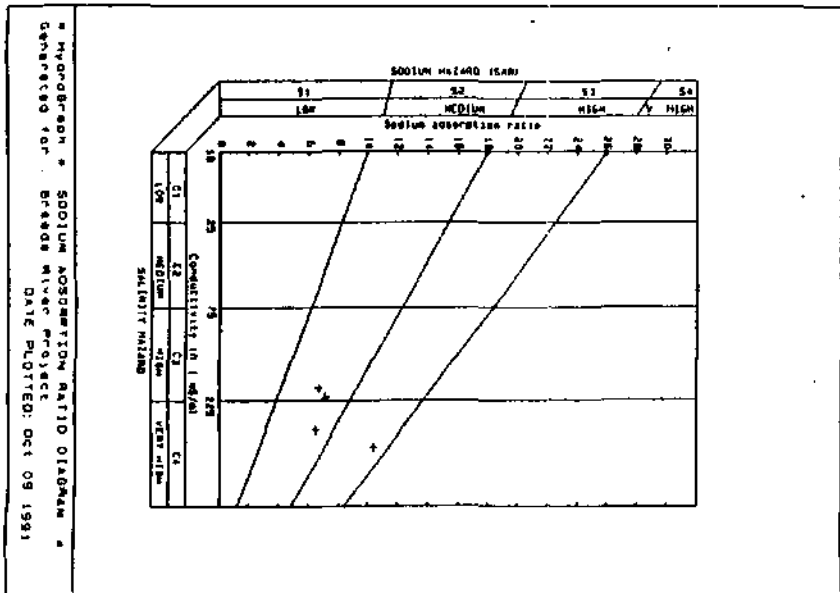
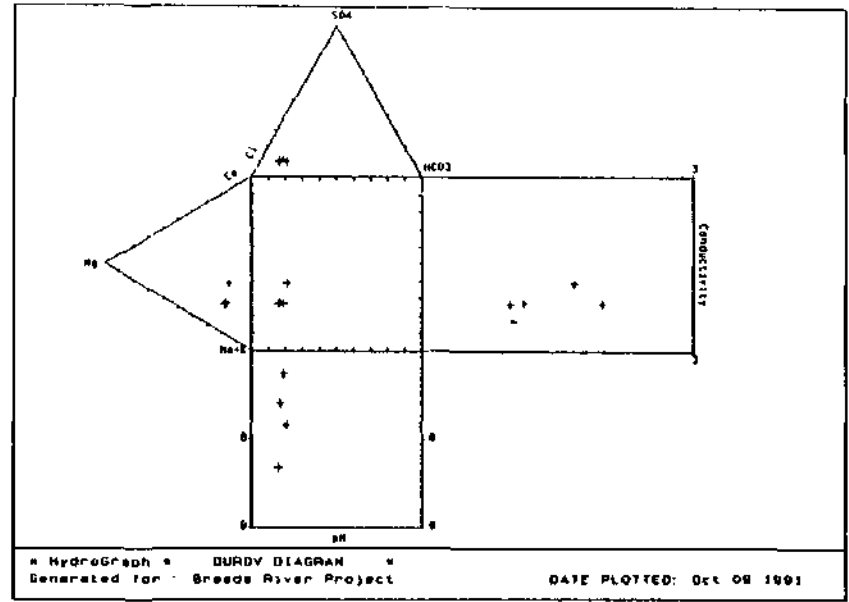
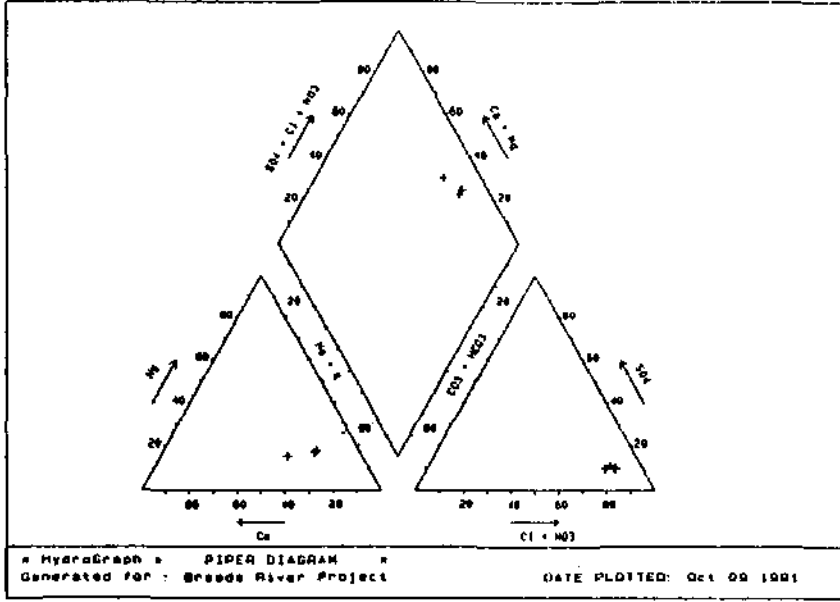

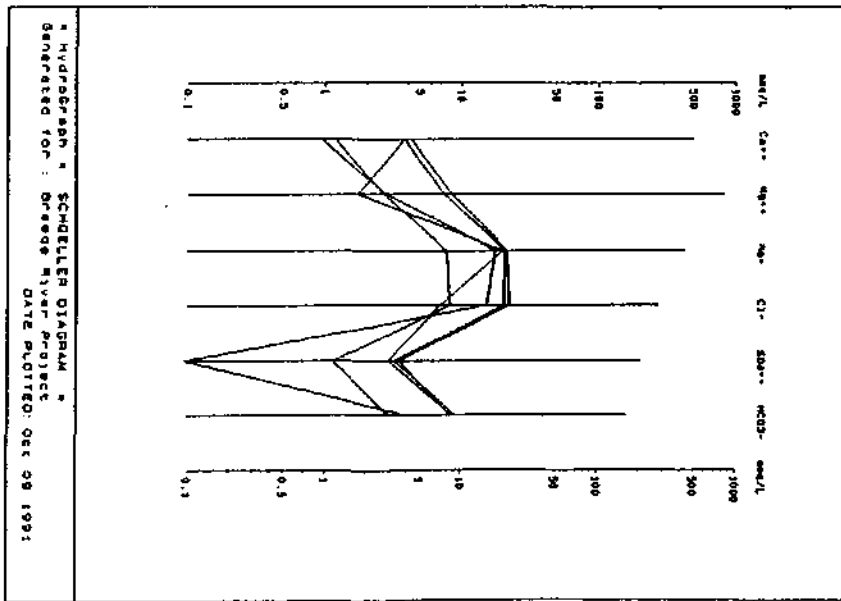
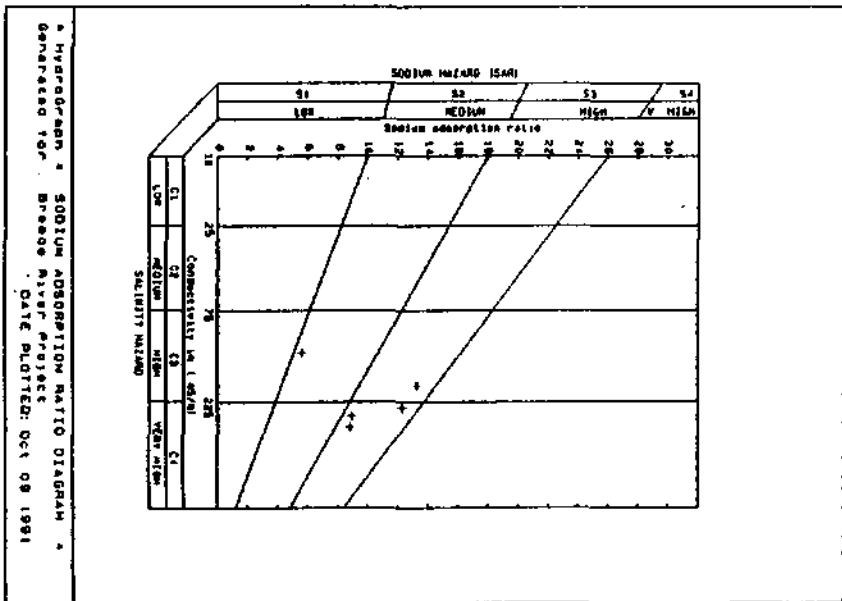
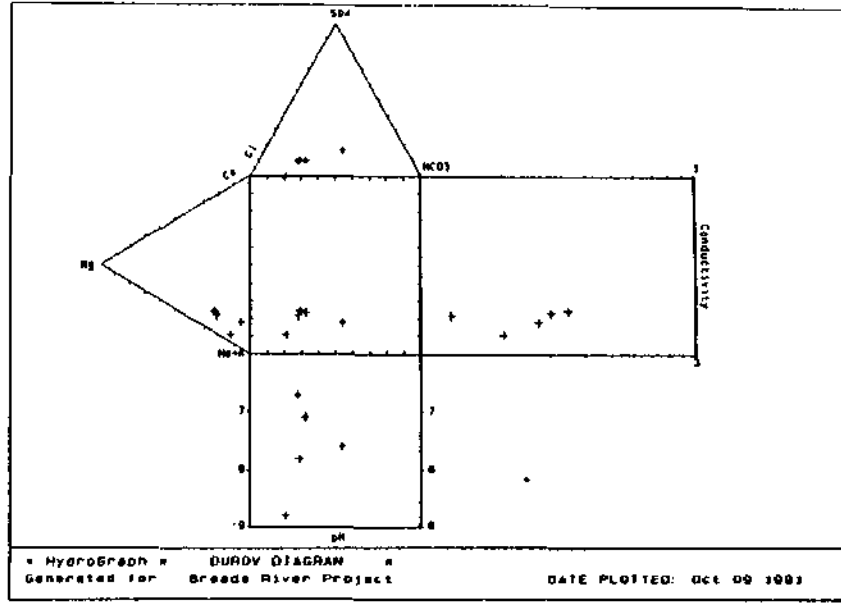
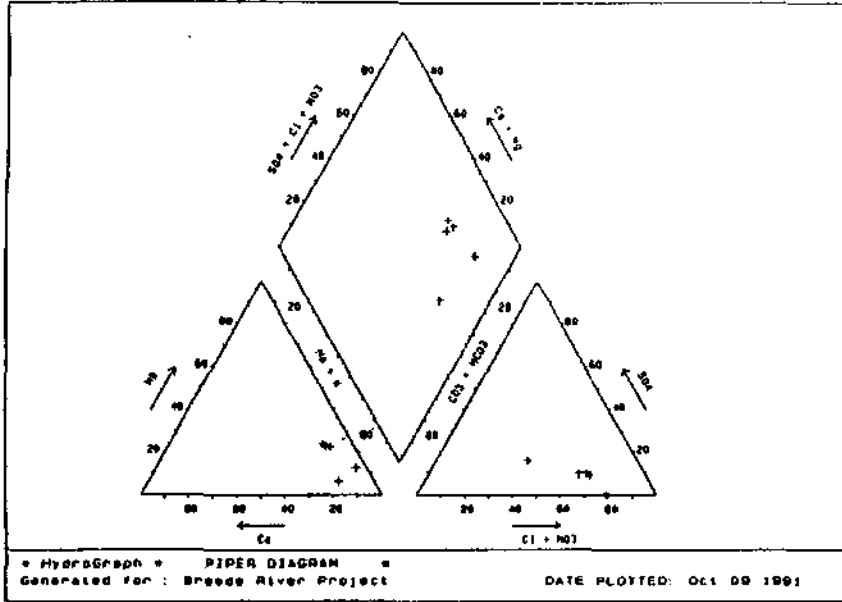

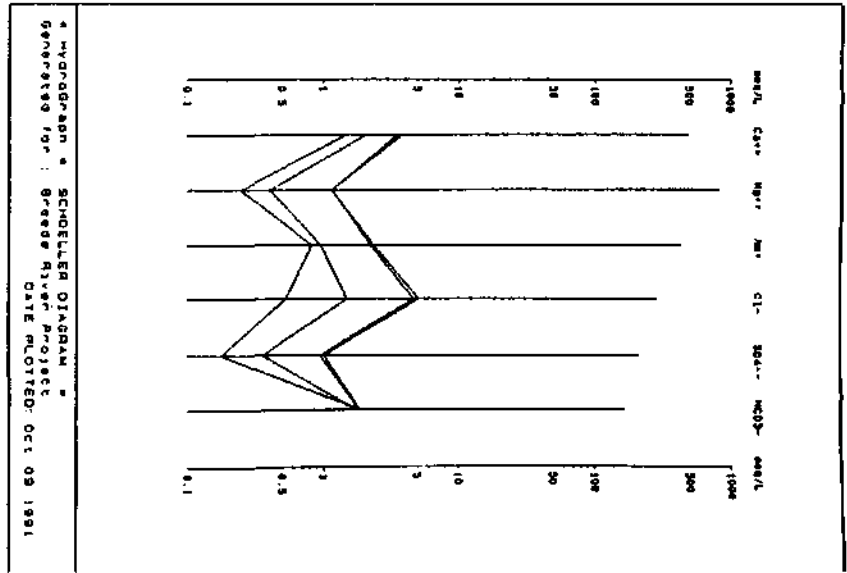
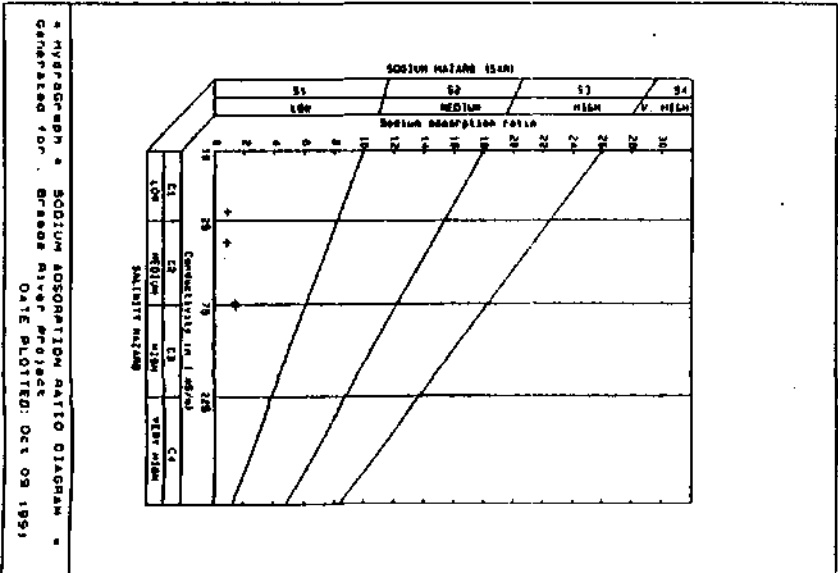
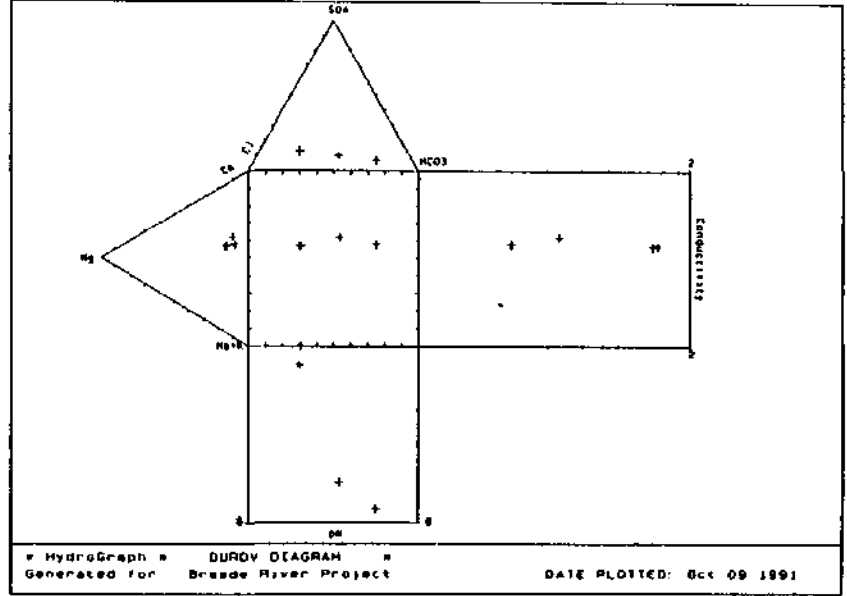
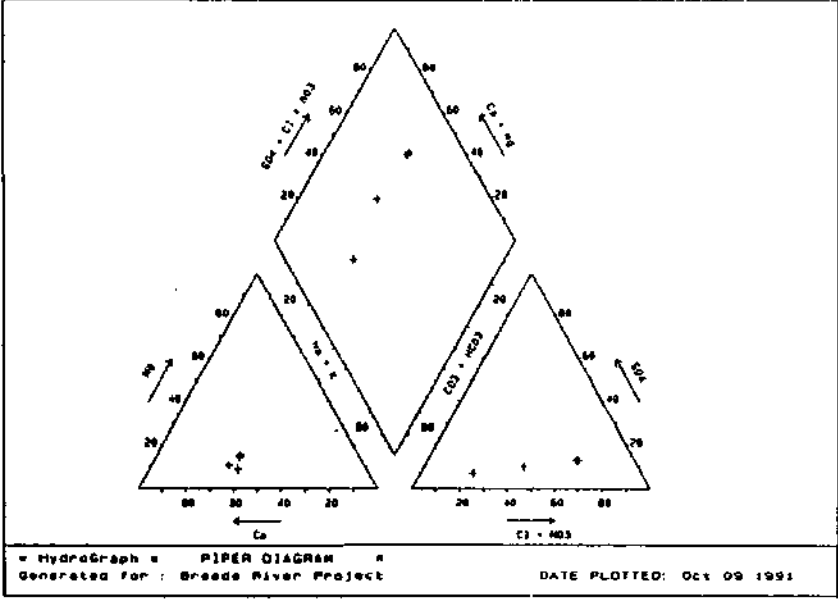

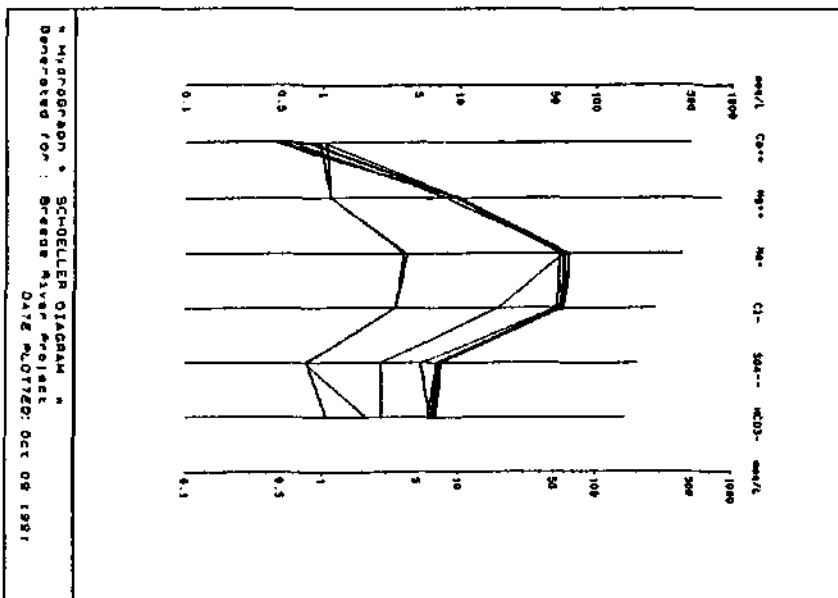
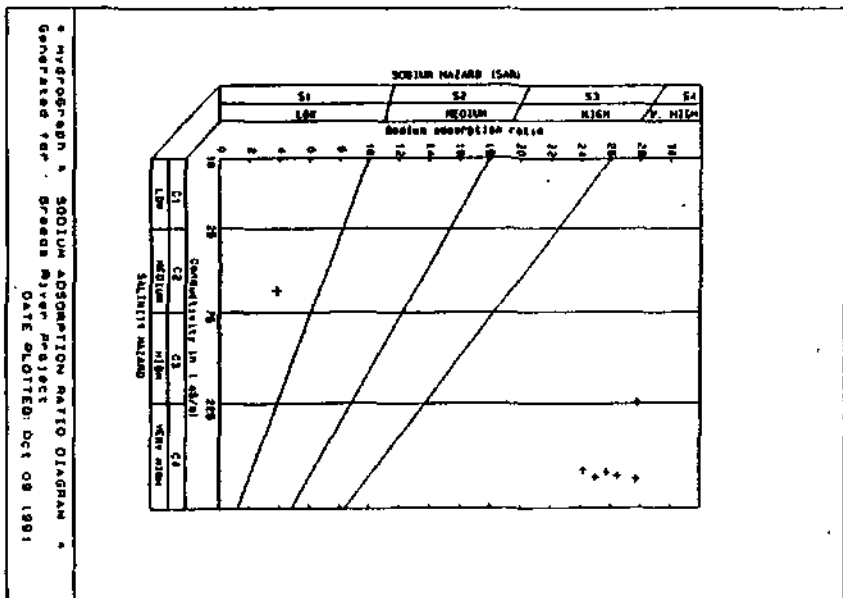
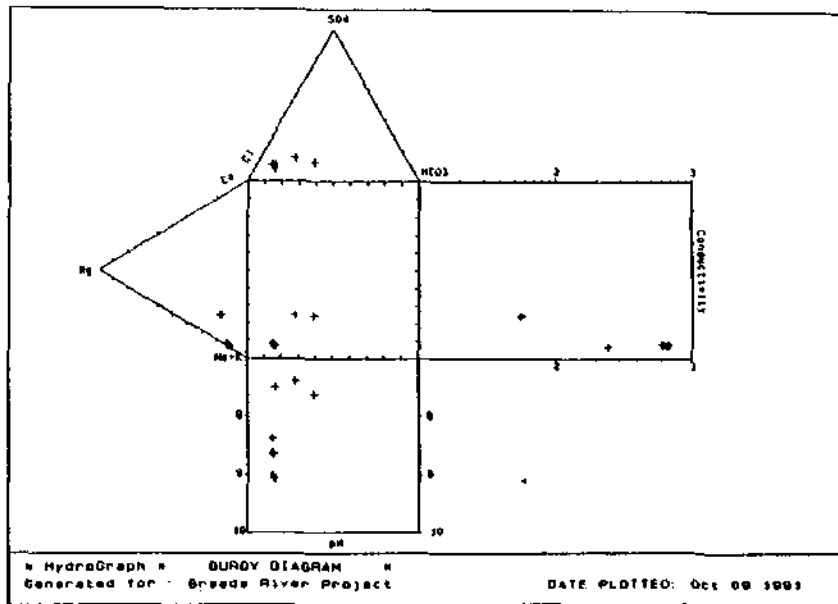
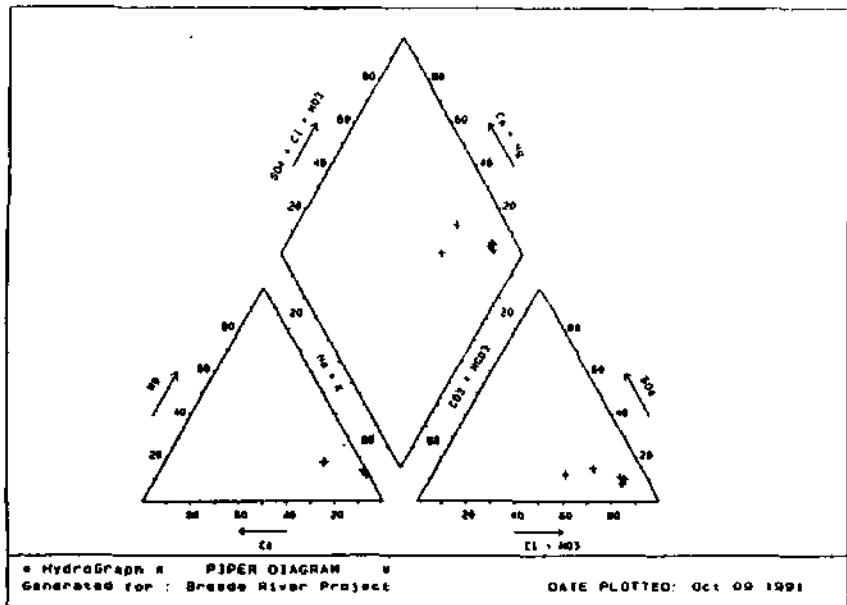

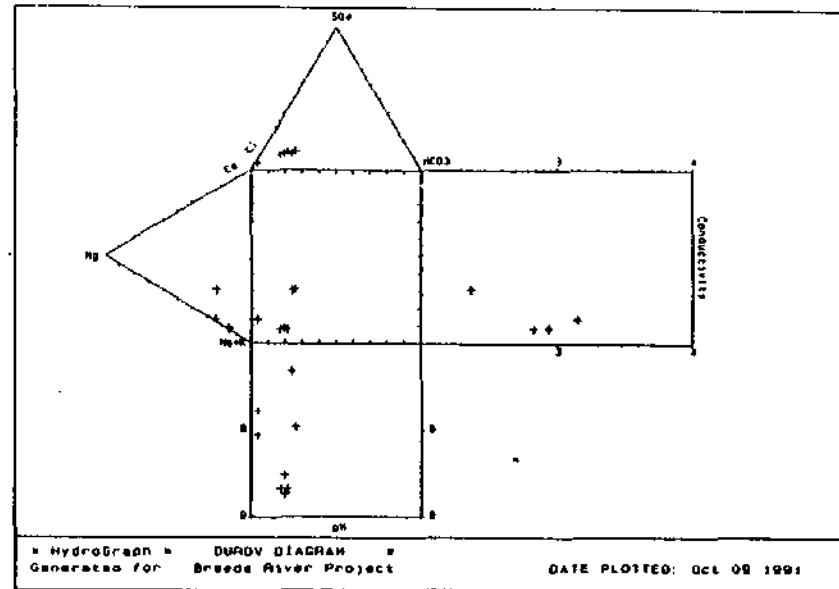
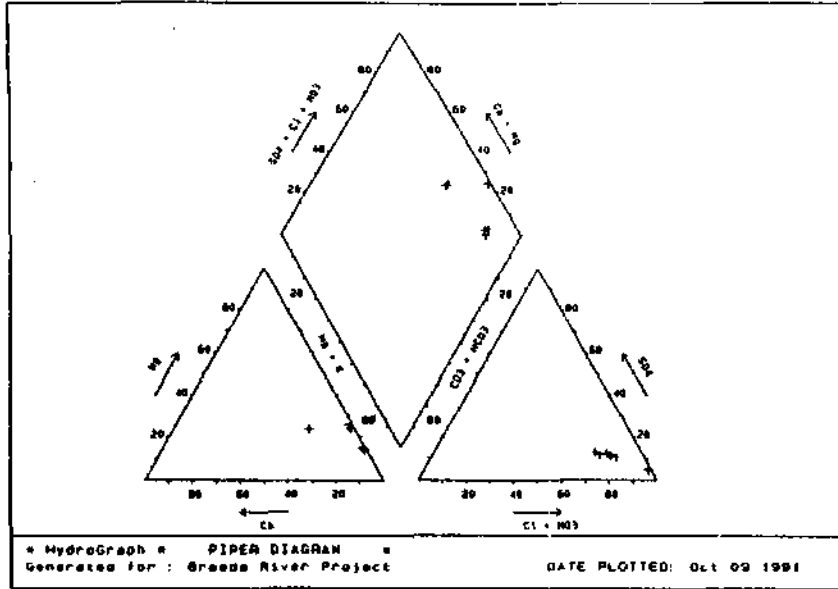

267

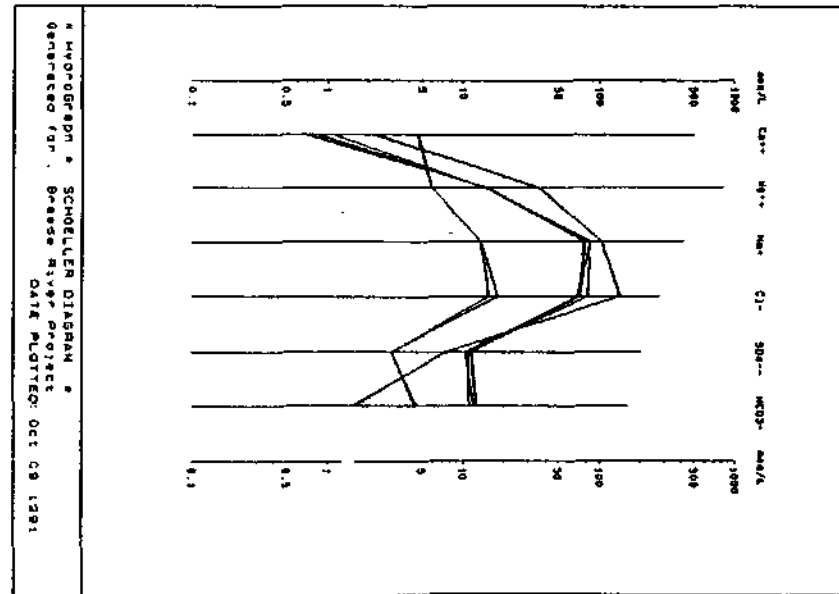
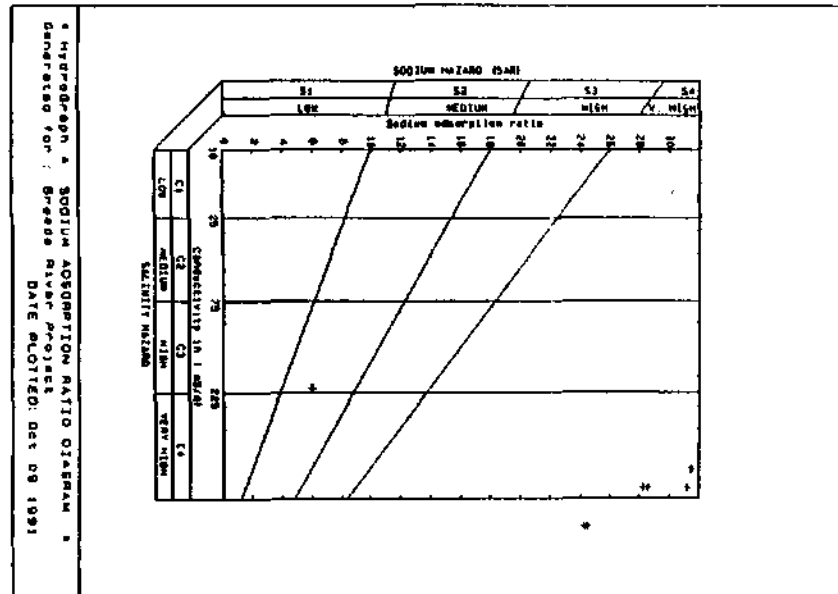

BOKKEVELD 3319DD01598

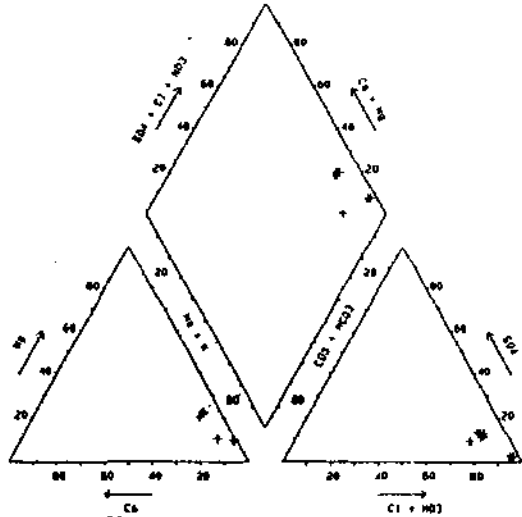

* HydroGraph * PIPER DIAGRAM *
Generated for : Breeds River Project

DATE PLOTTED: Oct 09 1991

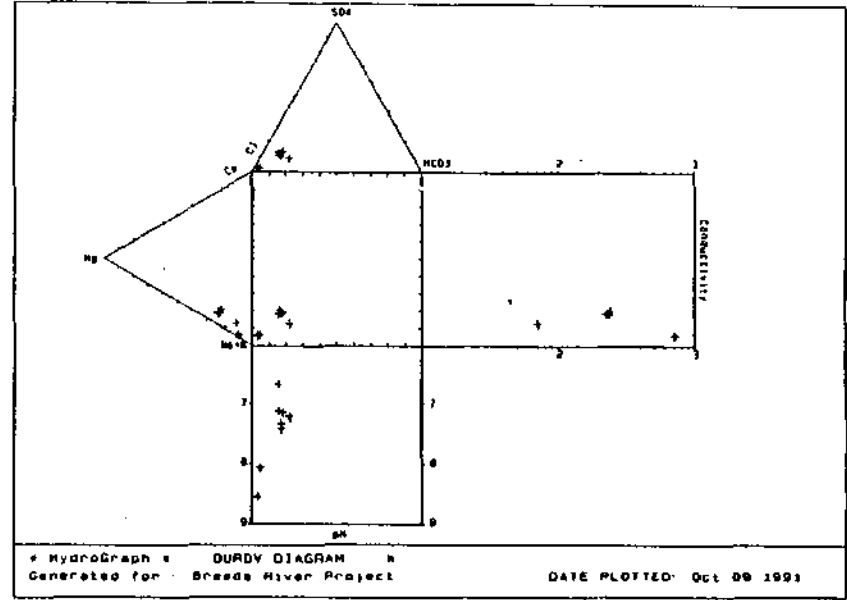

* HydroGraph * DURDY DIAGRAM *
Generated for : Breeds River Project

DATE PLOTTED: Oct 09 1991

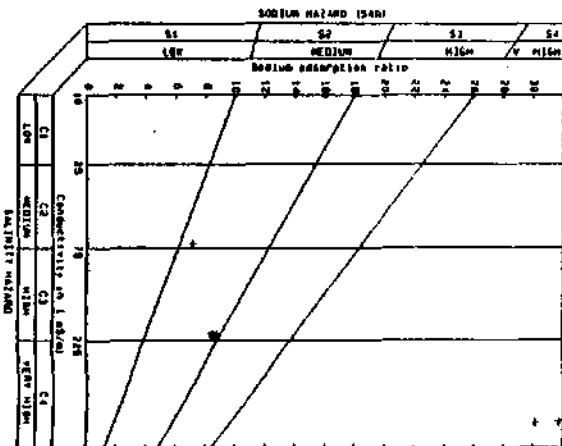

* HydroGraph * SODIUM HAZARD RATIO DIAGRAM *
Generated for : Breeds River Project
DATE PLOTTED: Oct 09 1991

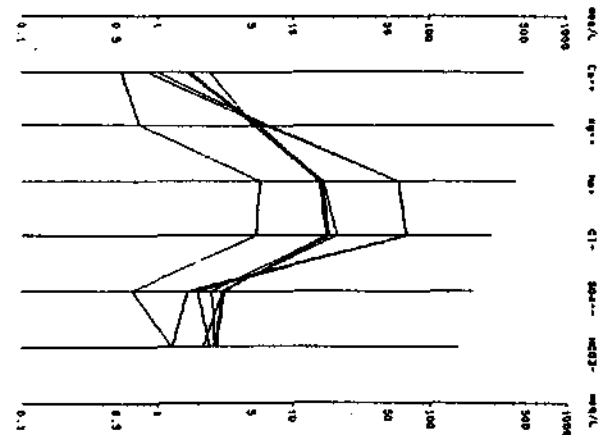

* HydroGraph * SCHOLLER DIAGRAM *
Generated for : Breeds River Project
DATE PLOTTED: Oct 09 1991

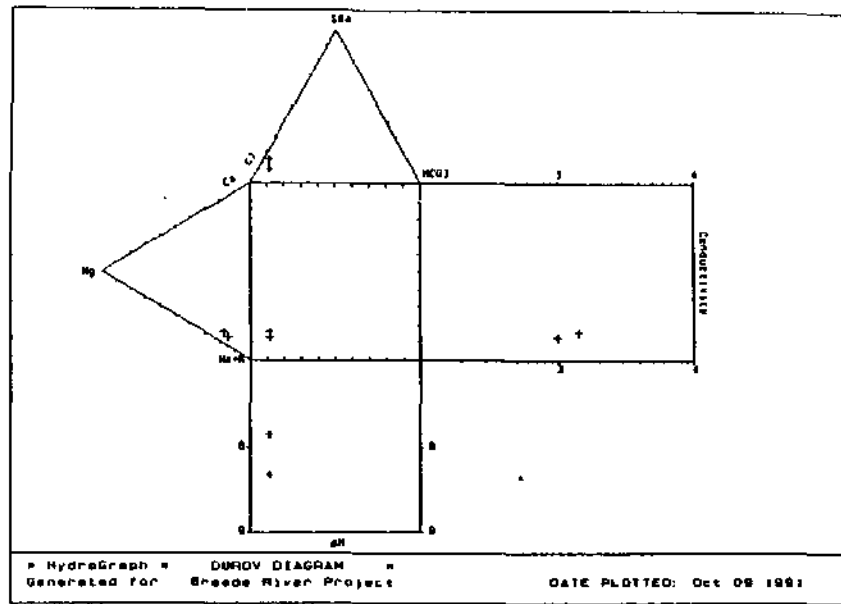
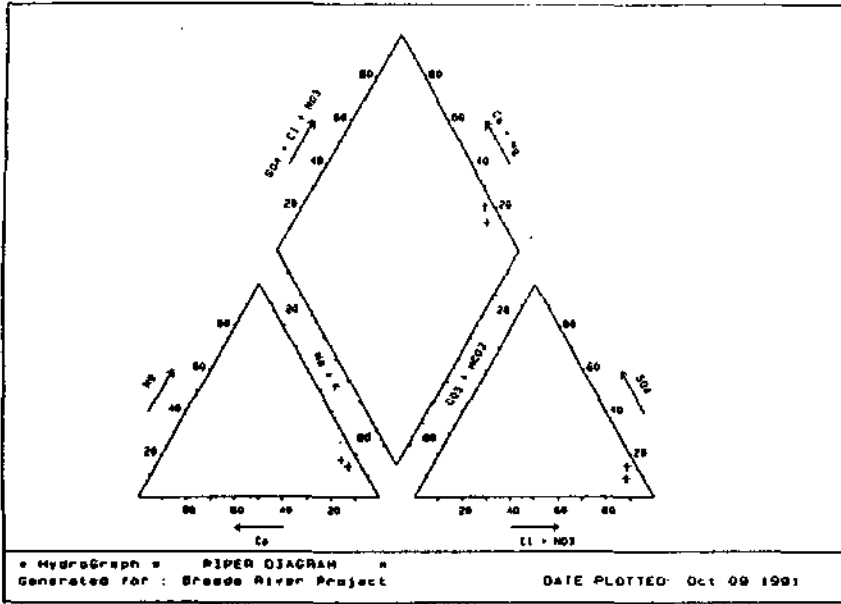

269

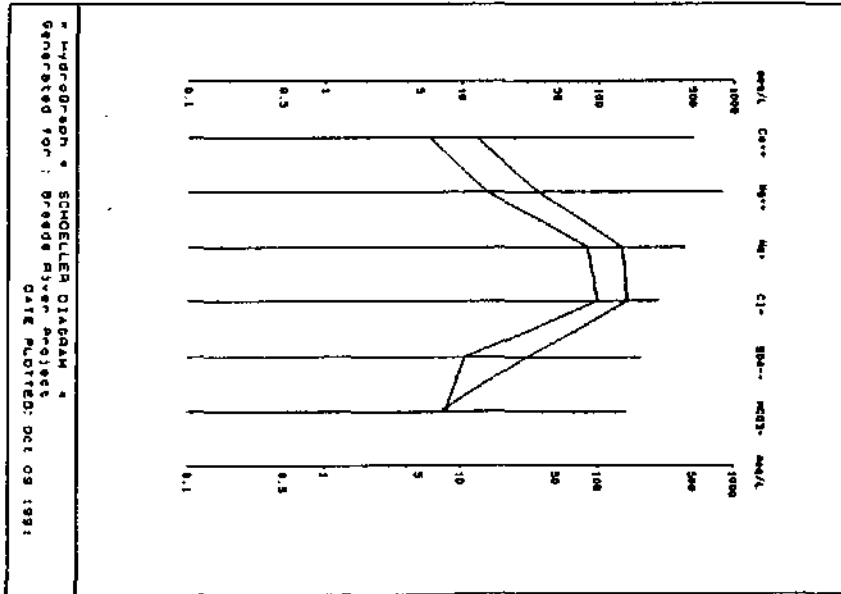
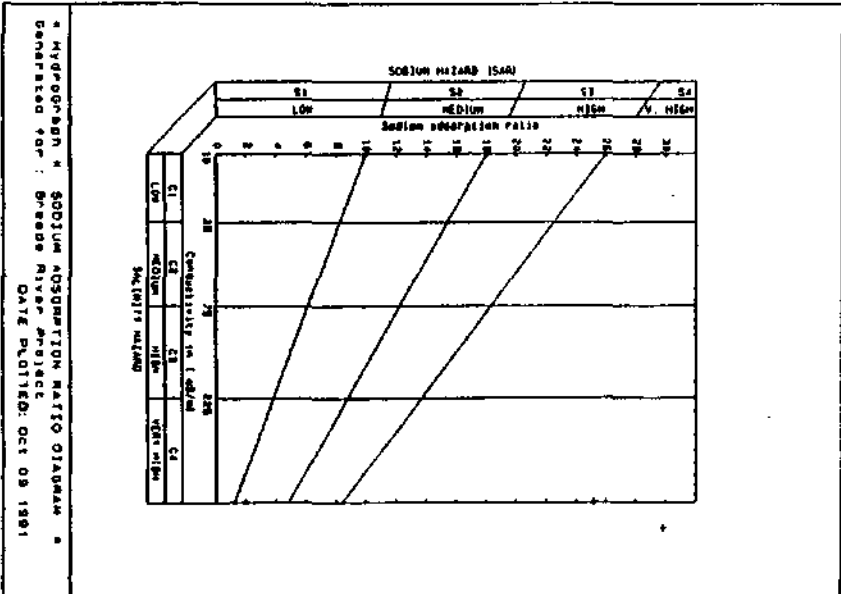

BOKKEVELD 3319DD01600

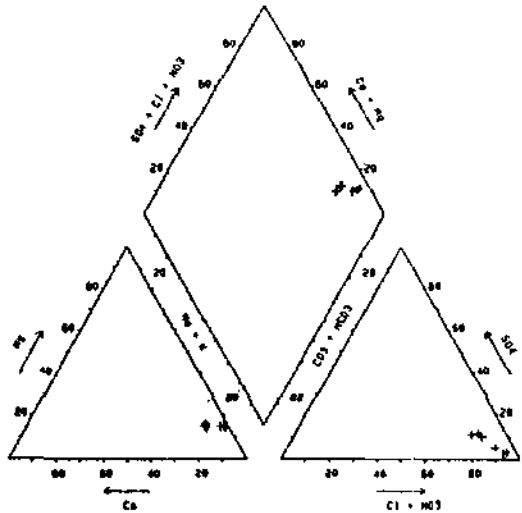

HydroGraph - PIPER DIAGRAM
Generated for : Breede River Project
DATE PLOTTED: Oct 09 1991

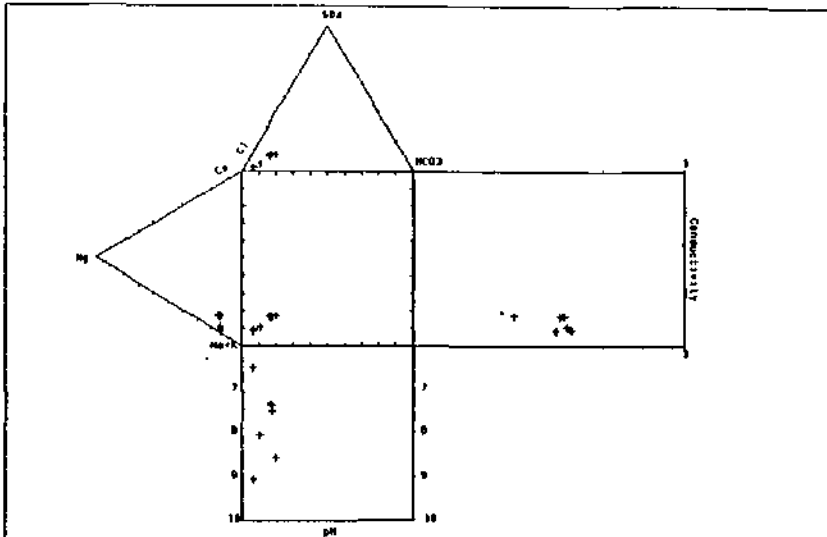

HydroGraph - DURDY DIAGRAM
Generated for : Breede River Project
DATE PLOTTED: Oct 09 1991

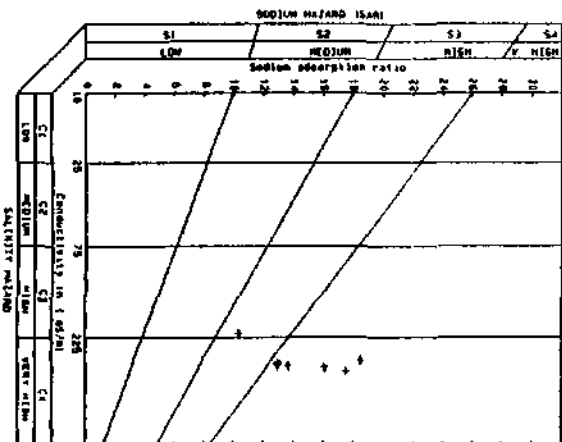

HydroGraph - SODIUM ADSORPTION RATIO DIAGRAM
Generated for : Breede River Project
DATE PLOTTED: Oct 09 1991

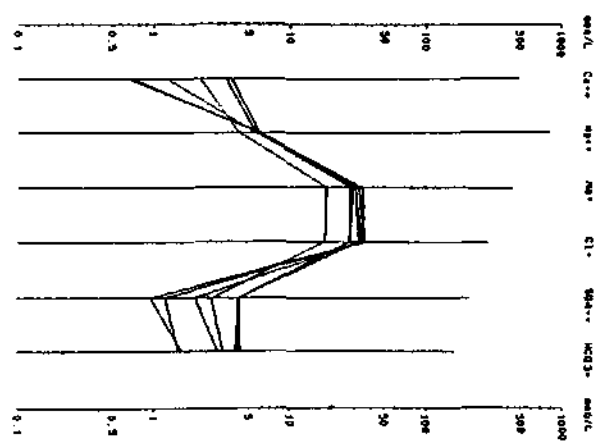

HydroGraph - SCHOLLER DIAGRAM
Generated for : Breede River Project
DATE PLOTTED: Oct 09 1991

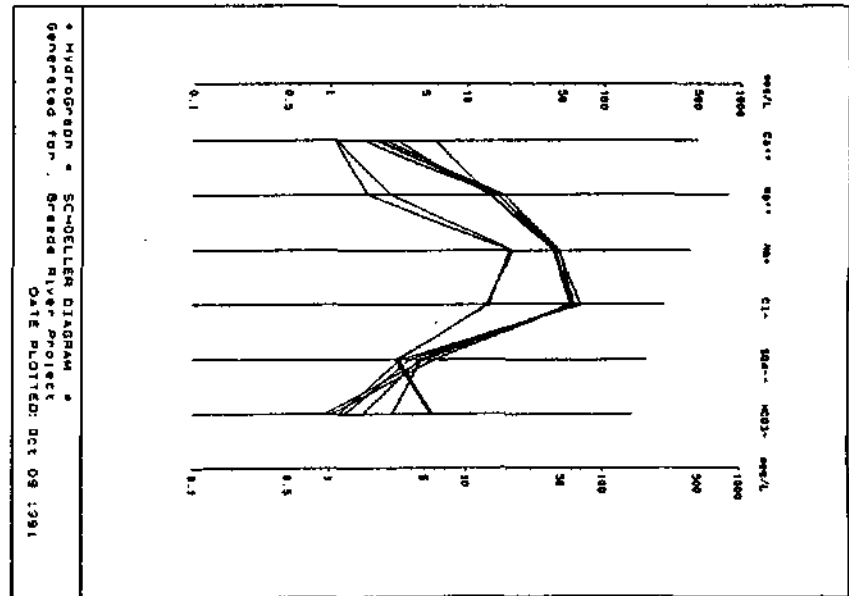
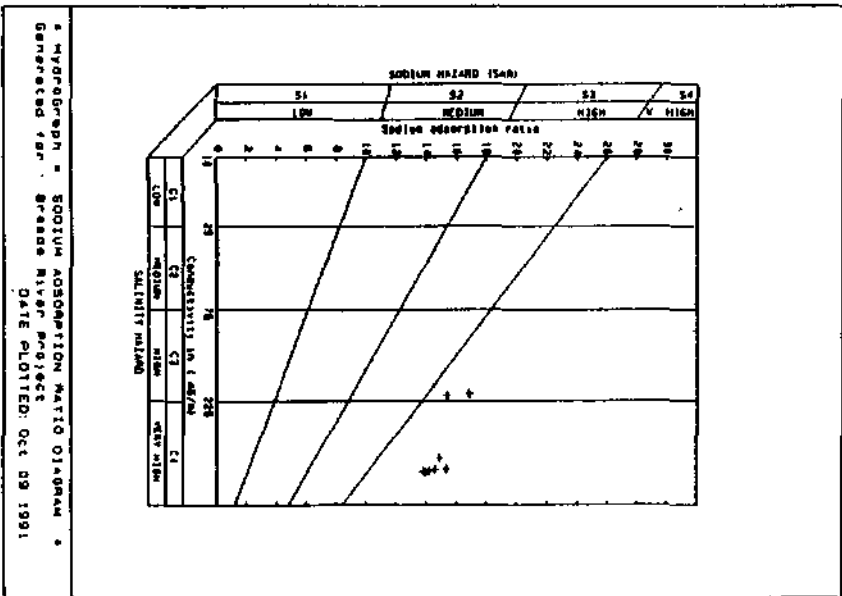
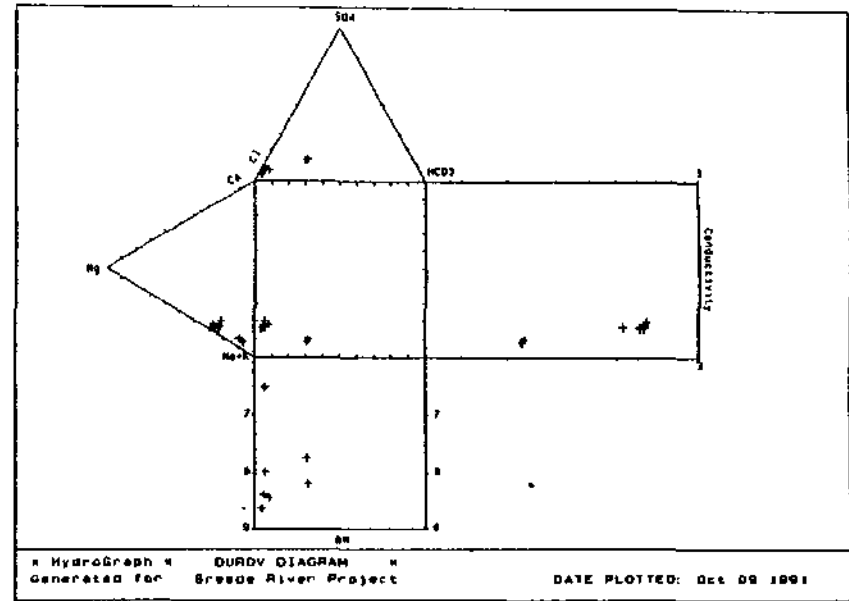
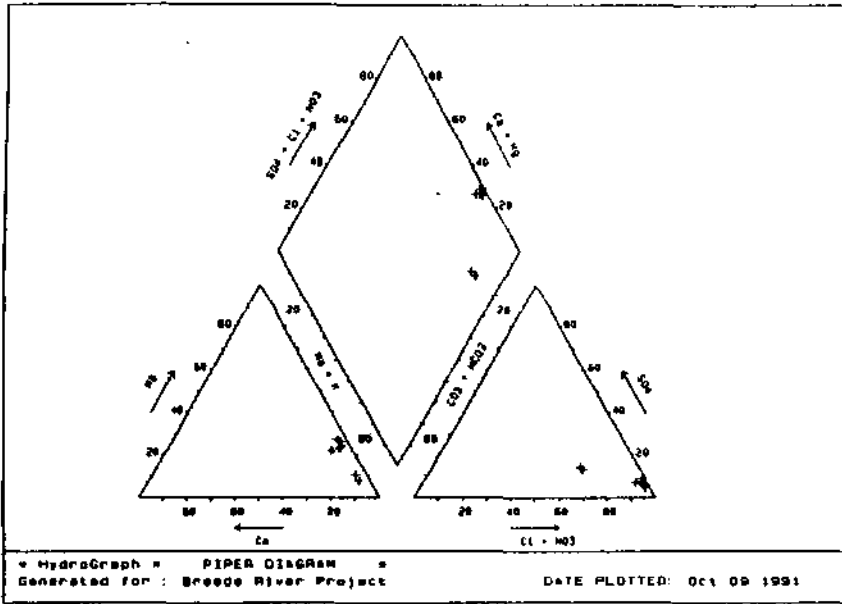

BOKKEVELD 3319DD1602

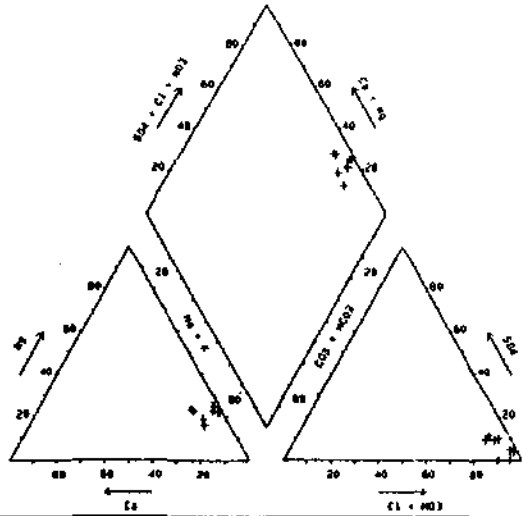

* HydroGraph * PIPER DIAGRAM *
Generated for : Breeds River Project

DATE PLOTTED: Oct 09 1991

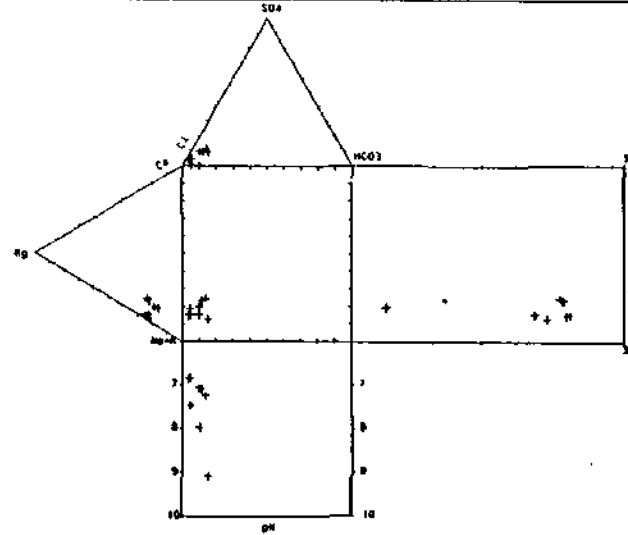

* HydroGraph * DUREY DIAGRAM *
Generated for : Breeds River Project

DATE PLOTTED: Oct 09 1991

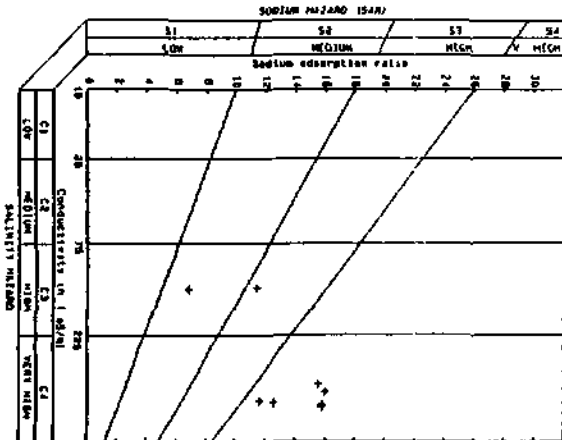

* HydroGraph * SODIUM ADSORPTION RATIO DIAGRAM *
Generated for : Breeds River Project
DATE PLOTTED: Oct 09 1991

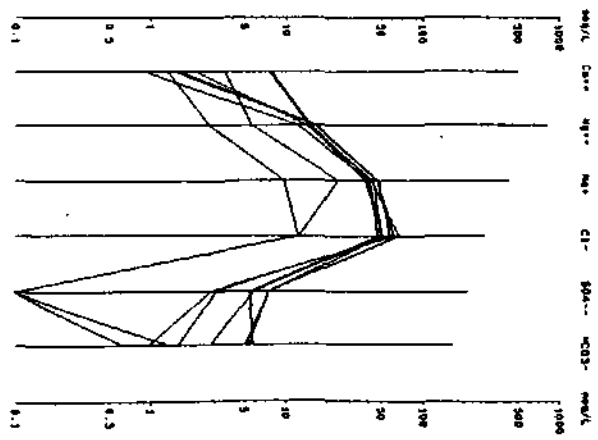

* HydroGraph * SCHUELLER DIAGRAM *
Generated for : Breeds River Project
DATE PLOTTED: Oct 09 1991

272

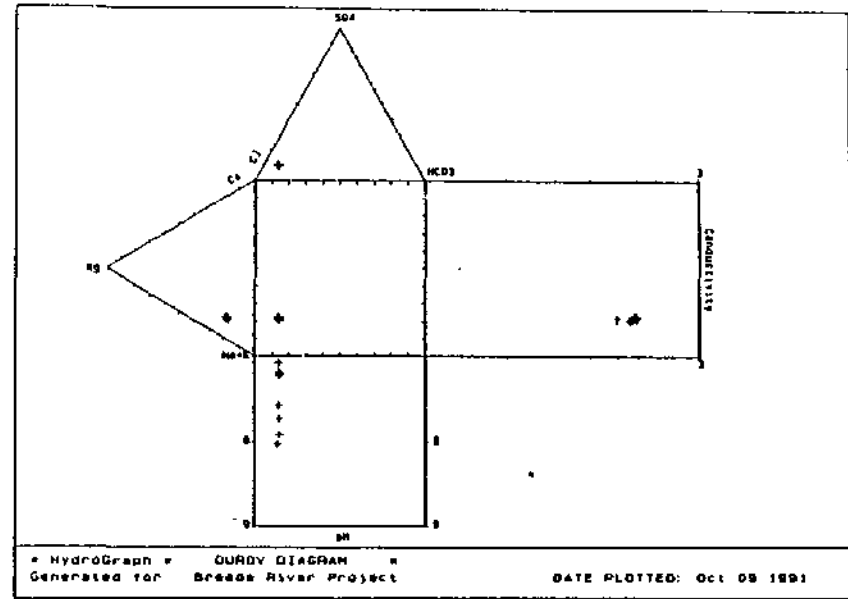
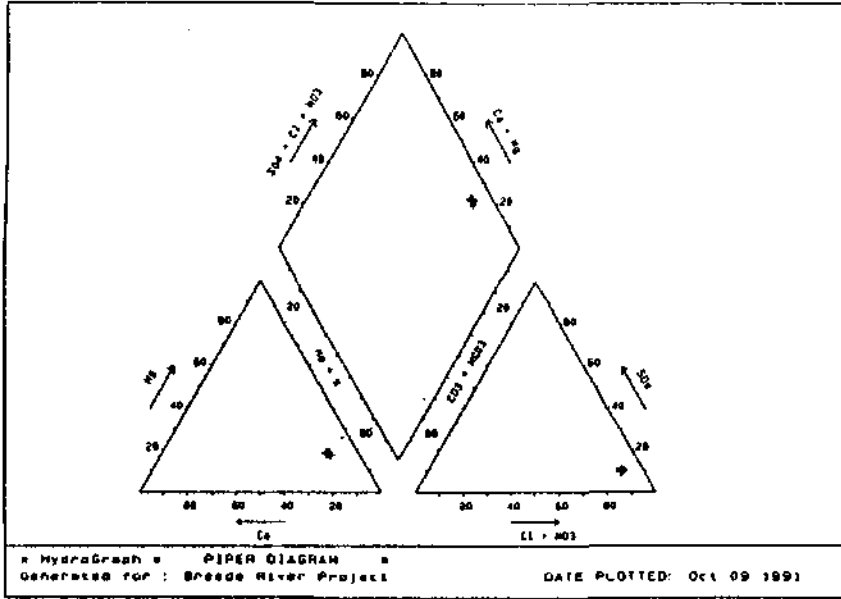

273

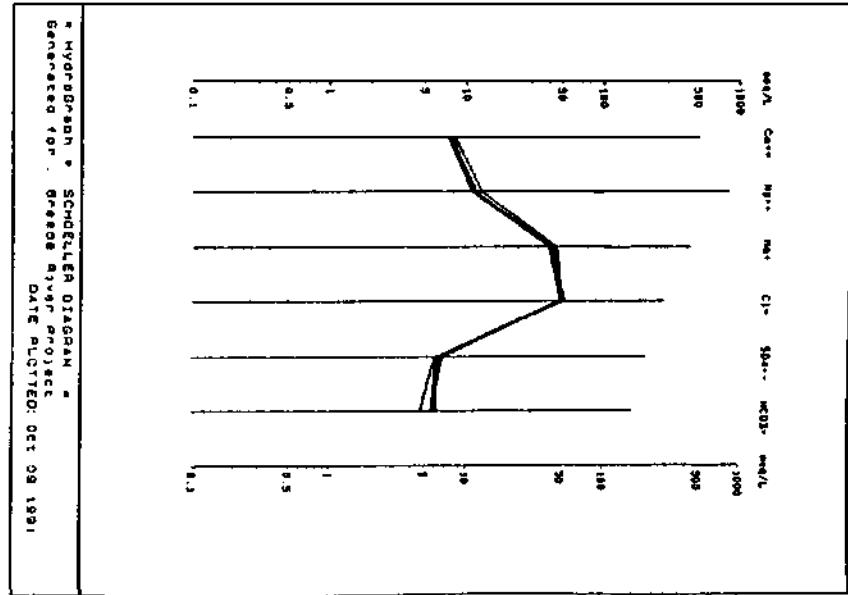
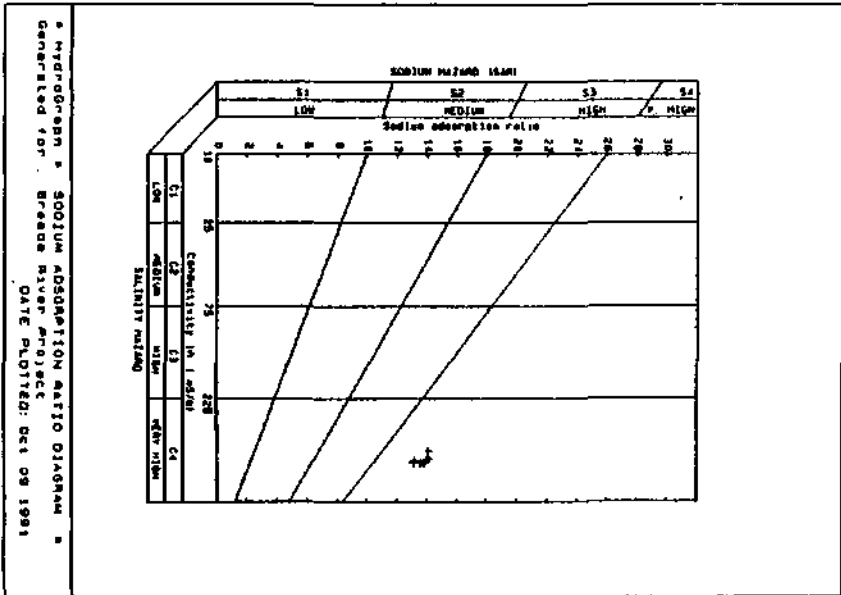

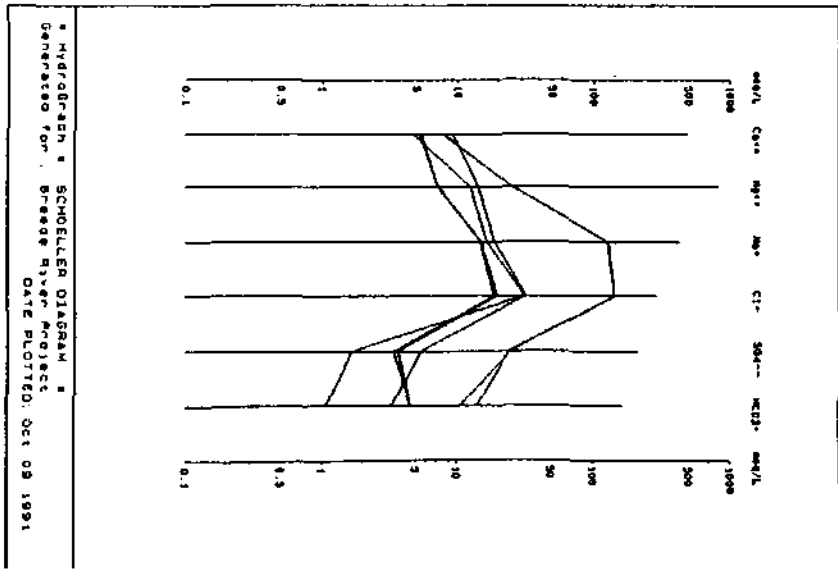
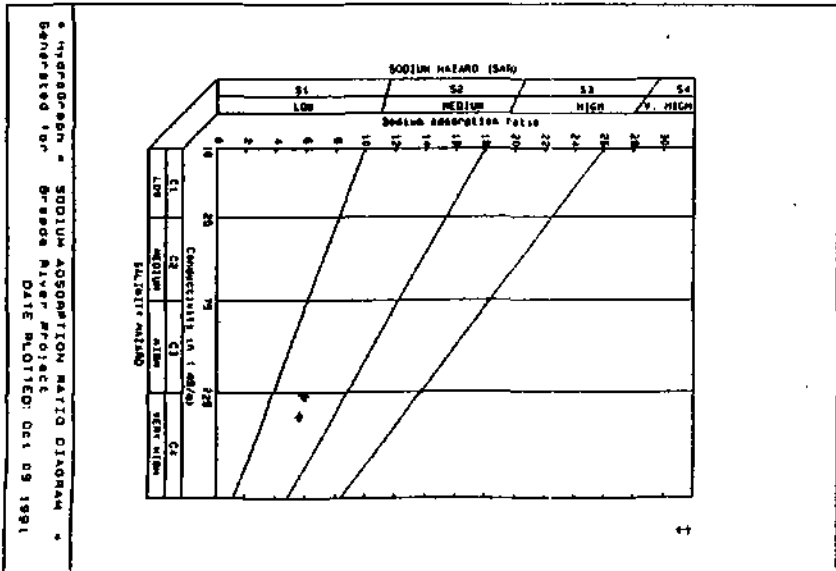
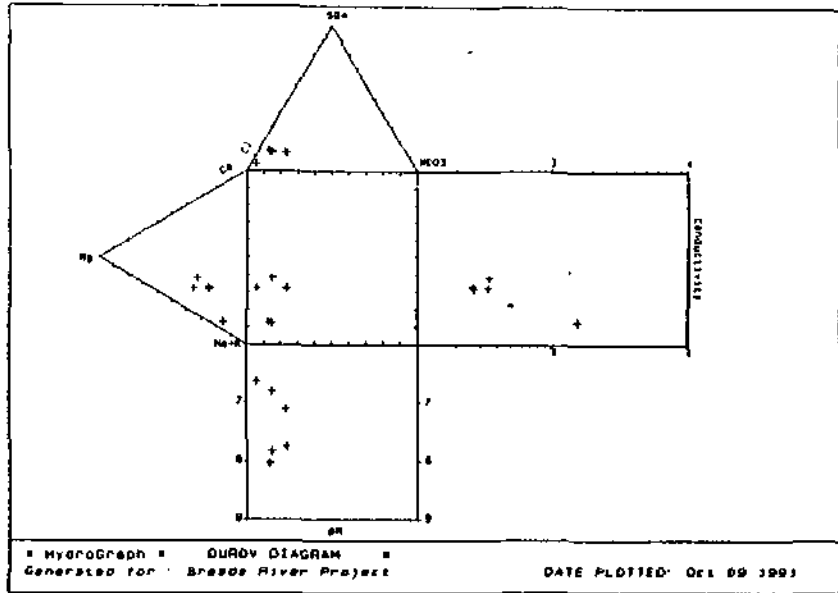
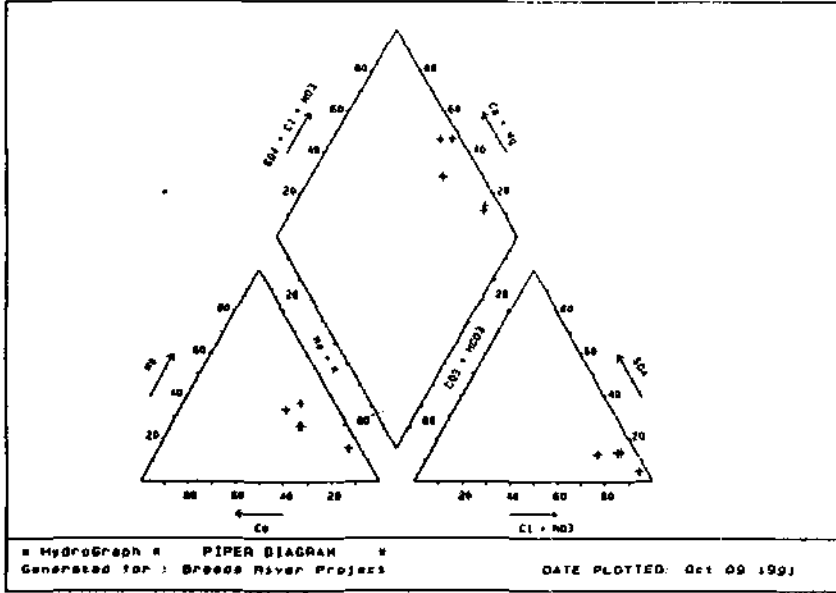

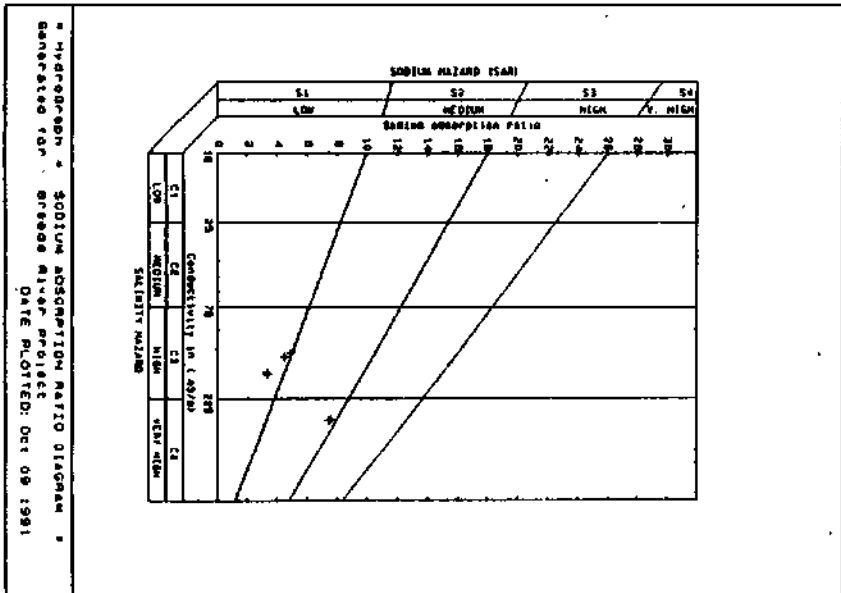
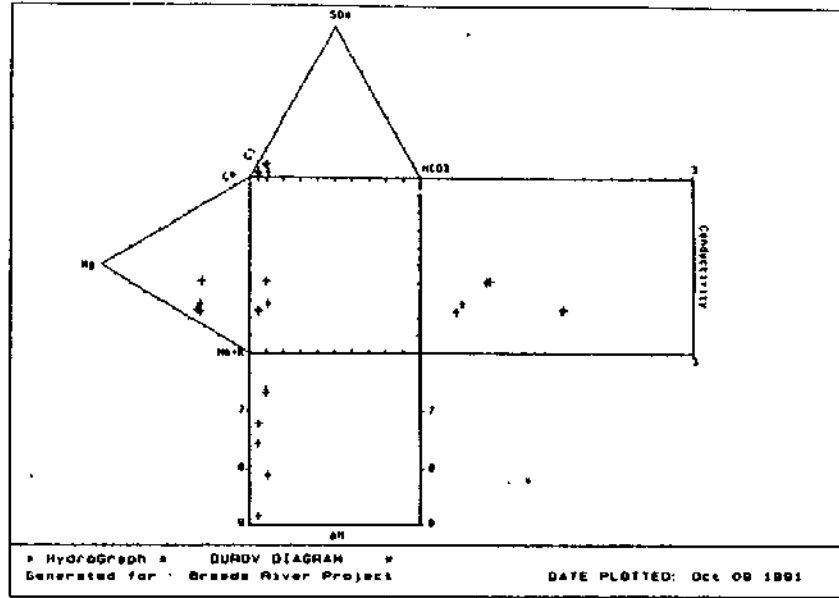
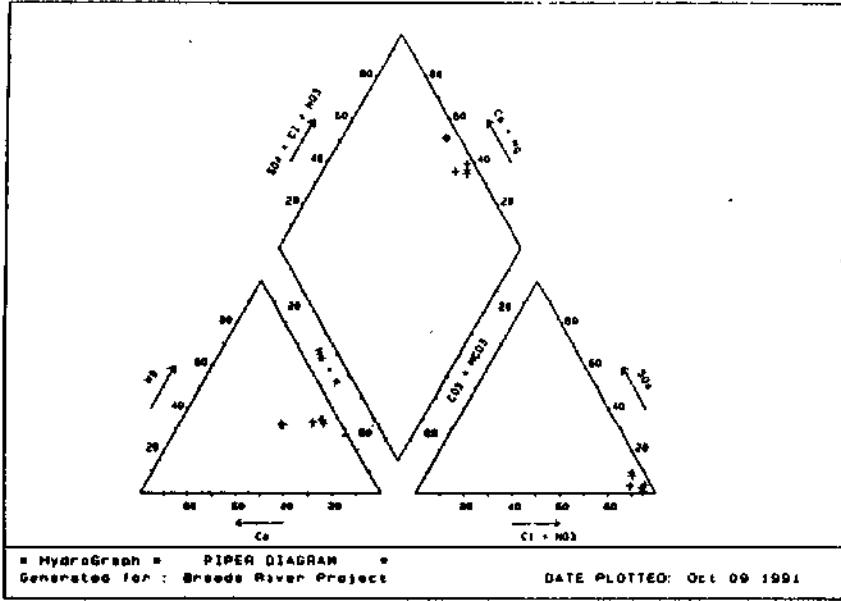

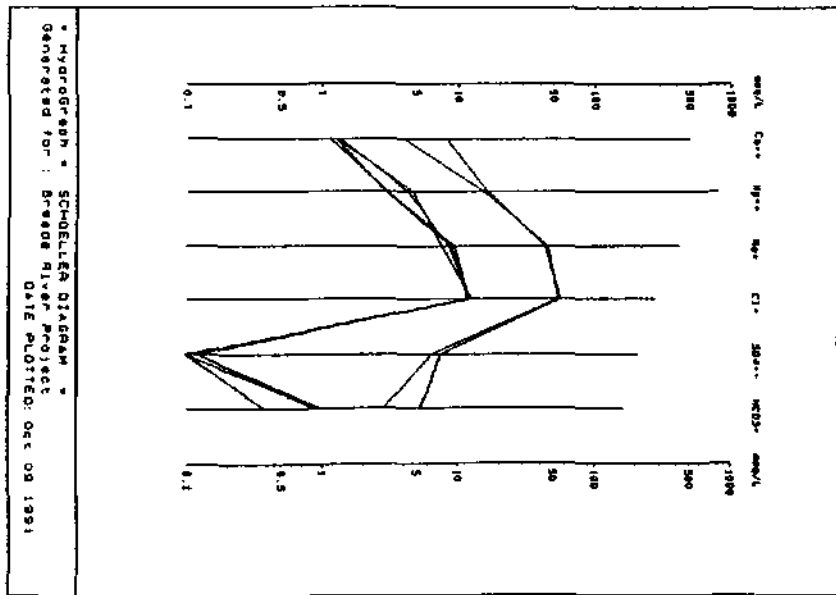
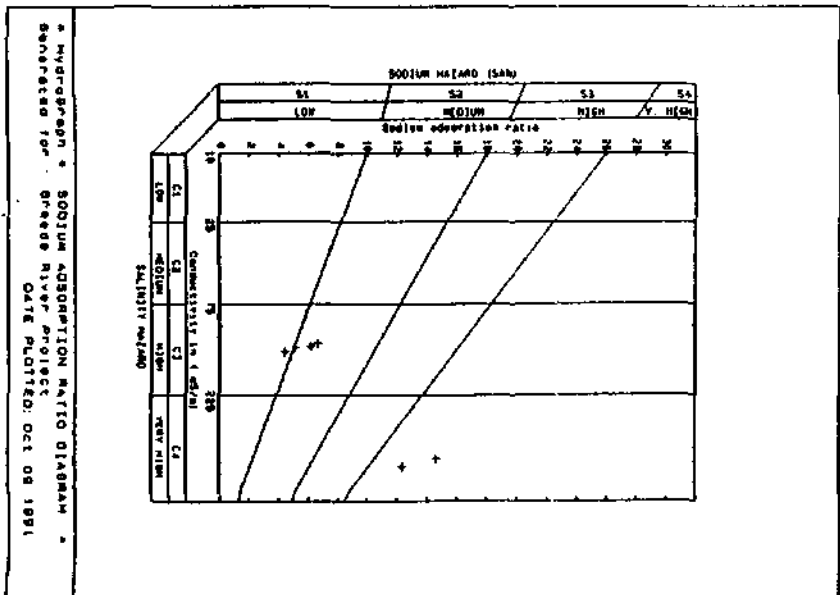
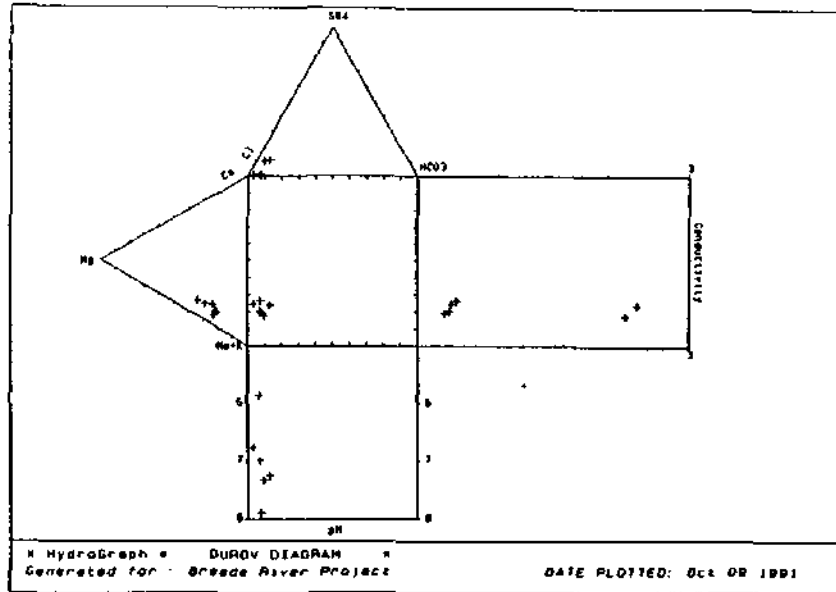
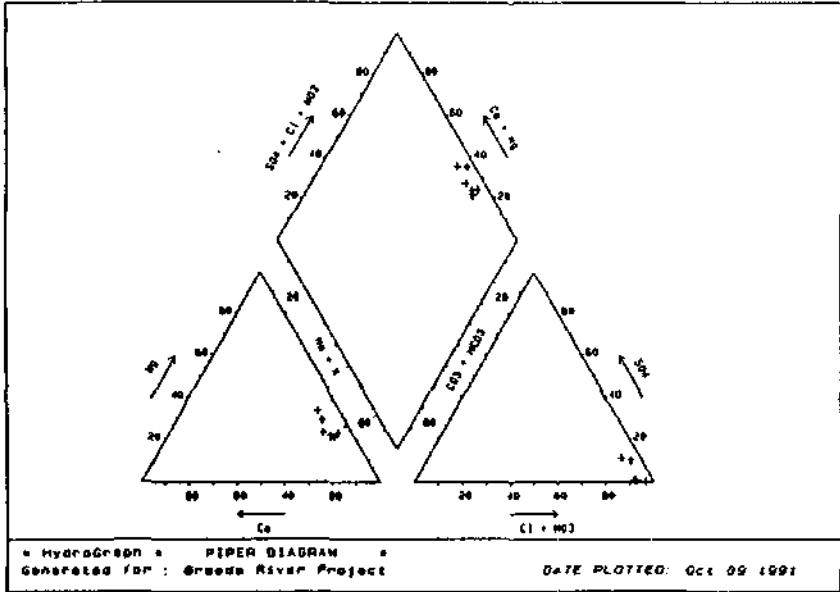

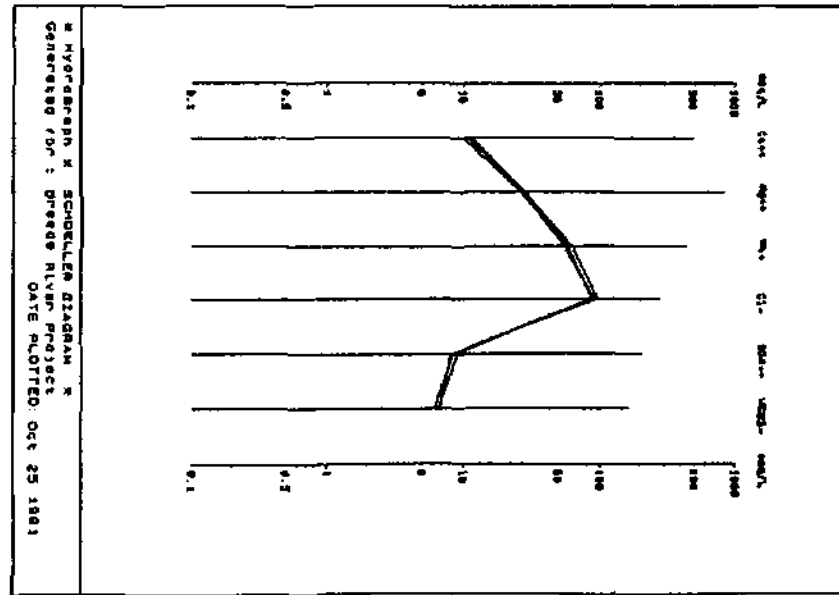
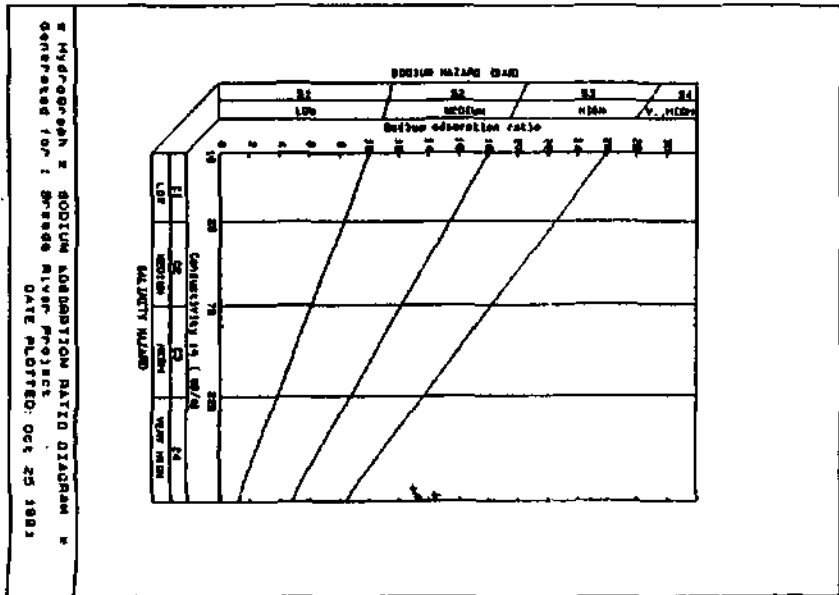
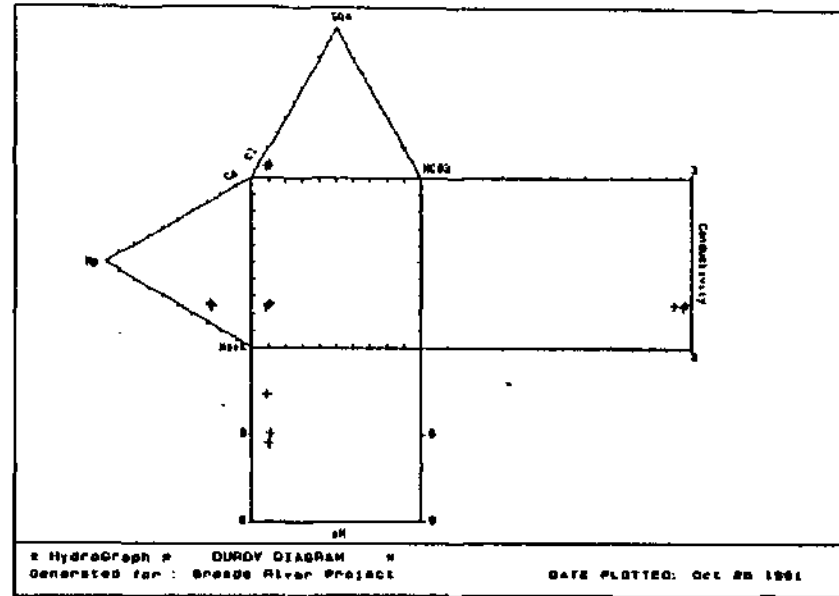
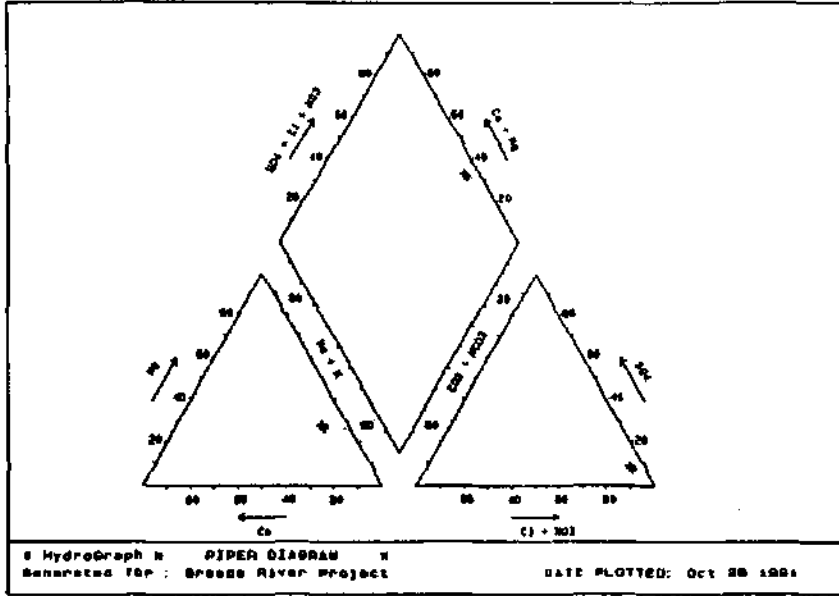

Bokkeveld 3319DD02576

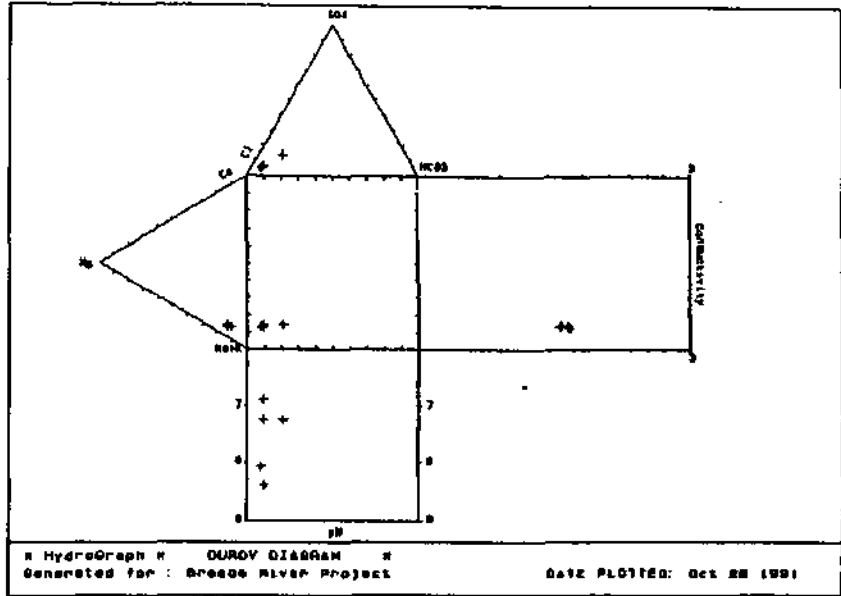
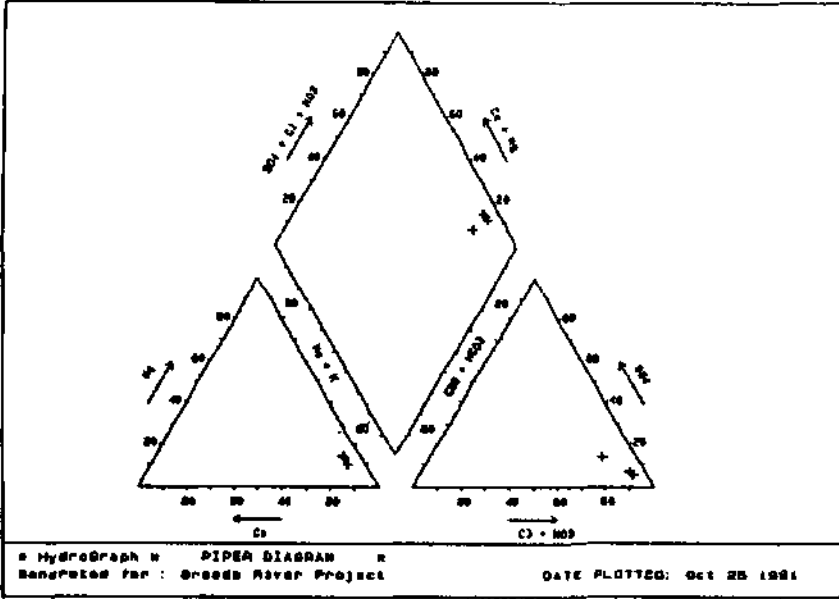

278

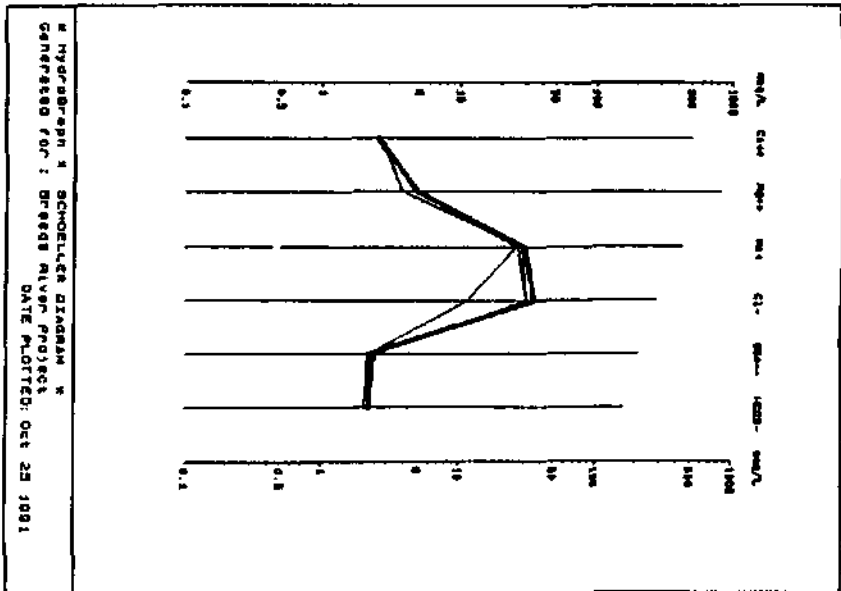
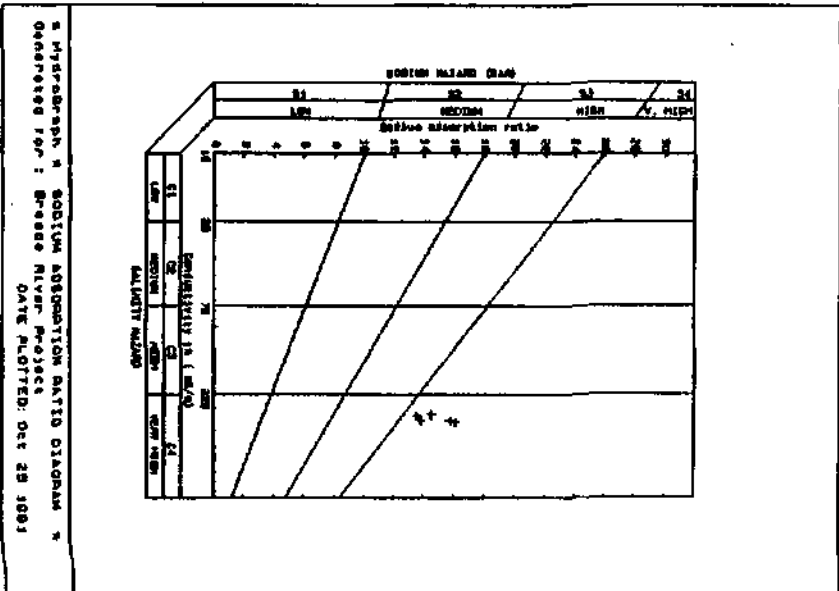

Bokkeveld 3319DD02584

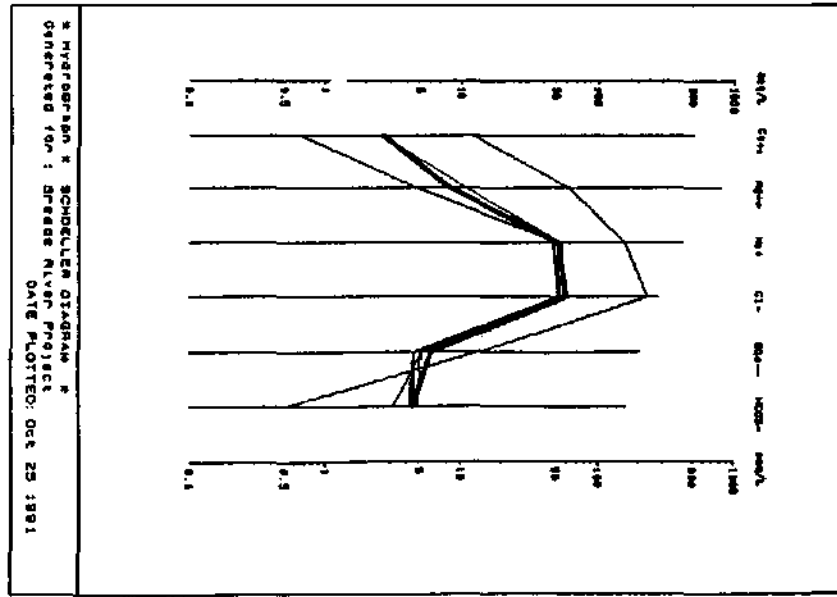
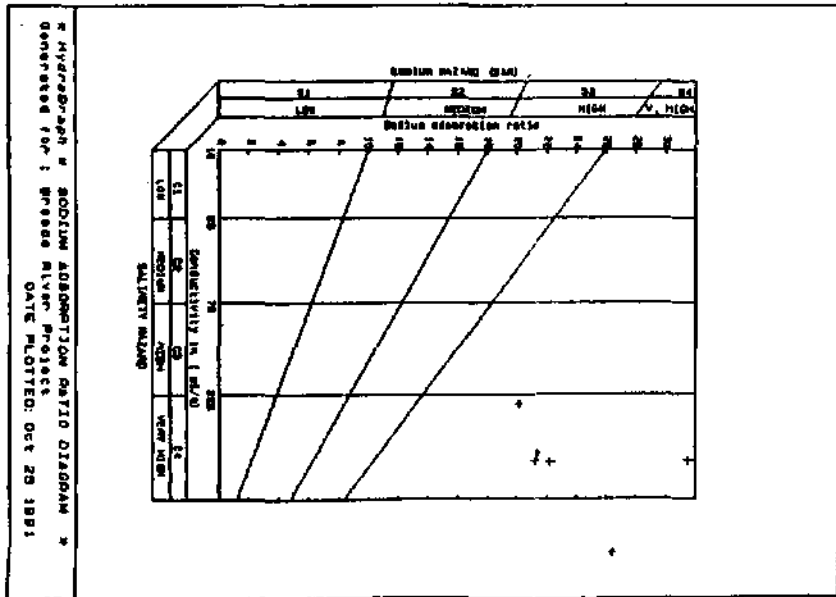
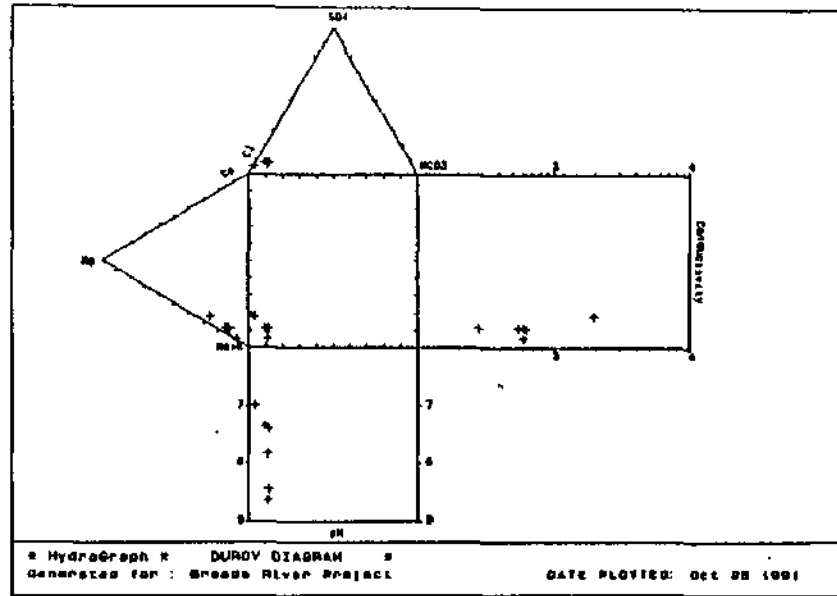
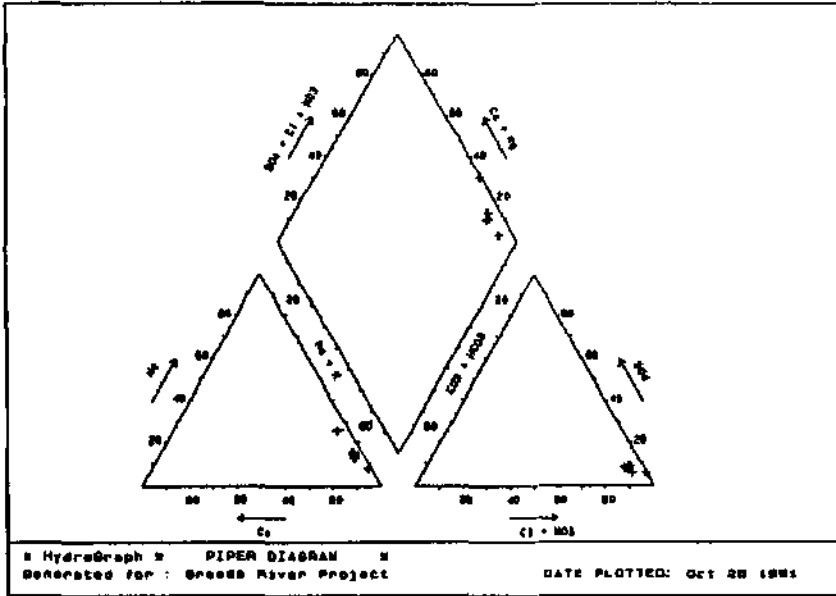

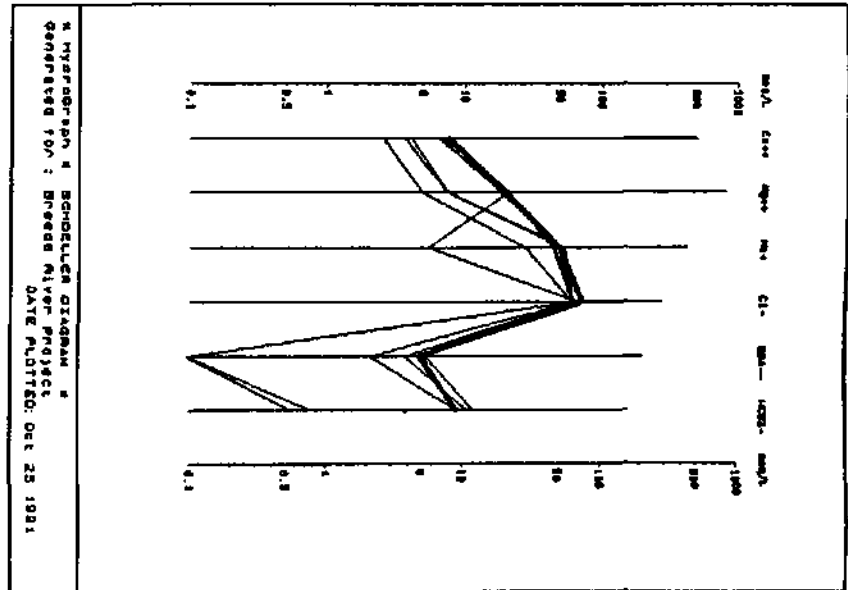
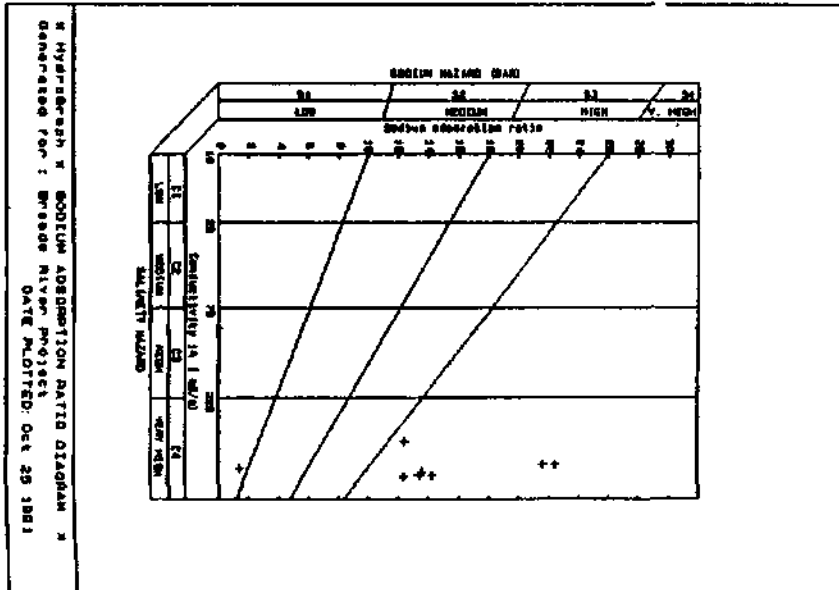
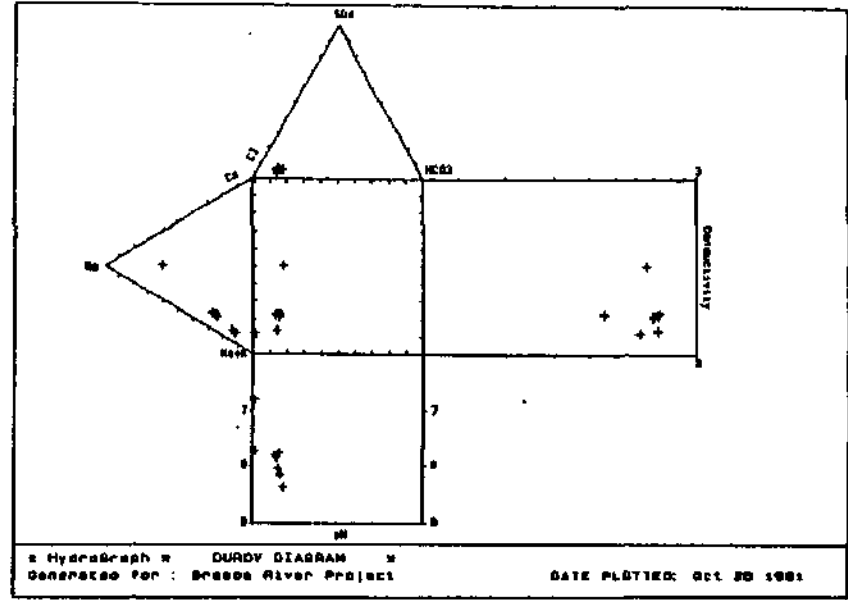
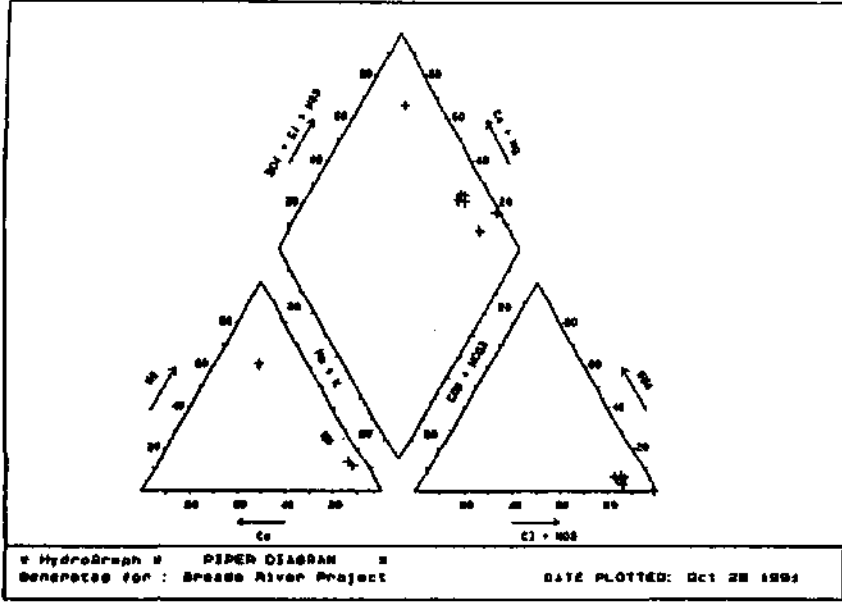

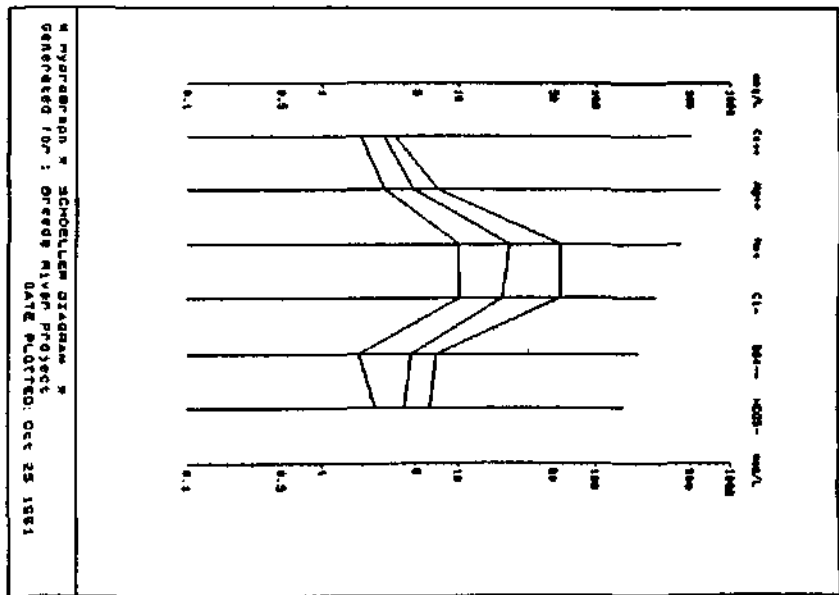
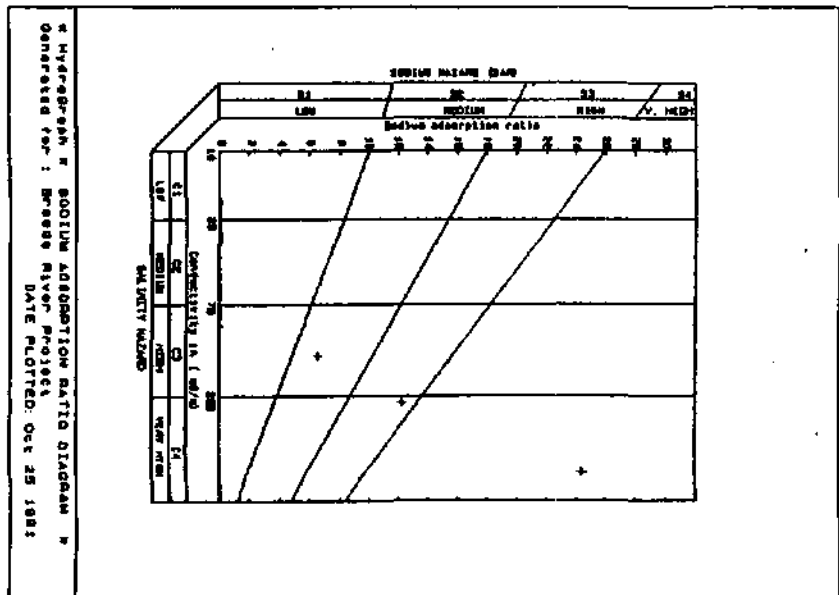
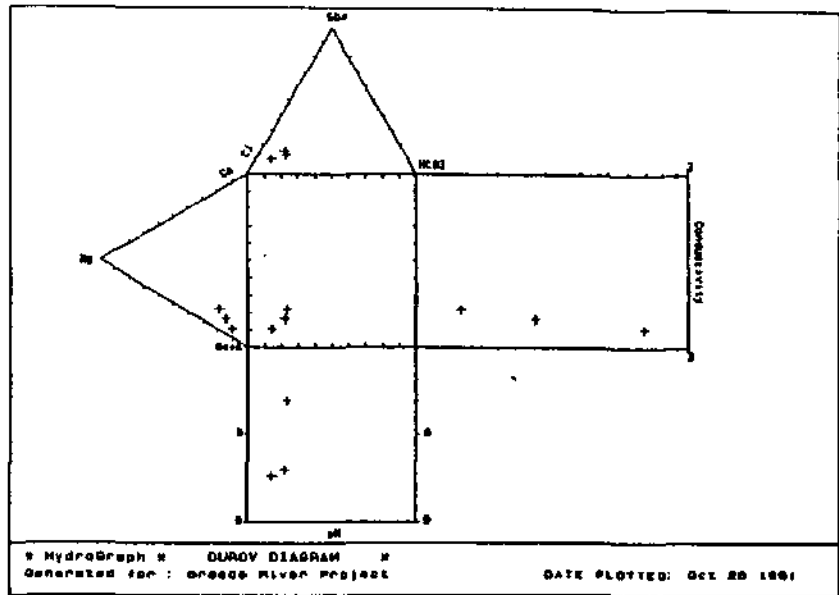
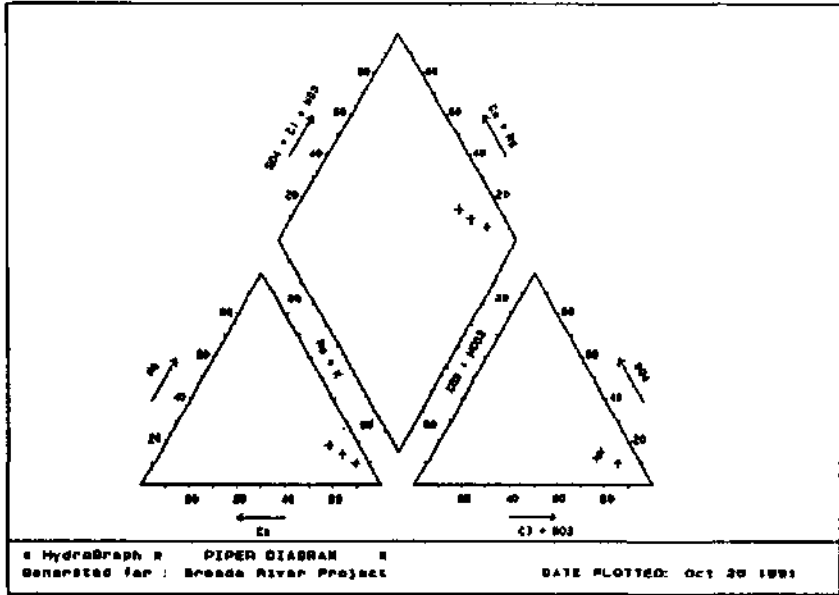

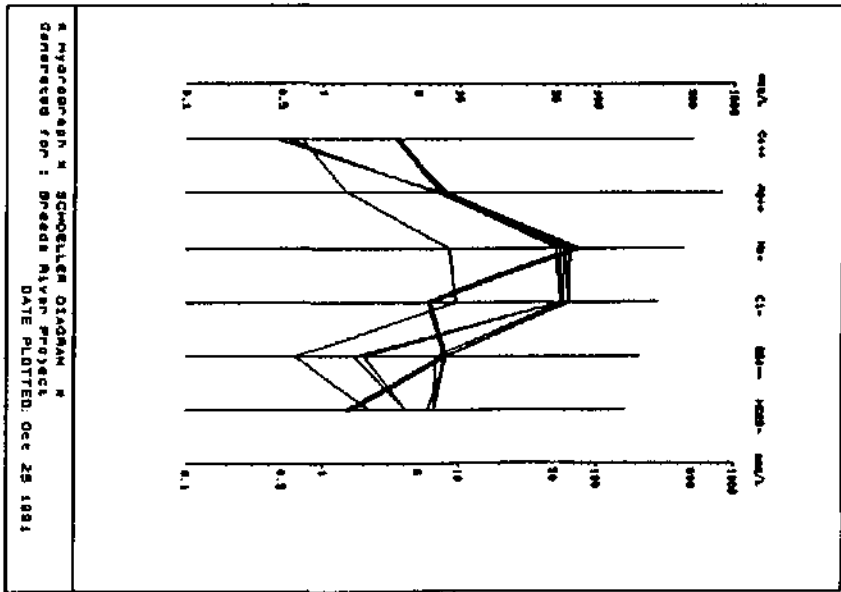
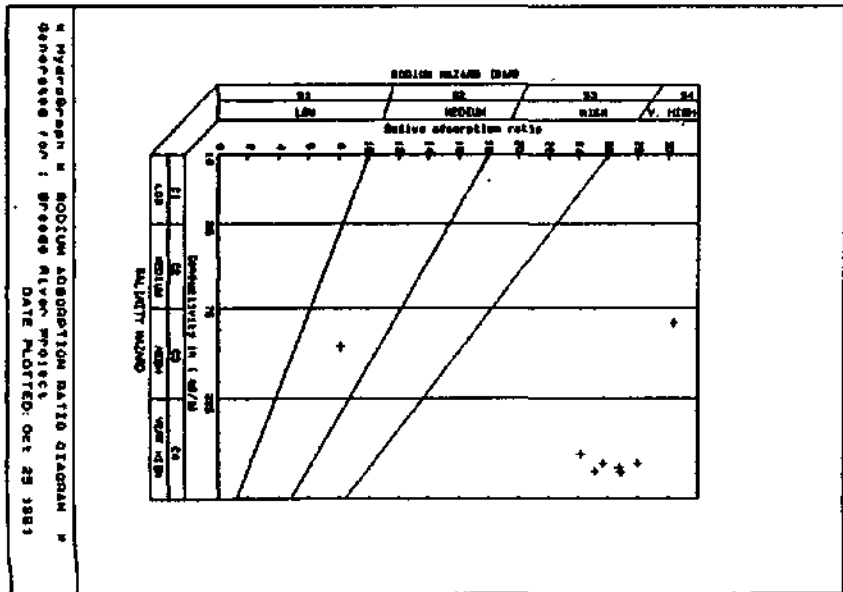
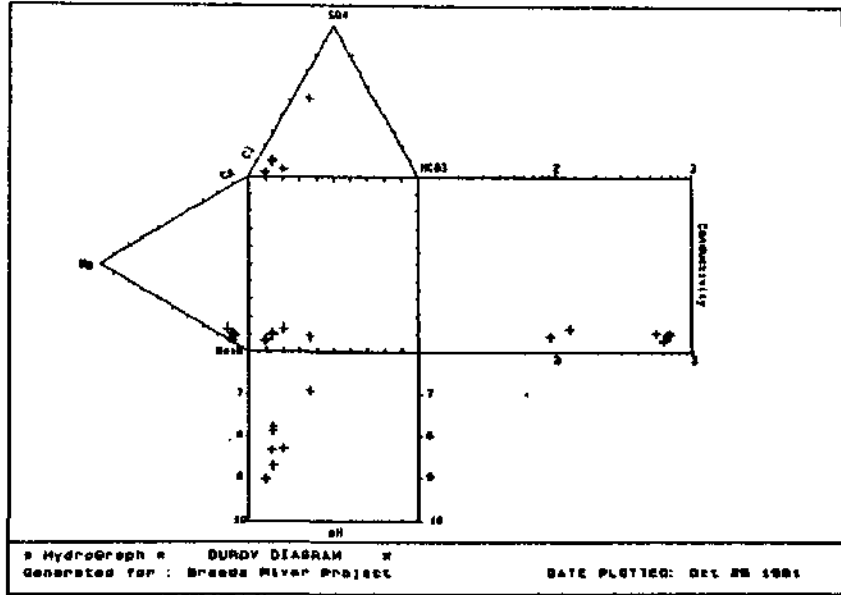
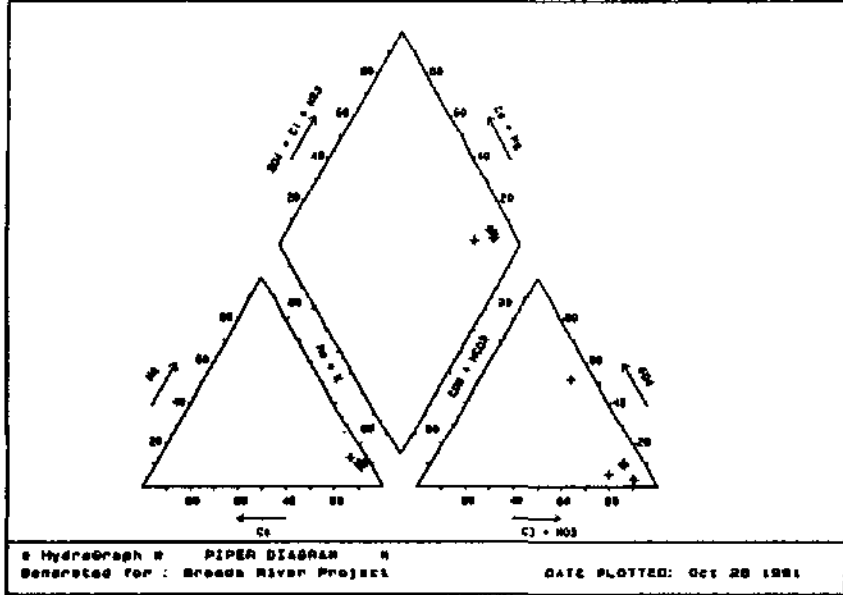

Appendix 10

Hydrochemical graphs:
Witteberg Group

 * HydroBase * User Defined Report * Date printed : 18 January 1992
 Generated for : Braeds River Project
 Date range : 19000101 to 19991231

 Data from file BASICINF :

SITE_ID_NR	NR_ON_MAP	SITE_NAME	SITE_TYPE	DEPTH
3319CD00026	JF01	JASONKLOOP	Borehole	80.00
3319CD00027	JF02	JASONKLOOP	Borehole	80.00
3319DD00111	Z	DE HEX RIVIER, ca 50 m NW road junction	Dug well	0.00
3319DD00112	AA	DE HEX RIVIER, opposite well	Fountain	0.00

WITTEBERG

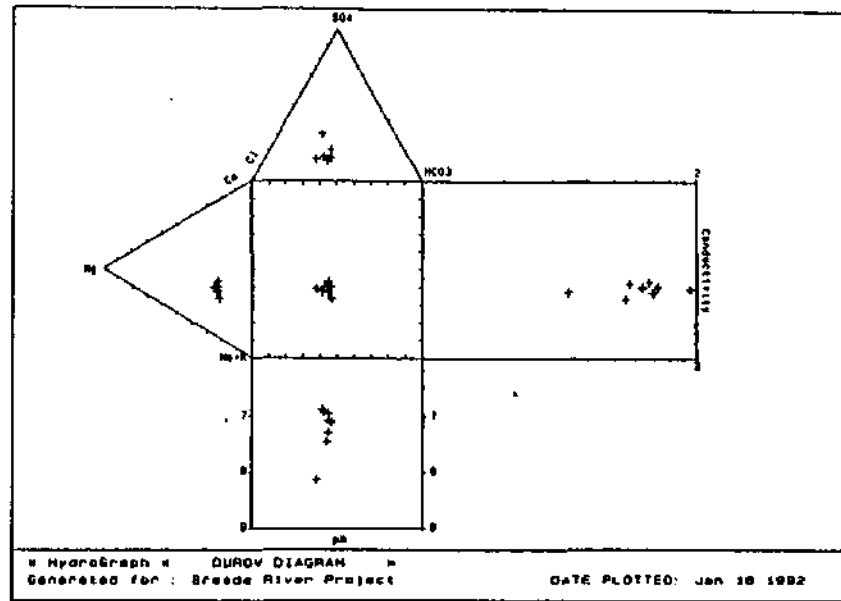
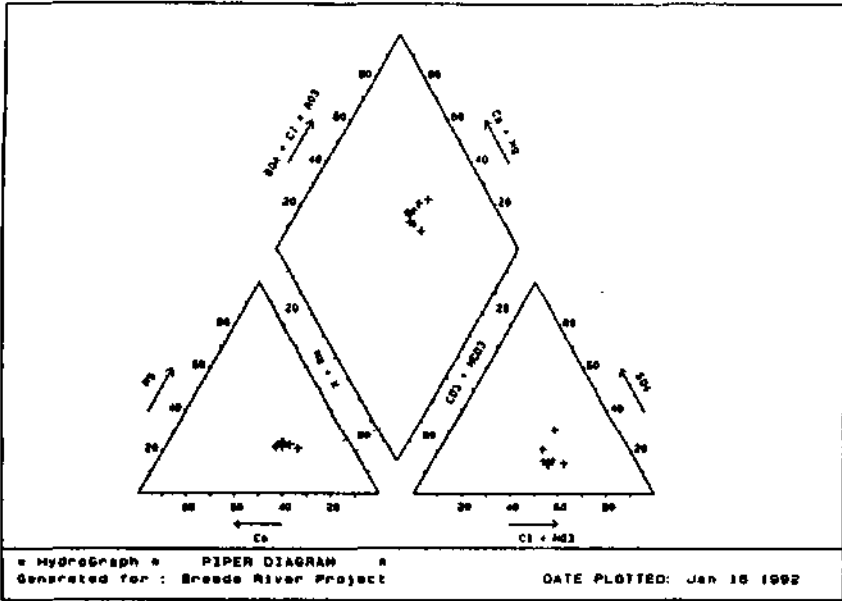

284

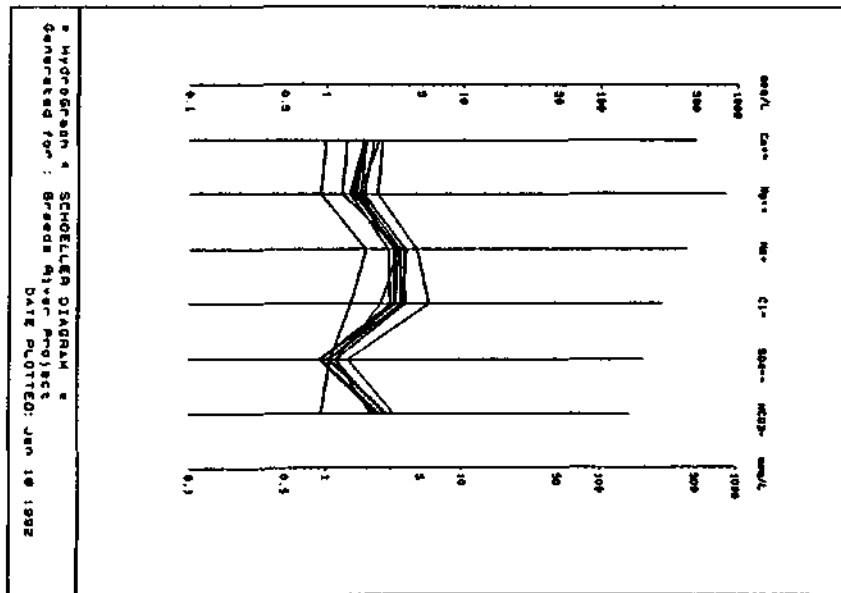
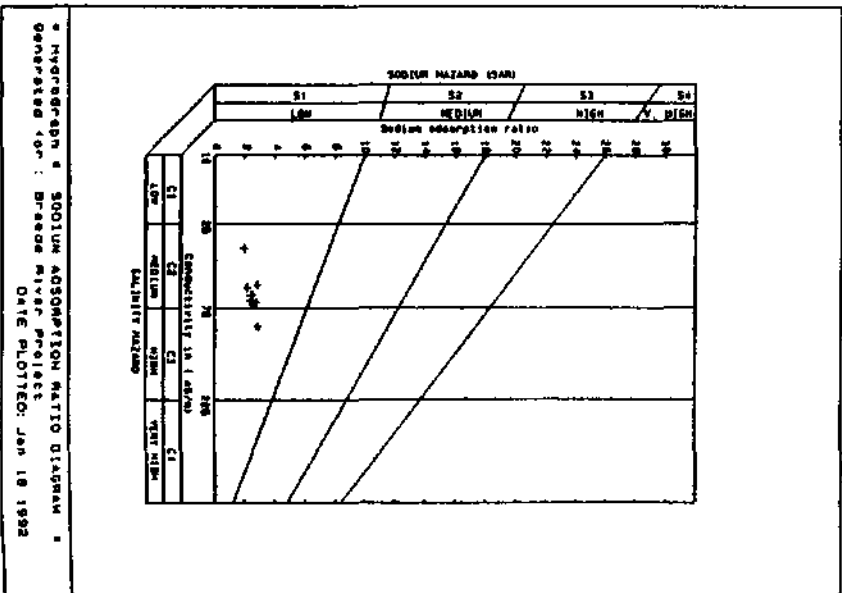

WITTEBERG

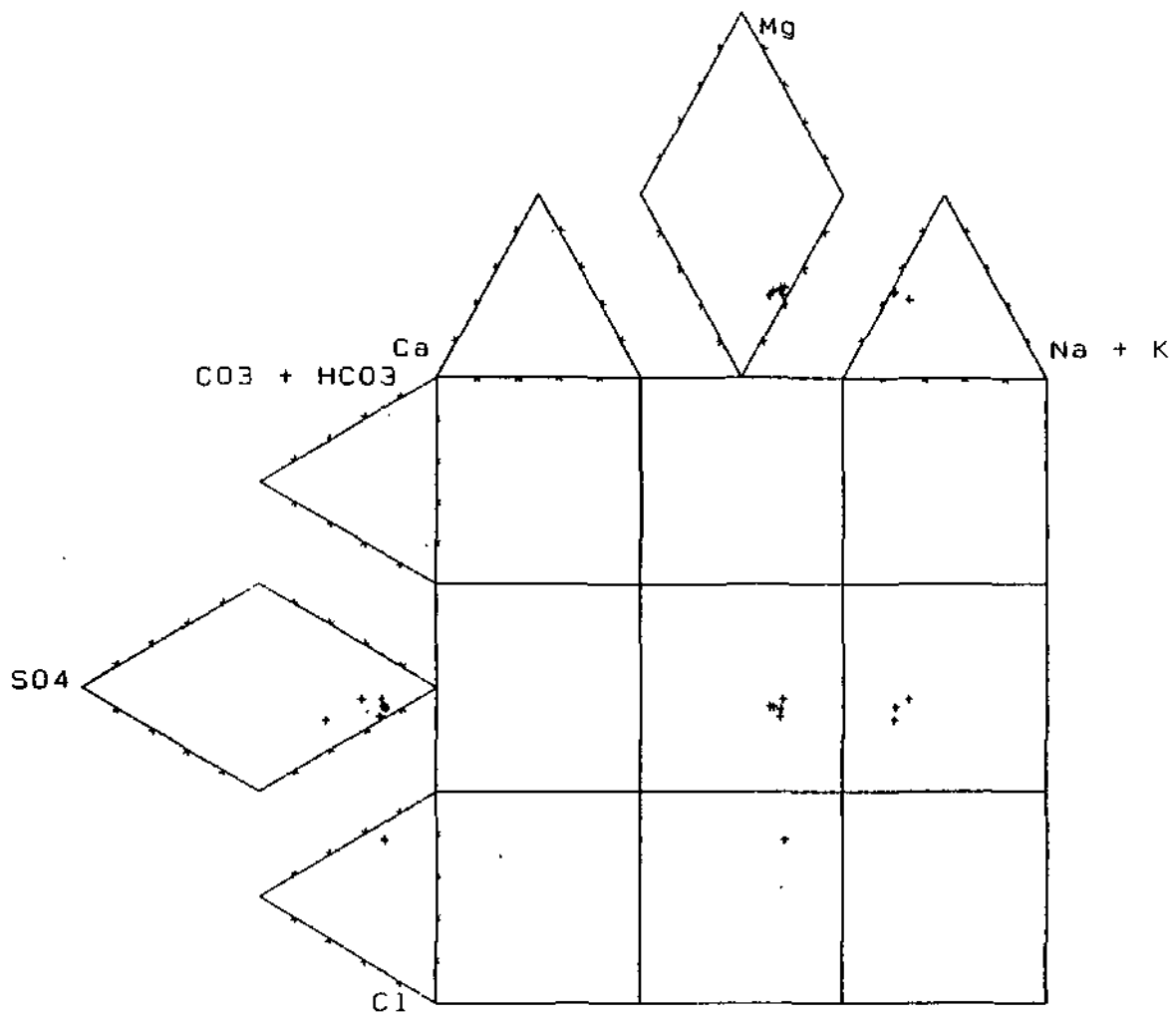

* HydroBase * EXPANDED DUROV DIAGRAM *
Generated for : Breede River Project

DATE PLOTTED: Jan 18 1992

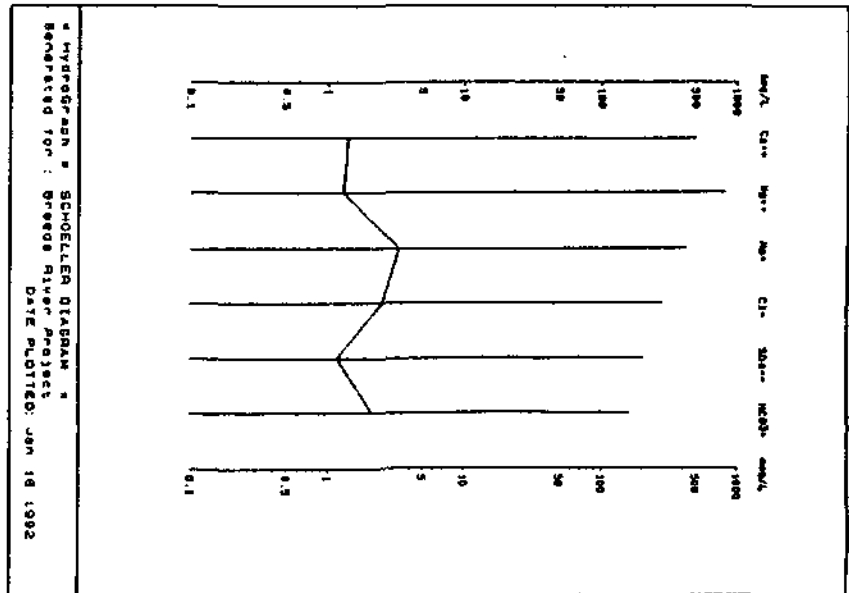
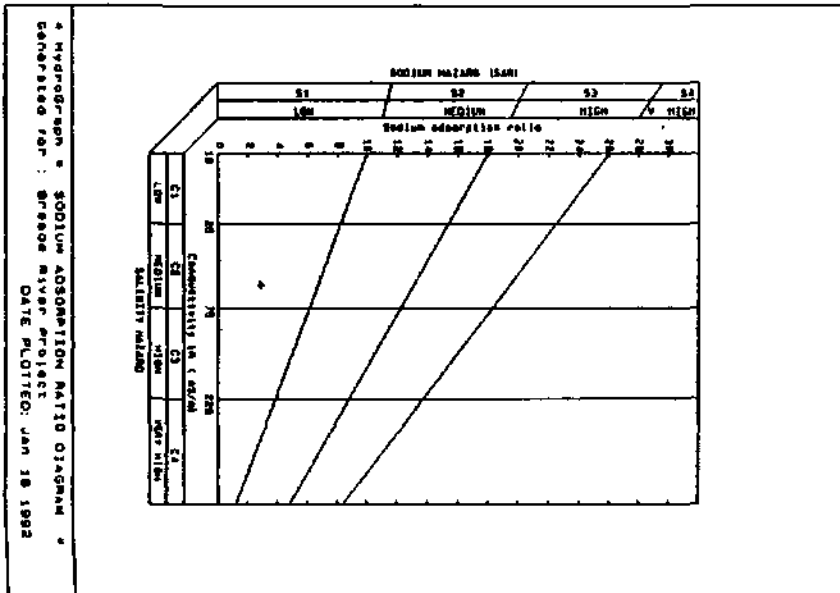
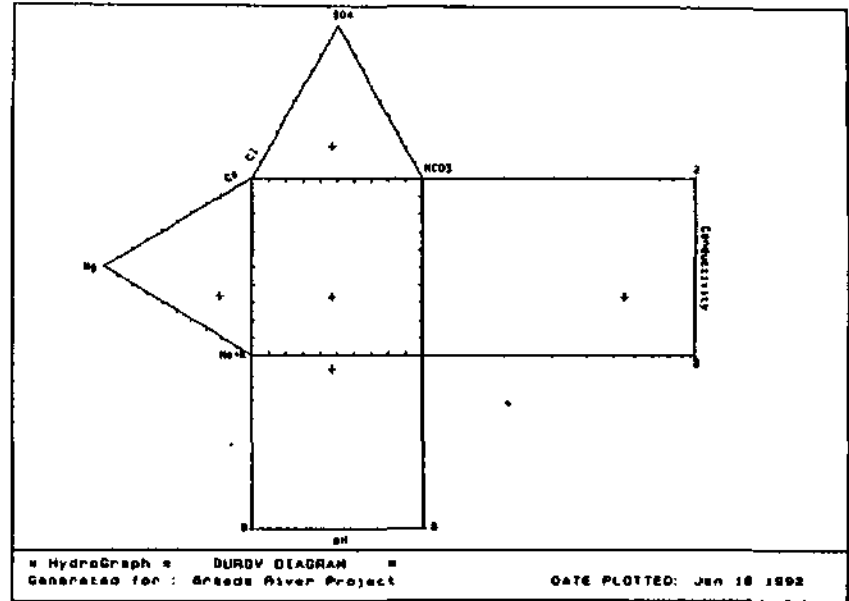
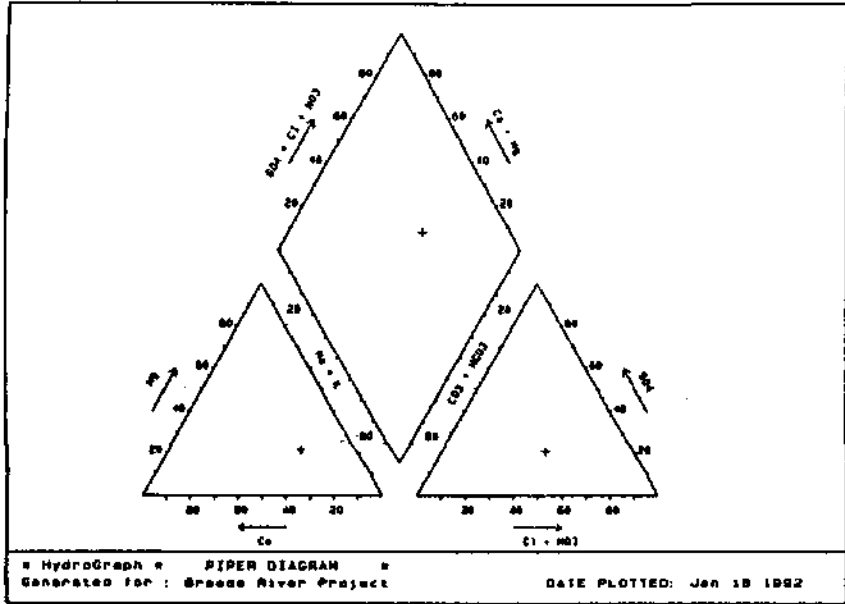

WITTEBERG : 3319CD00027

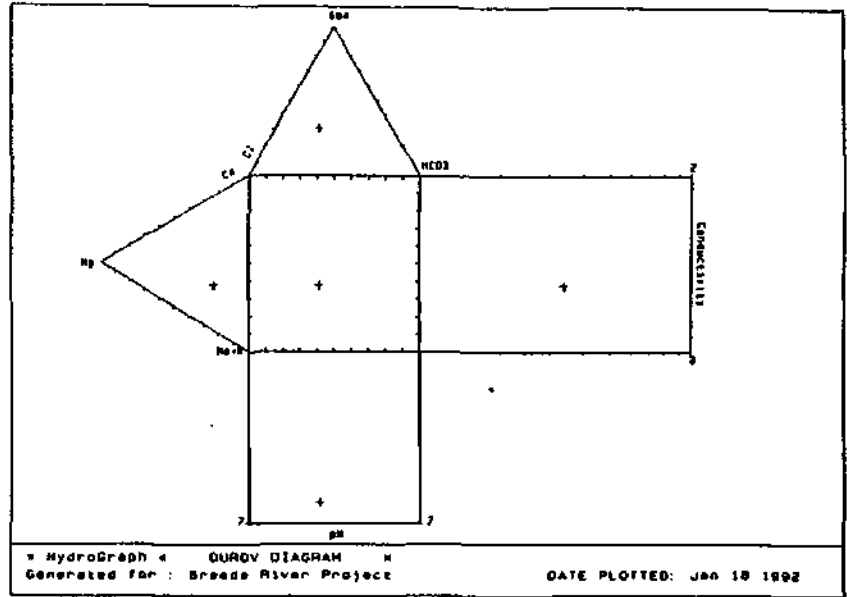
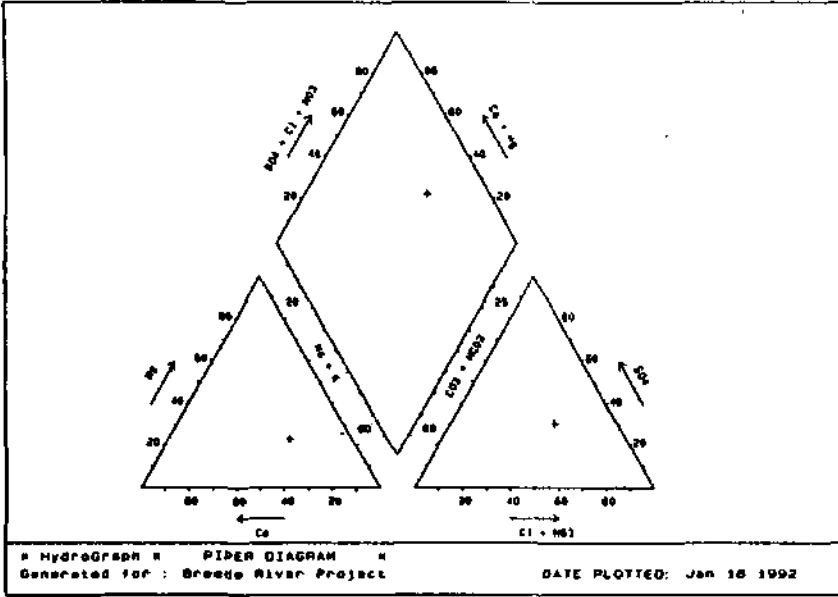

287

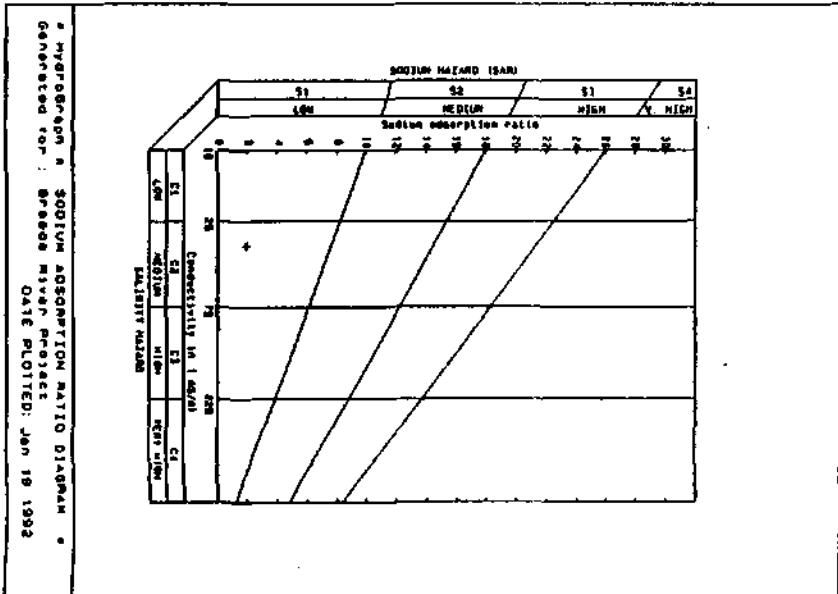

WITTEBERG : 3319DD00111

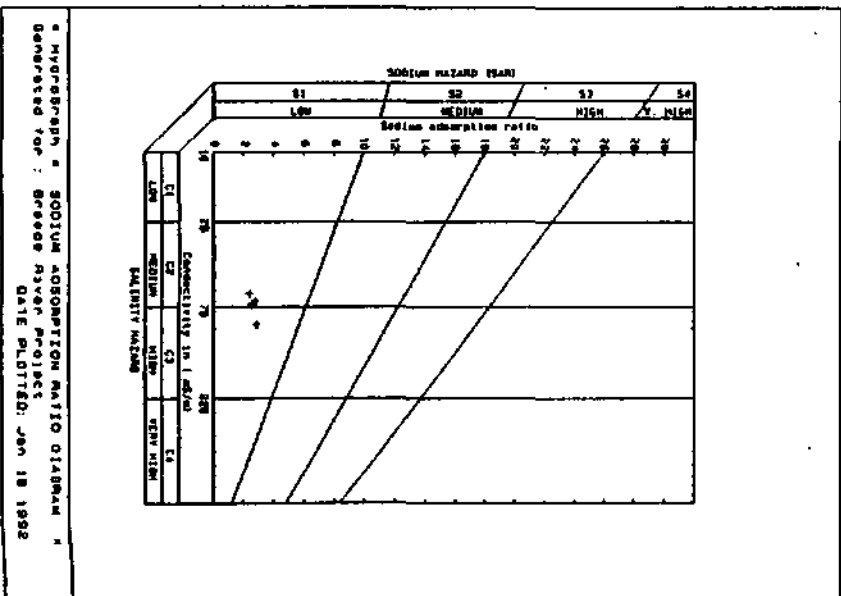
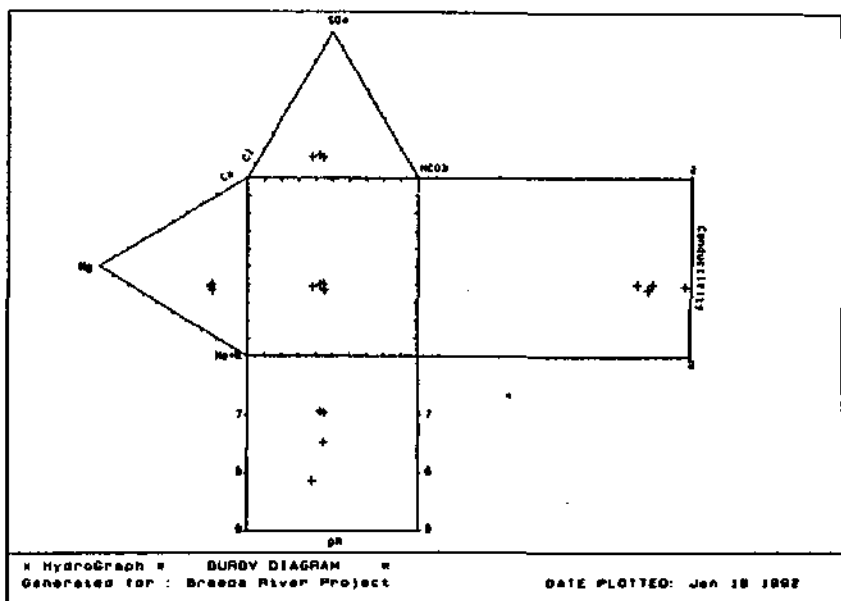
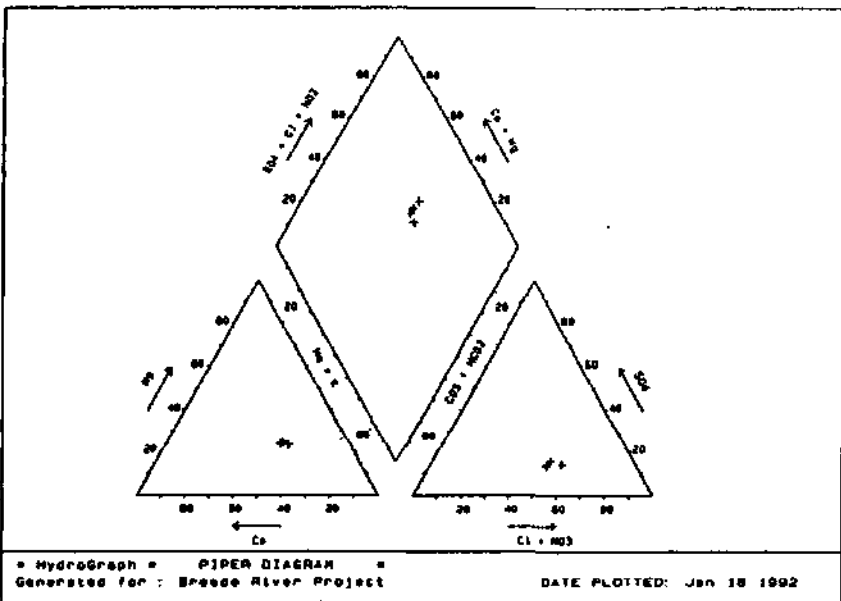

WITTEBERG : 3319DD00112

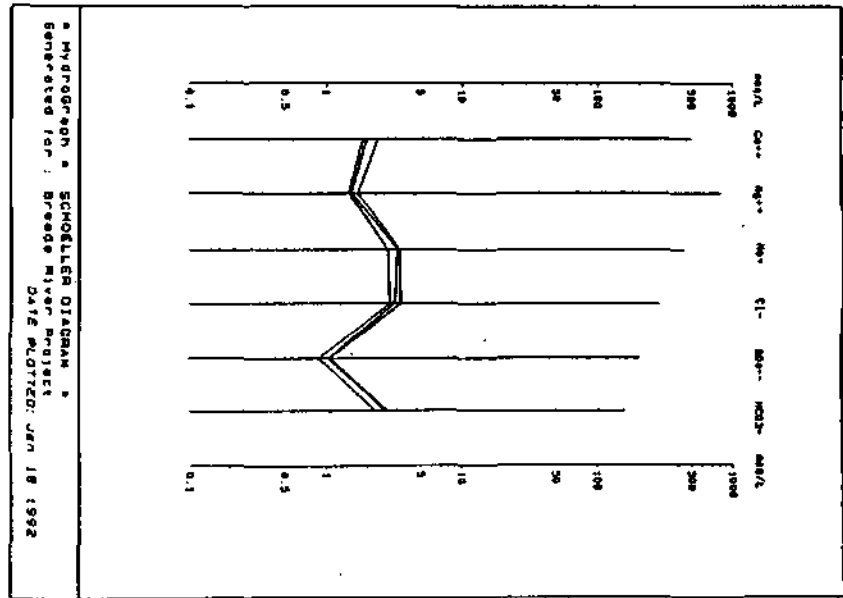
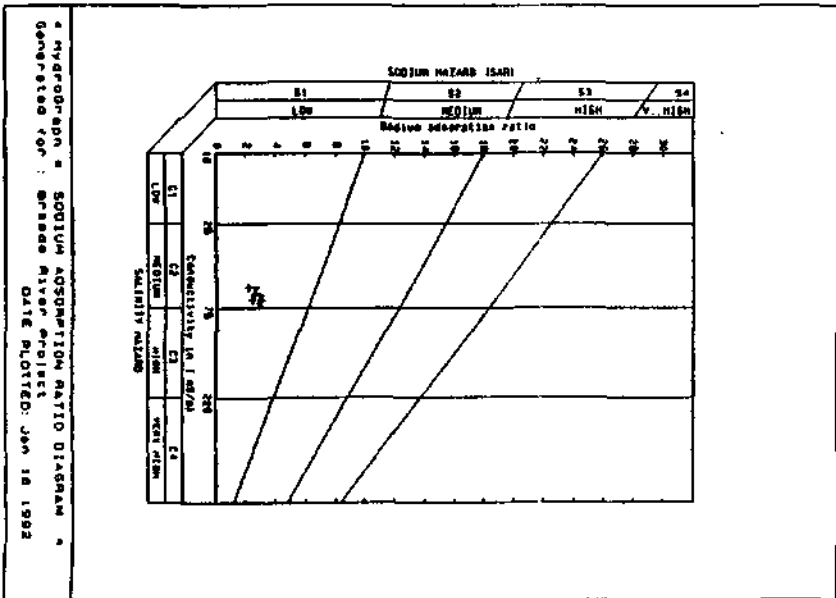
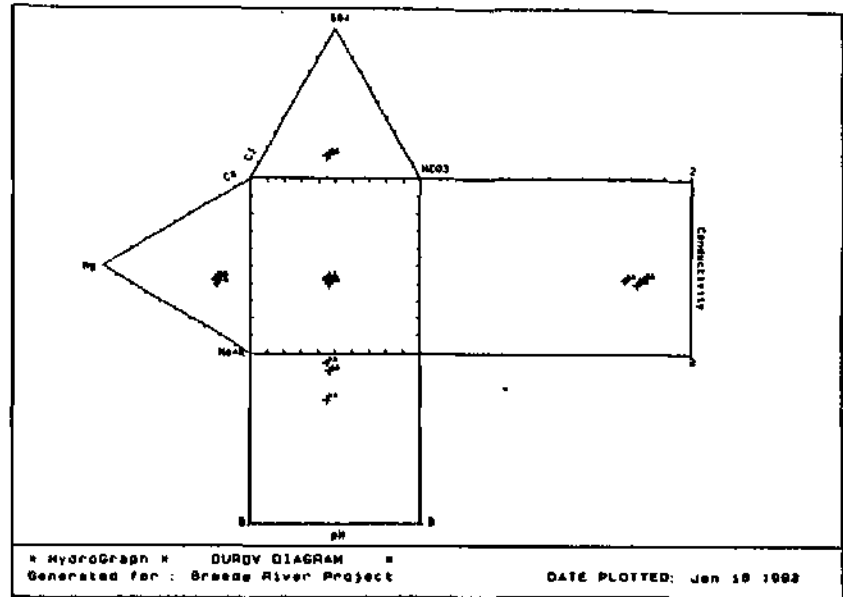
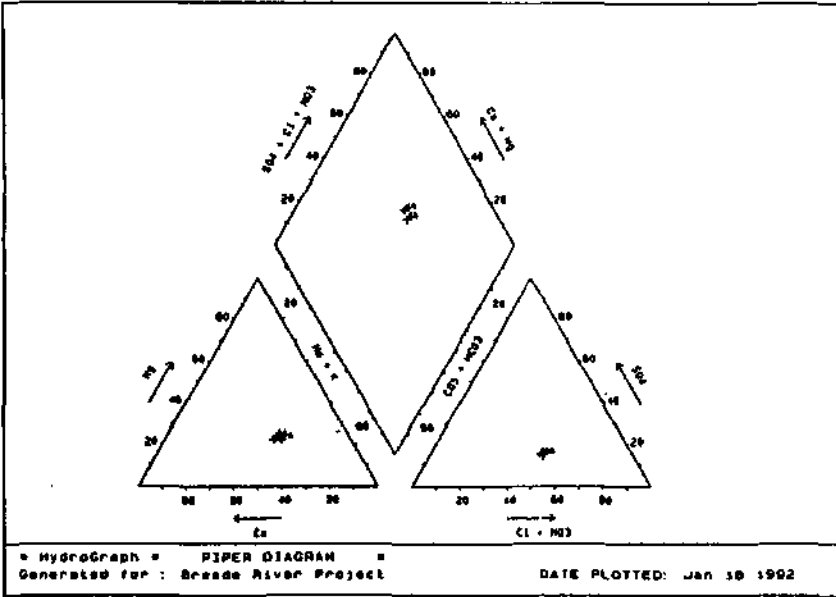

Appendix 11

Hydrochemical graphs:
Enon Formation

 * HydroBase * User Defined Report * Date printed : 18 January 1992
 Generated for : Breede River Project
 Date range : 19000101 to 19991231

 Data from file BASICINF :

SITE_ID_NR	NR_ON_MAP	SITE_NAME	SITE_TYPE	DEPTH
3319DD00002	G33571	OVER HET ROODEZAND 112	Borehole	80.00
3319DD00003	G33571A	OVER HET ROODEZAND 112	Borehole	80.00
3319DD00004	G33572	GOEDE MOED 128	Borehole	80.00
3319DD00007	G33575	GOEDE MOED 128	Borehole	80.00
3319DD00013	G33581	OVER HET ROODEZAND 112	Borehole	80.00
3319DD00014	G33582	OVER HET ROODEZAND 112	Borehole	80.00
3319DD00015	G33583	OVER HET ROODEZAND 112	Borehole	80.00
3319DD00017	G33585	RIET VALLEI 115	Borehole	80.00
3319DD00018	G33586	GOEDE MOED 128	Borehole	80.00
3319DD00019	G33587	BAKENSHOOGTE 114	Borehole	80.00
3319DD00035	KR01	KLAAS VOOGDS RIVIER - CONCORDIA	Borehole	61.00
3319DD01594	G33594		Borehole	33.00
3319DD01595	G33595		Borehole	80.00
3319DD02572	G33572A		Borehole	25.00
3319DD02575	G33575A		Borehole	18.00
3319DD02583	G33583A		Borehole	20.00
3319DD02585	G33585A		Borehole	0.00

ENON

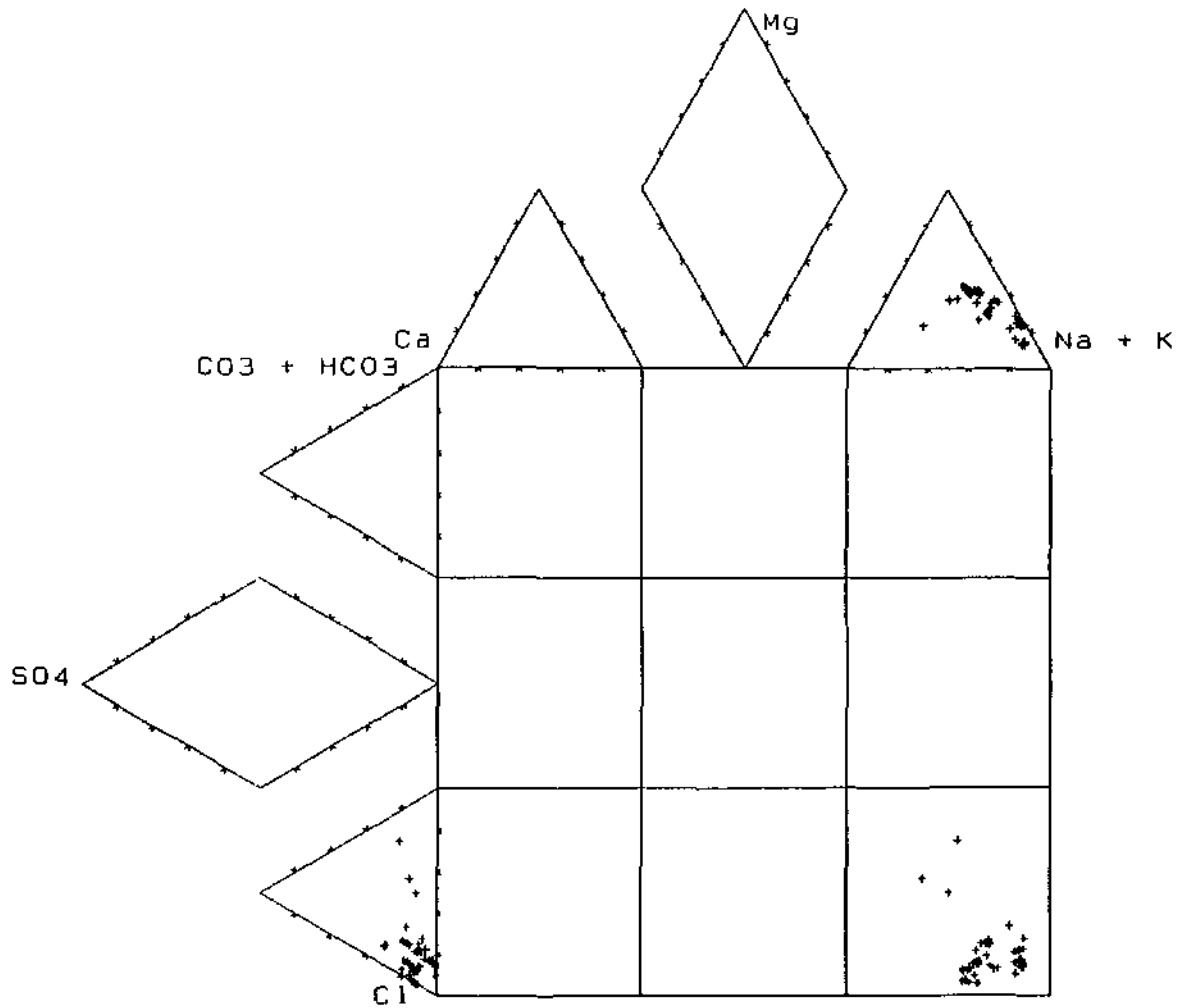

* HydroBase * EXPANDED DUROV DIAGRAM *
Generated for : Breede River Project

DATE PLOTTED: Jan 18 1992

ENON : 3319DD02585

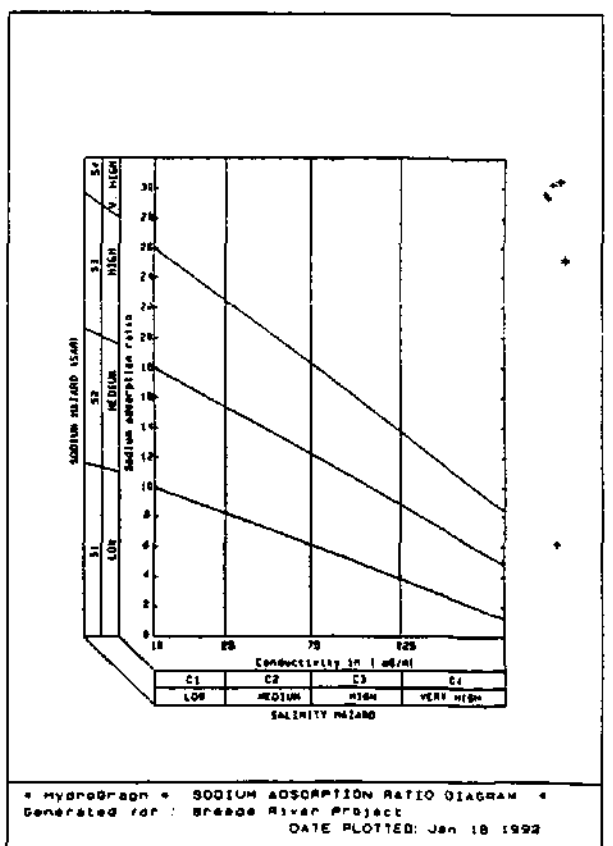
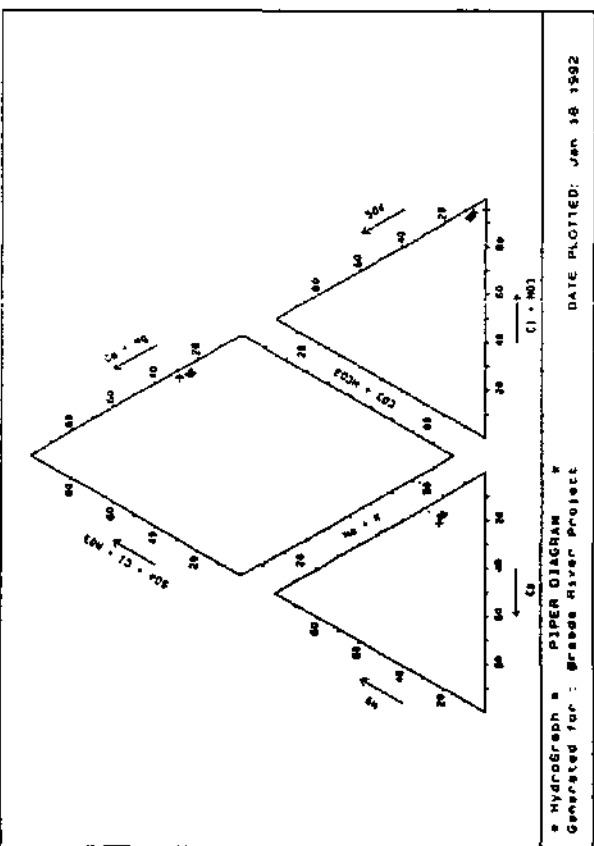
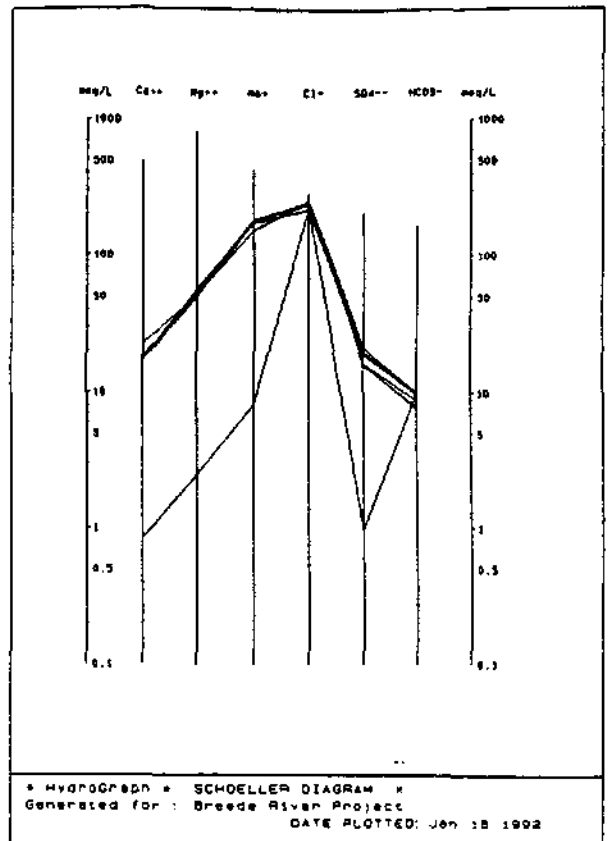
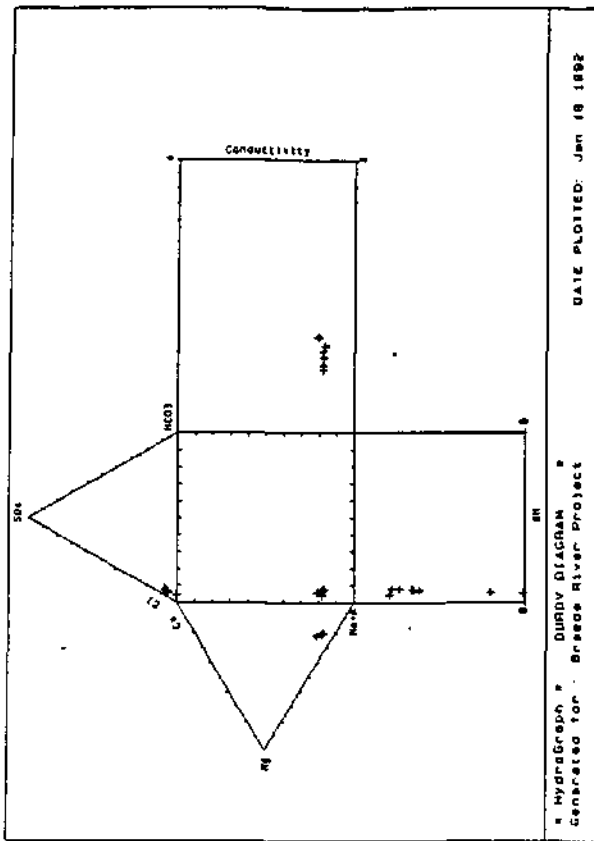

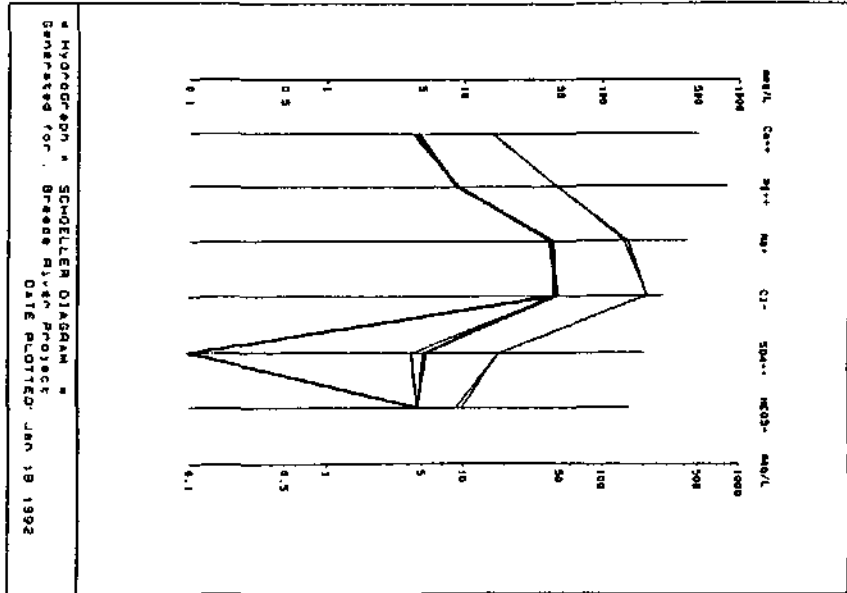
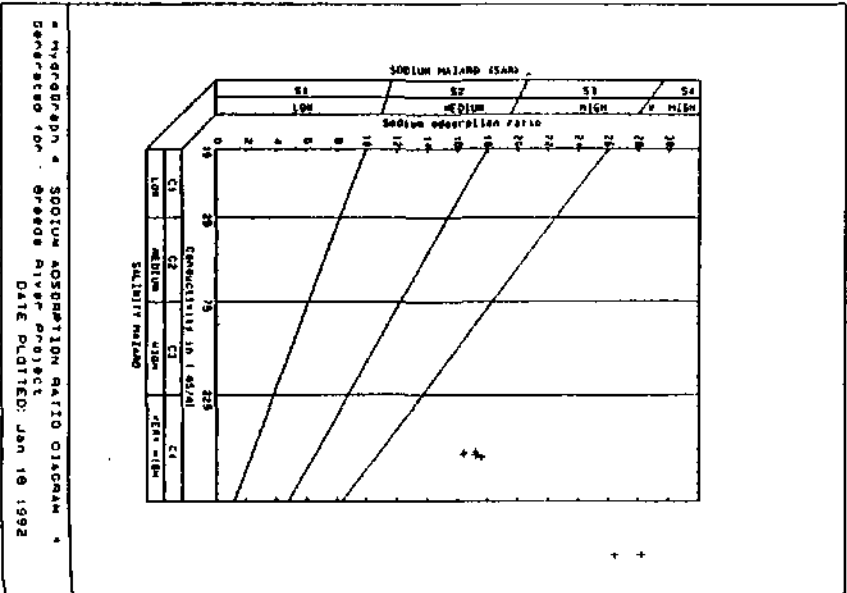
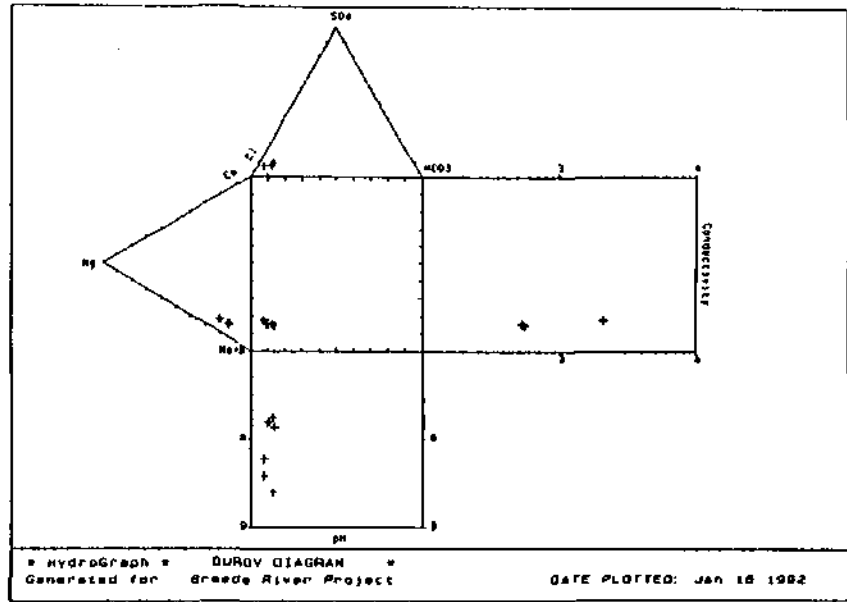
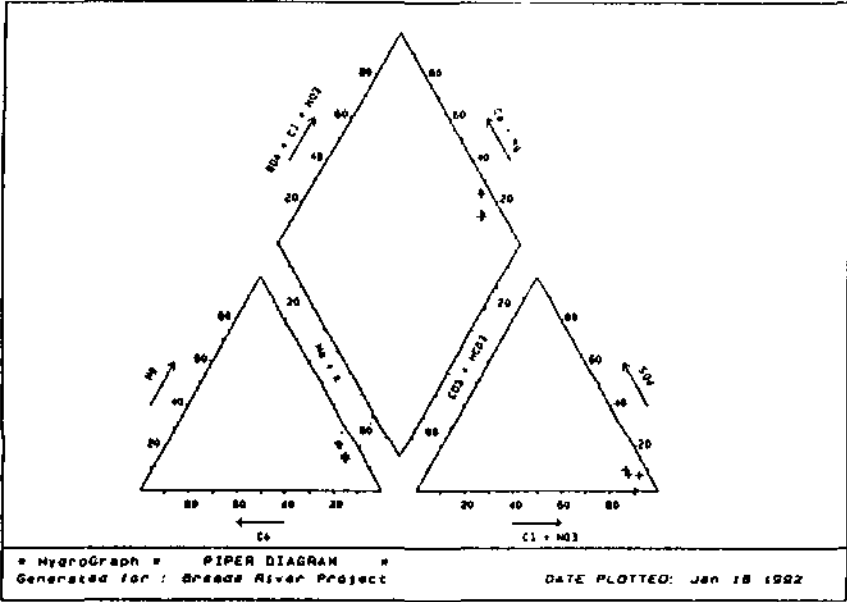

ENON : 3319DD02575

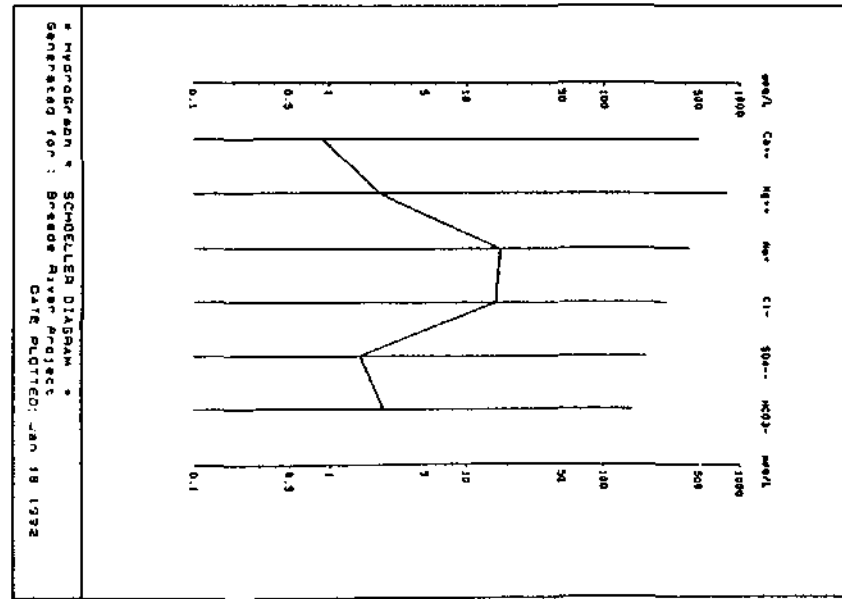
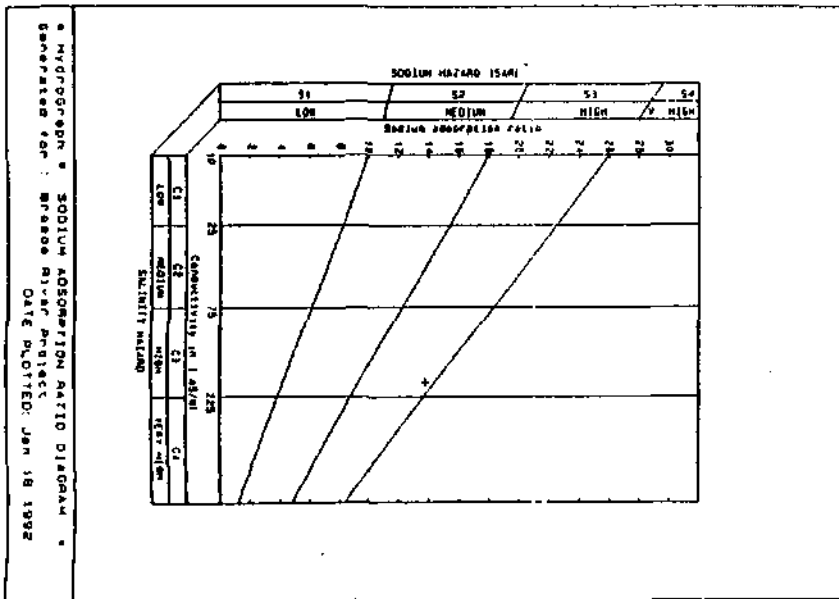
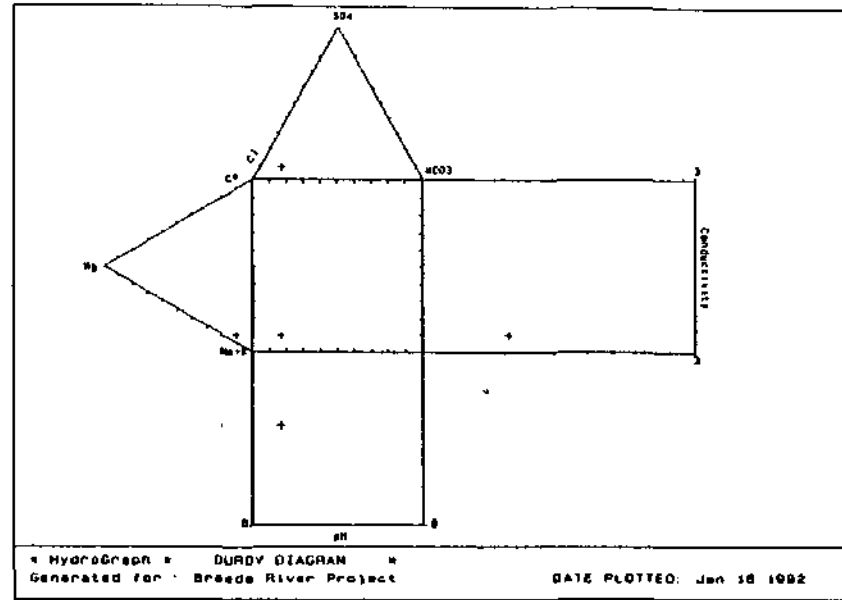
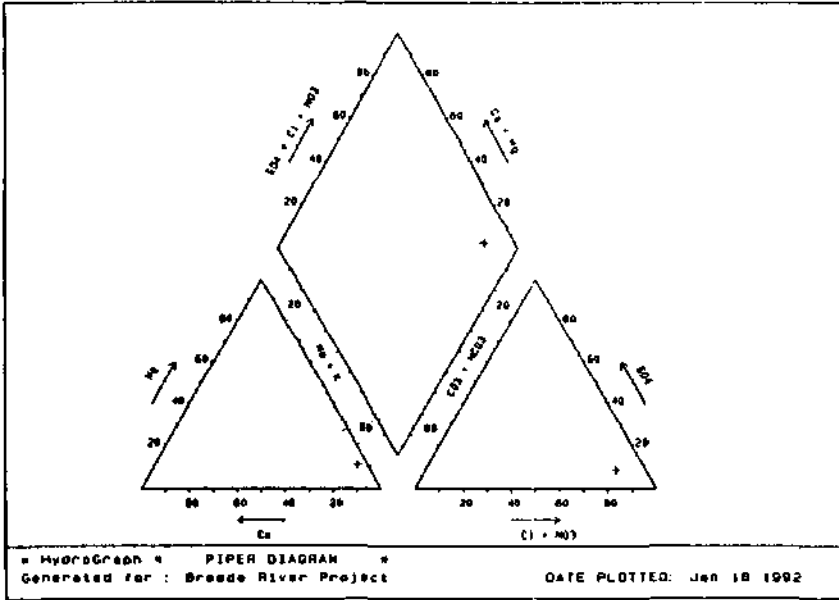

ENON : KR01

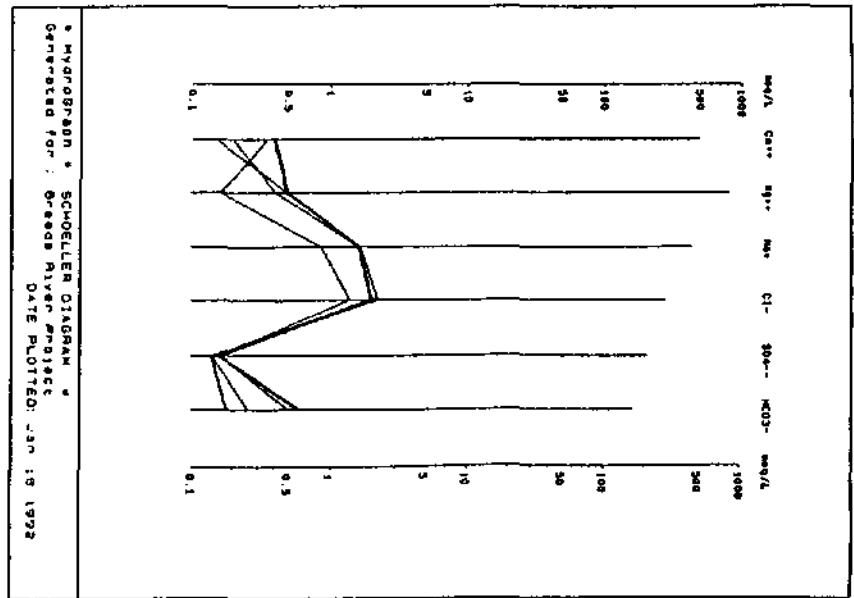
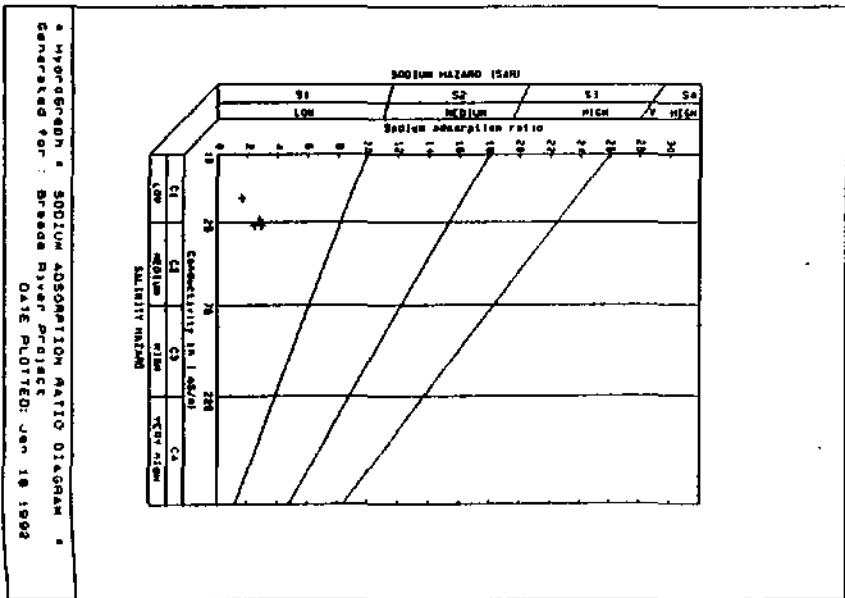
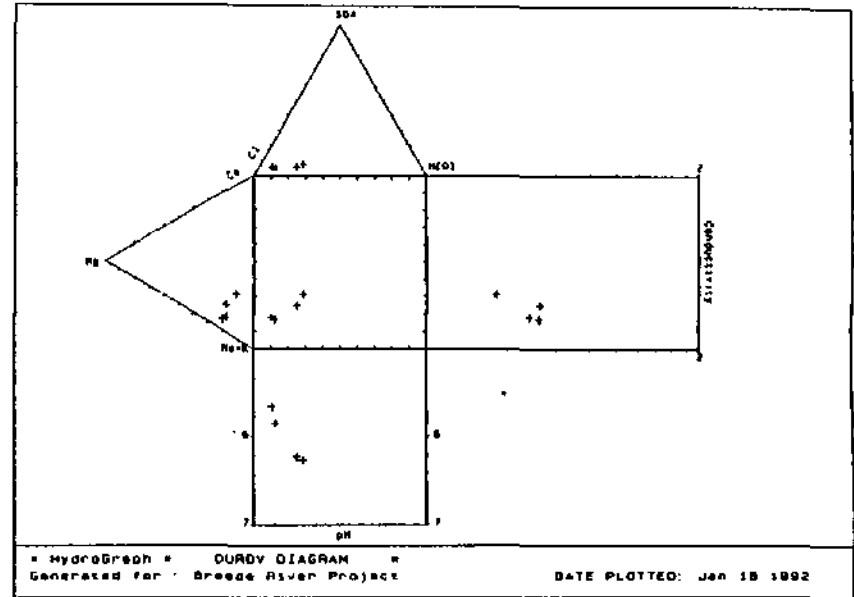
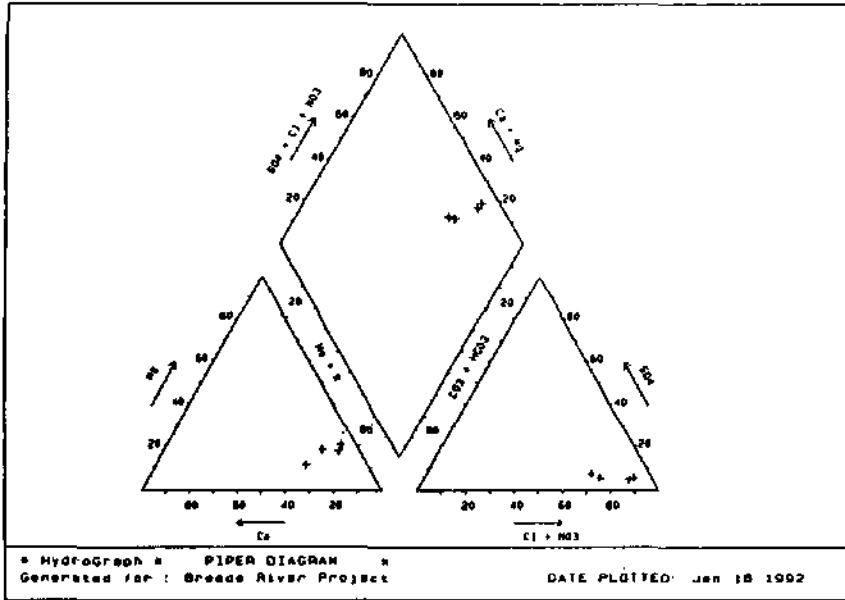

ENON : 3319DD01594

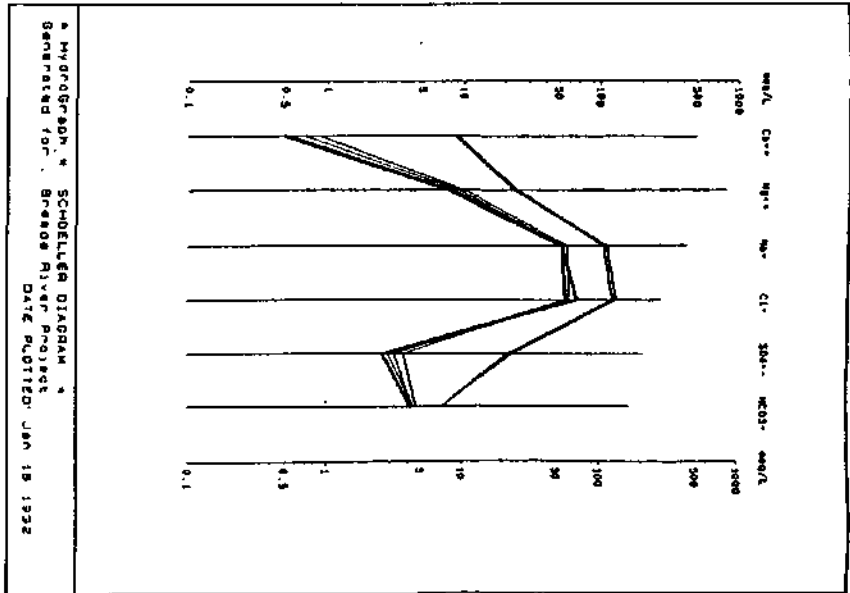
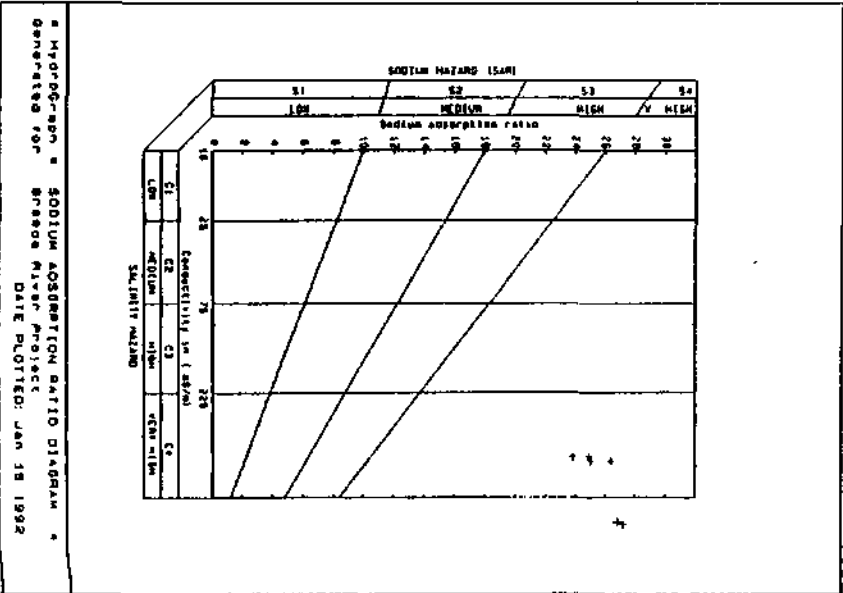
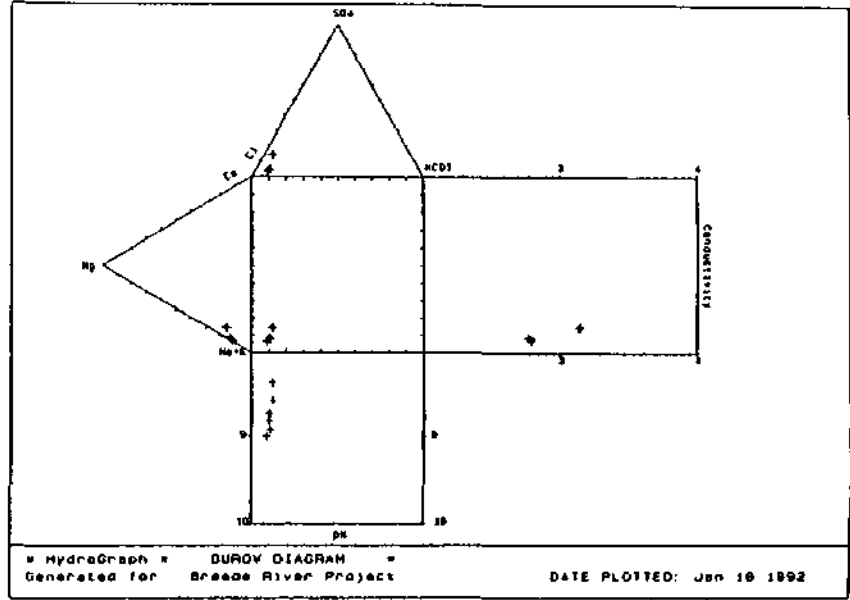
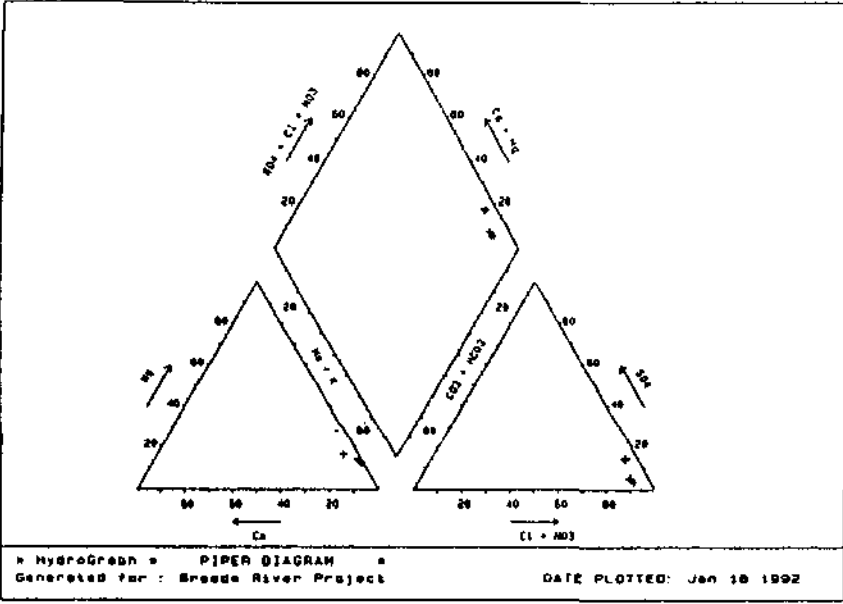

ENON : 3319DD00015

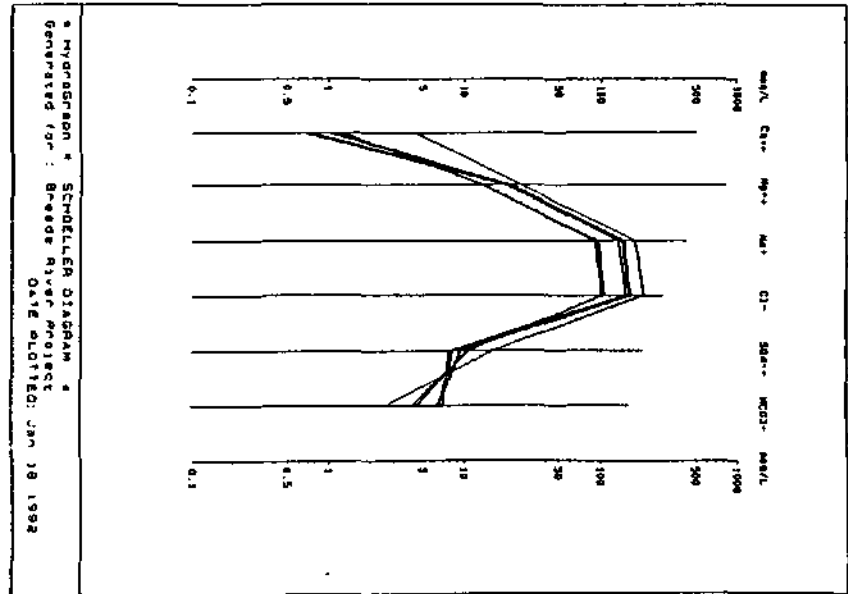
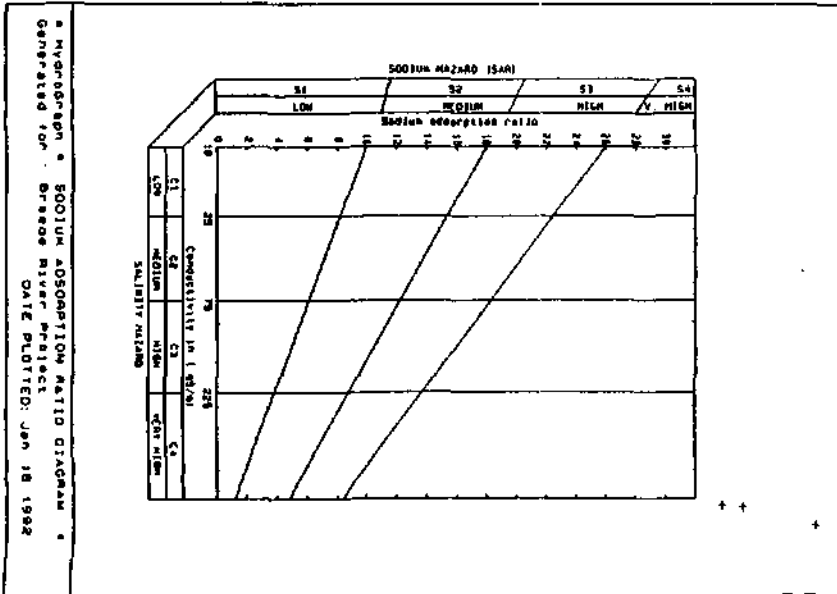
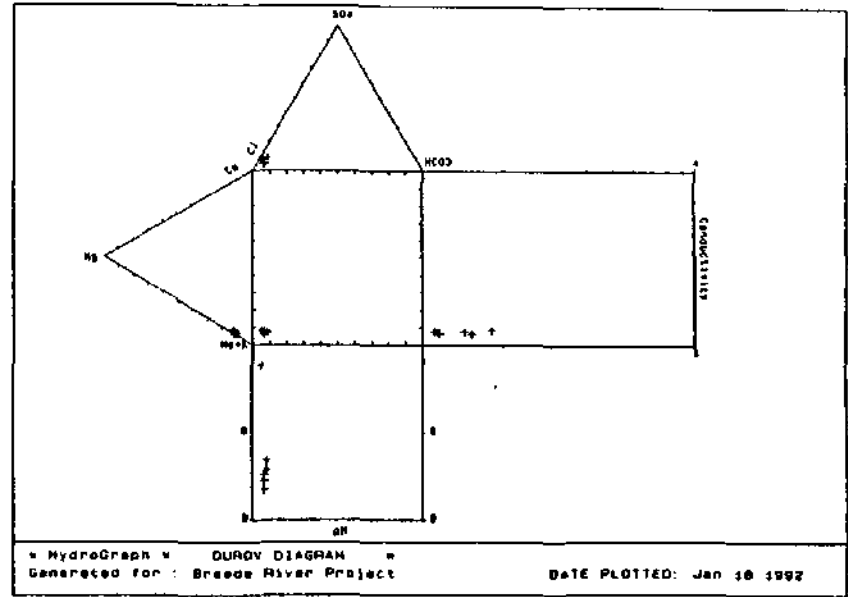
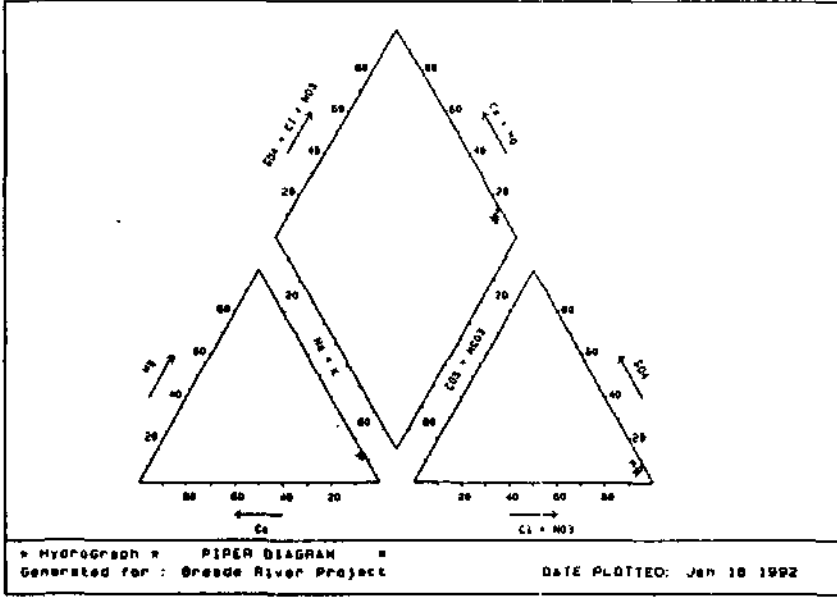

ENON : 3319DD00014

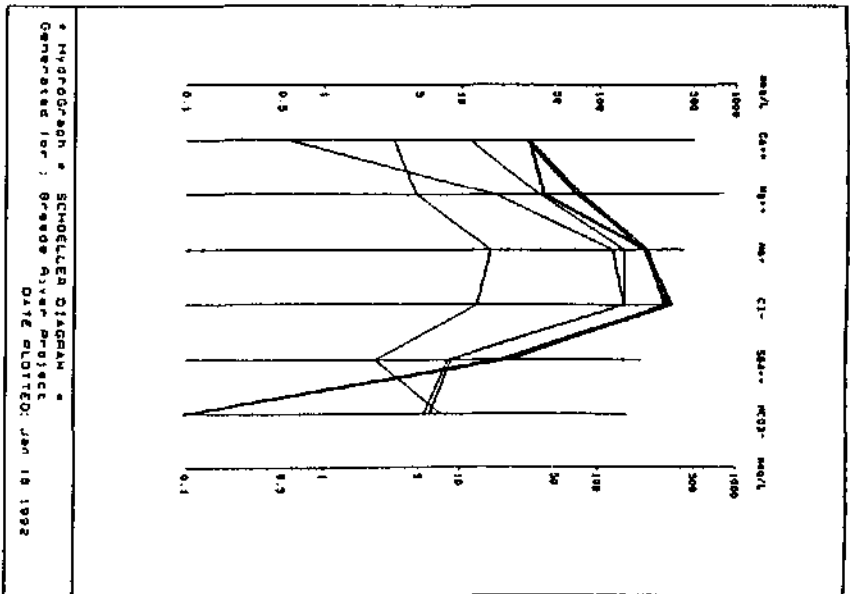
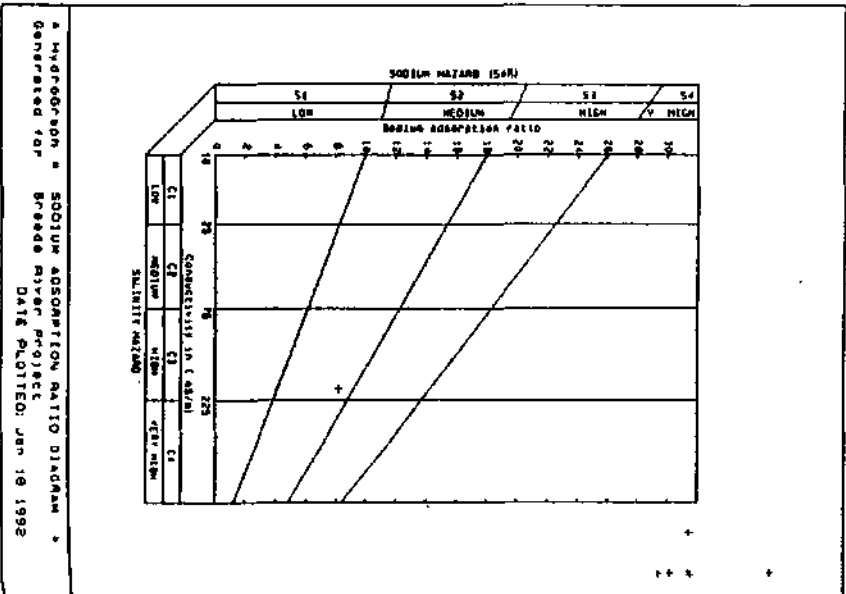
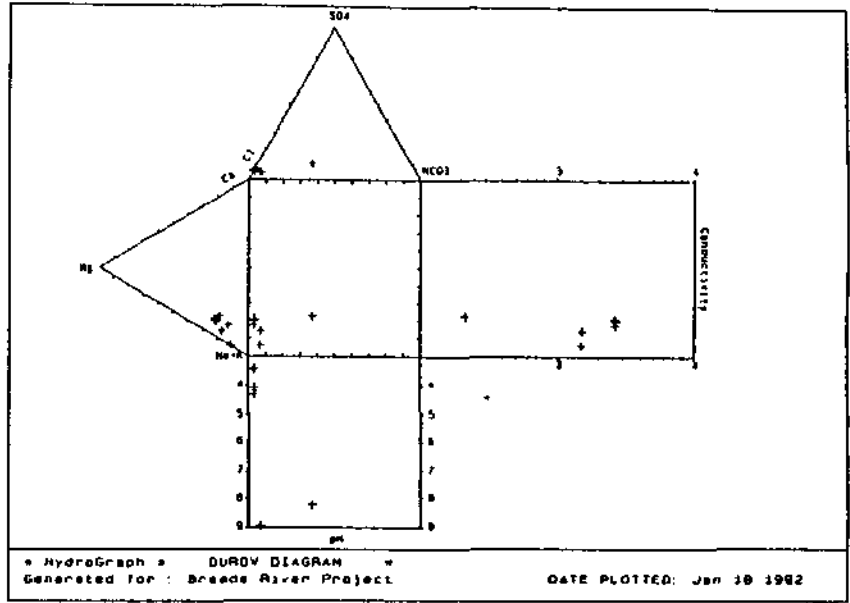
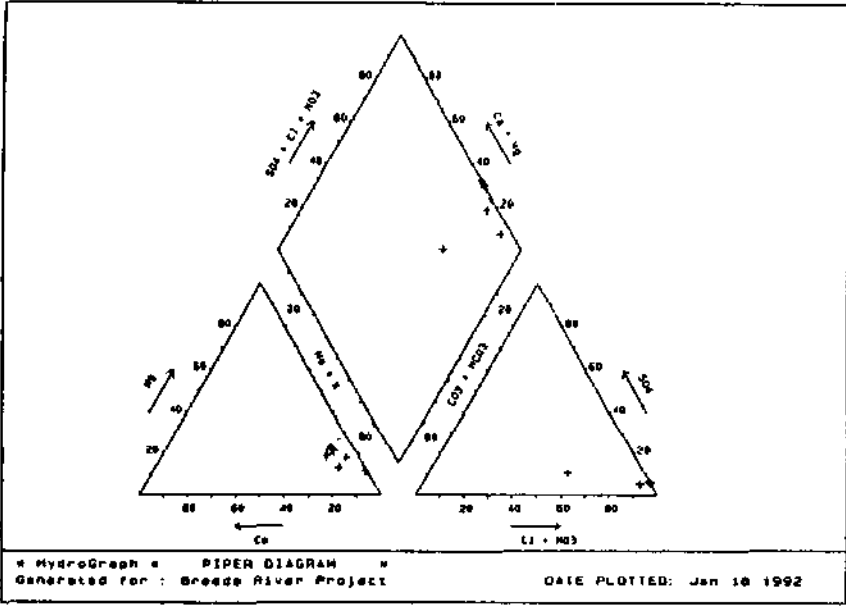

ENON : 3319DD00007

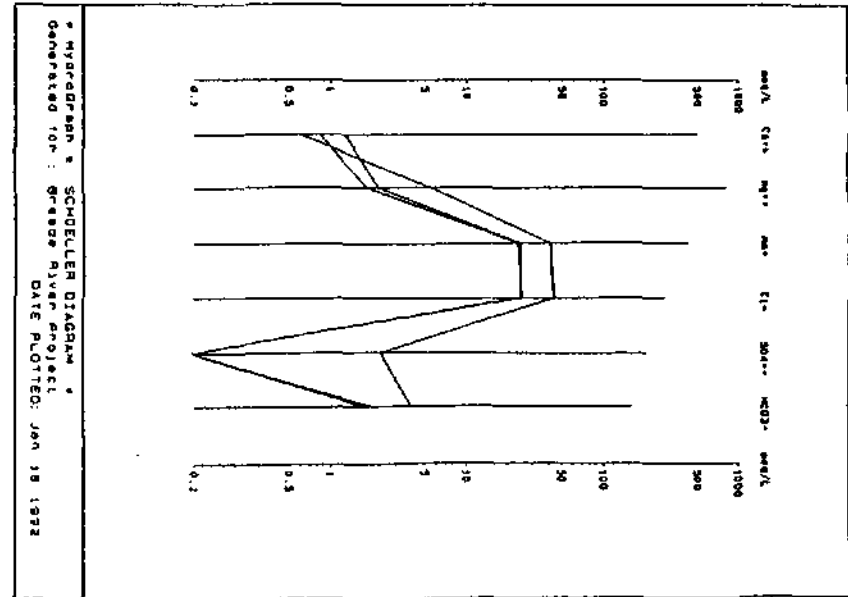
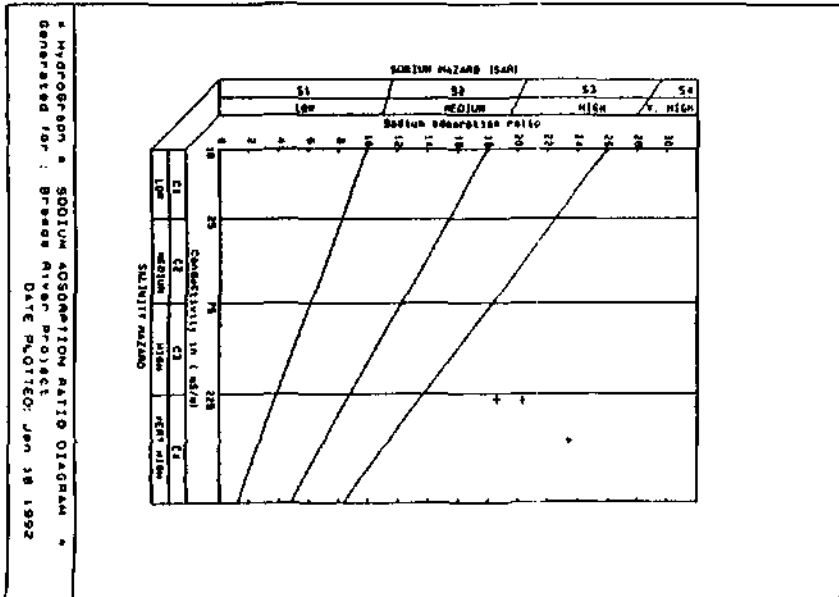
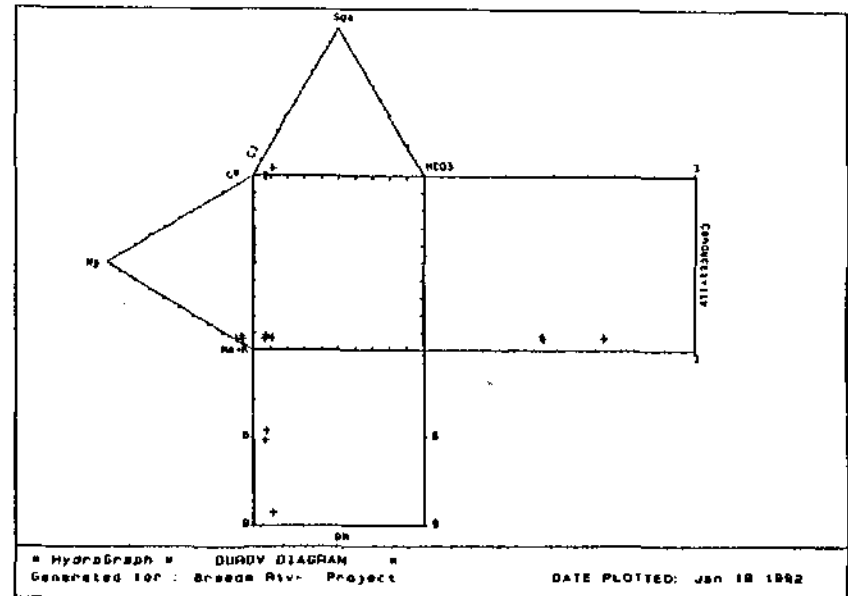
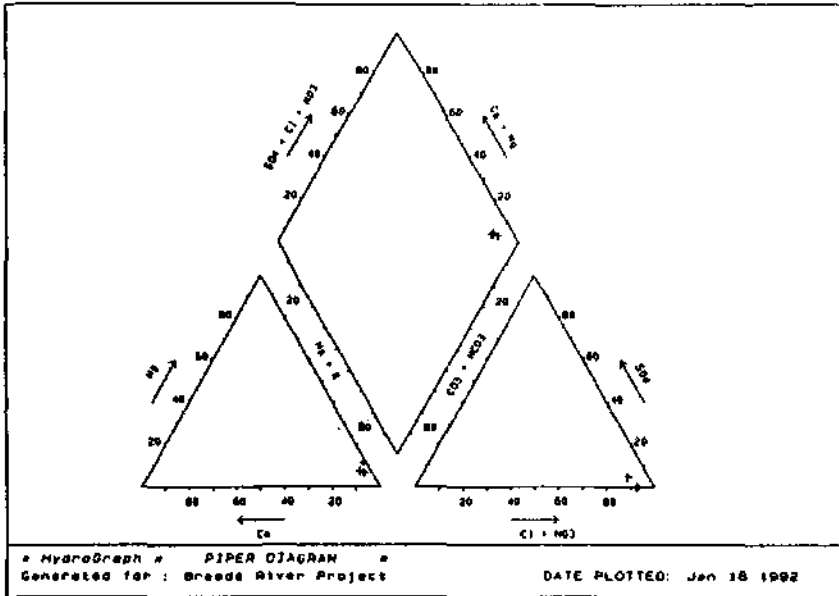

ENON : 3319DD00004

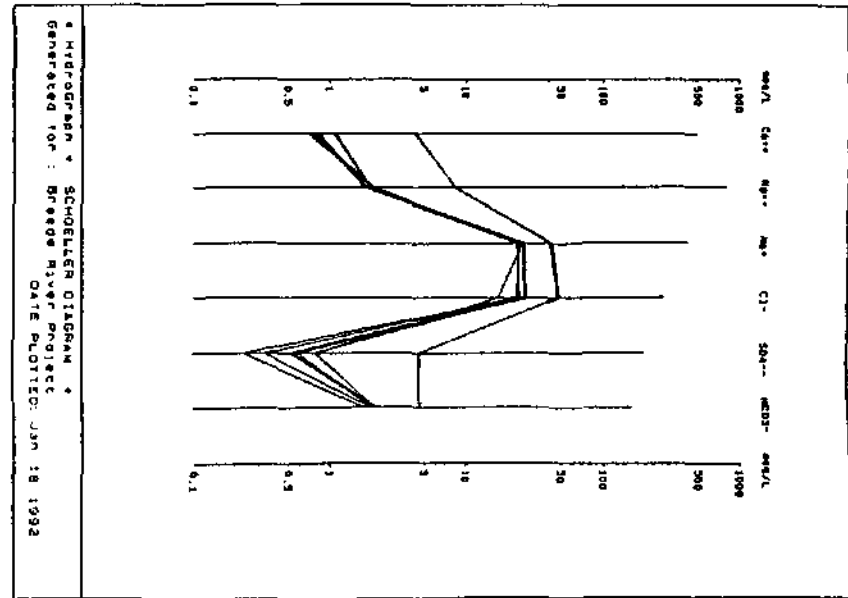
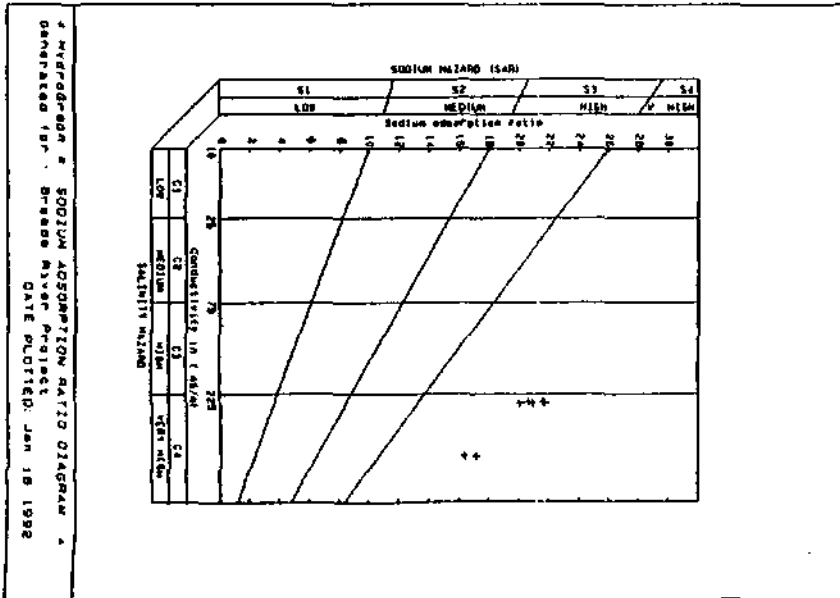
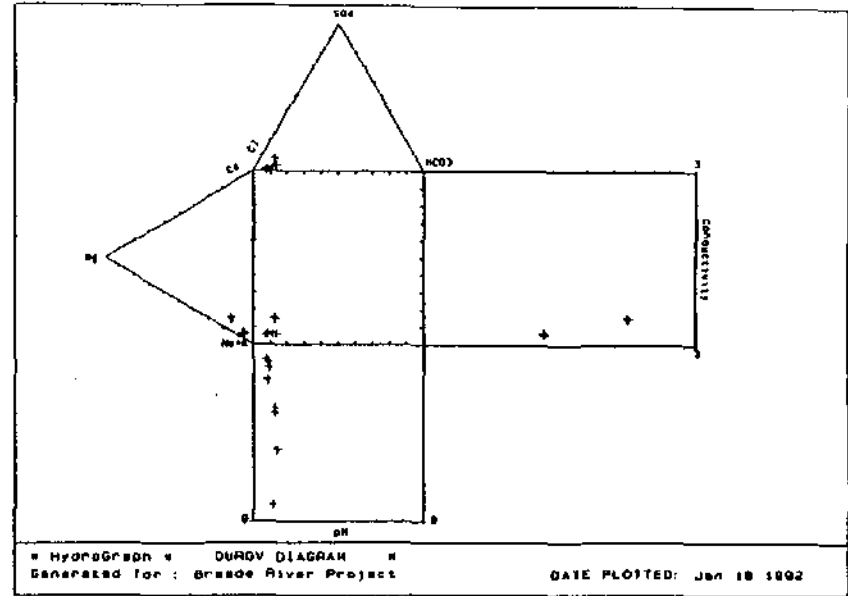
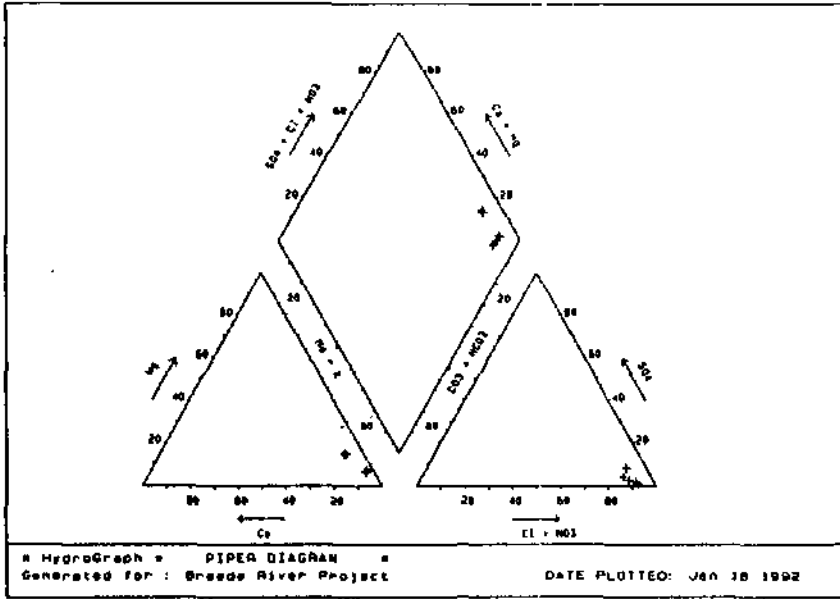

ENON : 3319DD00003

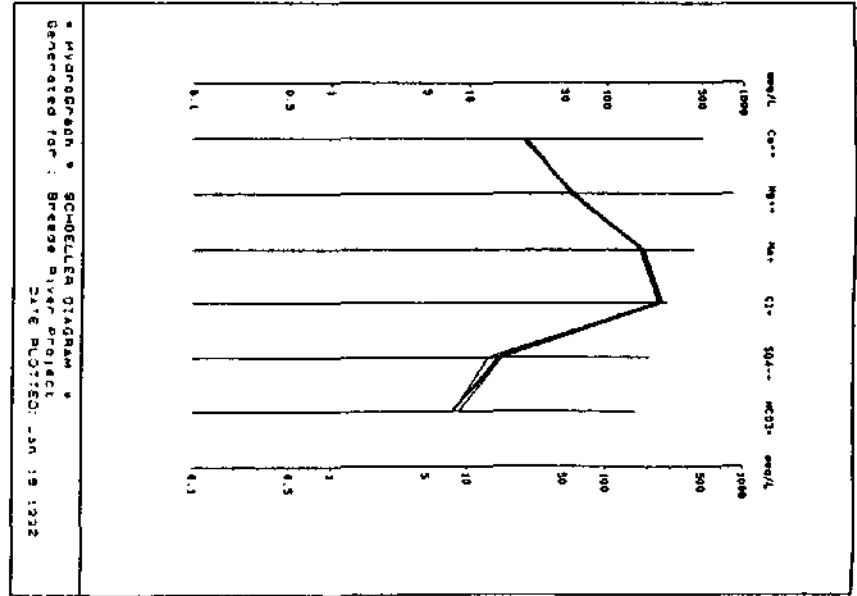
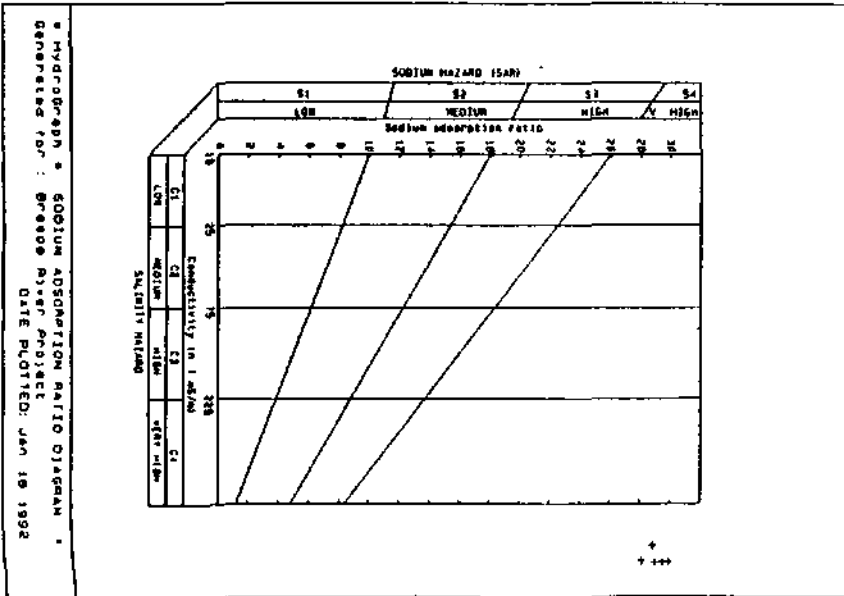
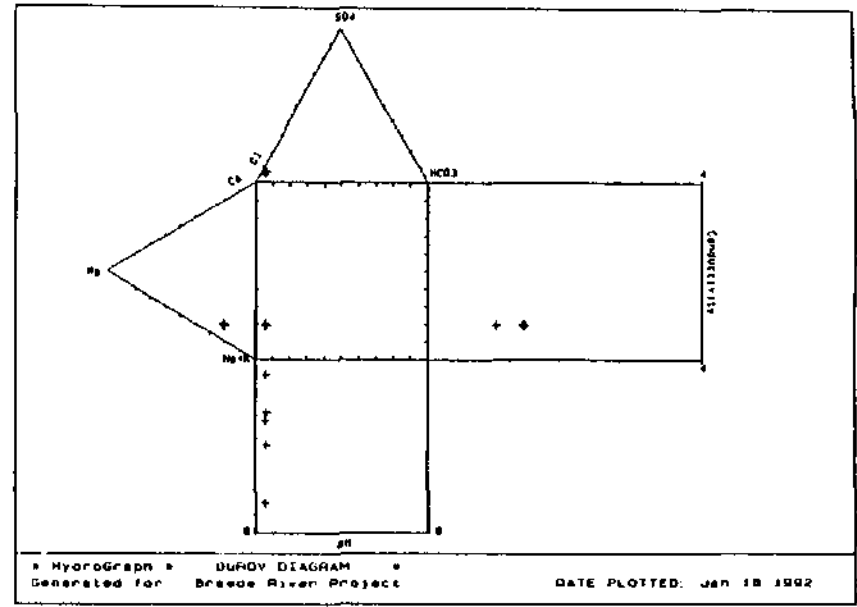
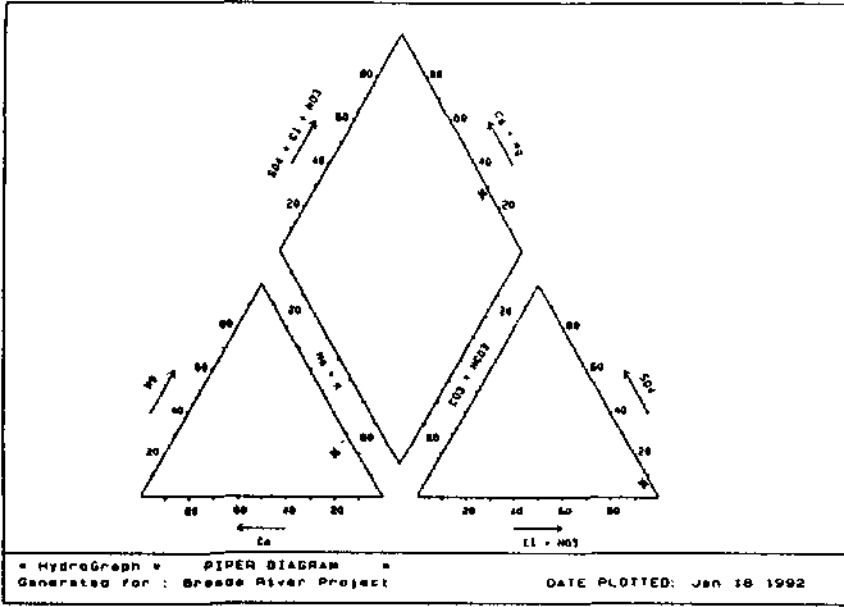

Appendix 12

Hydrochemical graphs: Surface water

H4H017

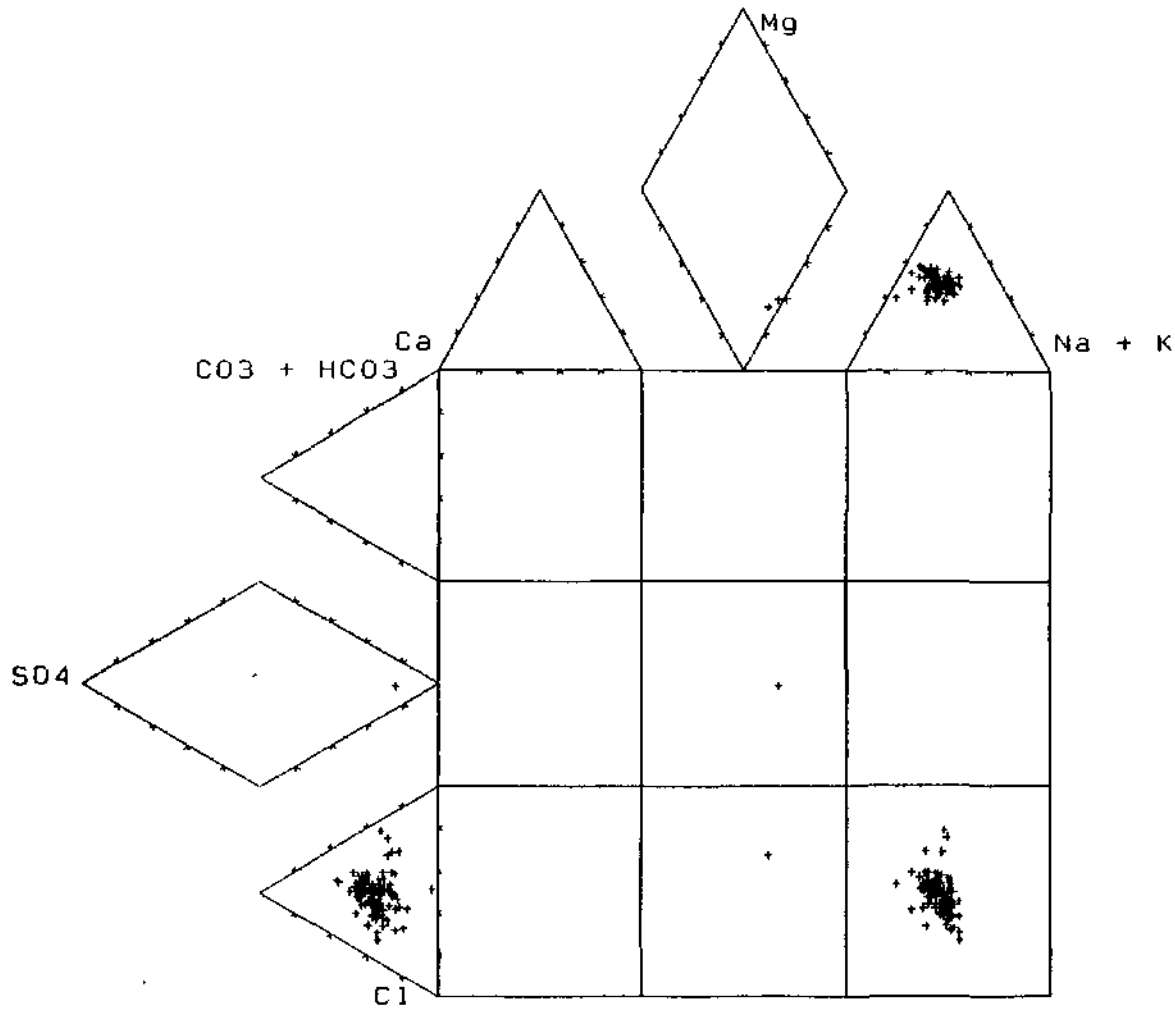

304

* HydroBase * EXPANDED DUROV DIAGRAM *
Generated for : Breede River Project

DATE PLOTTED: Jan 21 1992

H4H017

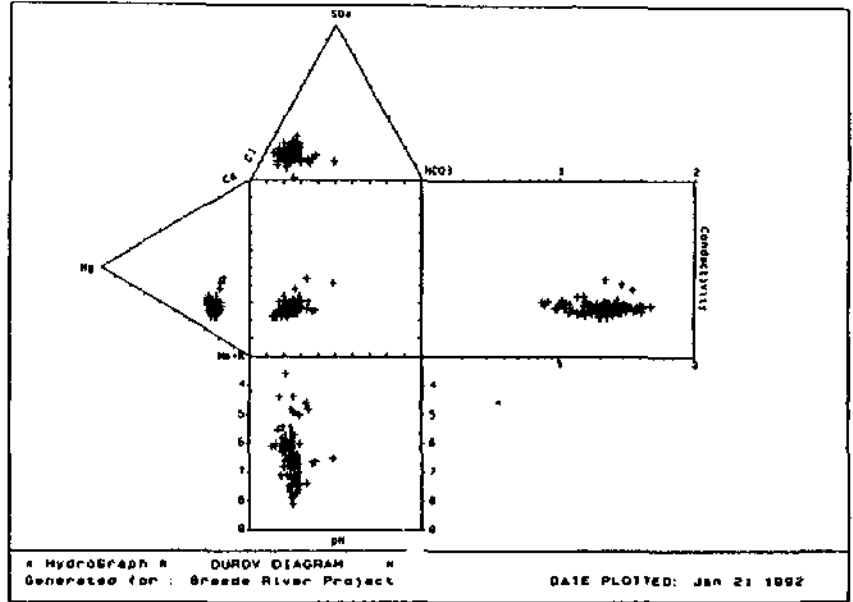
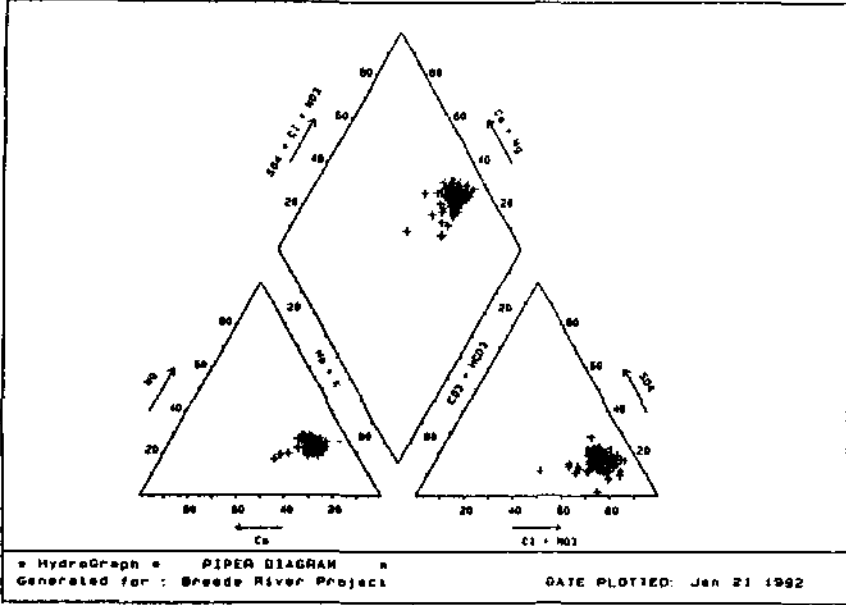

305

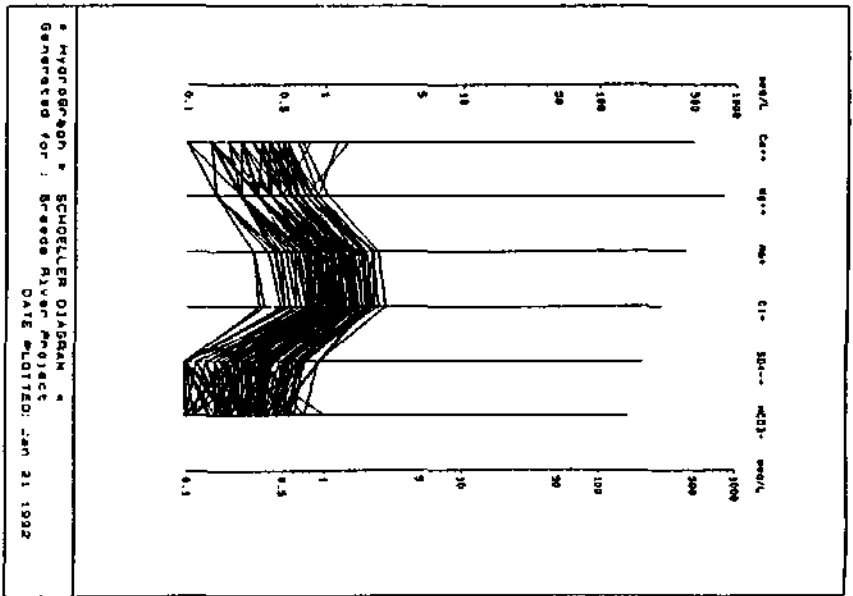
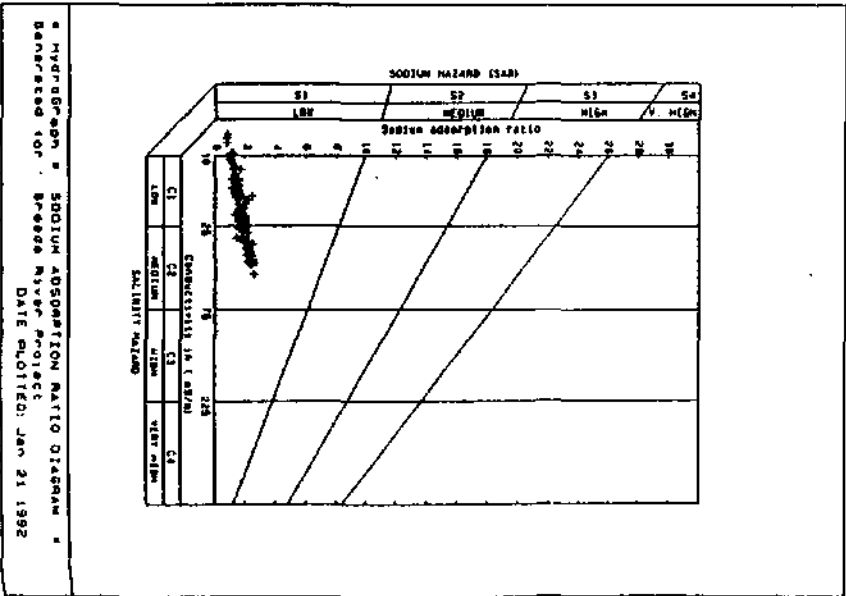

H4H018

306

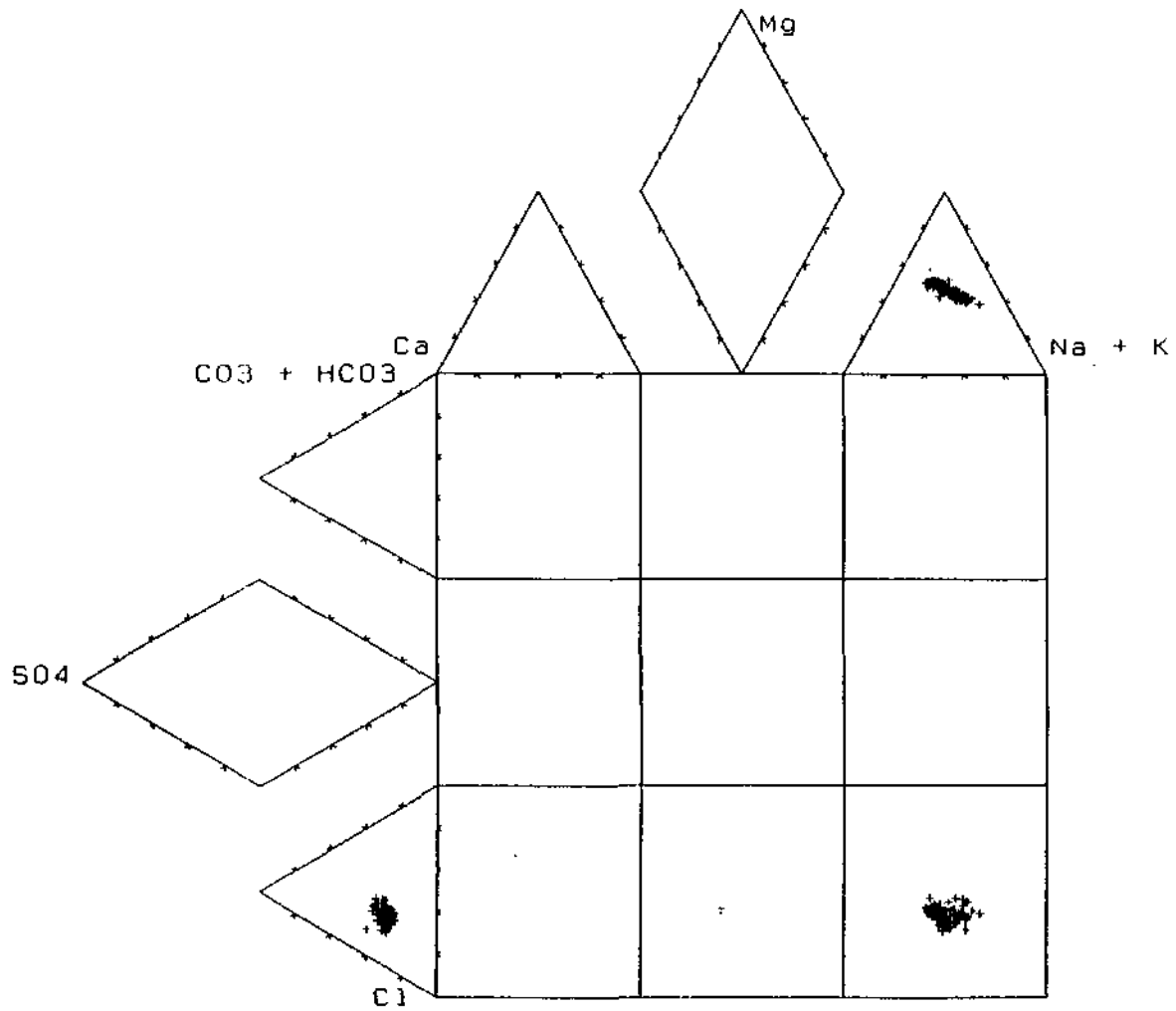

* HydroBase * EXPANDED DUROV DIAGRAM *
Generated for : Breede River Project

DATE PLOTTED: Jan 21 1992

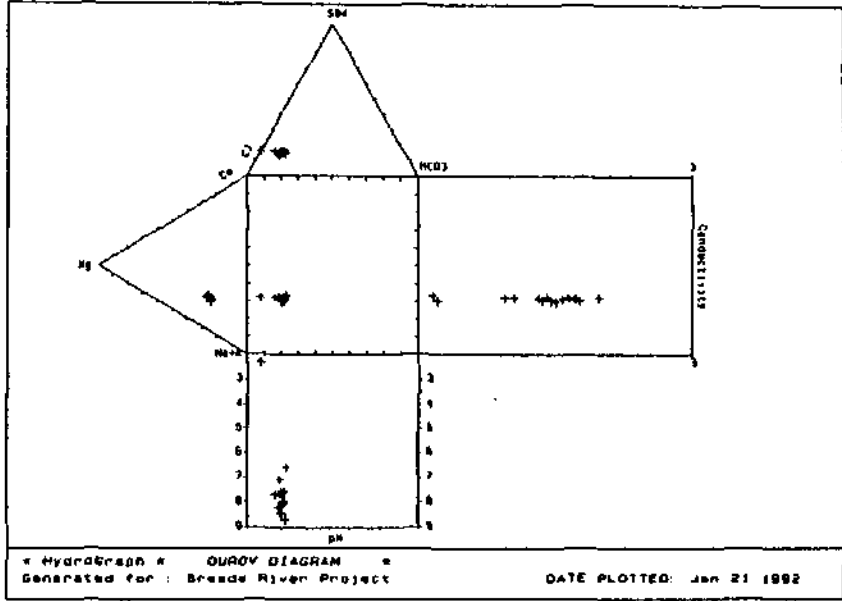
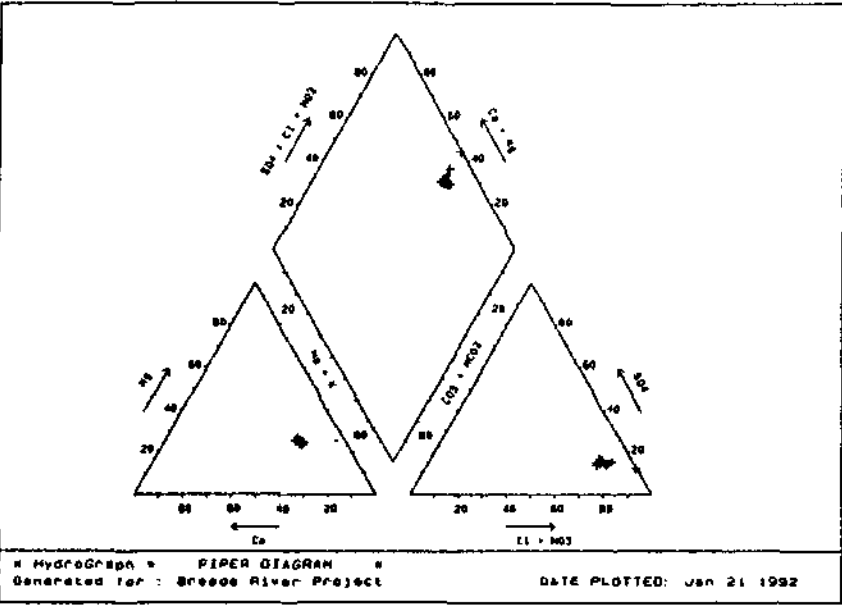

307

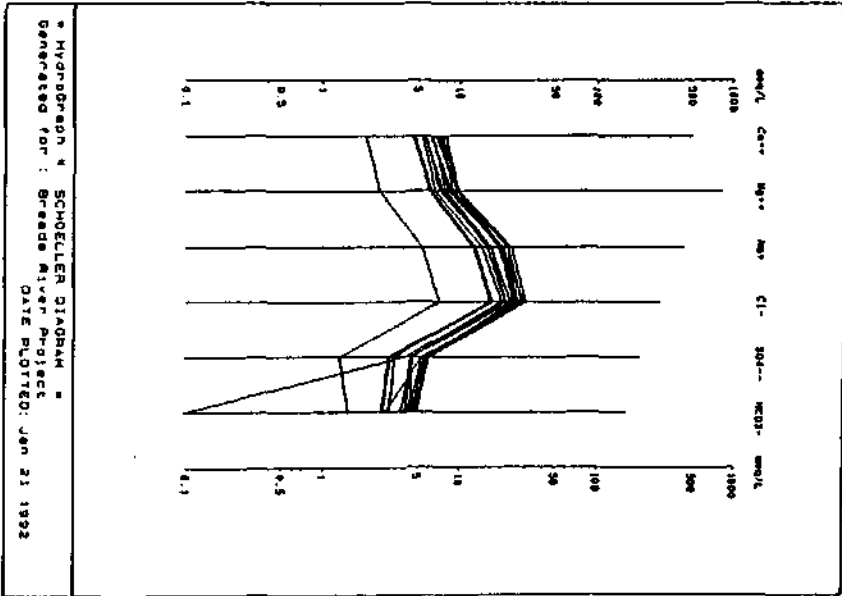
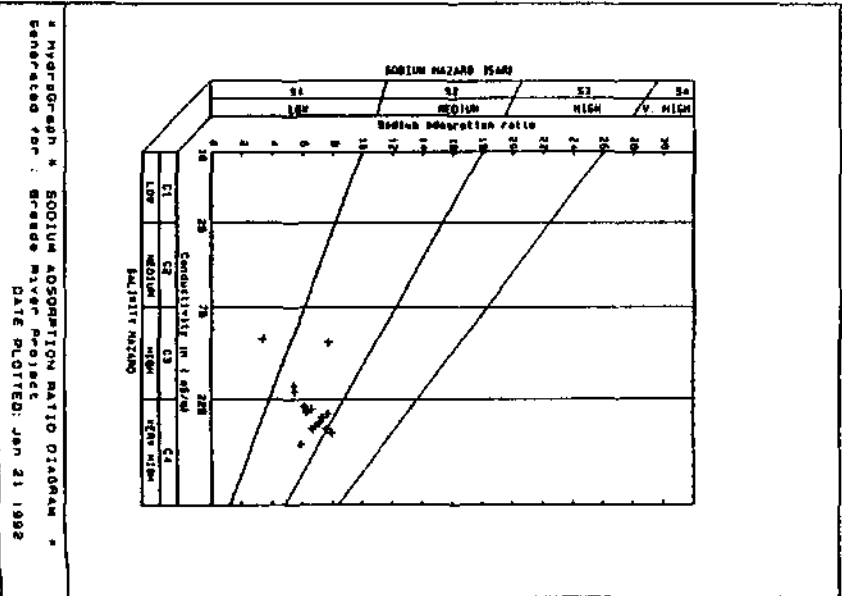

H3H011

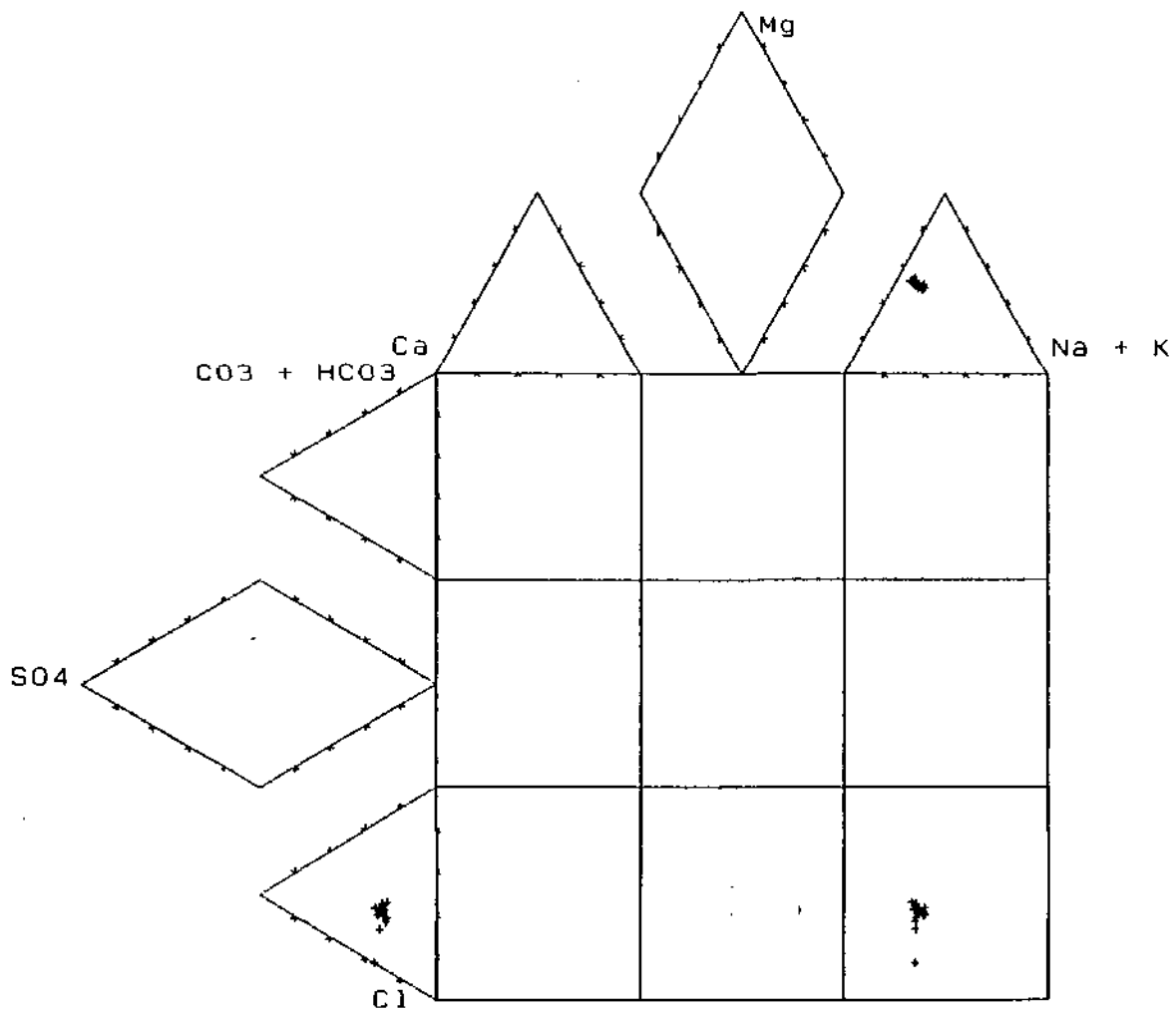

* HydroBase * EXPANDED DURUV DIAGRAM *
Generated for : Breede River Project

DATE PLOTTED: Jan 21 1992

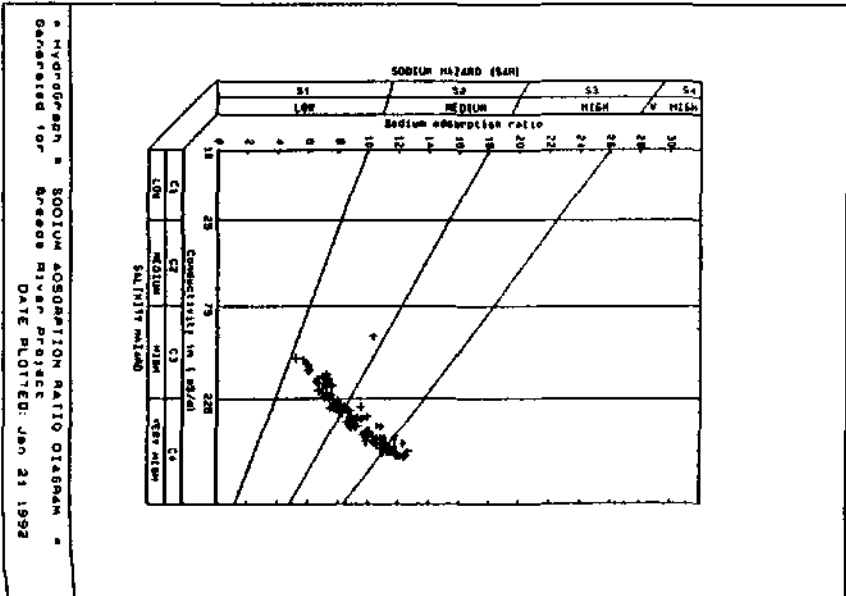
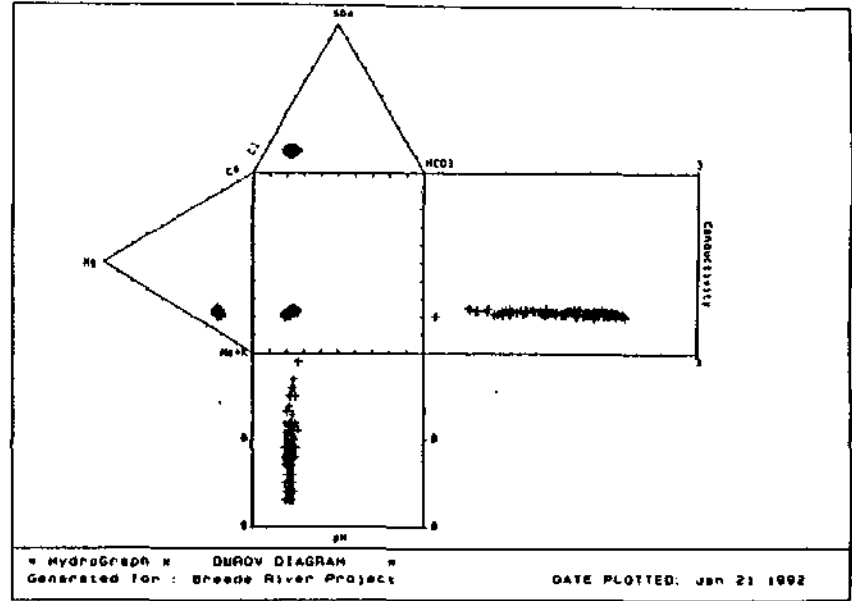
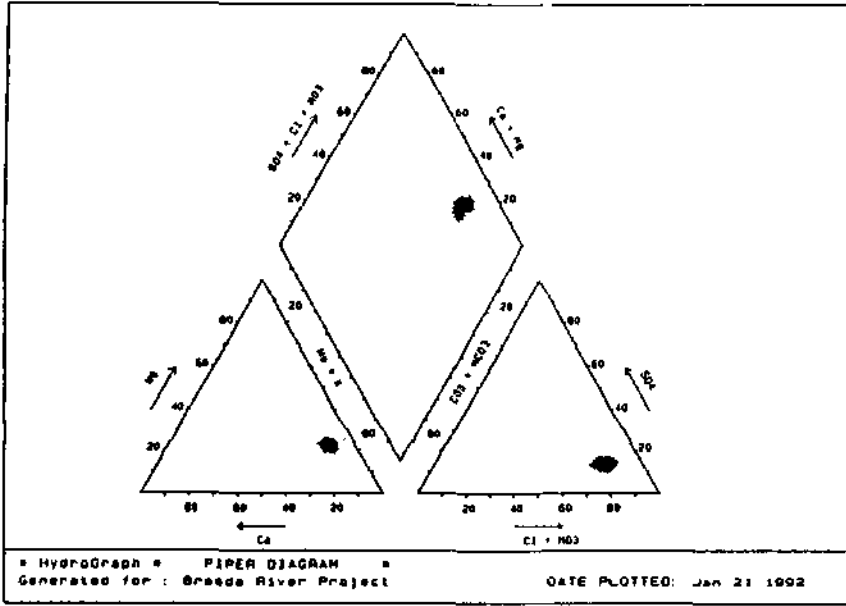

H5H004

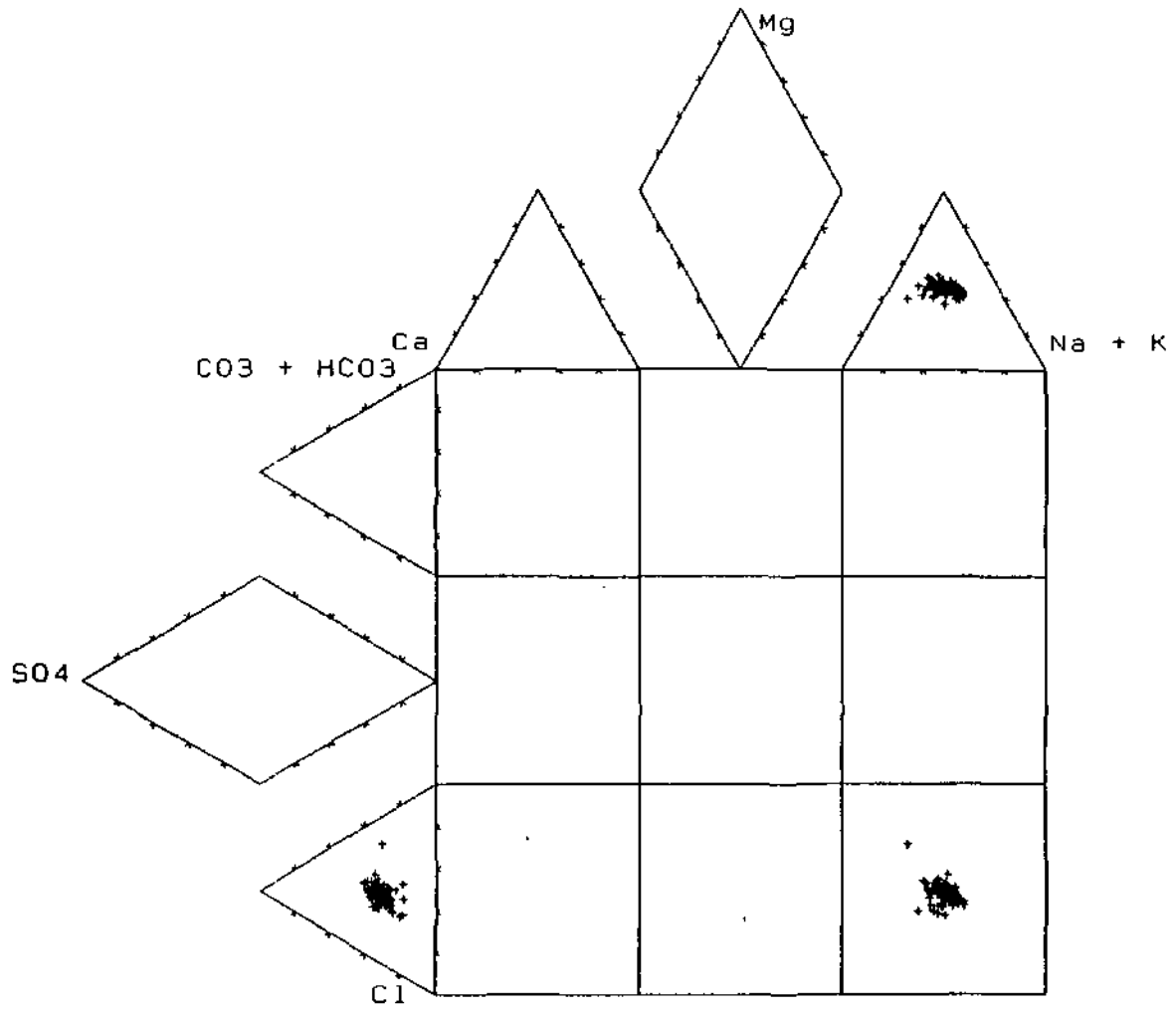

* HydroBase * EXPANDED DUROV DIAGRAM * DATE PLOTTED: Jan 21 1992
Generated for : Breede River Project

310

Appendix 13

Isotope analyses:

^2H and ^{18}O

 Data from file ISOTOPE_ :

SITE_ID_NR	DATE_MEAS	TIME_MEAS	DELTA_O_18	DEUTERIUM	SAMPLE_NO
3319CB00100	19900530	1130	-4.50	-24.0	H1R01Y (A)
3319CB00100	19900903	1530	-4.20	-25.0	H1R01Y (A)
3319CB00100	19910226	1415	1.70	6.0	H1R01Y (A)
3319CB00102	19881024	1130	3.60	-16.0	CSIR 4247
3319CB00102	19890425	1000	-5.90	-33.0	S4267
3319CD00026	19900607	0930	-4.40	-30.0	JF01
3319CD00027	19900607	0930	-5.50	-30.0	JF02
3319CD00101	19881024	1200	-0.20	-2.0	CSIR 4248
3319CD00101	19890425	1010	1.50	7.0	S4268
3319CD00101	19900530	1225	-0.40	-4.0	2
3319CD00101	19900903	1600	-1.60	-10.0	2
3319CD00101	19901202	1800	-1.90	-12.0	2
3319CD00101	19910226	1500	-0.60	-5.0	2
3319CD00102	19890425	1015	-5.80	-34.0	S4269
3319DA00002	19900605	1300	-7.10	-41.0	NG01
3319DA00003	19900605	1215	-7.00	-42.0	NG02
3319DA00004	19900605	1200	-7.00	-42.0	NG03
3319DA00004	19900905	0000	-6.90	-42.0	NG03
3319DA00004	19901200	0000	-5.90	-35.0	NG03
3319DA00004	19910301	1000	-7.20	-41.0	NG03
3319DA00005	19900605	1130	-6.80	-42.0	NG04
3319DA00005	19900905	0000	-7.00	-41.0	NG04
3319DA00005	19901206	0000	-6.10	-37.0	NG05
3319DA00005	19910301	1015	-7.10	-40.0	NG04
3319DA00006	19900605	1100	-7.00	-41.0	NG05
3319DA00006	19900905	0000	-7.00	-41.0	NG05
3319DA00006	19901200	0000	-6.10	-37.0	NG05
3319DA00006	19910301	1030	-7.20	-40.0	NG05
3319DA00007	19900605	0000	-7.00	-42.0	NG06
3319DA00008	19900605	0930	-6.70	-42.0	VR01
3319DA00008	19900903	1330	-7.00	-42.0	VR01
3319DA00008	19901203	1215	-7.20	-42.0	VR01
3319DA00008	19910226	0000	-7.00	-42.0	VR01
3319DA00101	19881024	1300	-4.30	-22.0	CSIR 4249
3319DA00101	19890425	1200	-5.90	-39.0	S4270
3319DB00005	19900531	0000	-5.00	-28.0	KD01
3319DB00005	19900903	1130	-5.00	-28.0	KD01
3319DB00005	19901203	1040	-5.10	-32.0	KD01
3319DB00005	19910226	0930	-5.10	-27.0	KD01
3319DB00007	19900531	1545	-5.20	-28.0	KD03
3319DB00007	19900903	1145	-5.40	-32.0	KD03
3319DB00007	19901203	1025	-5.40	-34.0	KD03
3319DB00007	19910226	0950	-5.30	-27.0	KD03
3319DB00011	19881024	1400	-4.30	-24.0	CSIR 2697
3319DB00011	19890425	1300	-4.50	-26.0	G2759
3319DB00011	19900531	0000	-5.00	-29.0	NE03
3319DB00011	19900903	0915	-4.90	-29.0	NE03
3319DB00011	19901200	0000	-4.60	-25.0	NE03
3319DB00011	19910301	0000	-5.10	-27.0	NE03
3319DB00012	19900531	0000	-4.20	-17.0	NE02
3319DB00012	19900903	0930	-4.70	-28.0	NE02
3319DB00012	19901200	0000	-4.50	-26.0	NE02
3319DB00012	19910301	0000	-4.90	-26.0	NE02
3319DB00013	19900531	0000	-4.80	-22.0	NE01
3319DB00013	19900903	0915	-4.90	-28.0	NE01
3319DB00013	19901206	0000	-4.30	-24.0	NE01
3319DB00013	19910301	0000	-4.90	-25.0	NE01
3319DB00016	19900605	0830	-6.00	-36.0	NE08
3319DB00016	19900903	1245	-6.10	-37.0	NE08
3319DB00016	19901203	1120	-6.20	-34.0	NE08
3319DB00016	19910226	1100	-6.00	-35.0	NE08
3319DB00102	19881024	1430	-5.00	-17.0	CSIR 4251
3319DB00102	19890425	1315	-4.90	-26.0	G2760
3319DB00102	19900531	0000	-4.80	-25.0	7 (F1)
3319DB00102	19900903	1100	-5.20	-29.0	7 (F1)
3319DB00102	19901200	0000	-3.90	-26.0	7 (F1)
3319DB00102	19910226	1030	-4.70	-26.0	7 (F1)
3319DC00002	19881025	1500	-6.50	-35.0	CSIR 2701

3319DC00002	19890426	1230	-5.30	-31.0	S2765
3319DC00006	19890426	1220	-6.90	-38.0	G2770
3319DC00006	19900601	0000	-6.80	-39.0	DN06
3319DC00006	19900905	1140	-6.80	-38.0	DN06
3319DC00006	19901205	1330	-6.90	-44.0	DN06
3319DC00006	19910227	1300	-6.90	-30.0	DN06
3319DC00007	19881025	1430	-6.50	-38.0	CSIR 2700
3319DC00007	19890426	1200	-6.40	-38.0	S2763
3319DC00007	19900601	1320	-6.30	-40.0	DN07
3319DC00007	19900905	1000	-6.40	-38.0	DN07
3319DC00007	19910227	1145	-6.30	-37.0	DN07 (86)
3319DC00008	19900601	0000	-3.70	-25.0	DN08
3319DC00008	19900905	1015	-3.70	-24.0	DN08
3319DC00008	19910227	1130	-3.50	-23.0	DN08
3319DC00010	19900601	1600	-4.10	-25.0	PR01
3319DC00010	19900905	1430	-5.00	-31.0	PR01
3319DC00010	19901205	1515	-4.00	-24.0	PR01
3319DC00010	19910227	1600	-4.80	-27.0	PR01
3319DC00027	19900602	0000	-6.60	-38.0	PR18
3319DC00027	19900905	1235	-6.60	-42.0	PR18
3319DC00027	19901205	1350	-6.90	-38.0	PR18
3319DC00027	19910227	1335	-6.80	-38.0	PR18
3319DC00028	19900604	0000	-7.60	-47.0	PY01
3319DC00028	19900907	1545	-6.50	-42.0	PY01
3319DC00028	19901206	1150	-6.70	-36.0	PY01
3319DC00028	19910305	1000	-6.70	-37.0	PY01
3319DC00030	19900604	0000	-6.20	-35.0	RY01
3319DC00030	19900907	1345	-6.20	-38.0	RY01
3319DC00030	19901206	1345	-6.30	-34.0	RY01
3319DC00030	19910305	1315	-6.20	-36.0	RY01
3319DC00033	19900604	0000	-2.20	-19.0	RY04
3319DC00033	19900907	1415	-6.20	-38.0	RY04
3319DC00033	19901206	1355	-6.50	-37.0	RY04
3319DC00033	19910305	1345	-6.30	-37.0	RY04
3319DC00037	19900604	1030	-3.50	-25.0	RY08
3319DC00039	19900604	0945	-5.90	-34.0	RY10
3319DC00039	19900907	1205	-5.70	-33.0	RY10
3319DC00041	19900907	1210	-5.60	-34.0	RY12 (V)
3319DC00041	19901206	1530	-5.40	-31.0	RY12 (V)
3319DC00041	19910305	1120	-5.50	-32.0	RY12 (V)
3319DC00101	19881025	0900	-2.30	-12.0	CSIR 4255
3319DC00101	19890426	1030	-4.10	-35.0	S4273
3319DC00101	19900601	1045	-2.50	-17.0	POESJENELS
3319DC00101	19900905	1610	-3.60	-25.0	POESJENELS
3319DC00101	19900925	1504	-2.60	-26.0	POESJENEL H4M18
3319DC00101	19901205	0845	-2.60	-14.0	POESJENELS
3319DC00101	19910302	1230	-2.10	-15.0	POESJENELS
3319DC00102	19881025	0930	-3.40	-17.0	CSIR 4256
3319DC00102	19890426	1130	-5.90	-33.0	S4276
3319DC00102	19900601	1715	-4.40	-22.0	LE CHASSEUR
3319DC00102	19900905	1540	-4.10	-21.0	LE CHASSEUR
3319DC00102	19901205	0800	-2.00	-13.0	LE CHASSEUR
3319DC00102	19910302	1100	-0.50	-5.0	LE CHASSEUR
3319DC00104	19890426	1215	-6.60	-38.0	S2764
3319DC00107	19900607	1045	-6.20	-39.0	AB
3319DC00107	19900905	1515	-6.20	-40.0	AB
3319DC00107	19901205	0830	-6.50	-41.0	AB
3319DC00107	19910302	1200	-6.20	-37.0	AB
3319DC00108	19900602	0000	-6.30	-37.0	U
3319DC00108	19900905	1200	-6.60	-39.0	U
3319DC00108	19901205	1335	-6.70	-40.0	U
3319DC00108	19910227	1305	-6.60	-39.0	U
3319DC00110	19900604	0000	-6.30	-34.0	Y
3319DC00110	19900907	1615	-6.20	-38.0	Y
3319DC00110	19901206	1220	-6.40	-36.0	Y
3319DC00110	19910305	1015	-6.30	-35.0	Y
3319DD00001	19900608	1330	-5.10	-34.0	AK
3319DD00033	19900605	0000	-5.50	-33.0	GE01
3319DD00033	19900906	1600	-6.00	-33.0	GE01
3319DD00033	19910226	1530	-6.00	-32.0	GE01
3319DD00035	19900608	1240	-5.30	-29.0	KR01
3319DD00035	19900906	1500	-5.80	-32.0	KR01
3319DD00035	19901206	0950	-4.40	-24.0	KR01
3319DD00035	19910304	1700	-5.50	-29.0	KR01

3319DD00042	19890426	0930	-4.50	-24.0	G2769
3319DD00042	19900606	1130	-4.30	-24.0	MD07
3319DD00042	19900904	1030	-4.50	-24.0	MD07
3319DD00042	19901204	1025	-4.70	-25.0	MD07
3319DD00042	19910228	1200	-4.60	-25.0	MD07 (B10)
3319DD00043	19900606	1215	-5.00	-29.0	MD08
3319DD00043	19900904	1200	-5.10	-31.0	MD08
3319DD00043	19901204	1025	-4.70	-25.0	MD08
3319DD00045	19900609	1015	-4.90	-25.0	DP04
3319DD00045	19900906	0930	-4.70	-22.0	DP04
3319DD00045	19910304	0845	-5.10	-23.0	DP04
3319DD00047	19900608	0000	-4.80	-25.0	DP06
3319DD00047	19900907	0730	-4.80	-21.0	DP06
3319DD00047	19901203	1300	-4.80	-26.0	DP06
3319DD00047	19910304	1400	-4.50	-22.0	DP06
3319DD00049	19900607	1500	-5.60	-34.0	DP08
3319DD00050	19881026	0900	-4.50	-22.0	CSIR 2702
3319DD00050	19890426	1400	-4.80	-24.0	G2766
3319DD00050	19900607	1345	-4.80	-25.0	DP09
3319DD00050	19900907	0830	-4.70	-24.0	DP09
3319DD00050	19901206	0000	-5.00	-27.0	DP09
3319DD00050	19910304	1600	-5.10	-26.0	DP09
3319DD00051	19881026	1140	-5.40	-18.0	CSIR 2704
3319DD00051	19890426	1340	-5.50	-28.0	G2768
3319DD00051	19900607	1530	-4.50	-22.0	RE01
3319DD00051	19900906	1030	-4.20	-23.0	RE01
3319DD00051	19901203	1600	-3.00	-13.0	RE01
3319DD00051	19910304	1245	-5.00	-27.0	RE01 (B4)
3319DD00052	19881026	1130	3.60	-16.0	CSIR 2703
3319DD00052	19890426	1330	-2.30	-12.0	G2767
3319DD00052	19900607	1530	-3.00	-14.0	RE02
3319DD00052	19900906	1015	-3.40	-12.0	RE02
3319DD00052	19901203	1615	-3.70	-19.0	RE02
3319DD00053	19900606	1230	-5.60	-30.0	RL01
3319DD00053	19900904	1230	-5.70	-34.0	RL01
3319DD00053	19901204	1130	-6.20	-33.0	RL01
3319DD00053	19910228	1030	-6.20	-33.0	RL01
3319DD00054	19900606	1530	-5.60	-32.0	TY01
3319DD00054	19900904	1445	-6.70	-37.0	TY01
3319DD00054	19901204	1400	-6.80	-40.0	TY01
3319DD00054	19910228	0900	-6.80	-40.0	TY01
3319DD00055	19900606	1500	-6.70	-40.0	TY02
3319DD00055	19900904	1415	-6.60	-40.0	TY02
3319DD00055	19901204	1415	-7.00	-39.0	TY02
3319DD00055	19910228	0910	-6.70	-39.0	TY02
3319DD00057	19900606	1515	-6.80	-41.0	TY04
3319DD00057	19900904	1430	-6.40	-39.0	TY04
3319DD00057	19901204	1430	-6.80	-40.0	TY04
3319DD00057	19910228	0905	-6.40	-39.0	TY04
3319DD00058	19900606	1000	-5.20	-29.0	VD02
3319DD00058	19900904	0915	-3.80	-25.0	VD02
3319DD00058	19901204	0930	-4.00	-22.0	VD02
3319DD00058	19910228	1315	-5.60	-30.0	VD02
3319DD00059	19900606	1030	-5.70	-30.0	VD03
3319DD00059	19900904	0845	-5.80	-30.0	VD03
3319DD00059	19901204	0920	-5.10	-27.0	VD03
3319DD00059	19910228	1250	-5.90	-30.0	VD03
3319DD00060	19900606	1050	-3.40	-19.0	VD04
3319DD00060	19900904	1000	-3.30	-18.0	VD04
3319DD00060	19901204	1500	-3.50	-20.0	VD04
3319DD00060	19910228	1220	-2.50	-14.0	VD04
3319DD00066	19900601	0900	-6.10	-34.0	ZN01
3319DD00066	19900907	1100	-6.00	-36.0	ZN01
3319DD00066	19901205	1620	-6.20	-33.0	ZN01
3319DD00066	19910227	0945	-6.00	-32.0	ZN01
3319DD00067	19900601	0900	-5.50	-30.0	ZN02
3319DD00067	19900907	1100	-3.30	-23.0	ZN02
3319DD00067	19901205	1640	-4.40	-25.0	ZN02
3319DD00067	19910227	0935	-5.90	-34.0	ZN02
3319DD00068	19881025	0845	-6.20	-27.0	CSIR 2698
3319DD00068	19890426	1000	-6.10	-34.0	G2761
3319DD00068	19900601	0915	-6.20	-34.0	ZN03
3319DD00068	19900907	1000	-6.20	-35.0	ZN03
3319DD00068	19901205	1625	-6.40	-33.0	ZN03

3319DD00068	19910227	0920	-6.40	-35.0	ZN03
3319DD00105	19881024	1500	-4.00	-18.0	CSIR 4252
3319DD00105	19890426	1400	-5.70	-32.0	S4272
3319DD00106	19881025	1000	-2.70	-14.0	CSIR 4257
3319DD00106	19890426	1220	-5.50	-30.0	S4277
3319DD00106	19900530	1325	-3.40	-19.0	14
3319DD00106	19900905	1645	-3.80	-22.0	14 (VINK)
3319DD00106	19900926	0938	-4.00	-26.0	H4M19 (VINK)
3319DD00106	19901205	1030	-3.20	-18.0	H4M19 (VINK)
3319DD00106	19910304	1130	-2.20	-12.0	H4M19 (VINK)
3319DD00107	19881024	1330	-4.30	-12.0	CSIR 4250
3319DD00107	19890425	1230	-4.60	-25.0	S4271
3319DD00108	19881025	1200	-3.30	-10.0	CSIR 4258
3319DD00108	19890426	0915	-5.50	-30.0	S4278
3319DD00109	19881025	1130	-5.40	-31.0	CSIR 2699
3319DD00109	19890426	0830	-5.40	-32.0	G2762
3319DD00109	19900606	0830	-5.50	-32.0	15 (B5)
3319DD00109	19901204	0830	-5.80	-39.0	15 (B5)
3319DD00109	19910228	1415	-5.80	-32.0	15 (B5)
3319DD00111	19900605	0400	-4.30	-23.0	Z
3319DD00111	19900903	0830	-4.80	-26.0	Z
3319DD00111	19901203	0830	-4.50	-24.0	Z
3319DD00111	19910226	0850	-4.30	-23.0	Z
3319DD00112	19900605	1700	-4.40	-23.0	AA
3319DD00112	19900903	0840	-4.70	-27.0	AA
3319DD00112	19901203	0845	-4.90	-26.0	AA
3319DD00113	19900530	1400	-4.40	-22.0	NELS (B)
3319DD00113	19900905	1700	-4.00	-21.0	NELS (B)
3319DD00113	19901205	1100	-2.80	-14.0	NELS (B)
3319DD00113	19910304	1155	-2.50	-11.0	NELS (B)
3319DD00119	19900530	1625	-3.30	-14.0	KEISERS (C)
3319DD00119	19901205	1725	-1.00	-11.0	KEISERS (C)
3319DD00119	19910305	0825	-1.80	-12.0	KEISERS (C)
3319DD00124	19900604	0000	-6.20	-34.0	CD1A
3319DD00124	19900905	0950	-6.30	-34.0	CD1A
3319DD00124	19910227	1000	-6.30	-32.0	CD1A
3319DD00126	19900609	1015	-3.80	-21.0	HOOPS
3319DD00126	19900905	1625	-3.90	-22.0	HOOPS
3319DD00126	19901205	1105	-2.60	-16.0	HOOPS
3319DD00126	19910305	0810	-2.40	-13.0	HOOPS
3319DD00127	19900608	1000	-6.00	-32.0	KONINGS (AF)
3319DD00127	19900904	1630	-6.00	-35.0	KONINGS (AF)
3319DD00127	19901204	1530	-6.20	-38.0	KONINGS (AF)
3319DD00127	19910228	1445	-6.10	-30.0	KONINGS (AF)
3319DD00131	19900925	1146	-4.70	-29.0	ANG01
3320CC00101	19881025	0800	-3.20	-8.0	CSIR 4254
3320CC00101	19890426	1700	-5.60	-30.0	S4274
3320CC00101	19900608	1150	-6.10	-34.0	SECUNDA (AI)
3320CC00101	19900906	1315	-4.80	-28.0	SECUNDA (AI)
3320CC00101	19901206	0825	-1.60	-10.0	SECUNDA (AI)
3320CC00101	19910301	1550	-0.60	-5.0	SECUNDA (AI)
3320CC00102	19881025	0730	-2.60	-11.0	CSIR 4253
3320CC00102	19890426	1630	-4.50	-26.0	S4273
3320CC00102	19900608	1120	-4.30	-27.0	H3M11 Kogmans
3320CC00102	19900906	1245	-3.40	-23.0	H3M11 Kogmans
3320CC00102	19900925	1530	-4.70	-32.0	H3M11 Kogmans
3320CC00102	19901206	0810	-1.90	-14.0	H3M11 Kogmans
3320CC00102	19910301	1520	-1.00	-7.0	H3M11 Kogmans

Appendix 14

One factor analyses for
12 chemical ions

One Factor ANOVA X_1 : Source Y_1 : log EC

Analysis of Variance Table

Source:	DF:	Sum Squares:	Mean Square:	F-test:
Between groups	13	117.955	9.073	70.147
Within groups	393	50.834	.129	p = .0001
Total	406	168.789		

Model II estimate of between component variance = .688

Group:	Count:	Mean:	Std. Dev.:	Std. Error:
Bokkeveld	183	2.453	.441	.033
Canal	30	1.454	.278	.051
Dam	2	.651	.069	.048
Enon	4	1.366	.076	.038
Malmesbury	44	1.901	.302	.046
TMS	69	1.214	.3	.036
Witteberg	9	1.792	.119	.04
H1R01Y	4	1.093	.069	.035
H4R04U	3	.634	.056	.032
H4M17	12	1.368	.132	.038
H4M18	11	2.584	.234	.07
H4M19	12	2.442	.146	.042
H5M04	12	1.83	.395	.114
H3M11	12	2.461	.166	.048

F-Test

	H1R01Y	Dam	H4R04U	H4M17	H4M18	H4M19	H5M04	H3M11	Enon	Witteberg	Bokkeveld	TMS	Malmesbury
H1R04Y	.												
Dam	1.56	.											
H4R04U	0.21	0	.										
H4M17	0.14	0.52	0.77	.									
H4M18	3.88	3.76	5.33	5.05	.								
H4M19	3.25	3.27	4.67	4.12	0.07	.							
H5M04	0.97	1.42	2.04	0.76	1.94	1.34	.						
H3M11	3.34	3.34	4.78	4.27	0.05	0	1.42	.					
Enon	0.09	0.41	0.53	0	2.59	2.07	0.38	2.14	.				
Witteberg	0.81	1.27	1.79	0.55	1.85	1.29	0	1.37	0.30	.			
Bokkeveld	4.31	3.82	5.81	7.89	0.11	0	2.60	0	2.75	2.23	.		
TMS	0.03	.037	0.57	0.14	10.60	9.18	2.31	9.47	0.05	1.58	45.78	.	
Malmesbury	1.42	1.79	2.70	1.59	2.44	1.64	0.03	1.76	0.62	0.05	6.43	7.55	.

One Factor ANOVA X_1 : Source Y_1 : log Na

Analysis of Variance Table

Source:	DF:	Sum Squares:	Mean Square:	F-test:
Between groups	13	679.905	52.3	60.017
Within groups	393	342.47	.871	p = .0001
Total	406	1022.375		

Model II estimate of between component variance = 3.956

Group:	Count:	Mean:	Std. Dev.:	Std. Error:
Bokkeveld	183	6.198	1.202	.089
Canal	30	3.908	.517	.094
Dam	2	2.191	.158	.112
Enon	4	3.477	.322	.161
Malmesbury	44	4.566	.757	.114
TMS	69	3.195	.661	.08
Witteberg	9	4.329	.239	.08
H1R01Y	4	2.829	.108	.054
H4R04U	3	2.264	.116	.067
H4M17	12	3.58	.251	.073
H4M18	11	6.47	.546	.165
H4M19	12	6.006	.205	.059
H5M04	12	4.737	1.021	.295
H3M11	12	6.274	.264	.076

F-Test

	H1R01Y	Dam	H4R04U	H4M17	H4M18	H4M19	H5M04	H3M11	Enon	Witteberg	Bokkeveld	TMS	Malmesbury
H1R04Y	.												
Dam	0.05	.											
H4R04U	0.05	0	.										
H4M17	0.15	0.29	0.37	.									
H4M18	3.43	2.74	3.68	4.23	.								
H4M19	2.87	2.20	2.97	3.12	0.11	.							
H5M04	0.96	0.98	1.25	0.71	1.52	0.85	.						
H3M11	3.14	2.52	3.41	3.84	0.02	0.04	1.25	.					
Enon	0.07	0.20	0.22	0	2.32	1.69	0.42	2.67	.				
Witteberg	0.55	0.66	0.85	0.26	2.00	1.28	0.08	1.72	0.18	.			
Bokkeveld	3.92	2.80	4.03	6.81	0.07	0.04	2.12	0.01	2.86	2.65	.		
TMS	0.05	0.17	0.22	0.13	8.99	7.12	2.15	8.56	0.27	0.90	39.89	.	
Malmesbury	0.98	0.95	1.31	0.81	2.82	1.73	0.02	2.43	0.38	0.37	8.34	4.46	.

One Factor ANOVA X_1 : Source Y_1 : log K

Source:	DF:	Sum Squares:	Mean Square:	F-test:
Between groups	13	293.516	22.578	22.026
Within groups	386	395.683	1.025	p = .0001
Total	399	689.198		

Model II estimate of between component variance = 1.658

Group:	Count:	Mean:	Std. Dev.:	Std. Error:
Bokkeveld	182	2.329	1.178	.087
Canal	30	.481	.564	.103
Dam	2	-1.498	1.138	.805
Enon	3	.173	.861	.497
Malmesbury	42	.819	1.211	.187
TMS	66	1.296	.603	.099
Witteberg	9	-.249	.598	.199
H1R01Y	4	-.08	.576	.288
H4R04U	3	-.877	1.236	.714
H4M17	12	.051	.844	.244
H4M18	11	2.426	.514	.155
H4M19	12	1.356	.206	.06
H5M04	12	1.32	1.05	.303
H3M11	12	2.169	.242	.07

F-Test

	H1R01Y	Dam	H4R04U	H4M17	H4M18	H4M19	H5M04	H3M11	Enon	Witteberg	Bokkeveld	TMS	Malmesbury
H1R04Y	-												
Dam	0.20	-											
H4R04U	0.08	0.04	-										
H4M17	0	0.31	0.16	-									
H4M18	1.38	1.98	1.93	2.43	-								
H4M19	0.46	1.05	0.90	0.77	0.49	-							
H5M04	0.44	1.02	0.87	0.72	0.53	0	-						
H3M11	1.14	1.73	1.67	2.02	0.28	0.30	0.33	-					
Enon	0.01	0.25	0.12	0	0.90	0.25	0.24	0.72	-				
Witteberg	0.01	0.19	0.07	0.04	2.98	1.00	0.95	2.28	0.03	-			
Bokkeveld	1.70	2.17	2.28	4.38	0.01	0.80	0.86	0.02	1.03	4.28	-		
TMS	0.54	1.14	1.02	1.18	0.90	0	0	0.58	0.27	1.42	3.87	-	
Malmesbury	0.22	0.77	0.60	0.41	1.69	0.20	0.18	1.28	0.09	0.64	5.84	0.44	-

One Factor ANOVA X_1 ; Source Y_1 : log Ca

Analysis of Variance Table

Source:	DF:	Sum Squares:	Mean Square:	F-test:
Between groups	13	338.164	26.013	48.099
Within groups	393	212.541	.541	p = .0001
Total	406	550.706		

Model II estimate of between component variance = 1.959

Group:	Count:	Mean:	Std. Dev.:	Std. Error:
Bokkeveld	183	3.837	.889	.066
Canal	30	2.477	.423	.077
Dam	2	1.099	0	0
Enon	4	1.628	.463	.232
Malmesbury	44	3.938	.71	.107
TMS	69	1.918	.648	.078
Witteberg	9	3.623	.295	.098
H1R01Y	4	1.941	.118	.059
H4R04U	3	1.099	0	0
H4M17	12	2.319	.343	.099
H4M18	11	4.69	.595	.179
H4M19	12	4.788	.169	.049
H5M04	12	3.044	.767	.221
H3M11	12	4.305	.171	.049

F-Test

	H1R01Y	Dam	H4R04U	H4M17	H4M18	H4M19	H5M04	H3M11	Enon	Witteberg	Bokkeveld	TMS	Malmesbury
H1R04Y	.												
Dam	0.13	-											
H4R04U	0.17	0	-										
H4M17	0.06	0.36	0.51	-									
H4M18	3.15	3.11	4.33	4.59	-								
H4M19	3.48	3.32	4.65	5.20	0.01	-							
H5M04	0.52	0.92	1.29	0.45	2.21	2.60	-						
H3M11	2.36	2.51	3.51	3.37	0.12	0.20	1.36	-					
Enon	0.03	0.05	0.07	0.20	3.91	4.26	0.86	30.6	-				
Witteberg	1.11	1.48	2.04	1.24	0.82	0.99	0.25	0.34	1.57	-			
Bokkeveld	2.00	2.11	3.15	3.68	1.08	1.45	1.00	0.35	2.72	0.07	-		
TMS	0	0.19	0.27	0.23	10.37	11.98	1.83	8.25	0.05	3.28	26.25	-	
Malmesbury	2.08	2.19	3.22	3.51	0.71	0.97	1.07	0.18	2.78	0.11	0.05	15.59	-

One Factor ANOVA X_1 : Source Y_1 : log Mg

Analysis of Variance Table

Source:	DF:	Sum Squares:	Mean Square:	F-test:
Between groups	13	587.816	45.217	55.354
Within groups	393	321.029	.817	p = .0001
Total	406	908.845		

Model II estimate of between component variance = 3.415

Group:	Count:	Mean:	Std. Dev.:	Std. Error:
Bokkeveld	183	4.157	1.162	.086
Canal	30	2.24	.569	.104
Dam	2	0	0	0
Enon	4	1.472	.526	.263
Malmesbury	44	2.927	.752	.113
TMS	69	1.382	.601	.072
Witteberg	9	2.96	.269	.09
H1R01Y	4	1.442	.112	.056
H4R04U	3	.231	.4	.231
H4M17	12	1.979	.328	.095
H4M18	11	4.785	.583	.176
H4M19	12	4.581	.177	.051
H5M04	12	3.062	.95	.274
H3M11	12	4.527	.218	.063

F-Test

	H1R01Y	Dam	H4R04U	H4M17	H4M18	H4M19	H5M04	H3M11	Enon	Witteberg	Bokkeveld	TMS	Malmesbury
H1R04Y	-												
Dam	0.26	-											
H4R04U	0.24	0.01	-										
H4M17	0.08	0.63	0.69	-									
H4M18	3.09	3.65	4.60	4.26	-								
H4M19	2.78	3.39	4.20	3.83	0.02	-							
H5M04	0.74	1.51	1.81	0.66	1.81	1.31	-						
H3M11	2.69	3.31	4.17	3.61	0.04	0	1.21	-					
Enon	0	0.27	0.25	0.07	3.03	2.73	0.71	2.64	-				
Witteberg	0.61	1.35	1.58	0.47	1.55	1.27	0.01	1.19	0.58	-			
Bokkeveld	2.72	3.22	4.26	5.03	0.39	0.19	1.72	0.15	2.66	1.56	-		
TMS	0	0.35	0.36	.034	10.35	9.85	2.72	9.53	0	1.97	36.34	-	
Malmesbury	0.76	1.54	1.92	0.80	2.86	2.43	0.02	2.27	0.73	0	5.06	6.04	-

One Factor ANOVA X_1 : Source Y_1 : log M Alk

Analysis of Variance Table

Source:	DF:	Sum Squares:	Mean Square:	F-test:
Between groups	13	418.229	32.171	56.663
Within groups	390	221.429	.568	p = .0001
Total	403	639.658		

Model II estimate of between component variance = 2.431

Group:	Count:	Mean:	Std. Dev.:	Std. Error:
Bokkeveld	183	5.095	.813	.06
Canal	30	3.281	.628	.115
Dam	2	1.589	.287	.203
Enon	4	2.846	.562	.281
Malmesbury	44	5.043	.602	.091
TMS	67	2.908	.93	.114
Witteberg	9	4.764	.362	.121
H1R01Y	4	2.731	.34	.17
H4R04U	3	1.67	.105	.061
H4M17	12	3.077	.312	.09
H4M18	11	5.658	.553	.167
H4M19	11	5.342	.171	.052
H5M04	12	4.135	.932	.269
H3M11	12	5.577	.189	.055

F-Test

	H1R01Y	Dam	H4R04U	H4M17	H4M18	H4M19	H5M04	H3M11	Enon	Witteberg	Bokkeveld	TMS	Malmesbury
H1R04Y	-	-	-	-	-	-	-	-	-	-	-	-	-
Dam	0.24	-	-	-	-	-	-	-	-	-	-	-	-
H4R04U	0.26	0	-	-	-	-	-	-	-	-	-	-	-
H4M17	0.05	0.52	0.64	-	-	-	-	-	-	-	-	-	-
H4M18	3.41	3.80	5.08	5.18	-	-	-	-	-	-	-	-	-
H4M19	2.71	3.29	4.31	3.99	0.07	-	-	-	-	-	-	-	-
H5M04	0.80	1.51	1.98	0.91	1.80	1.13	-	-	-	-	-	-	-
H3M11	3.29	3.69	4.96	5.08	0.01	0.04	1.69	-	-	-	-	-	-
Enon	0	0.29	0.32	0.02	3.14	2.48	0.68	3.03	-	-	-	-	-
Witteberg	1.55	2.23	2.92	1.98	0.54	0.22	0.28	0.48	1.38	-	-	-	-
Bokkeveld	2.96	3.29	4.69	6.21	0.45	0.09	1.41	0.36	2.68	0.13	-	-	-
TMS	0.02	0.46	0.60	0.04	9.66	7.58	9.62	2.07	0	3.70	31.77	-	-
Malmesbury	2.66	3.09	4.33	4.94	0.45	0.11	1.05	0.36	2.40	0.08	0.01	16.40	-

One Factor ANOVA X_1 : Source Y_1 : log CI

Analysis of Variance Table

Source:	DF:	Sum Squares:	Mean Square:	F-test:
Between groups	13	726.44	55.88	54.697
Within groups	393	401.498	1.022	p = .0001
Total	406	1127.938		

Model II estimate of between component variance = 4.22

Group:	Count:	Mean:	Std. Dev.:	Std. Error:
Bokkeveld	183	6.672	1.277	.094
Canal	30	4.265	.6	.11
Dam	2	2.481	.118	.084
Enon	4	4.212	.206	.103
Malmesbury	44	4.993	.845	.127
TMS	69	3.584	.817	.098
Witteberg	9	4.724	.352	.117
H1R01Y	4	3.348	.166	.083
H4R04U	3	2.559	.129	.074
H4M17	12	4.014	.274	.079
H4M18	11	7.032	.577	.174
H4M19	12	6.711	.191	.055
H5M04	12	5.218	1.03	.297
H3M11	12	6.785	.27	.078

F-Test

	H1R01Y	Dam	H4R04U	H4M17	H4M18	H4M19	H5M04	H3M11	Enon	Witteberg	Bokkeveld	TMS	Malmesbury
H1R04Y	-												
Dam	0.08	-											
H4R04U	0.08	0	-										
H4M17	0.10	0.30	0.38	-									
H4M18	3.00	2.64	3.55	3.94	-								
H4M19	2.56	2.31	3.12	3.29	0.04	-							
H5M04	0.79	0.97	1.28	0.66	1.42	1.01	-						
H3M11	2.67	2.39	3.23	3.47	0.03	0	1.11	-					
Enon	0.11	0.30	0.35	0.01	1.76	1.41	0.23	1.50	-				
Witteberg	0.40	0.62	0.79	0.20	1.99	1.53	0.10	1.65	0.06	-			
Bokkeveld	3.26	2.62	3.76	6.99	0.10	0	1.79	0.01	1.76	2.45	-		
TMS	0.02	0.18	0.23	0.14	8.49	7.53	2.05	7.88	0.11	0.78	35.96	-	
Malmesbury	0.75	0.91	1.25	0.68	2.75	2.10	0.04	2.28	0.17	0.04	7.52	4.02	-

One Factor ANOVA X_1 ; Source Y_1 : log SO4

Analysis of Variance Table

Source:	DF:	Sum Squares:	Mean Square:	F-test:
Between groups	13	480.223	36.94	33.808
Within groups	391	427.225	1.093	p = .0001
Total	404	907.448		

Model II estimate of between component variance = 2.758

Group:	Count:	Mean:	Std. Dev.:	Std. Error:
Bokkeveld	183	4.797	1.343	.099
Canal	30	3.323	.594	.108
Dam	2	1.099	0	0
Enon	4	2.013	.077	.039
Malmesbury	44	3.975	.828	.125
TMS	67	2.293	.83	.101
Witteberg	9	3.999	.148	.049
H1R01Y	4	2.223	.291	.145
H4R04U	3	1.461	.129	.074
H4M17	12	3.235	.259	.075
H4M18	11	5.71	.507	.153
H4M19	12	5.482	.217	.063
H5M04	12	4.107	.879	.254
H3M11	12	5.489	.258	.075

F-Test

	H1R01Y	Dam	H4R04U	H4M17	H4M18	H4M19	H5M04	H3M11	Enon	Witteberg	Bokkeveld	TMS	Malmesbury
H1R04Y	-												
Dam	0.12	-											
H4R04U	0.07	0.01	-										
H4M17	0.22	0.55	0.53	-									
H4M18	2.57	2.53	3.00	2.48	-								
H4M19	2.24	2.32	2.73	2.13	0.02	-							
H5M04	0.75	1.09	1.18	0.32	1.04	0.80	-						
H3M11	2.25	2.33	2.74	2.15	0.02	0	0.81	-					
Enon	0.01	0.78	0.04	0.32	2.83	2.54	0.93	2.58	-				
Witteberg	0.62	0.97	1.02	0.21	1.02	0.80	0	0.80	0.77	-			
Bokkeveld	1.83	1.90	2.31	1.93	0.61	0.37	0.38	0.38	2.14	0.38	-		
TMS	0	0.20	0.14	0.64	7.77	7.29	2.36	7.32	0.02	1.63	21.65	-	
Malmesbury	0.79	1.12	1.25	0.36	1.88	1.51	0.01	1.52	0.99	0	1.69	5.23	-

One Factor ANOVA X_1 : Source Y_1 : log F

Analysis of Variance Table

Source:	DF:	Sum Squares:	Mean Square:	F-test:
Between groups	13	173.087	13.314	19.486
Within groups	384	262.375	.683	p = .0001
Total	397	435.463		

Model II estimate of between component variance = .972

Group:	Count:	Mean:	Std. Dev.:	Std. Error:
Bokkeveld	182	.214	1.008	.075
Canal	28	-1.478	.539	.102
Dam	2	-1.753	.777	.549
Eron	4	-1.06	.166	.083
Malmesbury	44	-.717	.642	.097
TMS	67	-.995	.652	.08
Witteberg	9	-1.083	.192	.064
H1R01Y	4	-1.335	.789	.394
H4R04U	3	-.751	.427	.246
H4M17	9	-1.104	.52	.173
H4M18	11	.482	.768	.232
H4M19	12	.392	.632	.182
H5M04	11	-.873	.785	.237
H3M11	12	.485	.51	.147

F-Test

	H1R01Y	Dam	H4R04U	H4M17	H4M18	H4M19	H5M04	H3M11	Eron	Witteberg	Bokkeveld	TMS	Malmesbury
H1R04Y	-												
Dam	0.03	-											
H4R04U	0.07	0.14	-										
H4M17	0.02	0.08	0.03	-									
H4M18	0.09	0.90	0.40	1.40	-								
H4M19	1.01	0.89	0.35	1.30	0.01	-							
H5M04	0.07	0.15	0	0.03	1.14	1.04	-						
H3M11	1.12	0.97	0.41	1.46	0	0.01	1.19	-					
Eron	0.02	0.07	0.02	0	0.79	0.71	0.01	0.81	-				
Witteberg	0.02	0.08	0.03	0	1.37	1.26	0.03	1.43	0	-			
Bokkeveld	1.06	0.86	0.31	1.68	0.08	0.04	1.38	0.93	0.72	1.63	-		
TMS	0.05	0.13	0.02	0.01	2.32	2.21	0.02	2.51	0	0.01	8.07	-	
Malmesbury	0.16	0.23	0	0.13	1.43	1.31	0.02	1.54	0.05	0.11	3.48	0.23	-

One Factor ANOVA X_1 : Source Y_1 : log B

Analysis of Variance Table

Source:	DF:	Sum Squares:	Mean Square:	F-test:
Between groups	13	627.558	48.274	33.921
Within groups	392	557.86	1.423	p = .0001
Total	405	1185.418		

Model II estimate of between component variance = 3.604

Group:	Count:	Mean:	Std. Dev.:	Std. Error:
Bokkeveld	183	-1.286	1.529	.113
Canal	30	-3.268	.793	.145
Dam	2	-4.343	0	0
Enon	4	-4.343	0	0
Malmesbury	44	-3.348	.864	.13
TMS	68	-4.271	.256	.031
Witteberg	9	-3.167	.752	.251
H1R01Y	4	-4.343	0	0
H4R04U	3	-4.343	0	0
H4M17	12	-3.023	1.066	.308
H4M18	11	-1.152	1.183	.357
H4M19	12	-1.741	1.381	.399
H5M04	12	-1.971	1.093	.316
H3M11	12	-1.212	1.06	.306

F-Test

	H1R01Y	Dam	H4R04U	H4M17	H4M18	H4M19	H5M04	H3M11	Enon	Witteberg	Bokkeveld	TMS	Malmesbury
H1R04Y	.												
Dam	0	.											
H4R04U	0	0	.										
H4M17	0.28	0.16	0.23	.									
H4M18	1.61	0.93	1.30	1.09	.								
H4M19	1.10	0.63	0.88	0.53	0.11	.							
H5M04	0.91	0.52	0.73	0.36	0.21	0.02	.						
H3M11	1.59	0.91	1.27	1.06	0	0.09	0.19	.					
Enon	0	0	0	0.28	1.61	1.10	0.91	1.59	.				
Witteberg	0.21	0.12	0.17	0.01	1.09	0.57	0.40	1.06	0.21	.			
Bokkeveld	1.98	1.00	1.49	1.84	0.01	0.13	0.29	0	1.98	1.64	.		
TMS	0	0	0	0.86	4.98	3.53	2.92	5.16	0	0.52	23.88	.	
Malmesbury	0.20	1.00	0.15	0.05	2.29	1.32	0.97	2.33	0.20	0.01	6.15	1.23	.

One Factor ANOVA X_1 : Source Y_1 : log Br

Analysis of Variance Table

Source:	DF:	Sum Squares:	Mean Square:	F-test:
Between groups	13	506.704	38.977	29.552
Within groups	345	455.032	1.319	p = .0001
Total	358	961.736		

Model II estimate of between component variance = 2.897

Group:	Count:	Mean:	Std. Dev.:	Std. Error:
Bokkeveld	175	.869	1.307	.099
Canal	24	-1.557	.785	.16
Dam	1	-3.507	*	*
Enon	3	-1.333	.319	.184
Malmesbury	40	-.922	.938	.148
TMS	46	-2.03	.923	.136
Witteberg	9	-1.162	.775	.258
H1R01Y	3	-2.504	.409	.236
H4R04U	1	-3.219	*	*
H4M17	10	-1.293	1.079	.341
H4M18	11	.806	1.053	.317
H4M19	12	.702	.915	.264
H5M04	12	-.318	1.627	.47
H3M11	12	.722	.727	.21

F-Test

	H1R01Y	Dam	H4R04U	H4M17	H4M18	H4M19	H5M04	H3M11	Enon	Witteberg	Bokkeveld	TMS	Malmesbury
H1R04Y	.												
Dam	0.04	.											
H4R04U	0.02	0	.										
H4M17	0.20	0.26	0.20	.									
H4M18	1.51	0.99	0.87	1.35	.								
H4M19	1.44	0.95	0.83	1.27	0	.							
H5M04	0.67	0.55	0.45	0.30	0.42	0.36	.						
H3M11	1.46	0.96	0.84	1.29	0	0	0.38	.					
Enon	0.12	0.21	0.16	0	0.63	0.58	0.14	0.59	.				
Witteberg	0.24	0.29	0.22	0.01	1.12	1.04	0.21	1.06	0	.			
Bokkeveld	1.96	1.11	0.97	2.58	0	0.02	0.92	0.01	0.83	2.06	.		
TMS	0.04	0.12	0.08	0.26	4.16	4.14	4.20	1.63	0.08	0.33	17.66	.	
Malmesbury	0.41	0.38	0.30	0.06	1.50	1.42	0.20	1.46	0.03	0.03	6.09	1.53	.

One Factor ANOVA X_1 : Source Y_1 : log Sr

Analysis of Variance Table

Source:	DF:	Sum Squares:	Mean Square:	F-test:
Between groups	13	421.932	32.456	32.037
Within groups	393	398.15	1.013	p = .0001
Total	406	820.082		

Model II estimate of between component variance = 2.419

Group:	Count:	Mean:	Std. Dev.:	Std. Error:
Bokkeveld	183	-.571	1.071	.079
Canal	30	-2.131	.591	.108
Dam	2	-3.7	.909	.643
Enon	4	-2.725	1.336	.668
Malmesbury	44	-.64	.935	.141
TMS	69	-2.903	1.133	.136
Witteberg	9	-.981	.607	.202
H1R01Y	4	-3.269	.337	.169
H4R04U	3	-3.402	1.066	.615
H4M17	12	-2.029	1.097	.317
H4M18	11	.104	.858	.259
H4M19	12	-.049	.832	.24
H5M04	12	-.935	1.036	.299
H3M11	12	-.203	.505	.146

F-Test

	H1R01Y	Dam	H4R04U	H4M17	H4M18	H4M19	H5M04	H3M11	Enon	Witteberg	Bokkeveld	TMS	Malmesbury
H1R04Y	.												
Dam	0.02	.											
H4R04U	0	0.01	.										
H4M17	0.35	0.36	0.34	.									
H4M18	2.53	1.66	2.20	1.98	.								
H4M19	2.36	1.74	2.06	1.79	0.01	.							
H5M04	1.24	1.00	1.11	0.55	0.47	0.36	.						
H3M11	2.14	1.59	1.87	1.52	0.04	0.01	0.24	.					
Enon	0.05	0.10	0.06	0.11	1.78	1.63	0.73	1.45	.				
Witteberg	1.10	0.92	1.00	0.43	0.44	0.34	0	0.24	0.64	.			
Bokkeveld	2.17	1.47	1.80	1.82	0.36	0.23	0.11	0.12	1.38	0.11	.		
TMS	0.04	0.09	0.05	0.59	6.51	6.32	3.01	5.68	0.01	2.23	20.70	.	
Malmesbury	1.92	1.36	1.63	1.38	0.37	0.25	0.06	0.14	1.21	0.07	0.01	10.45	.

Appendix 15

One factor analyses for
 ^2H and ^{18}O

One Factor ANOVA X_1 : Source Y_1 : O-18

Analysis of Variance Table

Source:	DF:	Sum Squares:	Mean Square:	F-test:
Between groups	13	368.179	28.321	25.913
Within groups	225	245.908	1.093	p = .0001
Total	238	614.086		

Model II estimate of between component variance = 2.095

Group:	Count:	Mean:	Std. Dev.:	Std. Error:
Bokkeveld	55	-5.096	1.044	.141
Canal	2	-5.25	.778	.55
Dam	2	.65	1.202	.85
Enon	4	-5.25	.603	.301
Malmesbury	56	-5.287	.924	.123
TMS	71	-6.31	.793	.094
Witteberg	9	-4.644	.388	.129
H1R01Y	3	-2.333	3.496	2.019
H4R04U	4	-1.125	.737	.368
H4M17	6	-3.383	1.903	.777
H4M18	7	-2.829	.734	.278
H4M19	7	-3.543	1.061	.401
H5M04	5	-3.42	2.411	1.078
H3M11	8	-3.4	1.43	.506

F-Test

	H1R01Y	Dam	H4R04U	H4M17	H4M18	H4M19	H5M04	H3M11	Enon	Witteberg	Bokkeveld	TMS	Malmesbury
H1R04Y	-												
Dam	0.75	-											
H4R04U	0.18	0.30	-										
H4M17	0.16	1.72	0.86	-									
H4M18	0.04	1.33	0.52	0.07	-								
H4M19	0.22	1.93	1.05	0.01	0.13	-							
H5M04	0.16	1.67	0.82	0	0.07	0	-						
H3M11	0.18	1.85	0.97	0	0.09	0.01	0	-					
Enon	1.03	3.27	2.40	0.59	1.05	0.52	0.52	0.64	-				
Witteberg	0.85	3.23	2.41	0.40	0.91	0.34	0.34	0.48	0.07	-			
Bokkeveld	1.52	4.46	4.14	1.12	2.25	1.06	0.91	1.42	0.01	0.11	-		
TMS	3.20	6.63	7.17	3.34	5.44	3.43	2.78	4.29	0.30	1.56	3.21	-	
Malmesbury	1.75	4.79	4.58	1.38	2.65	1.33	1.13	1.78	0	0.23	0.07	2.30	-

Appendix 16

Description of Piper-, Durov-, Schoeller, SAR-
and Expanded Durov Diagrams

PIPER DIAGRAM

The chemical composition of ground water reflects the processes which are responsible for the different constituents it contains: Wind blowing over the ocean carries mainly sodium chloride landwards. Oxygen, nitrogen and carbon dioxide dissolve when the humidity in the air condenses. Additional carbon dioxide and humic acids dissolve when water percolates through the soil containing organic matter.

The ground water changes its composition as the water moves through the aquifer. Minerals dissolve and release salts; sulphides may oxidize; cations are exchanged; sulphides and nitrates can be reduced through bacterial action; evaporation leads to concentration; and once the solubility products are exceeded minerals are precipitated. Mixing with water of different origin also influences the composition.

Trilinear diagrams are used for the investigation of ions or groups of ions as a function of the concentration. On these diagrams the milli-equivalent percentages of the major cations and anions are plotted; and it has been found that the point at which an analysis plots is of considerable diagnostical value.

The Piper diagram is a combination of two trilinear diagrams and a central diamond field. In the diamond field the cations Ca^{2+} , Mg^{2+} , $\text{Na}^{+} + \text{K}^{+}$; and the anions SO_4^{2-} , Cl^{-} and $\text{HCO}_3^{-} + \text{CO}_3^{2-}$ are represented by a point, in the trilinear diagrams cations and anions each separately.

To convert the units mg/L normally given in an analysis to milli-equivalents the determined quantities must be divided by the molecular weight of the respective ion and

its valence. The constants for the conversion of the different ions are:

Cations		Anions	
Ca	1/20	HCO_3	1/61
Mg	1/12	CO_3	1/30
Na	1/23	Cl	1/35.5
K	1/39	NO_3	1/62
		SO_4	1/48

The percentage milli-equivalents for the different cations are calculated by dividing the respective milli-equivalent values by the sum of the milli-equivalents of the cations. The percentage milli-equivalents for the anions are calculated accordingly.

After the cations and anions are plotted in the trilinear diagrams their position is projected to the diamond field. Based on the position in the central diamond field ground water can be divided into four categories, i.e.

- Recently recharged ground water rich in calcium and/or magnesium and bicarbonate.
- A dynamic regime with water rich in bicarbonate with increasing sodium (and potassium) concentrations.
- "Stagnant" or relatively old ground water at the end of the cycle with high sodium, chloride and/or sulphate values. It plots near the point for sea water.
- Calcium sulphate water as well as other relatively seldom encountered water which plot in the upper half of the diamond field.

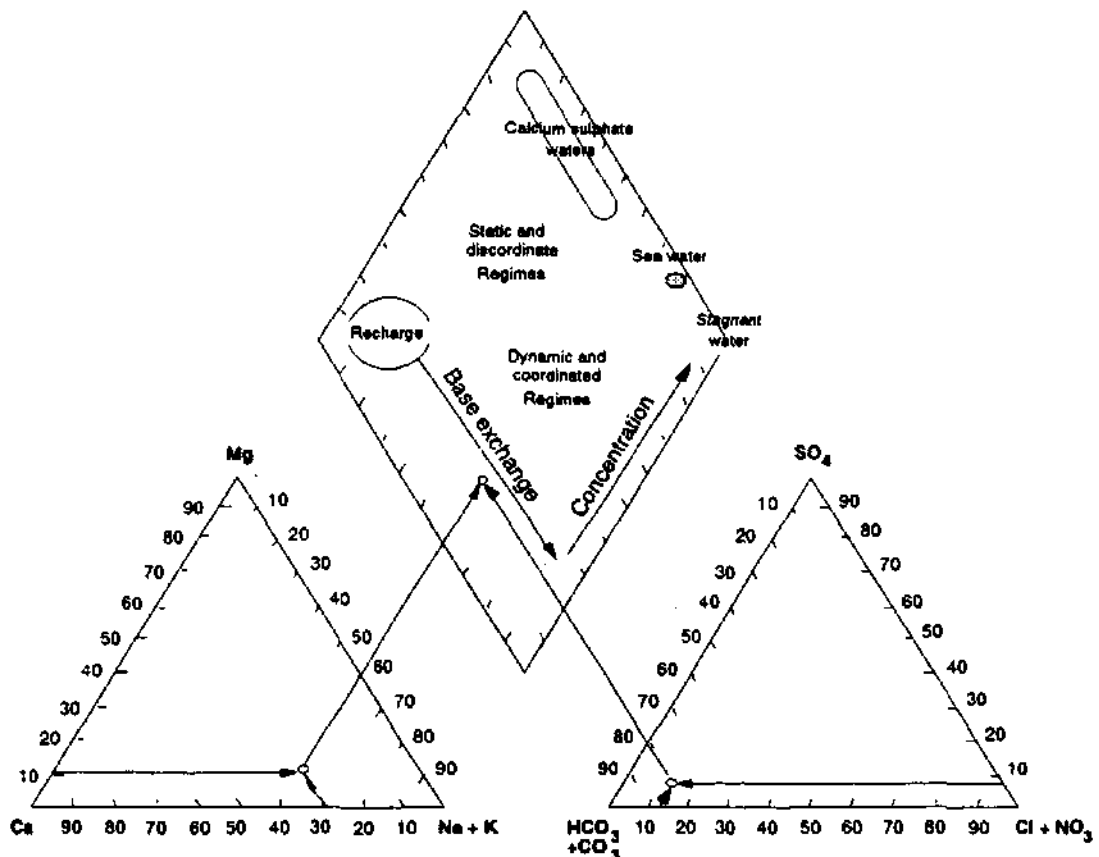

After A.M. Piper: A graphic procedure in the geochemical interpretation of water analysis.- Trans. Am. Geophys. Union, 25: 914 - 928. Washington, 1944.

SCHOELLER DIAGRAM

The Schoeller diagram consists of a number of vertical axes on which the concentrations in mg/l of various cations and anions are plotted. The axes are displaced vertically so that the concentrations can also be read in milliequivalents on the two outer scales. Points for the individual ions of each analysis are connected by straight lines. Additional axes for other variables may be added to the diagram.

The diagram displays the ion ratios between points joined by straight lines. Identical ion ratios with different concentrations plot as parallel lines. Similar waters can thus be identified. The diagram also allows the classification of samples. Shown are a sodium-sulphate and a sodium-chloride water. Only a limited number of analyses can be shown before the diagram becomes crowded.

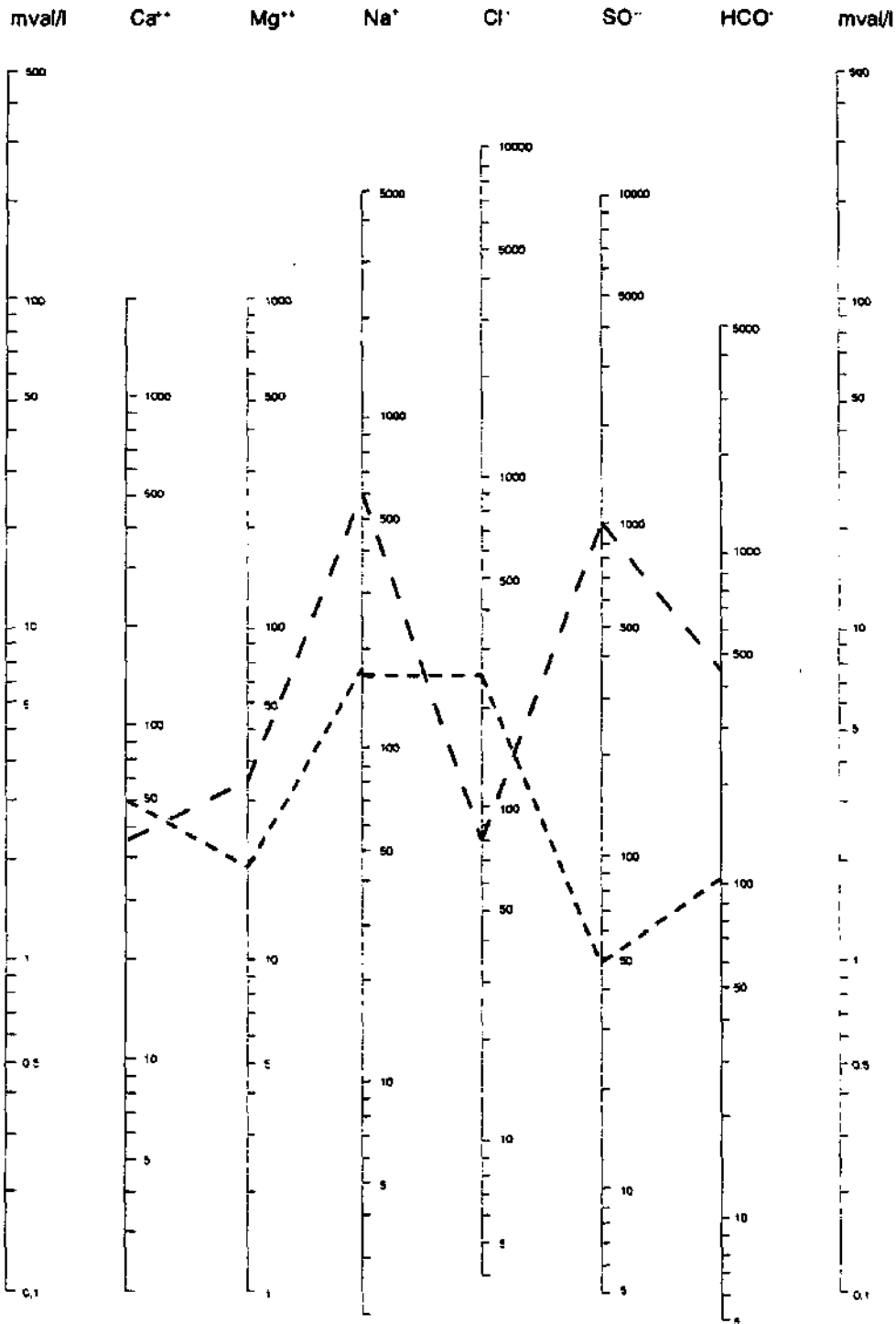

SODIUM ADSORPTION DIAGRAM

CLASSIFICATION OF WATER FOR IRRIGATION

The electrical conductivity, EC, of water is a measure of the total ions present in solution. Therefore a measure of total salt content of water. Since Na⁺ contributes to the total salt content of water, EC measurements will reflect its presence in solutions. High salt contents and high alkalinity in soils are detrimental to plant growth. The following classes of water can be distinguished by means of the Sodium Adsorption Ratio Diagram:

C1-S1 Low salinity-low sodium water: Waters in this class can be used with relative safety for irrigating any crop. It may be necessary to leach soils of low permeability occasionally if salt-sensitive plants are to be grown. There is little danger of developing harmful levels of exchangeable sodium from the use of waters of this class.

C1-S2 Low salinity-medium sodium water: Waters of this class can be used for irrigation if the salt which accumulates, through evaporation of water and water lost by transpiration, is leached from the root-zone. This should normally occur during irrigation. If these waters are used on soils having high base exchange capacity dominated by sodium, the slow water penetration problem will be alleviated by the use of gypsum and the salts may then be leached from the soil quite readily.

C1-S3 Low salinity-high sodium water: Ordinarily there is a tendency for soil which is irrigated with waters of this class to disperse, because of the high level of exchangeable sodium and thus reduce the rate of penetration of water into the soil. Treatment of such soils will consist of providing good drainage, the addition of soil amendments and organic matter and the application of adequate water for leaching.

C1-S4 Low salinity-very high sodium water: Waters falling into this class may be considered likely to cause penetration problems on medium to fine-textured soils. Calcium from highly calcareous soils or from soils with gypsum present, may reduce the sodium hazard. If not naturally present, gypsum may be added. Organic matter should be used, if available.

C2-S1 Medium salinity-low sodium water: Waters in this class may be used if a moderate amount of leaching occurs. Plants with moderate salt tolerance can be grown in most cases without special practices of salinity control. Very little danger exists from the development of harmful levels of exchangeable sodium, but some sodium-sensitive crops such as stone-fruit trees and avocados may accumulate injurious levels of sodium.

C2-S2 Medium salinity-medium sodium water: These waters will present a sodium hazard when used on fine-textured soils having a high base-exchange capacity. Gypsum should be applied, followed by moderate leaching. On coarse-textured or organic soils of good permeability, this water may be used without special caution.

C2-S3 Medium salinity-high sodium water: This water, being high in sodium, will produce harmful amounts of exchangeable sodium in the soil, requiring special soil management if crops are to be produced successfully. These practices include adequate drainage, high leaching and organic matter additions. If the soil is not well-supplied with gypsum, this amendment should

be added to either the soil or the water. Chemical amendments may bring about the required condition in the soil, but their use may not be feasible for low monetary value crops.

C2-S4 Medium salinity-very high sodium water: Very high sodium waters are seldom used for irrigation, except in the low and medium salinity classes. Unless calcium is available in the soil, it must be added. Good soil drainage is essential if waters in this class are to be used for irrigation. Waters in this class could not be used successfully, except on very permeable soils or on those well-supplied with calcium. If these conditions are not present, amendments may be used to supply the necessary calcium.

C3-S1 High salinity - low sodium water: This water should only be used on soils which can be leached easily. Salinity control must be practiced at all times. Only salt tolerant plants should be grown.

C3-S2 High salinity - medium sodium water: This water should be used only on those soils which have good drainage. Gypsum should be added to the soil or water, if it is not already present in the soil, to facilitate leaching. Only plants having a good salt tolerance should be grown.

C3-S3 High salinity - high sodium water: This water should be used only on soils having unrestricted drainage where special management for salinity control may be practiced. Because of the marginal nature of this water, special practices should include good drainage, frequent leaching and organic matter additions. Gypsiferous soils may not be adversely affected by the use of water of this quality, but others may develop harmful levels of exchangeable sodium. The cost of chemical amendments could be prohibitive in extreme conditions.

C3-S4 High salinity - very high sodium water: Because of the high salt content of this water, it should be used only on soils having unrestricted drainage, for use by crops with good salt tolerance. Unfortunately, amendments may not be practical with waters of very high salinity.

C4-S1 Very high salinity - low sodium water: This water is generally considered to be poor quality for irrigation, but it may be used if all other conditions are favourable. Specifically, drainage must be adequate, additional water must be applied for leaching and only crops of the highest salt tolerance used. There is little likelihood that this class of water will create an exchangeable sodium problem

C4-S2 Very high salinity - medium sodium water: The very high salinity of this water permits occasional use and only then under favourable soil and

plant conditions. An exchangeable sodium problem might develop in a soil irrigated with this water, if the soil is fine-textured or otherwise poorly drained. Gypsum will reduce the sodium hazard. Only plants of high salt tolerance should be grown if water of this quality must be used.

C4-S3 Very high salinity - high sodium water: Because of the excessively high salt content of this water, it is not recommended for use except under very special conditions. If used at all, the soil must be permeable and well-drained. Water must be applied in considerable excess to provide for leaching, and only the most salt tolerant crops should be used. With respect to the high sodium content, this water will contribute to the

development of unfavourable conditions in the soil which, in turn, will require the standard treatment for the prevention and cure of high-sodium soil conditions.

C4-S4 Very high salinity - very high sodium water: This water is undesirable for irrigation with respect to both salinity and alkalinity. If used at all, it should be used very freely to leach the salt from the soil. Calcium from any source, whether dissolved from the soil or applied as an amendment, may improve the water to the point where it may have limited use, thus calcium amendments may improve conditions where waters belonging in classes C1-S3 and C1-S4 may have provisional use as irrigation waters.

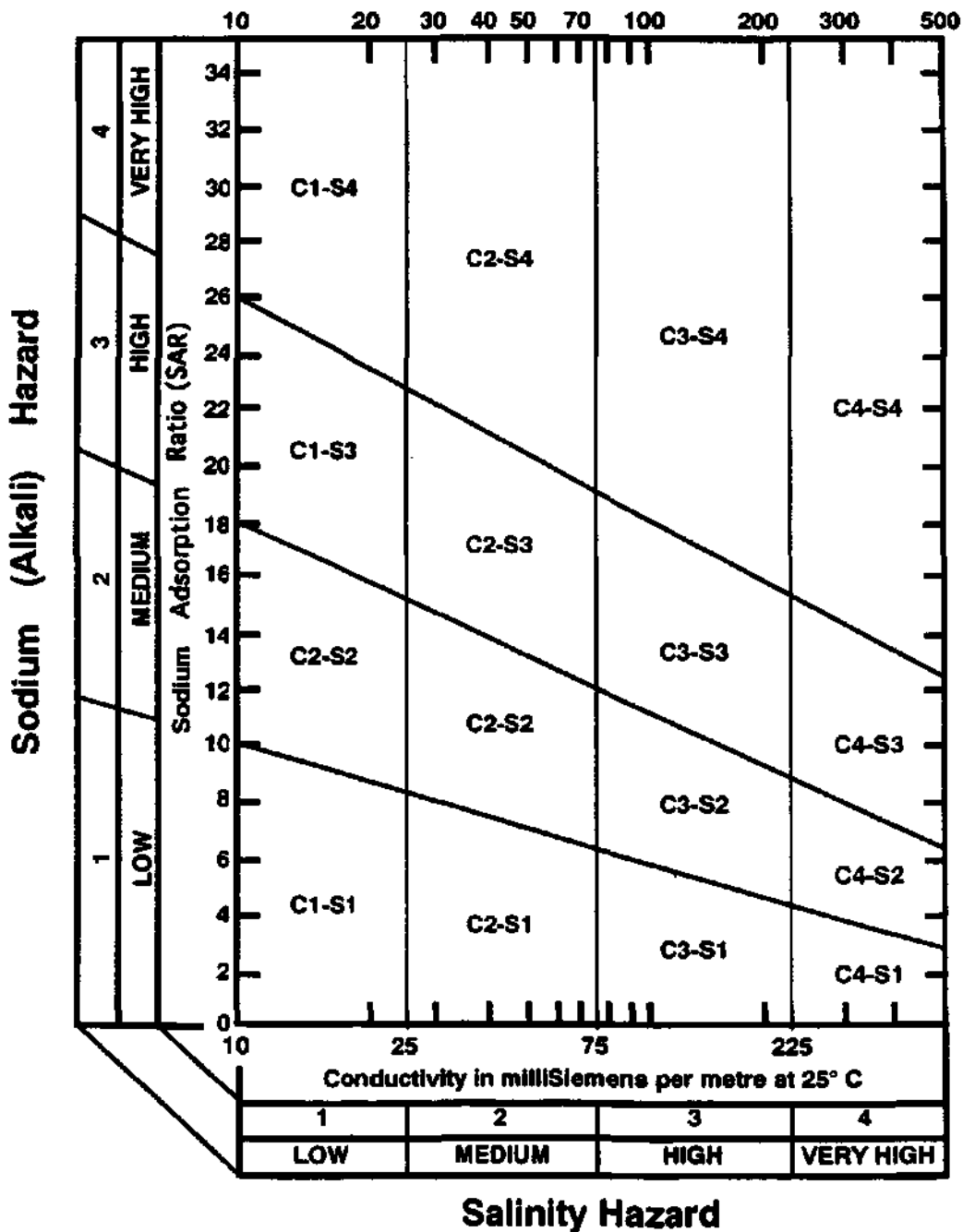

After United States, Department of Agriculture: Diagnosis and improvement of saline and alkaline soils. Agriculture Handbook 60, Washington 1954.

DUROV DIAGRAM

The percentage milli-equivalents of the major cations and anions are plotted in trilinear diagrams. Cations and anions together total 100 %. Similar to the Piper Diagram the positions in the trilinear diagrams are

projected to the central square. Additional variables, e.g. the concentration, conductivity or any other constituent may be plotted in one or more rectangles to the right or the bottom of the central square.

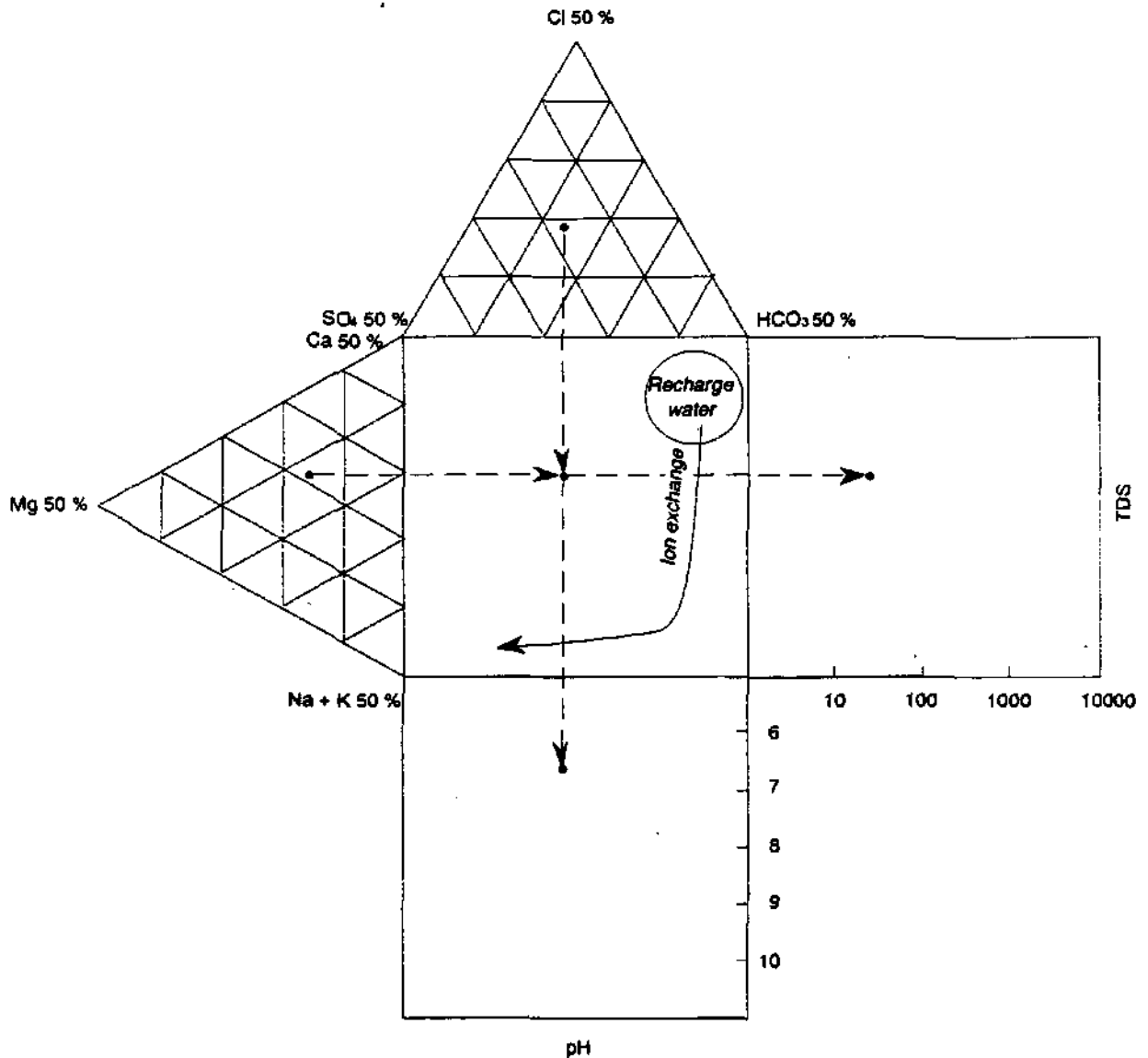

After J.W. Lloyd & J.A. Heathcote: Natural inorganic chemistry in relation to groundwater.- Clarendon Press, Oxford, 1985. Original publication: S.A. Durov (1948): Natural waters and graphic representation of their composition. Dokl. Akad. Nauk SSSR, 59, p. 87 - 90.

EXPANDED DUROV DIAGRAM

Like the Piper and Durov Diagrams the Expanded Durov Diagram is based on the percentage of the major ion milliequivalent values. As in the Durov Diagram cations and anions total 100 per cent and further variables can also be displayed.

The significance of the nine fields of the expanded Durov diagram is as follows:

1. HCO_3^- and Ca^{2+} are dominant, frequently indicating recharging water.
2. HCO_3^- and Mg^{2+} are dominant, indicating water associated with dolomite or partial ion exchange.
3. HCO_3^- and Na^+ are dominant, normally indicating ion exchanged waters.
4. SO_4^{2-} and Ca^{2+} are dominant. Recharge water in lavas or gypsiferous deposits or indicating mixing or dissolution.
5. No dominant ions. Indicating dissolution or mixing.
6. SO_4^{2-} and Na^+ are dominant. Seldom encountered, probable mixing influences.
7. Cl^- and Ca^{2+} are dominant. Seldom encountered. Possible causes: cement pollution or reverse ion exchange.
8. Cl^- dominant water may be related to reverse ion exchange.
9. Cl^- and Na^+ are dominant indicating end-point waters.

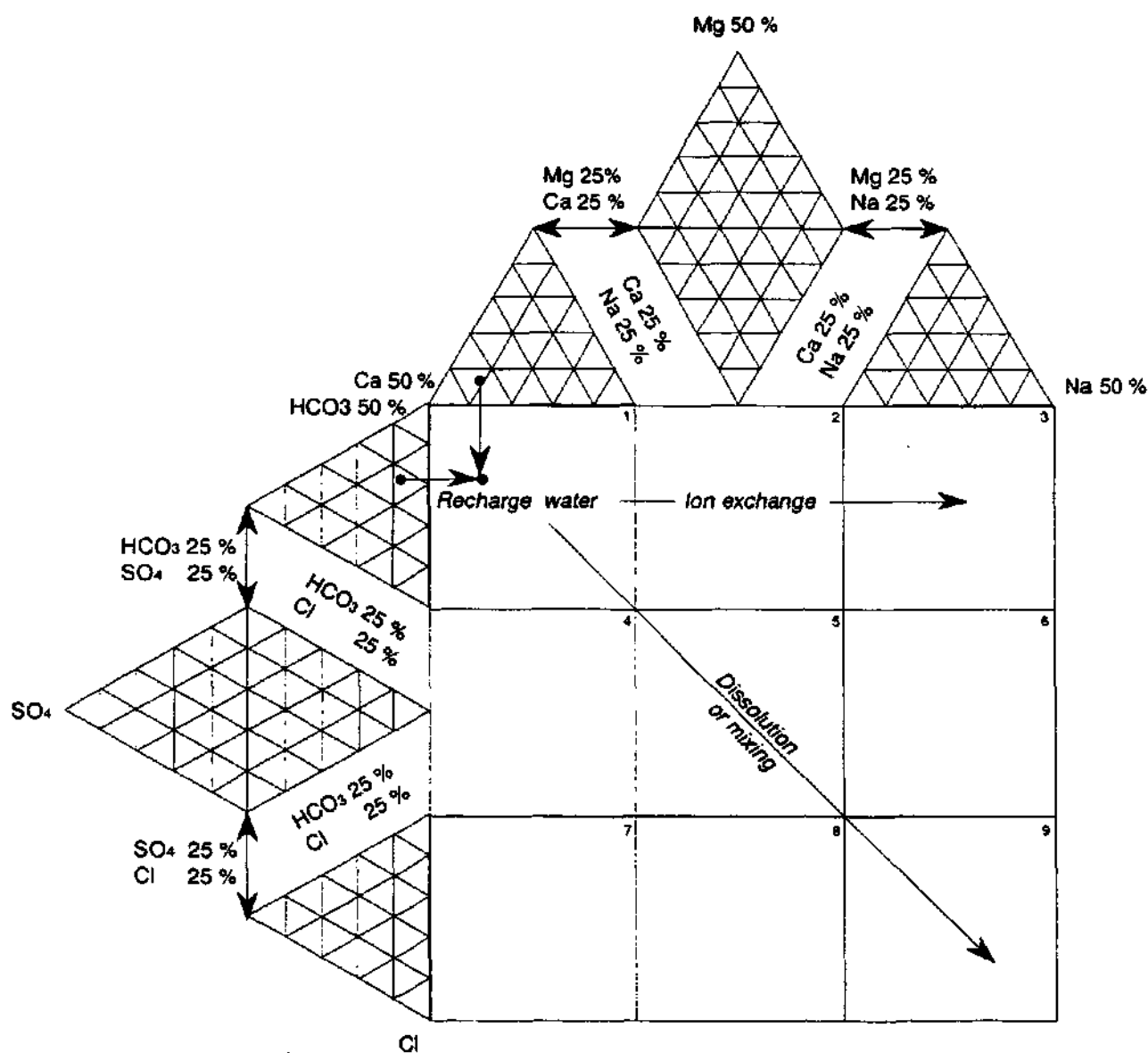

After J.W. Lloyd & J.A. Heathcote: Natural inorganic chemistry in relation to groundwater.- Clarendon Press, Oxford, 1985. See also D.J. Burdon & S. Mazloum: Some chemical properties of groundwater from Syria. UNESCO Symp. Teheran, pp. 73-90. Unesco, Paris 1961.